

**The University of Asia Pacific**  
**Department of Civil Engineering**  
**Final Examination Fall 2009 (Set A)**  
**Program: B.Sc. Engineering (Civil)**

Course Title: Engineering Mechanics I  
 Time: 3 Hours

Course Code: CE 101  
 Full Marks: 100 (=10 × 10)

[Answer any 10 (ten) of the following 14 questions]

1. In the following figure, calculate the weight of the block A and tension in the cable (T) to keep cable PQ horizontal.

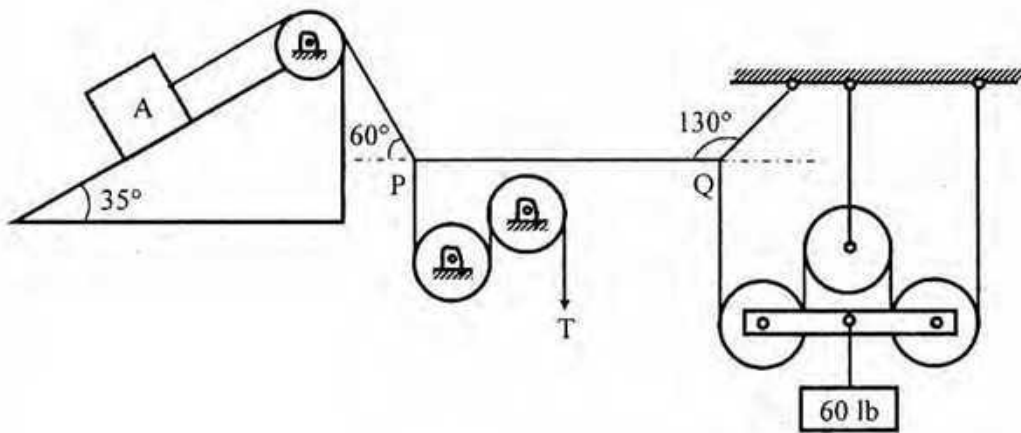

2. In the beam system shown below, calculate the reactions at supports B, F and H and also calculate the axial force, shear force and bending moment at C.

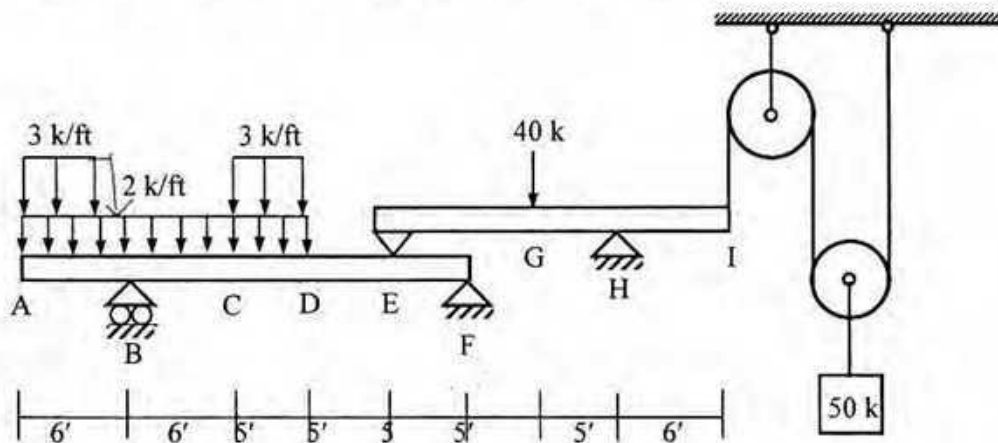

3. For the force system shown below, the resultant (R) acts horizontally. Calculate-
- the magnitude of N
  - the magnitude and location of R.

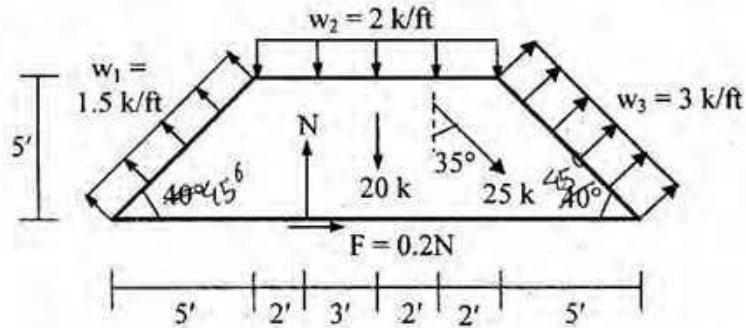

4. In the figure of question 3, if  $w_1 = 3 \text{ k/ft}$  and  $N = 15 \text{ k}$ , what are the magnitudes of  $w_2$  and  $w_3$  to keep the system in equilibrium.
5. In the structure shown below, calculate the reactions at supports G, H and pin reactions at C, F. Calculate the shear force and bending moment at B.

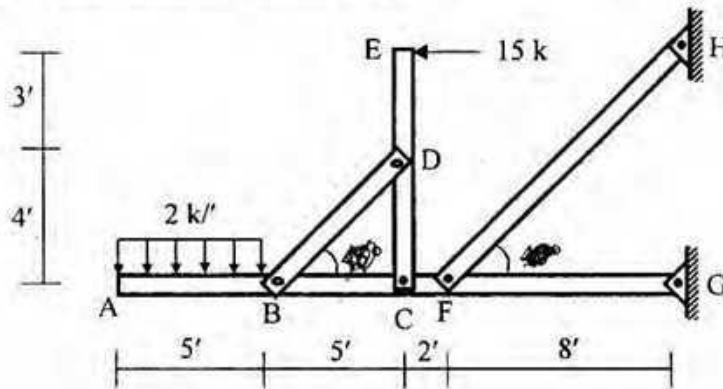

6. In the truss shown below, calculate the reactions at supports D and H and forces in members DH, CD and FG.

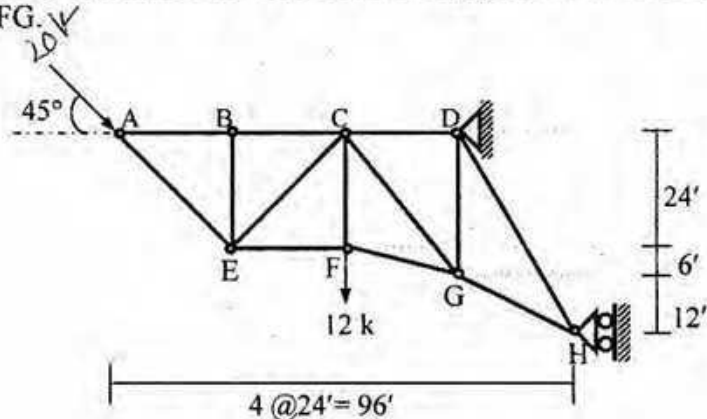

7. Locate the centroid of the structure shown below by centerline dimensions, if the linear members AO', O'B and BC weigh 100 lb/ft and quarter circular members CD and DE weigh 50 lb/ft and 30 lb/ft, respectively.

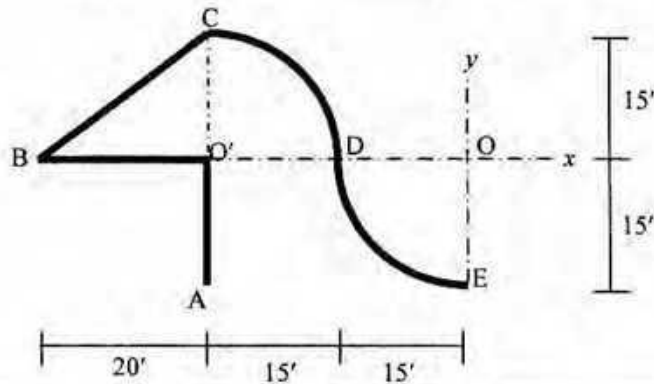

CD and DE are quarter circular arcs with centers O' and O respectively

8. Locate the center of gravity of the hammer shown below, if the unit weight of wood is 50 lb/ft<sup>3</sup> and unit weight of steel is 490 lb/ft<sup>3</sup>.

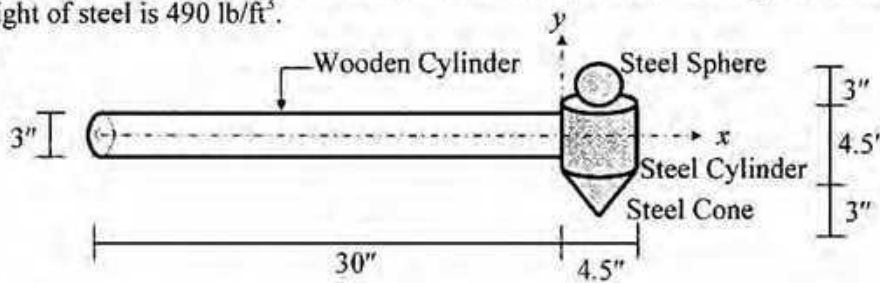

9. Locate the centroid of the shaded area shown below.

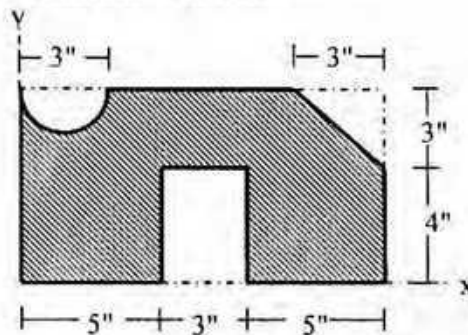

10. Calculate the ~~value~~ coordinates of the centroid of the area bounded by the curves  $y^2 = 16x$  and  $y = 2x$ .

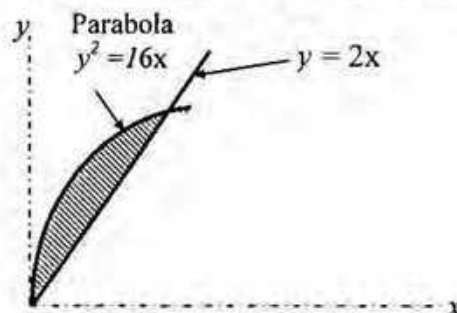

11. Calculate the moments of inertia and radii of gyration about the  $x$ -axis and  $y$ -axis of the shaded area shown in Question 9.
12. The location of centroid for the shaded section shown in the following figure is given by  $\bar{x} = 3.65'$ ,  $y = 4.24'$ , while centroidal moments of inertia are  $\bar{I}_x = 283.19 \text{ ft}^4$ ,  $\bar{I}_y = 263 \text{ ft}^4$ . Calculate the minimum moment of inertia of the section and show the corresponding principal axis.

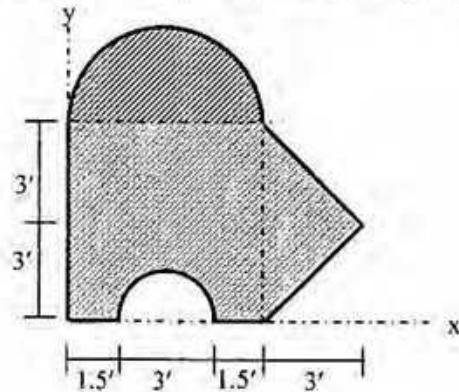

13. The cable AOB shown below carries a uniformly distributed load ( $w$ ) of  $3 \text{ lb/horizontal ft}$ . The tension in the cable at the support B is  $15,000 \text{ lb}$ . Calculate the distance between the two supports, the length of the cable and the tension at the support A.

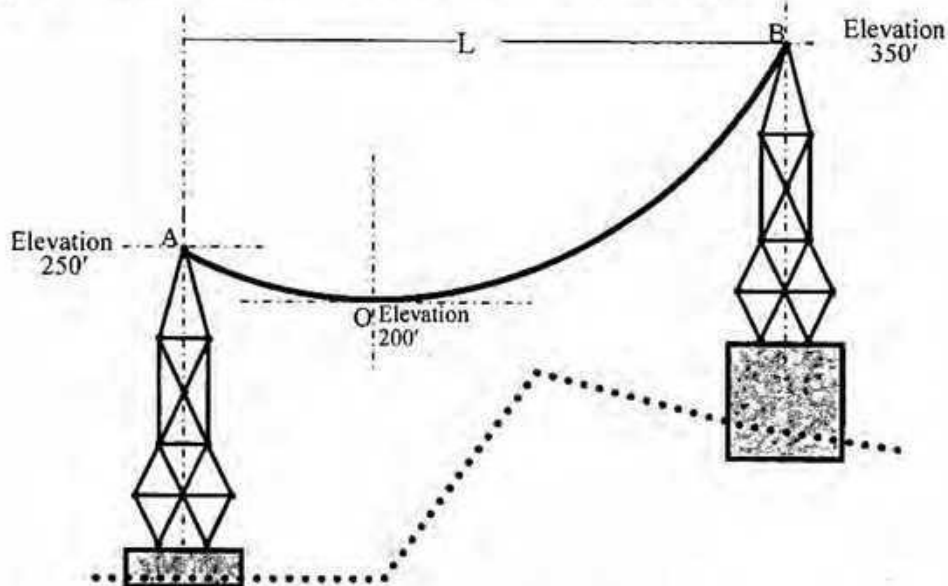

14. Answer Question 13 assuming the uniformly distributed load ( $w$ ) to be  $3 \text{ lb/ft}$  of cable length.

## Formulae

$$1. I = \bar{I} + Ad^2$$

$$2. P_{x'y'} = \bar{P} + Ad_x d_y$$

$$3. I_{x'} = I_x \cos^2 \theta - P_{xy} \sin 2\theta + I_y \sin^2 \theta$$

$$4. I_{y'} = I_x \sin^2 \theta + P_{xy} \sin 2\theta + I_y \cos^2 \theta$$

$$5. I_{x'} + I_{y'} = I_x + I_y$$

$$6. \tan 2\theta = \frac{2P_{xy}}{I_y - I_x}$$

$$7. F^2 = Q^2 + w^2 x^2$$

$$8. \tan \theta = \frac{wx}{Q}$$

$$9. \tan \theta' = \frac{4d}{L}$$

$$10. y = \frac{wx^2}{2Q}$$

$$11. s_{\max} = L + \frac{8d^2}{3L} - \frac{32d^4}{5L^3}$$

$$12. y = \frac{k}{2} \left( e^{\frac{x}{k}} + e^{-\frac{x}{k}} \right) = k \cosh \frac{x}{k}$$

$$13. \tan \theta = \frac{ws}{Q}$$

$$14. F^2 = Q^2 + w^2 s^2$$

$$15. F = wy$$

$$16. y = k + d$$

$$17. s = \frac{k}{2} \left( e^{\frac{x}{k}} - e^{-\frac{x}{k}} \right) = k \sinh \frac{x}{k}$$

$$18. y^2 = (s^2 + k^2)$$

$$19. k = \frac{Q}{W}$$

**The University of Asia Pacific**  
**Department of Civil Engineering**  
**Final Examination Fall 2009**  
**Program: B.Sc. Engineering (Civil)**

Course Title: Engineering Mechanics II  
 Time: 3.0 hours

Course Code: CE 103

Credit: 3.00  
 Full Marks: 100

There are **FOURTEEN** questions. Answer any **TEN**.  
 The figures in the right margin indicate the marks of the questions.

1. In the following figure, what force  $P$  will cause the block  $B$  to impend downward? (10)

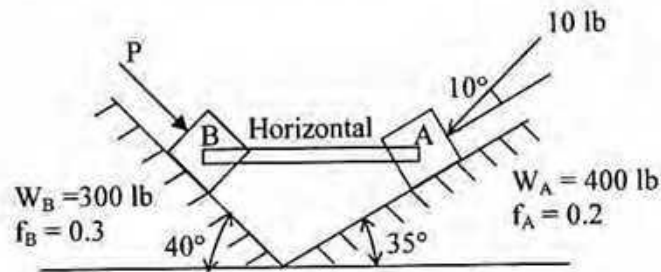

2. For the following figure, what is the weight of  $B$ , if the block  $A$  impends downward? Will the block  $A$  slide or tip over? (10)

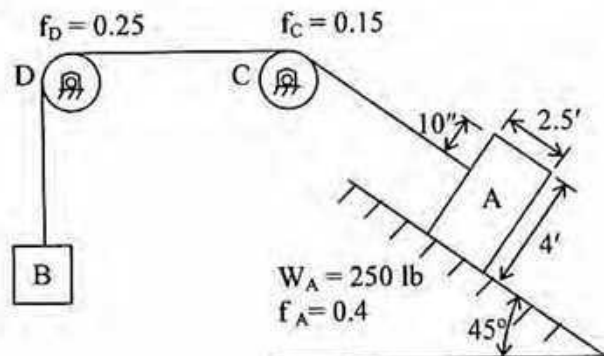

3. (a) If a cast iron cylinder is 15" in diameter and 50" in length, what is its mass moment of inertia about the geometric axis? What is the corresponding radius of gyration? Cast iron weighs 450 lb/ft<sup>3</sup>. (3)
- (b) A 45° sector of a cast iron disk with a radius of 25" is used to balance the reciprocating part of a certain engine as shown in the following figure. Find the mass moment of inertia about the z axis. Unit weight of cast iron is 450 lb/cft. (7)

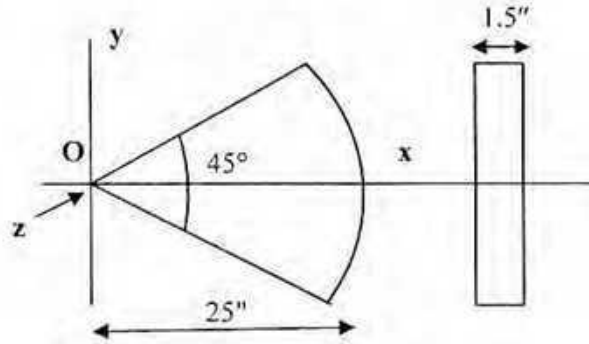

4. The sliding members A and B of the following figure are constrained to move in the x and y directions, respectively. They are connected by the rod C whose length is 12 ft. At the instant when  $x = 10$  ft,  $v_A = 30$  fps toward the right and  $a_A = 15$  fps<sup>2</sup> toward the left. Determine the velocity and acceleration of B at this instant. (10)

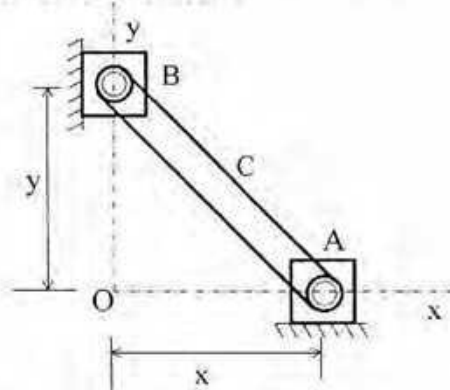

5. In the following figure,  $W_A = 350$  lb,  $W_B = 200$  lb,  $f_A = 1/3$ ,  $f_B = 1/4$ . How far and in what direction does B travel from rest during 30 sec? Find also the forces in the cable C and in the cable D. The cables are weightless and the pulleys are weightless and frictionless. (10)

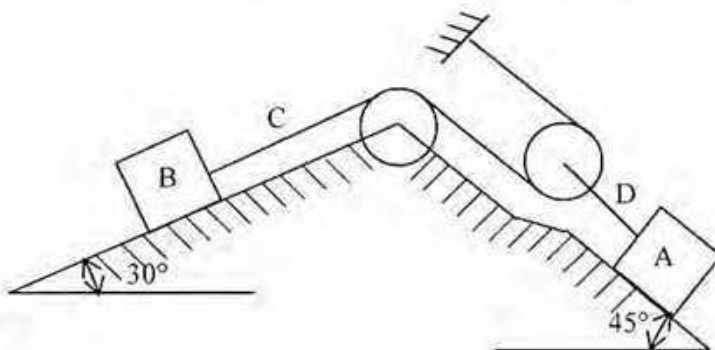

6. In the following figure, the body **B** is moving rightward at 40 fps. The weight of the cable and pulleys and the friction at the pulleys are negligible. (10)

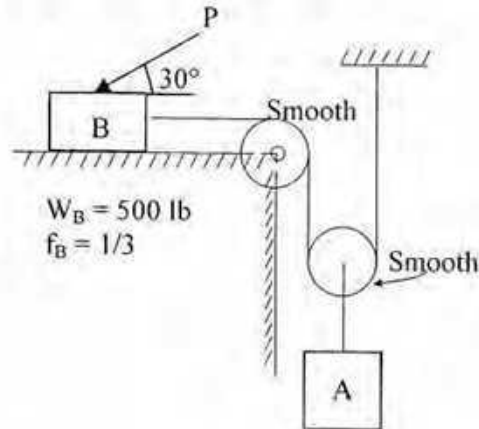

- What constant force  $P$  will bring the bodies **A** and **B** to rest, when the body **B** has a displacement of 30 ft rightward?
- What are the tensions in the cables attached to **A** and **B**?

7. In the following figure,  $W_A = 300 \text{ lb}$ , guide **C** for the weightless cable is smooth. The bodies **A** and **B** are moving leftward with an initial speed of 30 fps. After each of these bodies has each moved 200 ft, neither one changing its direction, their speed is 15 fps. (10)
- What is the weight of the body **B**?
  - What are the tensions in the cables **AC** and **BC**?
  - What is the change of potential energy of the system?

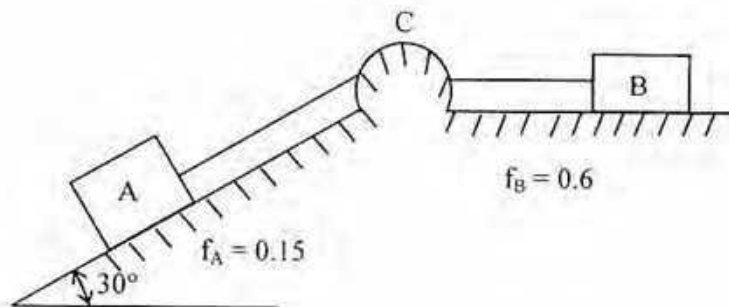

8. In the figure given below, the diameter of the inner drum within a rotating assembly is 3.5'. A weight  $W = 40$  lb is suspended with a cable from the drum. Neglect the friction and mass of the cable. The radius of gyration of the rotating assembly is 2.5'. (10)

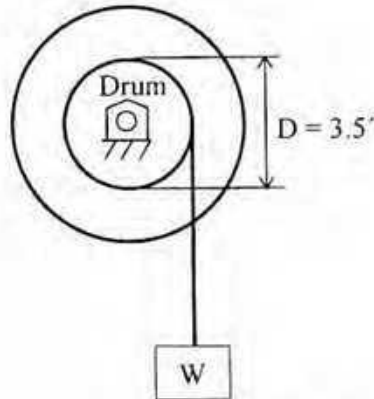

If  $W$  is released from rest and descends 20 ft in 5 sec, calculate-

- the weight of the rotating assembly.
  - the tension in the cable.
9. A disk  $A$  has a weightless cord wrapped about its mid-section. This cord passes over a frictionless and weightless sheave  $C$  and thence downward to a 120 lb weight  $B$ .  $I_A = 4$  slug/ft<sup>2</sup>. The displacement of  $B$  is 15 ft. (10)
- If the system starts from rest, what is the final speed of the c.g of  $A$  and the acceleration of  $B$ ?
  - What is the tension in the cable?

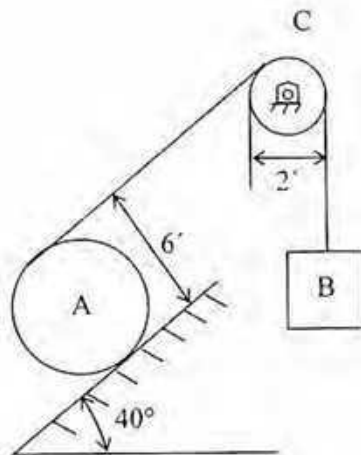

10. In the following figure, the pulleys C and D are frictionless and weightless. (10)
- If block B moves 30 ft from rest up the incline in 15 sec, what is the weight of block A?
  - What are the forces in the cables attached to the blocks A and B?
  - What is the change of potential energy for the whole system?

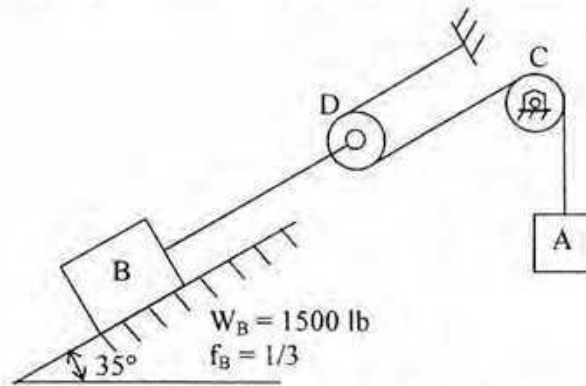

11. Two bodies A and B, having the velocities of 20 fps and 25 fps respectively are moving (10)
- towards each other in the same line of motion and consequently strike. Coefficient of restitution is 0.4. These bodies are sliding on a horizontal plane, where  $f = 0.25$ . The impact is direct and central.
- How far apart are the bodies when they come to rest?
  - What is the loss of kinetic energy during impact?

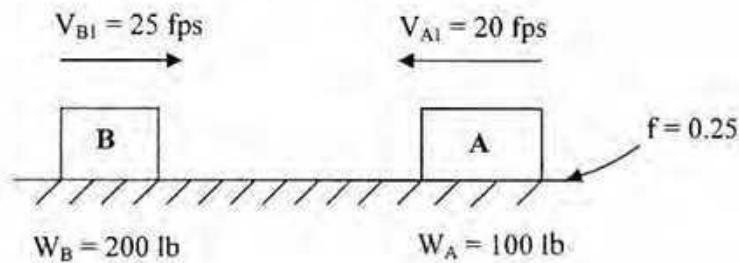

12. Two smooth spheres A and B of equal diameter and on a horizontal plane collide with oblique (10)
- central impact, as shown in the following figure. Each sphere weighs 15 lb. Coefficient of restitution is 0.75.

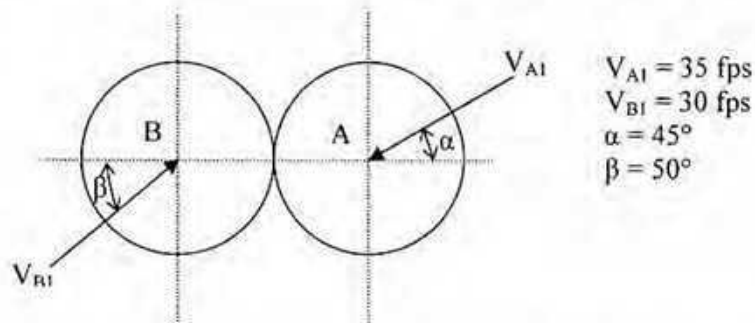

What are the absolute velocities (including directions) of each sphere after impact?

13. As shown in the following figure, the weight  $W = 120$  lb is placed on a triangular table with legs at A, B and C. Find the reactions at supports A, B and C. (10)

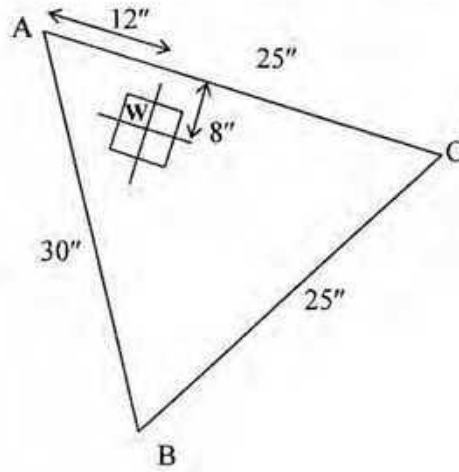

14. The following figure represents a boom that supports a load  $W = 700$  lb. If  $AB = BC = 8$  ft,  $BD = 7$  ft, and  $BE = 4$  ft., find the tension in cable  $DE$  and the force in members  $AE$  and  $CE$ . (10)

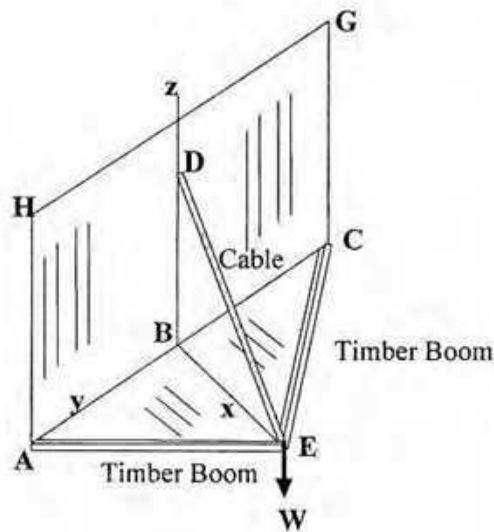

**The University of Asia Pacific**  
**Department of Civil Engineering**  
**Final Examination Fall 2009**  
**Program: B.Sc. Engineering (Civil)**

Course Title: Surveying  
 Time : 3 Hours

Course Code: CE 105  
 Full Marks: 150

*There are two sections in the question paper namely "SECTION A" and "SECTION B". You have to answer from both sections according to the instruction mentioned in each section.*

**SECTION A**

There are FOUR questions in this section. Answer any THREE.

1. (a) Explain how the procedure of reciprocal leveling eliminates the effects of atmospheric refraction and earth's curvature. (8)
- (b) How can you erect a perpendicular to a chain line from a point on it by chain? (5)
- (c) A rectangular plot EFGH forms the plane of a pit cut for construction work. B is point of intersection of the diagonals. Calculate the volume of the excavation in cubic meters by Prismoidal formula from the following data. Lengths of two sides of rectangle are 52 m and 85 m, respectively. (12)

Point	E	F	G	H	B
Original level	46.3	49.5	52	47.2	52.2
Final Level	38.6	40.8	42.7	41.6	43

2. (a) Explain the "closing error" of a compass survey. Show how you can adjust it by Graphical Method. (7)
- (b) A closed traverse was conducted around an obstacle and the following observations were made. Work out the missing quantities: (12)

Side	Length (ft)	W.C.B
AB	-	33 <sup>o</sup> 45'
BC	300	86 <sup>o</sup> 23'
CD	-	169 <sup>o</sup> 23'
DE	450	243 <sup>o</sup> 54'
EA	268	317 <sup>o</sup> 30'

- (c) What are the sources of cumulative errors in a long chain survey? (6)
3. (a) What are the differences between Height of Instrument Method and Rise and Fall Method? (3)
- (b) Describe the following methods as used in plane table surveying. (6)  
 i) Intersection ii) Radiation
- (c) The following consecutive readings were taken with a level (16)  
 6.21, 4.92, 6.12, 8.42, 9.81, 6.63, 7.91, 10.21, 9.22, 7.32, 6.45  
 The level was shifted after 4<sup>th</sup>, 6<sup>th</sup> and 9<sup>th</sup> readings. The reduced level at first point was 100 ft. Calculate the reduced levels of the points by using height of instrument method and apply usual arithmetic check.

4. (a) What is contour? What are the characteristics of contour? (2+5)  
 (b) Explain with diagrams the construction and working principle of an optical square. (8)  
 (c) An instrument was setup at P and the angle of elevation to a flag 3 m above the foot of the staff held at Q was  $7^{\circ} 30'$ . The horizontal distance between P and Q was known to be 4500 m. Determine the reduced level of the staff station at Q. Given that the R.L of the instrument axis was 2650.38 m (7)  
 (d) The magnetic bearing of a line AB is  $S 48^{\circ} 50' E$ . Calculate the true bearing if the declination is  $8^{\circ} 39' E$ . (3)

### SECTION B

There are **FOUR** questions in this section. Answer any **THREE**.

Assume reasonable values for missing data (if any)

5. (a) Why are circular curves required? For a simple curve, define (i) Tangent distance, (ii) Deflection angle, (iii) Mid Ordinate and (iv) Long chord. (5)  
 (b) Two tangents intersect at chainage 85+75, the deflection angle being  $58^{\circ} 25'$ . Calculate the necessary data for setting out a curve of 40 chain radius to connect the two tangents, if it is intended to set out the curve by offset from chords. Consider peg interval equals to 100 links, length of the chain being equal to 20 m (100 links). (12)  
 (c) A transition curve is required for a circular curve of 250 m radius, the gauge being 250 cm and maximum super-elevation restricted to 150 mm. The transition curve is to be designed for a velocity such that no lateral pressure is imposed on the rails and the rate of gain of radial acceleration is  $25 \text{ cm/sec}^3$ . Calculate the required length of the transition curve and the design speed. (8)
6. (a) What is transition curve? Why is it provided? What is super-elevation? (5)  
 (b) Two tangents intersect at chainage 80+60, the deflection angle being  $50^{\circ} 25'$ . Calculate the necessary data of various chord lengths and tangential angles for setting out a curve of 30 chain radius to connect the two tangents, if it is intended to set out the curve by Rankin's method of tangential angles. Consider peg interval equals to 100 links, length of the chain being equal to 20 m (100 links). (20)
7. (a) Define (i) Latitude and Longitude (ii) Celestial Horizon (iii) Altitude and Azimuth (5)  
 (b) Find the shortest distance between two places **R** and **S**, given that the latitude of **R** and **S** are  $30^{\circ} 0' N$  and  $40^{\circ} 25' N$  and their longitudes are  $55^{\circ} 0' E$  and  $58^{\circ} 21' E$  respectively. Also find the direction of **R** on the great circle route. (15)  
 (c) Find the zenith distance and altitude at the upper transit of the star having the declination of  $65^{\circ} 40' N$  and the latitude of  $26^{\circ} 40' N$ . (5)
8. (a) Define crab and drift. What are the reasons for overlapping? (5)  
 (b) A camera having focal length of 20 cm is used to take a vertical photograph to a terrain having an average elevation of 1500 m. What is the height above mean sea level at which an aircraft must fly in order to get the photograph at a scale of 1:7500? (5)  
 (c) An aircraft has been planned to fly over a defined territory to prepare a map of that area. The flying height has been adjusted to a height of 200 m from water surface. Again the elevation of the ground surface is 300 m relative to a predefined datum. The territory covers an area of 12.5 km x 15.5 km. The scale of the photograph is 1 cm = 300 m. The photograph size is 18 cm x 18 cm. Determine the number of photographs to cover the area, if the desired overlap is 65% and the side lap is 30%. (15)

**Given formula:**

$$1. \cos P = \frac{\cos p - \cos a * \cos b}{\sin a * \sin b}$$

$$2. \tan(A+B)/2 = \cot(P/2) * \frac{\cos(a-b)/2}{\cos(a+b)/2}$$

$$3. \tan(A-B)/2 = \cot(P/2) * \frac{\sin(a-b)/2}{\sin(a+b)/2}$$

$$4. z = \delta - \theta, \quad \alpha = 90^\circ - z$$

$$5. T = R \frac{\Delta}{2}, \quad l = \frac{\pi R \Delta}{180^\circ}, \quad \delta = 1718.9 \frac{c}{R}$$

$$6. O_1 = \frac{c^2}{2R}, \quad O_2 = \frac{C}{2R}(c+C), \quad O_3 = \dots = O_{n-1} = \frac{C^2}{R}, \quad O_n = \frac{c'}{2R}(C+c')$$

$$7. L_{transition} = \frac{v^3}{\alpha R}, \quad \Delta_c = 1719 \frac{L}{R}, \quad \Delta_c = \Delta - 2\Delta_s, \quad L_{circular} = \frac{\pi R \Delta_c}{180^\circ}, \quad s = \frac{L^2}{24R},$$

$$\tan \theta = \frac{v^2}{gR}$$

$$8. T = (R+s) \tan \Delta + \frac{L}{2}$$

$$9. s_h = \frac{f}{H-h}, \quad L = (1-p_l)sl, \quad W = (1-p_w)sw$$

$$10. a = L \times W, \quad N = \frac{A}{a}$$

$$11. N_1 = \frac{L_1}{(1-p_l)sl} + 1, \quad N_2 = \frac{L_2}{(1-p_w)sw} + 1$$

$$12. \text{Level Section} \quad A = (b + nh) h$$

$$13. \text{Two-Level Section} \quad A = \{n (b/2)^2 + m^2 (b+nh)h\} / (m^2 - n^2)$$

$$14. \text{Three-Level Section} \quad A = \{b (h_1+h_2)/4 + h (w_1+w_2)/2\}$$

$$w_i = m_i n / (m_i - n) (h + b/2n)$$

$$h_1 = m_1 n / (m_1 - n) (h + b/2m_1)$$

$$h_2 = m_2 n / (m_2 - n) (h - b/2m_2)$$

$$15. V = \frac{d}{6} (A_1 + A_2 + 4A_m)$$

**Note:** Here the symbols have their usual meanings.

**The University of Asia Pacific**  
**Department of Civil Engineering**  
**Final Examination Fall- 2009**  
**Program: B.Sc. Engineering (Civil)**

Course Title: Introduction to Civil &  
Environmental Engineering

Course Code: CE 107

Credit: 2.00

Time: 2 hours

Full Marks: 50

---

There are **TWO** sections in the question paper namely "SECTION A" and "SECTION B". You have to answer from the both sections according to the instruction mentioned on each section.

---

**SECTION A**

Total Marks: 15

Answer any THREE

1. Define contract. Write down the name of various types of contract. (5)
2. a. Define planning and scheduling of a project with example? (5)  
b. Write down the organogram of Bangladesh Inland Waterway Transport Corporation. (5)
3. Write down the name of few types of equipment commonly used in construction works. The use of equipments in construction work has no benefits- Do you agree with this statement, explain. (5)
4. Describe the road transportation network in Bangladesh. (5)

**SECTION B**

Total Marks: 35

Answer all questions and follow the instructions.

(2x4=8)

1. Describe the following (any four):
  - a. Meteorological and hydrological drought
  - b. Sustainability and the urban world as environmental issues
  - c. Age Structure
  - d. Possible effect of sea level rise in Bangladesh
  - e. Water resources in Bangladesh
  - f. Photochemical and sulfurous smog

(5)

2. Assume that a population follows a simple logistic growth curve. Find the maximum sustainable yield as a function of carrying capacity, the current population size and current growth rate.

or

Suppose the fish population in a pond follows a logistic curve until it stabilizes at 15,000. This year the numbers of fishes are 5,000 and its growth rate is 1.7%. When the fish number will reach 7,500 and 14000?

(2+4=6)

3. Define water pollution? Write any four different categories of water pollutant along with their sources and impact.

(3x2=6)

4. Answer any two of the following:

- Define ecosystem and what are its components?
- If flood water puts raw sewage into a natural flowing stream what will be the possible relationship between dissolve oxygen and biochemical oxygen demand (BOD) along the up and downstream from the point of pollution.
- Show in an idealized diagram selected aspects of acid rain formation and paths.

(5x2=10)

5. Answer any two of the following:

- What is meant by *greenhouse gas*? Discuss these gases in terms of their potential to cause global warming?
- Briefly discuss the important rural environmental issues in Bangladesh.
- Define global warming. "The trapping heat in the atmosphere is somewhat analogous to a greenhouse" – explain.

**The University of Asia Pacific**  
**Department of Civil Engineering**  
**Final Examination Fall- 2009**  
**Program: B.Sc. Engineering (Civil)**

Course Title: Introduction to Civil &  
Environmental Engineering

Course Code: CE 107

Credit: 2.00

Time: 1 hour

Full Marks: 40

---

There are **TWO** sections in the question paper namely "SECTION A" and "SECTION B". You have to answer from the both sets according to the instruction mentioned on each section.

---

**SECTION A**

Marks: 15

Answer any THREE.

1. Briefly discuss the important rural environmental issues in Bangladesh. Define renewable and non-renewable energy with examples. (5)
2. What are the general effects of air pollution? Describe different sources of air pollution. (5)
3. What is acid rain? Show in a schematic diagram how photochemical and sulfurous smog develops? (5)
4. Define global warming. "The trapping heat in the atmosphere is somewhat analogous to a greenhouse" – explain. (5)

**SECTION B**

Marks: 35

Answer all questions and follow the instructions.

(5+3+4=12)

1. a. Give the names in details of the following codes with their related fields,  
i. AASHTO    ii. ACI    iii. AREA    iv. ASTM    v. BNBC  
b. How can you ensure satisfactory quality of cement in the field?  
c. One foreign company proposes the implementation of an underground transportation system under build and transfer basis (BOT) to ease the traffic congestion in Dhaka city. Mention the various steps to be followed by the company during the implementation of the project.  
d. Define the following terms:  
i. Height of the Building    ii. Floor Area Ratio (FAR)  
iii. High rise building    iv. Road width

**Or,**

(3+3+3+3=12)

1. a. Define contract. Write down the name of various types of contract.
- b. What do you mean by planning and scheduling of a project?
- c. Write down the organogram of Bangladesh Roads & Highways Department (RHD).
- d. Describe the road transportation network in Bangladesh.

(10)

2. The University of Asia Pacific is planning to construct an eight storied building under its own supervision. As its fund is limited, the university wants to take loan from a financial institution. Financial institution provides maximum 70% loan of the total construction cost. Estimate the total construction cost and the amount of money to be borrowed as per the PWD schedule (enclosed). The particulars of the building are as follows:

Sl No	Particulars	Specifications
01	Land Size	55 m x 65 m
02	Road width	20 m
03	Building type	Educational (Superior)
04	Allowable Bearing Capacity ( $Q_a$ )	3.5 ksf
05	Floor Level	Eight
06	Plinth Area	1840 Square meter (40 m x 46 m)
07	Type of structure	RCC Frame Structure, Concrete with Stone Chips, $f_c=22-25$ MPa
08	Ground Floor	50% Car Parking and 50% Habitation
09	Lime terracing, RCC cornice and parapet	0.92 m height
10	Roof top RCC water tank including beams and supports etc	12,000 Gallons
11	For mosaic work in all rooms including stair, tiles in bathrooms and normal finishing	Tk.950 per square meter
12	Underground water reservoir, distribution line, water pump, pump house, WASA charge	1,30,000 Gallons
13	Boundary wall	RCC frame

(1+1+4+1+2+1+3=13)

3. Mr. Rahim purchased a 40 m wide (front side) and 50 m long plot. The adjacent road is 12 m wide. He wants to construct a five storied residential building (Type A2) on his plot. His architect wants to prepare a drawing sheet for RAJUK approval. Calculate the followings for the Architect:
  - (i) Minimum front set back as per RAJUK rules?
  - (ii) Back and side set backs as per RAJUK rules?
  - (iii) If you keep front, back and side set back as per RAJUK minimum setback rules, then what will be the ground coverage of the building? Does it comply with maximum ground coverage as per RAJUK rules, explain? If not, then what will be the back set back (take 0.25 m rounding) if, front setback 12.5 m and side setback 5 m in each side. Draw layout plan and find out the plinth area of the building as per RAJUK ground coverage rules?

- (iv) What is the Floor Area ration (FAR) of the building for 50% ground coverage? Does it comply with RAJUK rules, explain? Do not consider ground floor area while calculating total floor area.
- (v) What is the available and minimum required parking space? Assume, (a) Generator room 30 sqm (b) Guard room 5 sqm (c) Driver waiting room 5% of the plinth area (d) stair and lift area (total) 100 sqm (e) Apartment size 250 sqm (gross) and No of apartment in each floor is 4 (FOUR). (f) drive way 60% area of paring space. (g) 50 % ground coverage.
- (vi) Find the maximum number of floor levels that can be constructed. Assume ground floor area is reserved for car paring and other purposes and do not consider ground floor area while calculating total floor area.
- (vii) If he wants to construct fifteen storied building, then what will be the ground coverage? Assume ground floor area is reserved for parking and other purposes and do not consider ground floor area while calculating total floor area.

**Table:** FAR, Maximum Allowable Land Use and Minimum Width of Adjacent Road (Source: RAJUK)

Building Occupancy Type		1300to≤2600 Sq. metre			≥ 2600 Sq. metre		
		FAR	Max <sup>m</sup> Land Use (%)	Min <sup>m</sup> Road Width (m)	FAR	Max <sup>m</sup> Land Use (%)	Min <sup>m</sup> Road Width (m)
Type A : Residential	A1-A4	5.5	50	12	6.0	50	18
	A5	5.0	50	12	-	50	18

**Table:** PARKING AND TRAFFIC REGULATION STANDARD

Car Type	Parking width	Parking Length	Area
Car	2.4 m	4.8m	11.52 sqm
Bus & Truck	3.6 m	10.0m	360 sqm

**Table:** MINIMUM PARKING REQUIREMENTS

Occupancy Type	Building Type	Minimum Parking Requirements
Residential buildings	Type A	
Flats with gross floor area exceeding 200 sqm		1 Car parking for each unit

**Table:** MINIMUM SETBACK

**A. FRONT SETBACK:**

The minimum setback is the larger value of 4.5 metres from the centre of the road or 1.5 meter from the front property line.

**B. FOR SIDE SETBACK UPTO 10 STORIED OR 33.00 M HIGH BUILDING:**

Size of the plot (sqm)	Minimum back setback (m)	Side setback(m)
1301 and higher	2.00	1.50

**The University of Asia Pacific**  
**Department of Civil Engineering**  
**Final Examination Fall 2009**  
**Program: B. Sc. Engineering (Civil)**

Course Title: Engineering Materials  
Time: 3 Hours

Course Code: CE 201  
Full Marks: 150

There are EIGHT Questions. Answer SIX QUESTIONS including Question No. 1 and Question No. 2. QUESTIONS 1 & 2 are COMPULSORY.

- 1 Concrete mix design is required for a six-storied building construction project in Dhaka. The following basic data for the mix design are available: (40)

Volume ratio of sand to total aggregate = 0.38  
Air Content = 2%  
Specific gravity of cement = 3.1  
Specific gravity of sand (SSD) = 2.6  
Specific gravity of coarse aggregate (SSD) = 2.6  
Design compressive strength (28 days) = 4500 psi  
Minimum required slump = 175 mm  
Maximum aggregate size =  $\frac{3}{4}$  inch  
Aggregate type = stone chips

The following graphs are provided :

- Variation of compressive strength (28 days) with W/C.
  - Variation of cement content with compressive strength (28 days) for different aggregate size and slump value
- (i) Design a concrete mix and prepare a mix proportion table with the necessary information of the mix and required properties of the mix.
  - (ii) Calculate the volume ratio of the mix (assume unit weights of cement, sand (dry), and coarse aggregate (dry) with void are  $1350 \text{ kg/m}^3$ ,  $1250 \text{ kg/m}^3$  and  $1450 \text{ kg/m}^3$ , respectively. Assume absorption capacity of 2% for both the coarse aggregate and fine aggregate.
  - (iii) Calculate the cost of concrete per cubic meter. Assume the cost of 1 bag cement = Tk. 410, cost of 1 cft SSD sand = Tk. 30, and cost of 1 cft SSD stone chips = Tk. 70.
  - (iv) Estimate the materials in weight and volume (cement, water, sand, and coarse aggregate) required to cast a slab of 30 ft by 40 ft with thickness 6 inch.
  - (v) Assume 4% of surplus water in sand over SSD condition and the amount of bulking of sand = 10%. What adjustments are necessary in the volumetric and weight based mix designs?

2

For a bridge construction project, the recommended FM for sand is 2.6. From a nearby market, two sand samples (Sand 1 and Sand 2) were collected. The samples were sent to the Concrete Laboratory of The University of Asia Pacific (UAP) for sieve analysis. The sieve analysis data are given below:

(22)

ASTM Sieve	Amount Retained (g)	
	Sand 1	Sand 2
3 inch	0	0
1.5 inch	0	0
1.0 inch	0	0
¾ inch	0	0
½ inch	0	0
3/8 inch	0	0
#4	70	0
#8	70	0
#12	70	70
#16	70	70
#30	70	70
#40	70	70
#50	0	35
#100	0	35
#200	45	100
Pan	45	0

- (i) Calculate FM of the sand samples (Note : It is necessary to screen the sand samples by #4 sieve to calculate the FM).
- (ii) Draw the grading curve of the sand samples.
- (iii) In what proportion, the sand samples are to be mixed to get the recommended FM?
- (iv) Comment on the samples based on the sieve analysis data and grading curves.

- 3 (a) Draw typical stress-strain curve of concrete. Discuss the method to calculate Young's modulus of concrete from stress-strain curve. (2.5)
- (b) Discuss the problems associated with high strength concrete and high-strength steel. (2.5)
- (c) Define the following mechanical properties of a material: (5)
  - (i) Creep
  - (ii) Relaxation
  - (iii) Creep coefficient
  - (iv) Ductility
  - (v) Fatigue strength
- (d) Discuss the effect of excess lime, clay, and sand in brick earth. (3)
- (e) Explain the strength development process of brick during burning. (3)
- (f) Why is drying of bricks necessary before burning? (3)
- (g) Explain the causes of efflorescence on bricks. (3)

- 4 (a) Compare fly ash cement and ordinary portland cement. (7)
- (b) Write the hydration reactions of cement. Explain the morphology of cement hydration products. (7)
- (c) Write the ASTM specifications for normal consistency, initial setting time, and final setting time of OPC. (3)
- (d) Write the main steps of cement manufacturing process. (3)
- (e) Discuss the role of gypsum in cement. (2)
- 5 (a) Explain the sulfate attack of concrete with chemical reactions. What kind of cement is to be used to reduce the sulfate attack of concrete? (8)
- (b) During construction site visit of a residential project, the following points were noted: (10)
- (i) Footing 1 – reinforcement is placed at the bottom with a clear cover of 1 inch.
  - (ii) Beam 1 – A 30-minute interval was made after filling the bottom half of the beam before filling the top half.
  - (iii) Beam 2 – construction joint is placed at the mid span of the beam
  - (iv) Column 1 – construction joint is placed just above the beam-column joint.
  - (v) Column 2 – 10-ft high eight column is made in one casting.
  - (vi) Column 3 – segregated concrete is used.
  - (vii) Slab 1 – a lot of bleeding water is found on the surface.
  - (viii) Slab 2 – a cold joint is formed at the center-line of the slabs
  - (ix) Sand – a significant portion of the aggregate is found on #4 sieve
  - (x) Coarse aggregate – a significant amount of particles less than 4.75 mm is found
- (c) Comment on each of the above points.
- (c) Discuss the microstructure of concrete made with a high W/C and a low W/C. (2)
- (d) “Rich concrete is susceptible to autogenous shrinkage” – explain briefly. (2)
- 6 (a) Discuss the changes of workability of concrete for the following situations: (5)
- (i) W/C is increased at site
  - (ii) A finer sand is used
  - (iii) Warm water is used in summer
  - (iv) Dry brick aggregate is used instead of SSD brick chips
  - (v) Sand-to-aggregate volume ratio is reduced.
- (b) “W/C ratio is a key factor related to durability of concrete” – Explain briefly. (3)
- (c) Write short notes on the followings: (7)
- (i) Chemical admixtures
  - (ii) Mineral admixtures
  - (iii) Cold joint
  - (iv) Honeycomb
  - (v) Laitance
  - (vi) Bleeding
  - (vii) Advantages and disadvantages of ready mix concrete
- (d) Explain the ways of making sustainable concrete construction practice in Bangladesh. (5)
- (e) Discuss the functions of cement, water, fine aggregate and coarse aggregate in concrete. (2)

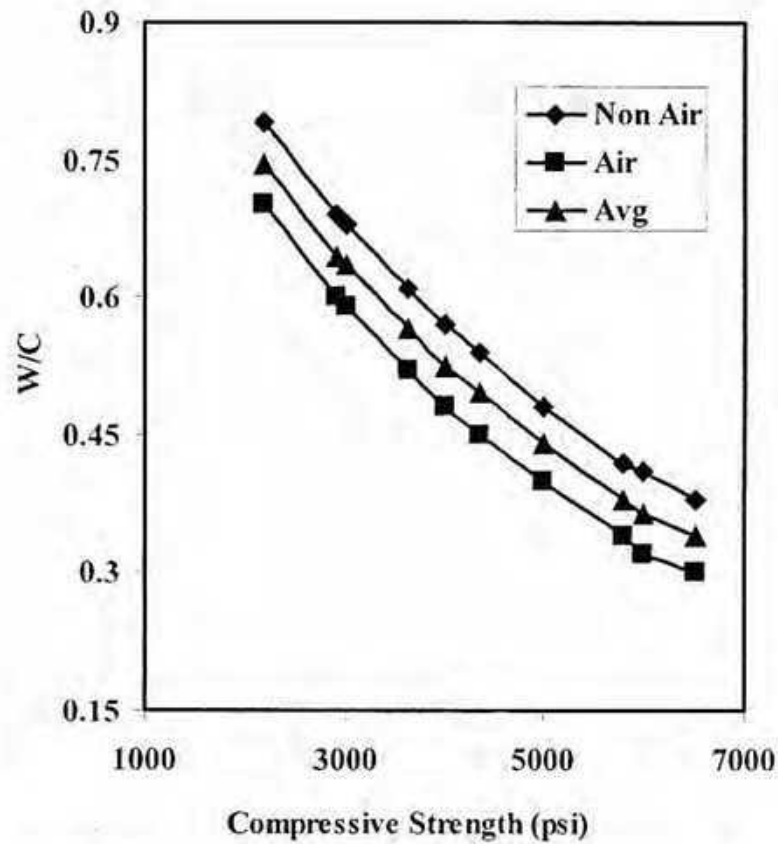

Fig. W/C versus Compressive Strength (aggregate type = stone chips)

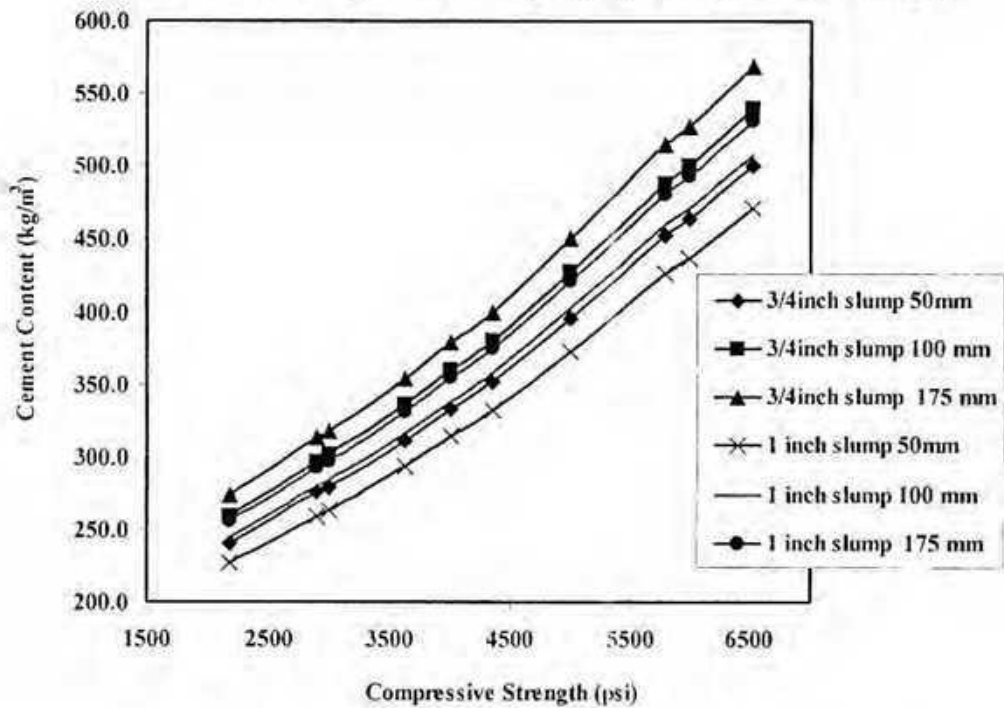

Fig. Cement Content versus Compressive Strength (aggregate type = stone chips)

- 7 (a) You are in-charge of a construction project near the sea in Cox's Bazar. What points are to be considered carefully to make the project durable? (5)
- (b) Discuss the common causes of deterioration of concrete structures in Bangladesh. (4)
- (c) Write a short note on electroplating. (3)
- (d) How are steel bars protected from corrosion in concrete? Explain briefly the chloride-induced and carbonation-induced corrosion of steel in concrete. (4)
- (e) Write a short note on bulking of sand. (2)
- (f) Write short notes on protection of corrosion of steel in concrete using external current and external anode. (4)
- 8 (a) Write short notes on veneer, fly wood and fiber board. (3)
- (b) Discuss the objectives of seasoning of timber. (2)
- (c) Explain the process of formation of annual rings in trees. (3)
- (d) Write short notes on the followings: (14)
- (i) Vulcanization
  - (ii) Metallic bond
  - (iii) Face centered cubic unit cell
  - (iv) Crystal and amorphous structures
  - (v) Atomic radius for the body centered cubic unit cell
  - (vi) Atomic packing factor for the face centered cubic unit cell
  - (vii) Ferrocement and its application.

**The University of Asia Pacific**  
**Department of Civil Engineering**  
**Final Examination Fall 2009**  
**Program: B.Sc. Engineering (Civil)**

Course Title: Numerical Analysis & Computer Programming  
 Time: 3.0 hours

Course No: CE 205  
 Full Marks: 150

There are **EIGHT** questions. Answer any **SIX**.

1. (a) Use Modified Euler method to evaluate the numerical solution of the following ordinary differential equation, for  $x = 0.2$  (15)  

$$y' + x^2y^2 = 2$$
 Here,  $y = 1$  at  $x = 0$ .  
 Desired accuracy,  $\epsilon = 0.0001$ .

- (b) Using iteration method, find the real root of the equation  $xe^x - 1 = 0$ , desired accuracy is 0.0001. (10)

2. Fit the curve  $y = a x^b$  to the following set of points. (25)

x	2	3	5	8	13	21	34
y	13	21	37	59	75	99	115

Find the value of  $y$  corresponding to  $x = 17$ , from the fitted curve.

3. For the following data, (25)

Time (sec)	0	15	30	45	60	75	90
Speed (mps)	0.000	0.0745	0.249	0.561	1.584	3.235	5.428

- (i) Find the Gregory Newton Interpolation polynomial.  
 (ii) Find the speed at times,  $t = 55$  sec and  $t = 70$  sec.

4. (a) Using Bisection method, find the root of the following equation: (15)  

$$3x - \sqrt{1 + \sin x} = 0$$
 Desired accuracy = 0.0001.

- (b) Using the Simpson's rule, evaluate the following integral: (10)  

$$I = \int_0^2 \sqrt{1 + x^2} dx$$
, consider twelve equal subdivisions.

5. Experimentally observed values of deflections of a beam are shown in the following figure. (25)

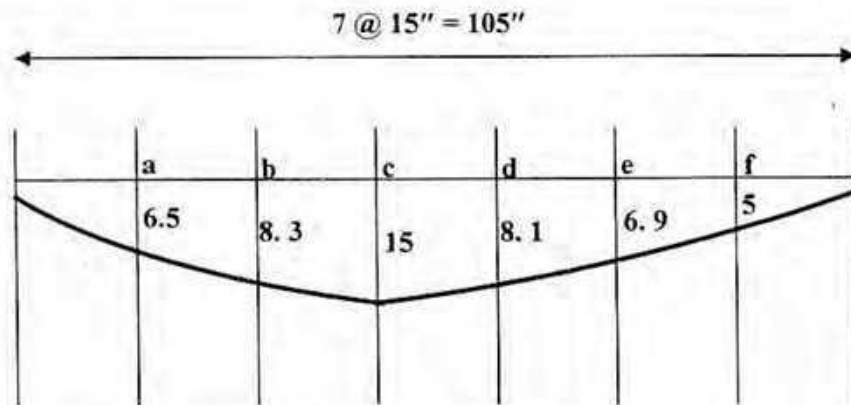

All deflections of the above figure are in ( $\times 10^{-4}$ ) inch.

Using the Difference Table Calculate :

- (i) The bending moments at points c and d.
- (ii) The shear forces at points a and b.
- (iii) The slopes at points d and e.

Given,  $E = 30,000$  ksi,  $I = 2000$  in<sup>4</sup>.

6. Fit a straight line to the following set of points. (25)

x	1	2	3	4	5	6
y	1200	900	600	200	110	50

7. (a) Use Gauss Elimination method to solve the following system of equations: (15)

$$2u + v + w = 10$$

$$3u + 2v + 3w = 18$$

$$u + 4v + 9w = 16$$

- (b) Using Newton Raphson method, find the real root of the following equation: (10)  
 $f(x) = e^x - \cos(\pi x/4)$ , desired accuracy = 0.0001

- 8.(a) The following diagrams show the variation of Bending Moments  $M$  and  $m$  and Moments of Inertia  $I$  in a beam. Estimate deflection of the beam, if  $E = 30,000$  ksi. (10)

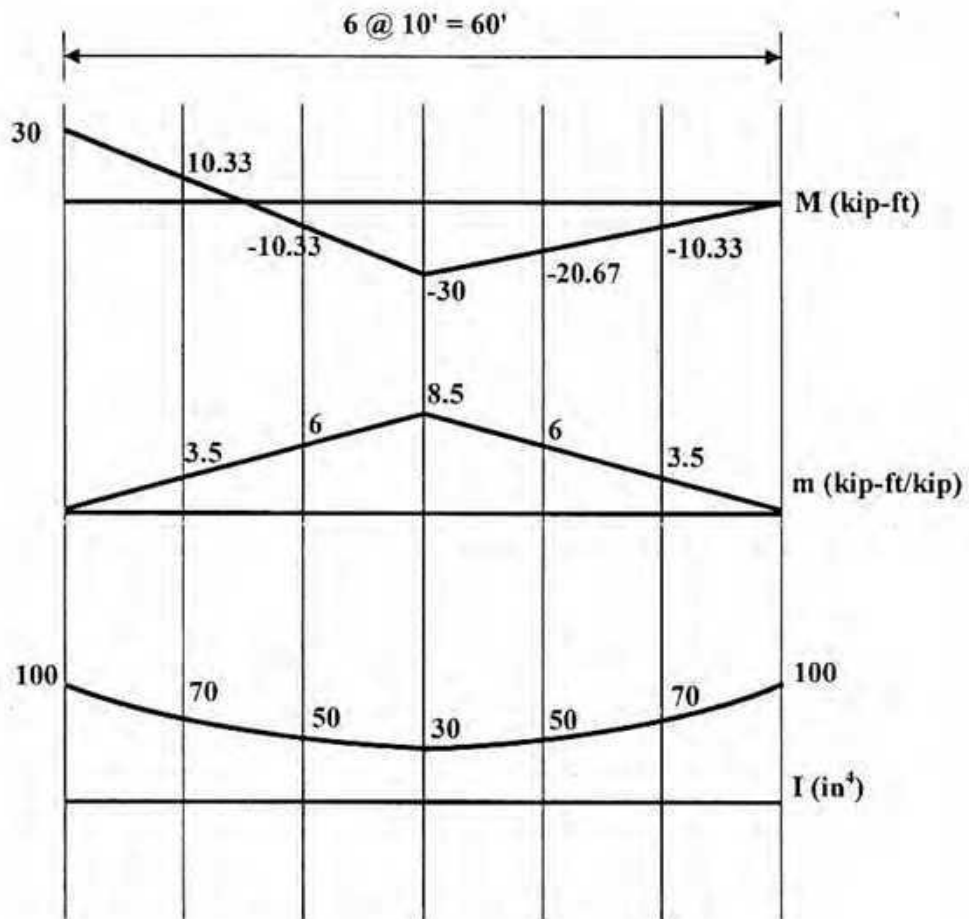

- (b) Using the given data, find the value of  $y$ , corresponding to  $x = 4.79$ . Use Lagrangian Polynomial formula. (15)

$x$	1.7	3.4	5.4	7.2	9.3
$y$	37	49	51	63	76

**Formulae:**

1.  $P(u) = f(x_1) + \{\Delta f(x_1) \cdot u\}/1! + \{\Delta^2 f(x_1) \cdot u \cdot (u-1)\}/2! + \{\Delta^3 f(x_1) \cdot u \cdot (u-1) \cdot (u-2)\}/3! + \dots$

2.  $\Delta^n f(x_1) = {}^n c_0 f(x_1 + n \cdot h) - {}^n c_1 f(x_1 + (n-1) \cdot h) + {}^n c_2 f(x_1 + (n-2) \cdot h) - \dots + {}^n c_n f(x_1)$

**The University of Asia Pacific**  
**Department of Civil Engineering**  
**Final Examination Fall 2009**  
**Program: B. Sc. Engineering (Civil)**

Course Title: Mechanics of Solids II  
 Time: 3 Hours

Course Code: CE 213  
 Full Marks: 100

[Answer any 10 (ten) of the following 14 questions]

1. The compound shaft shown below is attached to rigid supports. Allowable shear stresses of bronze segment and steel segment are 9 ksi and 12 ksi respectively. Determine the diameters of each segment so that each material will be stressed to its permissible limit simultaneously when a torsional moment  $T=15$  k-ft is applied.

Given:  $G_{\text{bronze}} = 5000$  ksi and  $G_{\text{steel}} = 12000$  ksi

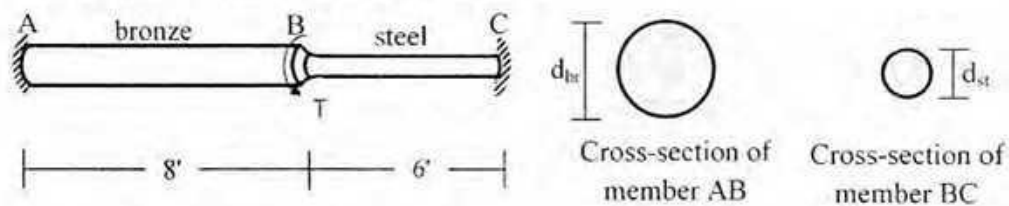

2. For the structure shown below, draw the torsional moment diagram of member ACD and calculate its maximum torsional shear stress and torsional rotation [Given:  $G = 1000$  ksi].

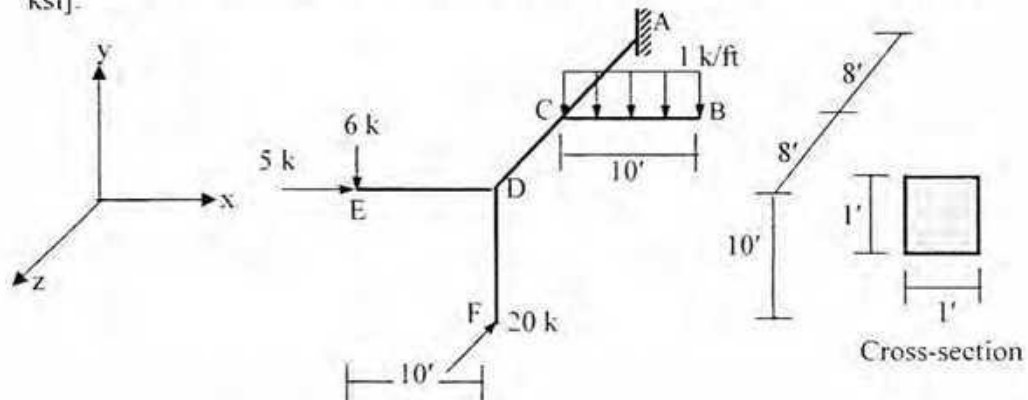

3. For the structure described in Question 2, draw biaxial bending moment diagram of member ACD. Also calculate the combined normal stress at each corner of the section at A.

4. Calculate the maximum shear stress and angle of twist per unit length in the compound section shown in Fig. below when subjected to a torque of 10 k-ft [ $G=12000$  ksi]. Also calculate the diameter (D) of the circular section that has the same maximum shear stress when subjected to the same torque.

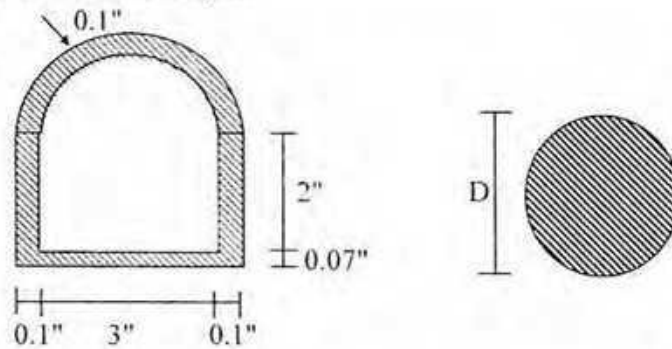

5. The figure below shows a rigid weightless beam ABC as shown being supported by helical spring B and C. If spring C deflects 1.5" (downward) due to the applied loads, calculate the values of

i) P ii) deflection of spring B iii) maximum shear stress at spring B

[Given: Both springs have coil diameter=1", average spring diameter=6", number of coils=9 and shear modulus=12000 ksi].

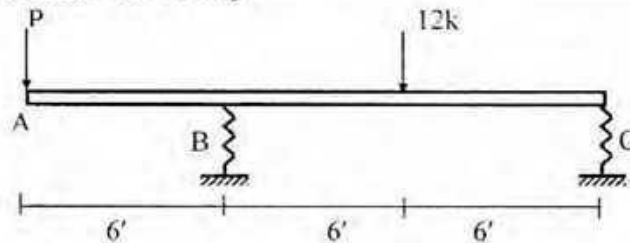

6. The Fig. below shows the stresses on an element. If the maximum principal stress on it is 45 ksi,  
 a) Calculate the stresses on a plane a-a' as shown.  
 b) Show the stresses on plane a-a' graphically using Mohr's circle.

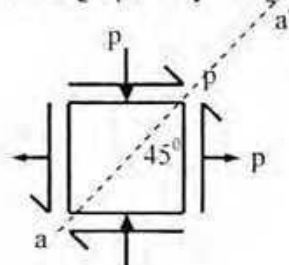

7. For the beam shown below, use the Moment-Area Theorems to calculate the deflection and slope at B and D [Given:  $E = \text{Constant}$ ].

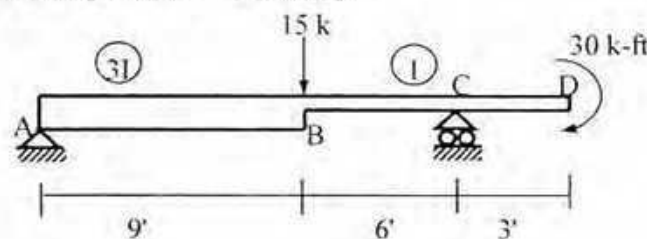

8. For the beam shown below, use the Singularity Functions to calculate the deflection at B and rotation at left and right of B [Given:  $EI = 40 \times 10^3 \text{ k-ft}^2$ ].

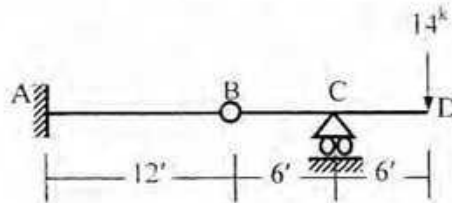

9. Answer Question 8 using the Conjugate Beam Method.
10. Draw the shear force and bending moment diagram of the statically indeterminate beam shown below [Given:  $EI = \text{constant}$ ].

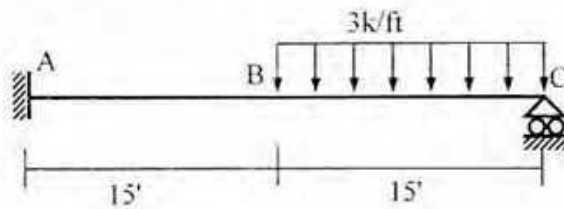

11. For the beams shown below
- Write down the expressions for loading function  $w(x)$  using singularity functions.
  - Write down the corresponding boundary conditions.
  - Determine whether the beams are statically determinate or indeterminate.
  - Draw the qualitative deflected shapes of the beams under the given loads.

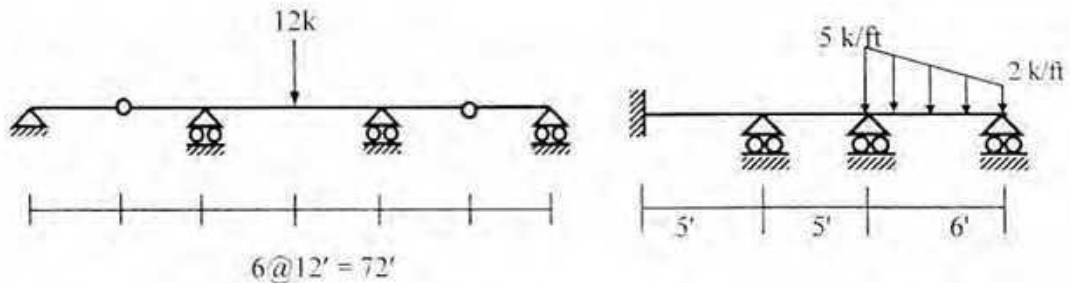

12. A 15-ft long hollow alloy tube was found to extend 0.20" under a tensile load of 14 kips. Assuming buckling to occur, determine the critical load for this tube when used as a strut (compression member) with both ends fixed condition. The elastic properties in tension and compression are identical.

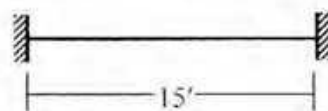

Fixed-ended

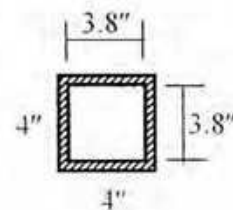

13. In the pin-connected plane structure shown below, determine the maximum allowable load  $F$  that can be applied using the AISC-ASD criteria for buckling [Given: AB and BC are 2"×2" in cross sections, yield strength  $f_y = 40$  ksi, modulus of elasticity  $E = 29000$  ksi].

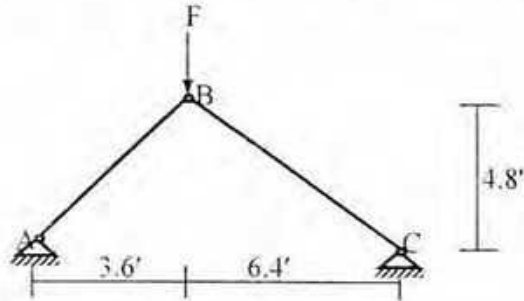

14. In the frame shown below, calculate the effective length factor of column AB about x and z-axis and determine the minimum allowable compressive force on the column according to AISC-ASD criteria [Given:  $E = 30 \times 10^3$  ksi,  $f_y = 40$  ksi, member sections are shown below].

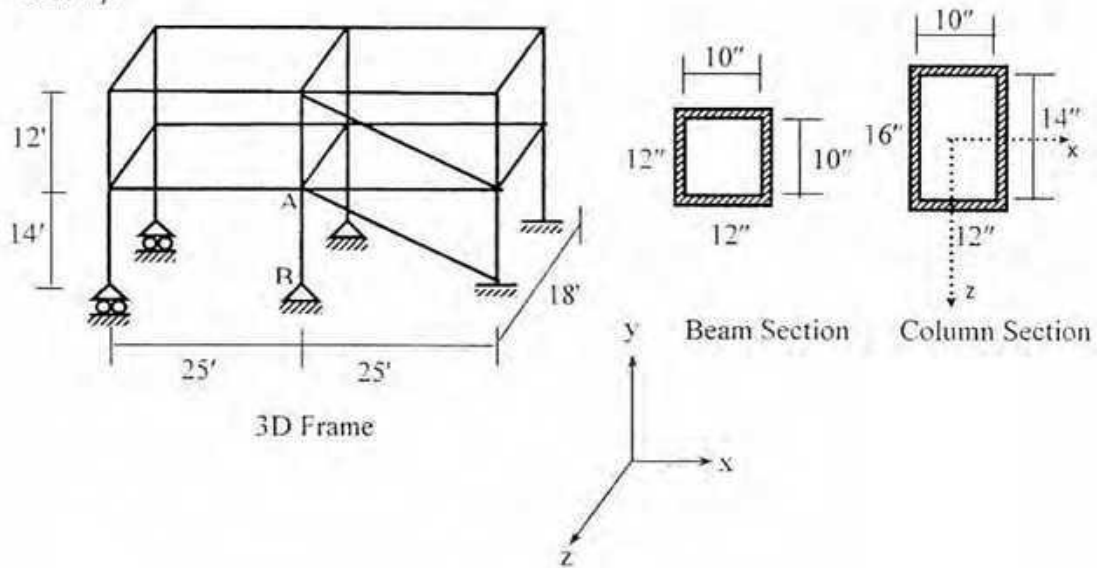

### List of Useful Formulae for CE 213

\* Torsional Rotation  $\phi_B - \phi_A = \int (T/J_{eq} G) dx$ , and  $= (TL/J_{eq} G)$ , if  $T$ ,  $J_{eq}$  and  $G$  are constants

Section	Torsional Shear Stress	$J_{eq}$
Circular	$\tau = Tc/J$	$\pi d^4/32$
Thin-walled	$\tau = T/(2A t)$	$4(A)^2/(ds/t)$
Rectangular	$\tau = T/(\alpha b t^2)$	$\beta b t^3$

b/t	1.0	1.5	2.0	3.0	6.0	10.0	$\alpha$
$\alpha$	0.208	0.231	0.246	0.267	0.299	0.312	0.333
$\beta$	0.141	0.196	0.229	0.263	0.299	0.312	0.333

\* Biaxial Bending Stress:  $\sigma_x(z, y) = M_z y/I_z - M_y z/I_y$

\* Combined Axial Stress and Biaxial Bending Stress:  $\sigma_z(x, y) = -P/A - M_x y/I_x - M_y x/I_y$

\* Corner points of the kern of a Rectangular Area are  $(b/6, 0)$ ,  $(0, h/6)$ ,  $(-b/6, 0)$ ,  $(0, -h/6)$

\* Maximum shear stress on a Helical spring:  $\tau_{max} = \tau_{direct} + \tau_{torsion} = P/A + Tr/J = P/A (1 + 2R/r)$

\* Stiffness of a Helical spring is  $k = Gd^4/(64R^3N)$

\*  $\sigma_{xx}' = (\sigma_{xx} + \sigma_{yy})/2 + \{(\sigma_{xx} - \sigma_{yy})/2\} \cos 2\theta + (\tau_{xy}) \sin 2\theta = (\sigma_{xx} + \sigma_{yy})/2 + \sqrt{\{(\sigma_{xx} - \sigma_{yy})/2\}^2 + (\tau_{xy})^2} \cos (2\theta - \alpha)$

$\tau_{xy}' = -\{(\sigma_{xx} - \sigma_{yy})/2\} \sin 2\theta + (\tau_{xy}) \cos 2\theta = \tau_{xy}' = -\sqrt{\{(\sigma_{xx} - \sigma_{yy})/2\}^2 + (\tau_{xy})^2} \sin (2\theta - \alpha)$

where  $\tan \alpha = 2 \tau_{xy}/(\sigma_{xx} - \sigma_{yy})$

\*  $\sigma_{xx(max)} = (\sigma_{xx} + \sigma_{yy})/2 + \sqrt{\{(\sigma_{xx} - \sigma_{yy})/2\}^2 + (\tau_{xy})^2}$ ; when  $\theta = \alpha/2$ ,  $\alpha/2 + 180^\circ$

$\sigma_{xx(min)} = (\sigma_{xx} + \sigma_{yy})/2 - \sqrt{\{(\sigma_{xx} - \sigma_{yy})/2\}^2 + (\tau_{xy})^2}$ ; when  $\theta = \alpha/2 \pm 90^\circ$

\*  $\tau_{xy(max)} = \sqrt{\{(\sigma_{xx} - \sigma_{yy})/2\}^2 + (\tau_{xy})^2}$ ; when  $\theta = \alpha/2 - 45^\circ$ ,  $\alpha/2 + 135^\circ$

$\tau_{xy(min)} = -\sqrt{\{(\sigma_{xx} - \sigma_{yy})/2\}^2 + (\tau_{xy})^2}$ ; when  $\theta = \alpha/2 + 45^\circ$ ,  $\alpha/2 - 135^\circ$

\* Mohr's Circle: Center  $(a, 0) = [(\sigma_{xx} + \sigma_{yy})/2, 0]$  and radius  $R = \sqrt{\{(\sigma_{xx} - \sigma_{yy})/2\}^2 + (\tau_{xy})^2}$

\*  $M(x) = EI \kappa \cong EI d^2v/dx^2$

\*  $w(x) \cong EI d^4v/dx^4$ ,  $V(x) = \int w(x) dx \cong EI d^3v/dx^3$ ,  $M(x) = \int V(x) dx \cong EI d^2v/dx^2$

$S(x) = \int M(x) dx \cong EI dv/dx \cong EI \theta(x)$ ,  $D(x) = \int S(x) dx \cong EI v(x)$

\* Singularity Functions for Common Loadings

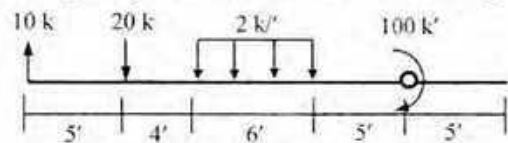

$$w(x) = 10\langle x-0 \rangle^{-1} - 20\langle x-5 \rangle^{-1} - 2\langle x-9 \rangle^0 + 2\langle x-15 \rangle^0 + 100\langle x-20 \rangle^{-2} + C_0\langle x-20 \rangle^{-3}$$

\* First Moment-Area Theorem:  $\theta_B - \theta_A = \int (M/EI) dx$

\* Second Moment-Area Theorem:  $(x_B - x_A) \theta_B - v_B + v_A = \int x (M/EI) dx$

\* Conjugate Beam Method

Original Beam	Free End	Fixed End	Hinge/Roller End	Internal Support	Internal Hinge
Conjugate Beam	Fixed End	Free End	Hinge/Roller End	Internal Hinge	Internal Support

\* Euler Buckling Load:  $P_{cr} = \pi^2 EI_{min}/(kL)^2$

\* Effect of Initial Imperfection:  $v(x) = v_0/[1 - P/P_{cr}] \sin(\pi x/L) \Rightarrow v(L/2) = v_0/[1 - P/P_{cr}]$

\* Effect of Load Eccentricity:  $\lambda^2 = P/EI \Rightarrow v(L/2) = e [\sec \lambda L/2 - 1] = e [\sec \{(\pi/2)\sqrt{(P/P_{cr})}\} - 1]$

\* Effect of Material Nonlinearity:  $P_{cr} = \pi^2 E_e I/L^2 \Rightarrow \sigma_{cr} = \pi^2 E_e/\eta^2$

\* Eccentric Loading with Elasto-plastic Material:

$v(L/2) = e [\sec \{(\pi/2)\sqrt{(P/P_{cr})}\} - 1]$  for the elastic range; and  $v(L/2) = M_p/P - e$  for the plastic range

\*  $k = 1.0$  for Hinge-Hinged Beam,  $0.7$  for Hinge-Fixed Beam,  $0.5$  for Fixed-Fixed Beam,  $2.0$  for Cantilever Beam

In general,  $k$  is obtained from  $\psi_A$  and  $\psi_B$  for braced and unbraced frames

\* AISC-ASD Method,  $\eta = L_e/r_{min}$ , and  $\eta_c = \pi\sqrt{(2E/f_y)}$

If  $\eta \leq \eta_c$ ,  $\sigma_{all} = f_y [1 - 0.5 (\eta/\eta_c)^2]/FS$ , where  $FS = [5/3 + 3/8 (\eta/\eta_c) - 1/8 (\eta/\eta_c)^3]$

If  $\eta > \eta_c$ ,  $\sigma_{all} = (\pi^2 E/\eta^2)/FS$ , where  $FS = \text{Factor of safety} = 23/12 = 1.92$

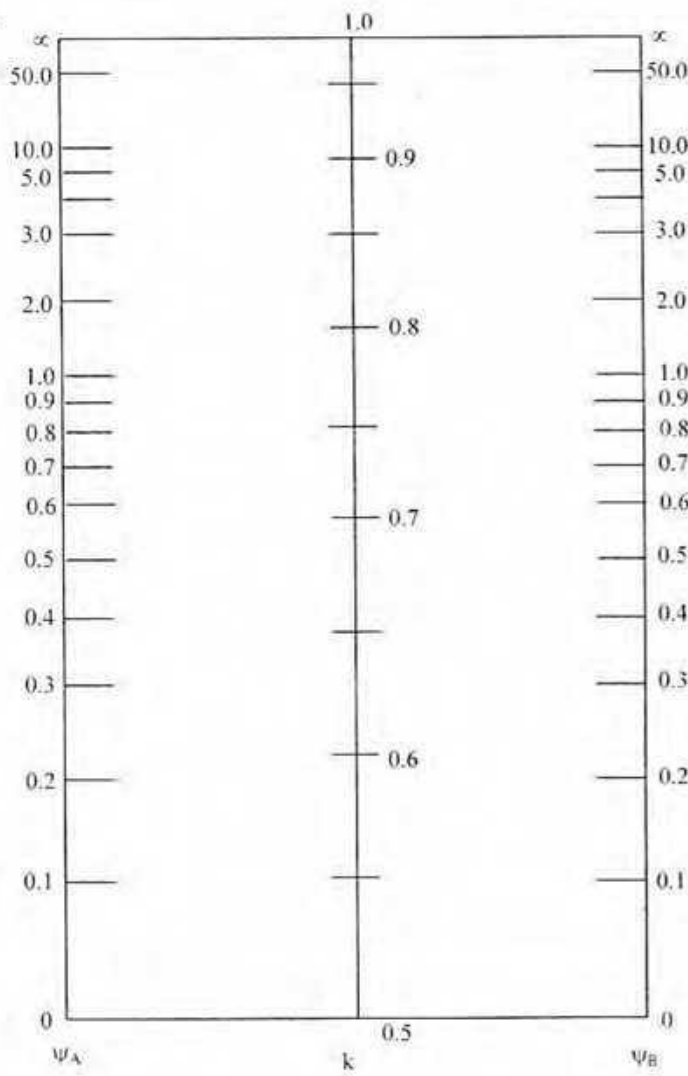

Braced Frames

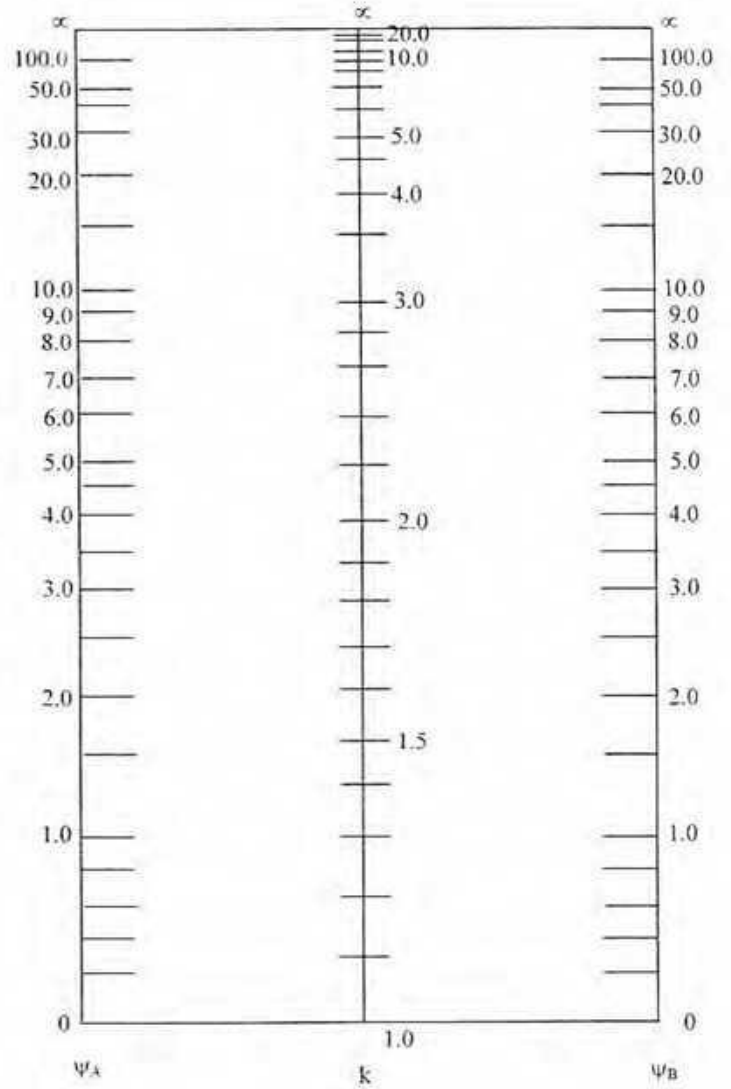

Unbraced Frames

**Alignment Charts for Effective Length Factors k**

$\psi$  = Ratio of  $\sum EI/L$  of compression members to  $\sum EI/L$  of flexural members in a plane at one end of a compression member.  
 $k$  = Effective length factor.

**The University of Asia Pacific**  
**Department of Civil Engineering**  
**Final Examination Fall 2009**  
**Program: B.Sc. Engineering Civil**

Course Title: Fluid Mechanics  
 Time : 3.0 hours

Course No : CE 221  
 Full Marks : 150

Credit: 3.00

Answer any 6 (SIX) questions. Figures in the right margin indicate full marks.

- 1 a. Differentiate between, (i) Lagrangian Method and Eulerian Method 6  
 (ii) Pathlines and Streamlines  
 (iii) Steady Flow and Unsteady Flow

- b. A space of 6.0 cm between two large plane surfaces is filled with glycerine as shown in Figure 1. Determine the force (F) required to drag vertically a very thin plate 0.90 m<sup>2</sup> in area between the plane surfaces at a constant speed of 1 m/s, if the plate is at a distance of 2.25 cm from one of the surfaces. Take dynamic viscosity 0.05 N-s/m<sup>2</sup> and weight of the plate 8 N. 9

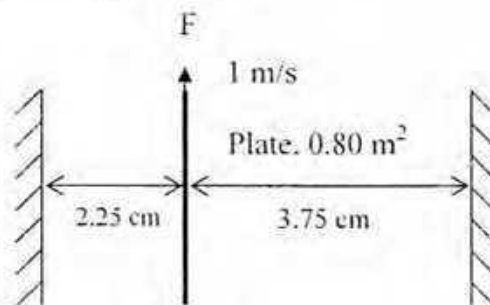

Figure 1

- c. Determine the capillary rise of water in a soil of average diameter 0.06 mm. Assume the average size of pores in soil to be one-fifth of the soil diameter. Take  $\sigma = 0.074$  N/m. 5
- d. A small drop of water at 20<sup>o</sup>c is in contact with air and has a diameter of 0.75 mm. If the pressure within the droplet is 0.60 kN/m<sup>2</sup> greater than the atmospheric pressure, calculate the value of the surface tension. 5
- 2 a. If the atmospheric pressure is 101.00 kN/m<sup>2</sup>. Calculate, 4  
 (i) gauge pressure of a point whose absolute pressure is 160 kN/m<sup>2</sup>, and,  
 (ii) vacuum pressure of a point whose absolute pressure is 60 kN/m<sup>2</sup>.
- b. What is a piezometer? Can a piezometer be used for measuring pressure in the pipe in which a gas is flowing? 4
- c. State Pascal's Law. 4

d. Determine the pressure at point A shown in Figure 2

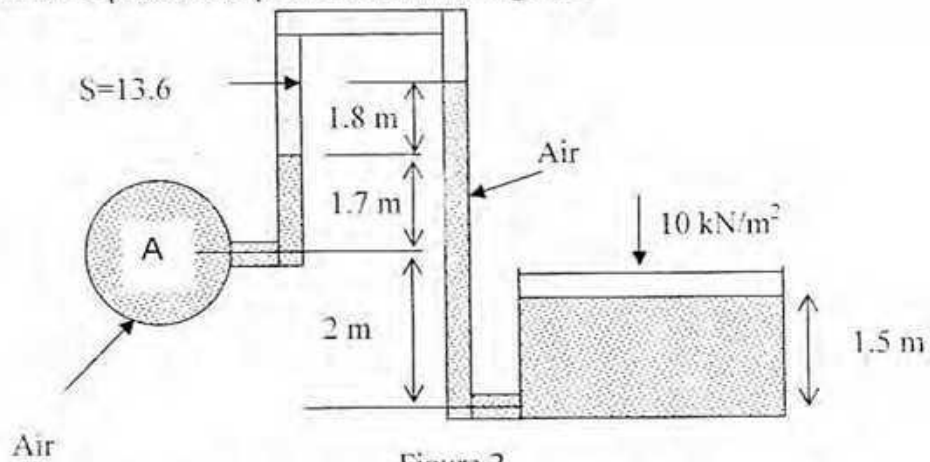

Figure 2

e. Determine gauge and absolute pressure reading of gauge A shown in Figure 3. ( Assume  $P_{atm} = 101.00 \text{ kN/m}^2$  )

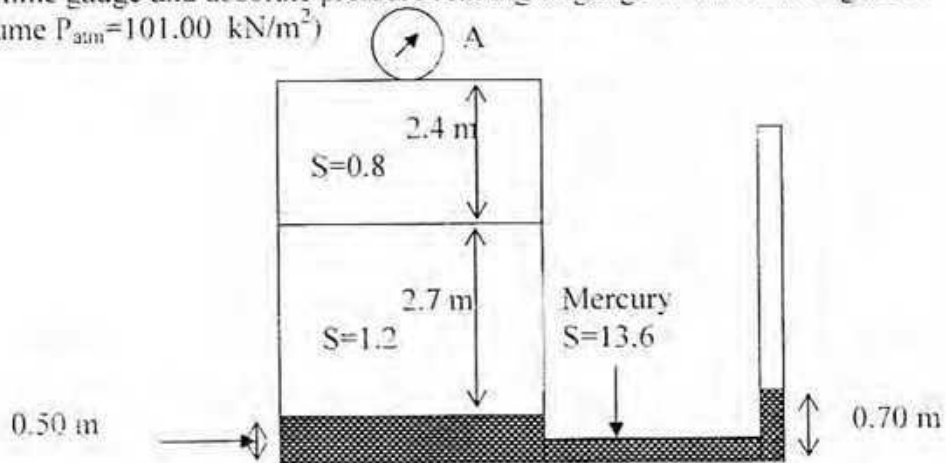

Figure 3

- 3 a. State Bernoulli equation and explain each term with neat figure. Mention clearly the assumptions made in the equation. 6
- b. What do you understand by the term 'centre of pressure'? 6
- c. Calculate the total pressure and the depth of the center of pressure on AB, BC and CD surface of a water container shown in Figure 4. The width of the container is 2.0 m 13

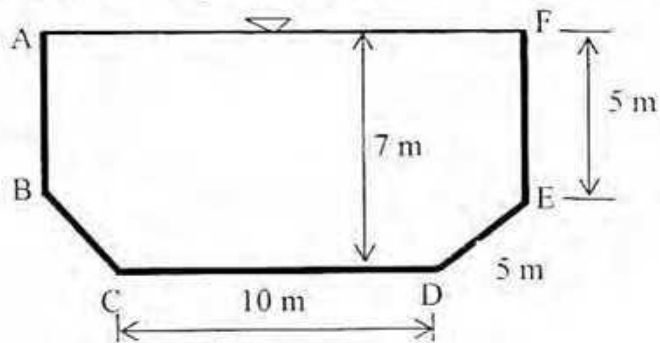

Figure 4

4. a. Two sides of a cylinder fitted with a piston are connected to the inlet and the throat of a horizontal venturimeter as shown in Figure 5. If the diameter at the inlet and the throat are 10 cm and 6 cm respectively and the velocity of water in the pipe is 5 m/s, calculate the force on the piston. The diameter of the piston is 2 cm. Ignore losses. 6

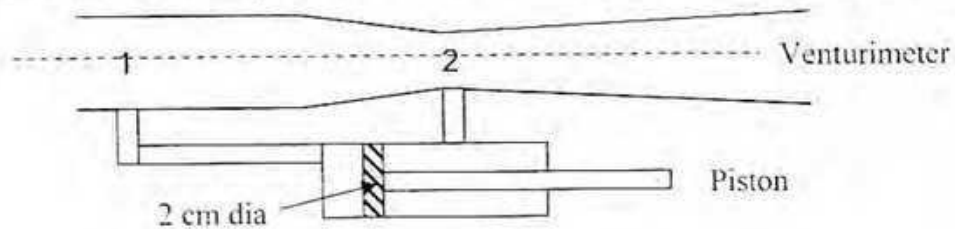

Figure 5

- b. Determine the horizontal and vertical forces acting on the curve surface CD on the cylinder in Figure 6. 6

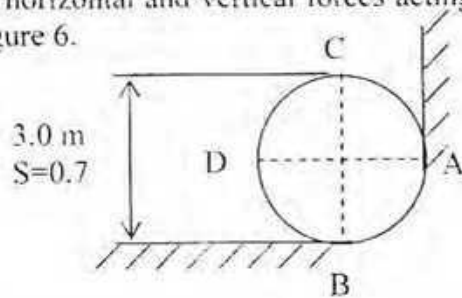

Figure 6

- c. Determine the horizontal and vertical forces acting on the curve surface DB on the cylinder in Figure 6. 7
- d. What is the net vertical force acting on the cylinder shown in Figure 6, if it weighs 25.0 kN. Neglect friction. 5
5. a. Define, (i) coefficient of contraction (ii) coefficient of velocity, and (iii) coefficient of discharge 6
- b. A circular orifice, 4.0 cm diameter, is made in the vertical wall of a tank. The jet falls vertically through 0.6 m while moving horizontally through a distance of 1.6 m. Calculate the coefficient of velocity if the head causing flow is 1.2 meters. If the discharge is  $1.70 \times 10^{-3} \text{ m}^3/\text{s}$ , Calculate  $C_c$  and  $C_d$ . 5
- c. Water enters in a  $120^\circ$  horizontal reducing pipe with a velocity of 5 m/sec and a pressure of  $80 \text{ kN/m}^2$  as shown in Figure 7. If the diameters at the entrance and exit sections are 25 cm and 15 cm respectively, calculate the components of the reaction e.g.  $R_x$  and  $R_y$  acting on the pipe. 14

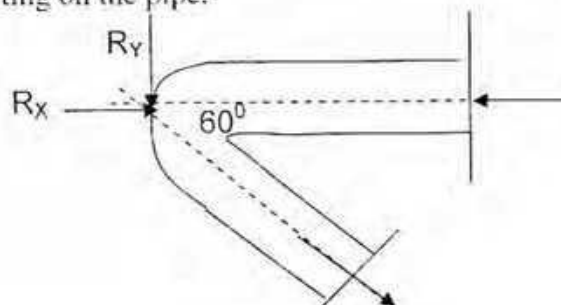

Figure 7

6. a. What is the difference between a weir and an orifice? How are the weirs classified? 2
- b. A rectangular channel 2.00 m wide has a rectangular weir at the end. If the length of the weir is 1.50 m, and its sill is 0.25 m from the bottom, find the discharge when the measured head over the crest is 0.50 m. Take  $C_d=0.60$ . 8
- c. Water is discharging through an external mouthpiece of  $40 \text{ cm}^2$  area, under a head of 4.0 m. Find the discharge through the mouthpiece. Take  $C_c=0.62$ . 4
- d. A sluice gate spans a channel 10 m wide. If the upstream depth is 4 m and the gate is raised by 0.4 m, determine the discharge. Take  $C_d=0.60$ . 6
7. a. What is Dimensional analysis? What are the different applications of the principles of Dimensional homogeneity in fluid mechanics? 6
- b. Check whether the following equations are dimensionally homogenous: 6
- a.  $Q = C_d a \sqrt{2gH}$       b.  $V = C \sqrt{RS}$       c.  $h_f = f \frac{L V^2}{D 2g}$
- c. Two reservoirs A & B shown in Figure 8 are connected by a pipe line consisting of two pipes, one of 10 cm diameter and length 8 m and the other of diameter 15 cm and 12 m length. If the difference of water levels in the two reservoirs is 5 m, calculate the discharge through the pipe. Take  $f=0.04$ . 10

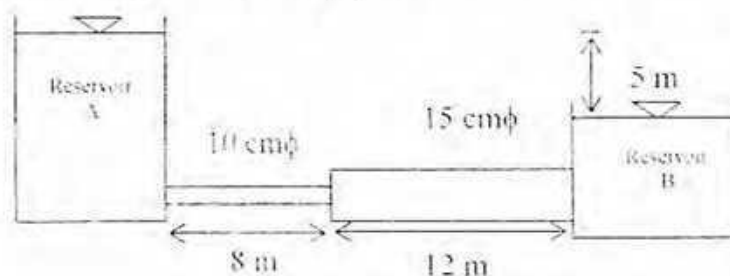

Figure 8

8. a. What do you understand by "minor losses" in pipes? Mention the places with neat sketches where minor losses may occur. 6
- b. A pipe of 1 m diameter connects two reservoirs having a difference of level of 8 m as shown in Figure 9. The total length of the pipe is 800 m and rises to a maximum height of 3 m above the level of water in the higher reservoir at a distance of 200 m from the entrance. Find the discharge in the pipe and the pressure at point A. Take  $f=0.04$ . 12

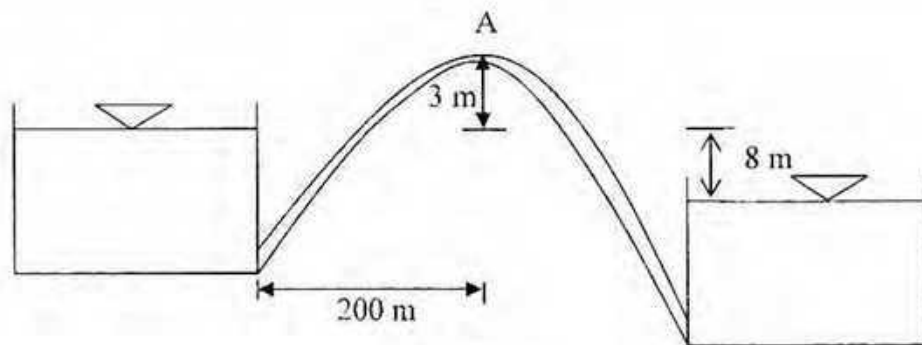

Figure 9

- c. Water is flowing through a pipe. The energy grade line is shown in Figure 10. Calculate flow of water through the pipe. Take  $f=0.04$ .

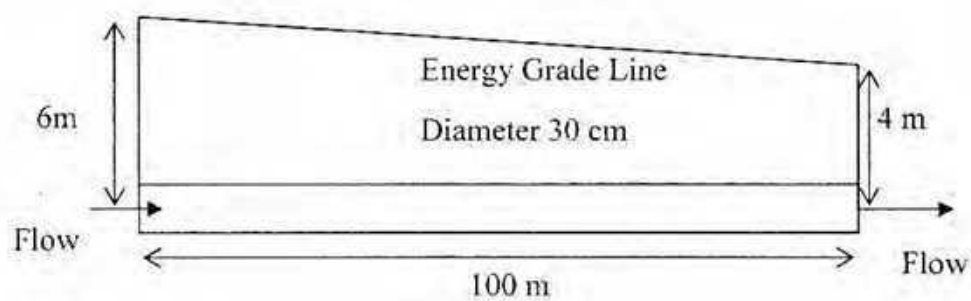

Figure 10

Formulae

$$\tau = \mu \frac{dv}{dy}$$

$$P = \gamma h$$

$$P_H = \gamma \bar{h} A_v$$

$$V_0 = \sqrt{2gh}$$

$$Q = 0.855a\sqrt{2gH}$$

$$H_a = \frac{V_a^2}{2g}$$

$$Q = CbH_s^{\frac{2}{3}}$$

$$h_f = f \frac{LV^2}{D 2g}$$

$$C = \frac{1}{n} R^{\frac{1}{6}}$$

$$P_i - P_o = \sigma \left( \frac{1}{R_1} + \frac{1}{R_2} \right) = \frac{2\sigma}{R} = \frac{4\sigma}{R} = \frac{\sigma}{R}$$

$$P = \lambda A \bar{h} \quad h' = \frac{I_G}{Ah} + \bar{h}$$

$$P_v = \gamma W = W \quad P = \sqrt{P_H^2 + P_v^2}$$

$$Q = C_d a \sqrt{2gH} \quad C_d = C_c \times C_v$$

$$Q = 0.707a\sqrt{2gH} \quad Q = \frac{2}{3} C_d b \sqrt{2gH^{\frac{3}{2}}}$$

$$Q = \frac{2}{3} C_d [b - 0.1n(H + H_a)] \sqrt{2g} \left[ (H + H_a)^{\frac{3}{2}} - H_a^{\frac{3}{2}} \right]$$

$$Q = C_d A \sqrt{2gy_1} \quad Q = \frac{8}{15} C_d \sqrt{2g} \tan \frac{\theta}{2} H^{\frac{5}{2}}$$

$$V = C \sqrt{RS} \quad C = \sqrt{\frac{8g}{f}}$$

$$H_L = \frac{(V_1 - V_2)^2}{2g} \quad H_L = K \frac{V^2}{2g}$$

$$h = \frac{4\sigma \cos \theta}{\gamma d}$$

$$h' = \frac{I_G \sin^2 \theta}{A \bar{h}} + \bar{h}$$

$$\sum M_o = \rho Q (\Delta V)$$

$$C_v = \sqrt{\frac{x^2}{4yH}}$$

$$b' = b - 0.1 \times n \times H$$

$$Q = 1.705 C_d b H^{\frac{3}{2}}$$

$$Q = CbH^n$$

$$V = \frac{1}{n} R^{\frac{2}{3}} \sqrt{S}$$

**The University of Asia Pacific**  
**Department of Civil Engineering**  
**Final Examination Fall 2009**  
**Program: B. Sc. Engineering (Civil)**

Course Title: Structural Engineering II  
 Time: 3 hours

Credit Hours: 3.0

Course Code: CE 313  
 Full Marks: 100 (= 10 × 10)

[Answer any 10 (ten) of the following 14 questions]

1. For the frame loaded as shown below, calculate the value of the applied forces  $P$  if the
- maximum column bending moment in the frame is 100 kN-m (use the *Portal Method*),
  - maximum column axial force in the frame is 50 kN (use the *Cantilever Method*, assuming columns  $bf$  and  $cg$  to have twice the cross-sectional areas of the other columns).

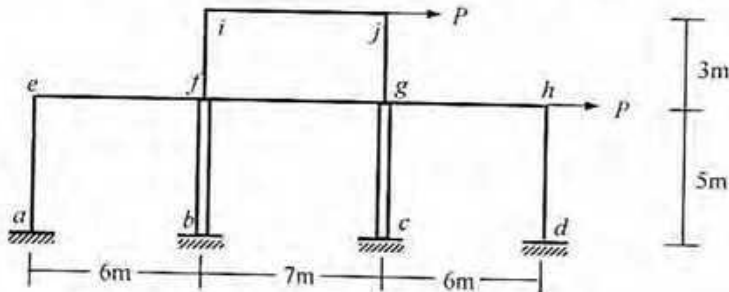

2. (i) In the two-storied frame shown below, the maximum column axial force is 100 kips. Use the ACI coefficients to calculate the distributed load  $w$  (k/ft) and draw the BMD of beam  $def$ .

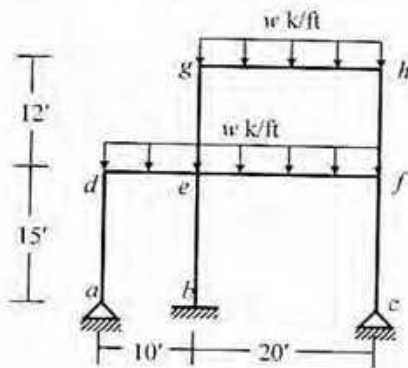

Fig. for Question 2(i)

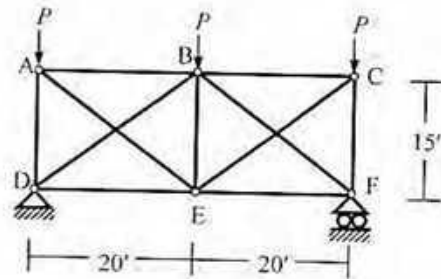
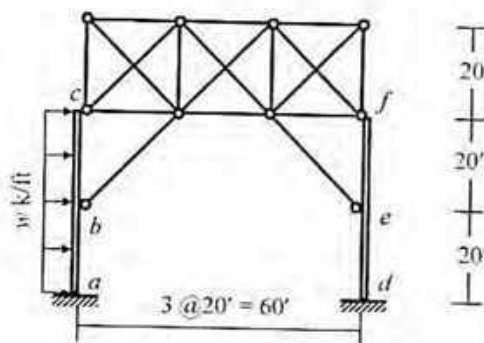
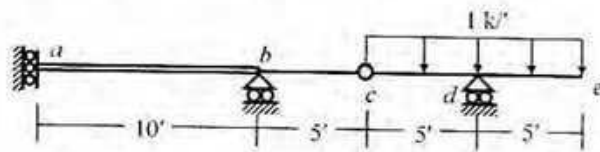

Fig. for Question 2(ii)

- (ii) In the truss ABCDEF shown above, the maximum tensile force in the diagonal members is 100 kips. Calculate the applied forces  $P$ , if diagonal members take equal share of the sectional shear force.
3. The maximum bending moment in column  $def$  of the Bridge Portal  $abcdef$  shown below is 100 k-ft. Use the Portal Method to calculate the applied load  $w$  (k/ft) and draw the SFD and BMD of column  $abc$ .



4. Use the Unit Load Method (considering flexural and shear deformations) to calculate the rotation on the left and right of  $c$  of the beam  $abcde$  loaded as shown below  
 [Given:  $EI_{ab} = 40 \times 10^3 \text{ k-ft}^2$ ,  $EI_{cde} = 20 \times 10^3 \text{ k-ft}^2$ ,  $GA^* = \text{constant} = 120 \times 10^3 \text{ k}$ ].



$a$  is a Guided Roller Support  
 $e$  is an Internal Hinge

5. Use the Unit Load Method (considering flexural and axial deformations) to calculate the vertical deflection at joint  $c$  of the frame  $abcde$  loaded as shown below  
 [Given:  $EI = \text{constant} = 40 \times 10^3 \text{ kN-m}^2$ ,  $EA = \text{constant} = 4 \times 10^6 \text{ kN}$ ].

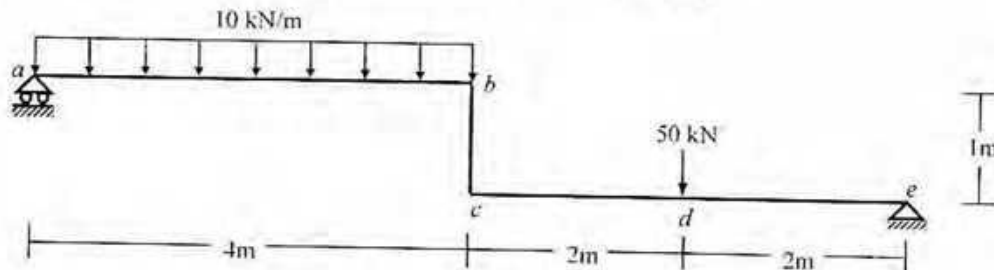

6. Use the Flexibility Method to calculate the forces in all the members of the truss  $abcdef$  shown below, if support  $e$  settles 0.010-m downward [Given:  $EA/L = \text{constant} = 15000 \text{ kN/m}$ ].

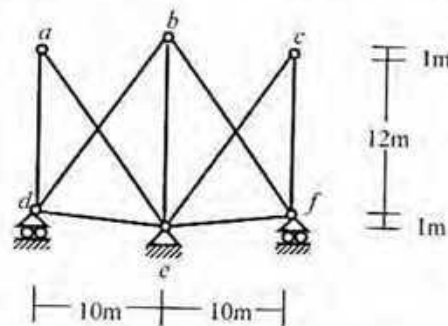

7. Use the Flexibility Method (considering flexural and shear deformations) to calculate the reaction at support  $D$  of the beam  $ABCDEF$  shown below, if in addition to the applied load, support  $D$  settles 0.10' downward [Given:  $EI_{ABCDE} = 20 \times 10^3 \text{ k-ft}^2$ ,  $EI_{EF} = 40 \times 10^3 \text{ k-ft}^2$ ,  $GA^* = \text{constant} = 120 \times 10^3 \text{ k}$ ].

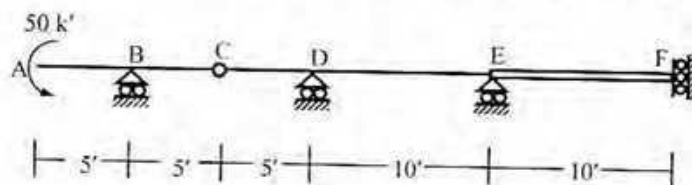

$C$  is an Internal Hinge  
 $F$  is a Guided Roller Support

8. Use the Moment Distribution Method to calculate the joint moments and draw the bending moment diagram of beam  $ABCDEF$  described in Question 7 (including the applied load and support settlement) [Use symmetry to extend the structure about 'F'].
9. For the beam  $ABCDEF$  shown in Question 7, draw the qualitative influence lines of support reactions  $R_B$ ,  $R_E$ , shear forces  $V_{D(Right)}$ ,  $V_{E(Left)}$  and bending moments  $M_D$ ,  $M_E$ ,  $M_F$ .
10. For the beam  $ABCDEF$  shown in Question 7, calculate the maximum value of  $R_D$  (reaction at support  $D$ ) for a uniformly distributed dead load of 1 k/ft, a moving uniformly distributed load of 0.5 k/ft and a moving concentrated load of 5 k.

11. Use the Flexibility Method (considering flexural and axial deformations) to calculate the vertical reaction at support *e* of the frame shown below, if in addition to the applied loads, support *e* moves 0.010-m rightward [Given:  $EI = \text{constant} = 40 \times 10^3 \text{ kN-m}^2$ ,  $EA = \text{constant} = 4 \times 10^6 \text{ kN}$ ].

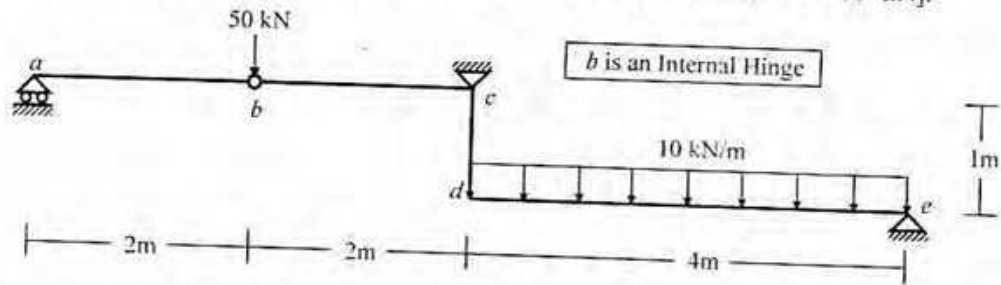

12. Use the Moment Distribution Method to calculate the joint moments and draw the bending moment diagram of the frame *abcde* described in Question 11 (including applied loads and support settlement).

13. Determine the size of the flexibility matrix for the structures shown below. Also convert them to statically determinate structures to be used in 'Case 0' of the Flexibility Method.

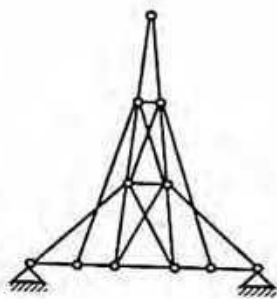

2D Truss

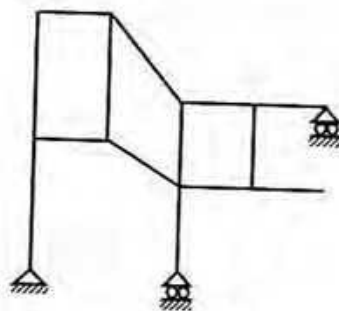

2D Frame

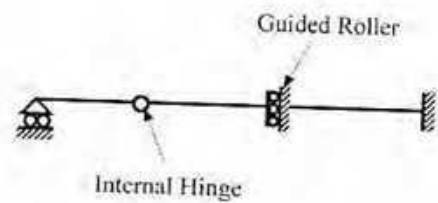

Beam

14. (i) Explain why it is often useful to perform approximate analysis of statically indeterminate structures.  
 (ii) Explain why the unit load method is often used in the structural analysis by Flexibility Method.  
 (iii) Mention two basic characteristics of the Flexibility Matrix of a structure.  
 (iv) Mention the main advantage and limitation of the Moment Distribution Method.  
 (v) Comment on the applicability of 'qualitative' and 'quantitative' influence lines.

**The University of Asia Pacific**  
**Department of Civil Engineering**  
**Final Examination Fall 2009**  
**Program: B. Sc. Engineering (Civil)**

Course Title: Design of Concrete Structures I  
Time: 3 Hours

Course Code: CE 315  
Full Marks: 150

There are EIGHT questions. Answer SIX Questions including Question No. 1 and 2. Question No. 1 and Question No. 2 are Compulsory.

- 1(a) Compare WSD and USD. (3)
- 1(b) "Tensile yielding of steel is preferable to compression failure of concrete"- why? (3)
- 1(c) "Deformed bars have more bond stress compared to plain bars" – Explain. (3)
- 1(d) "The bond strength of top bars is lower than the same of bottom bars of a beam" – why? (3)
- 1(e) Compare doubly reinforced and singly reinforced concrete beams. (3)
- 1(f) Derive the following equation for the spacing of shear reinforcement: (10)

$$S = \frac{A_v f_v d}{V - V_c}$$

The symbols carry their usual meaning.

- 2(a) Design the following beam for moment by USD. Given: LL = 1 k/ft, DL = 1 k/ft (excluding self-weight), Width of the beam = 12 in.,  $f_y = 40,000$  psi,  $f_c = 3500$  psi. (17)

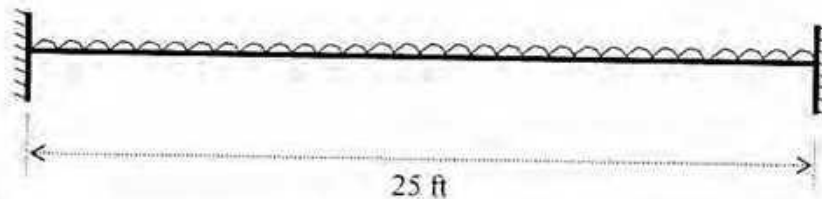

- 2(b) Draw the schematic sketch of the flexural reinforcement for the following structures: (8)

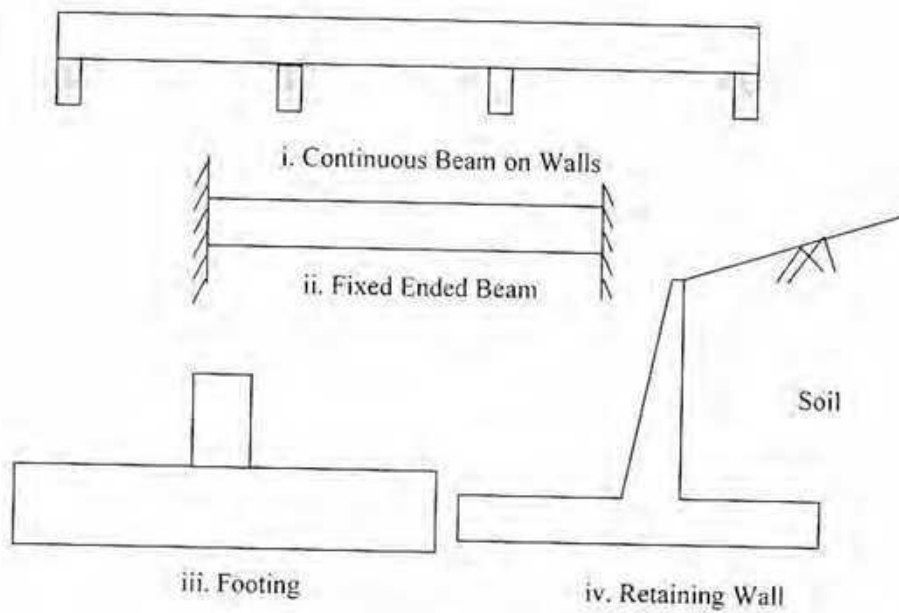

- 3(a) Design the shear reinforcement for the simply supported beam shown below by WSD. Given: LL = 1 k/ft, DL = 1.2 k/ft,  $f_v = 20,000$  psi, and  $f_c' = 3500$  psi. Draw the layout of the stirrups in a neat sketch. (19)

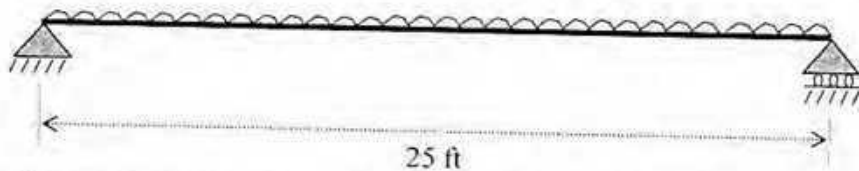

- 3(b) Draw the strain and stress variation across the section of a beam due to the pure flexure for the following conditions: (6)
- I. Elastic stress-strain behavior, Very low strain level, tensile stress of concrete is less than the tensile strength of concrete
  - II. Tensile stress is higher than the tensile strength of concrete, elastic stress-strain behavior of concrete, stress in steel is less than the yield strength of steel
  - III. Tensile stress is higher than the tensile strength of concrete, inelastic stress-strain behavior of concrete, stress in steel is equal to the yield strength of steel

- 4(a) Derive the following equation for development length of steel bar in concrete (8)

$$L_d = \frac{A_s f_s}{u_u \sum o}$$

The symbols carry their usual meaning.

- 4(b) Calculate the design positive moment capacity of the following beam (17) section. Use USD. Given:  $f_y = 50,000$  psi,  $f'_c = 4000$  psi.

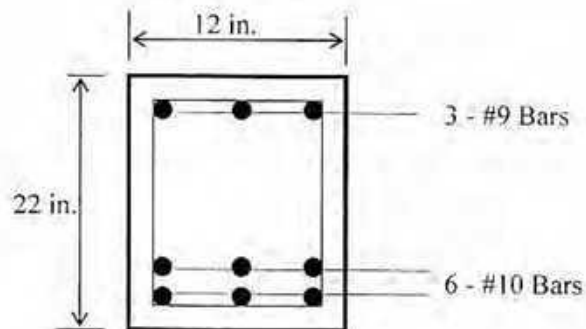

- 5(a) Refer to the following beam and beam section: (20)

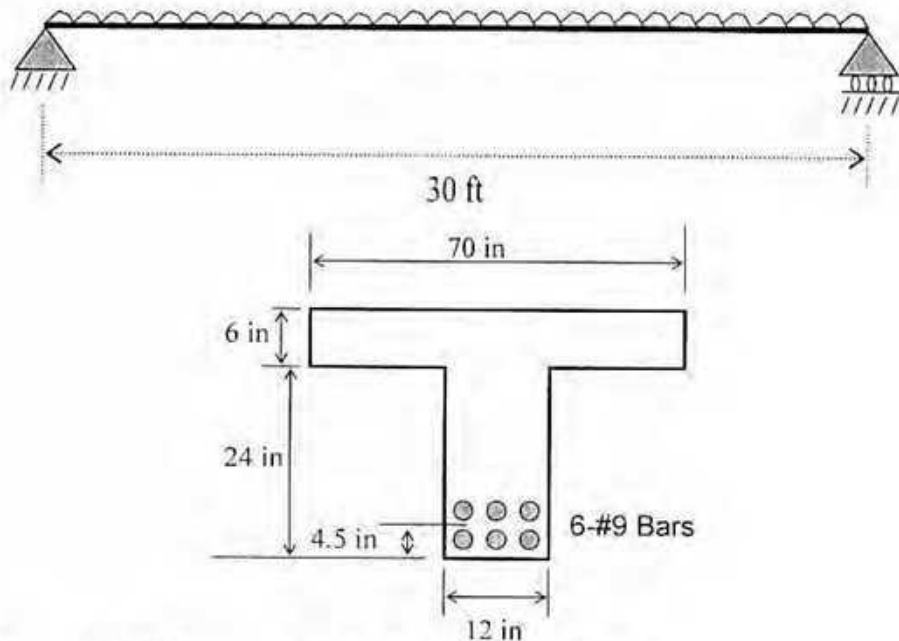

Given:  $f_y = 60,000$  psi,  $f_s = 20,000$  psi,  $f'_c = 4000$  psi.

Calculate the followings:

- (i) Area of the uncracked transformed section
- (ii) Distance of the neutral axis from the outermost bottom fiber of the uncracked transformed section
- (iii) Moment of inertia of the uncracked transformed section about the neutral axis
- (iv) Minimum cracking moment
- (v) Minimum uniformly distributed load (excluding self weight) necessary for cracking of concrete.
- (vi) Maximum compressive stress in concrete when the beam is cracked.

5(b) Write the specification of ACI for hooks. (5)

6 The layout of the slab and beams of a floor is given below. The slab was made monolithically with the beams. Calculate the steel area necessary for the beam located at the center. An architect decides the dimensions as shown. Use USD. Given:  $f_y = 40,000$  psi,  $f_c' = 3500$  psi, LL = 2.4 k/ft. (25)

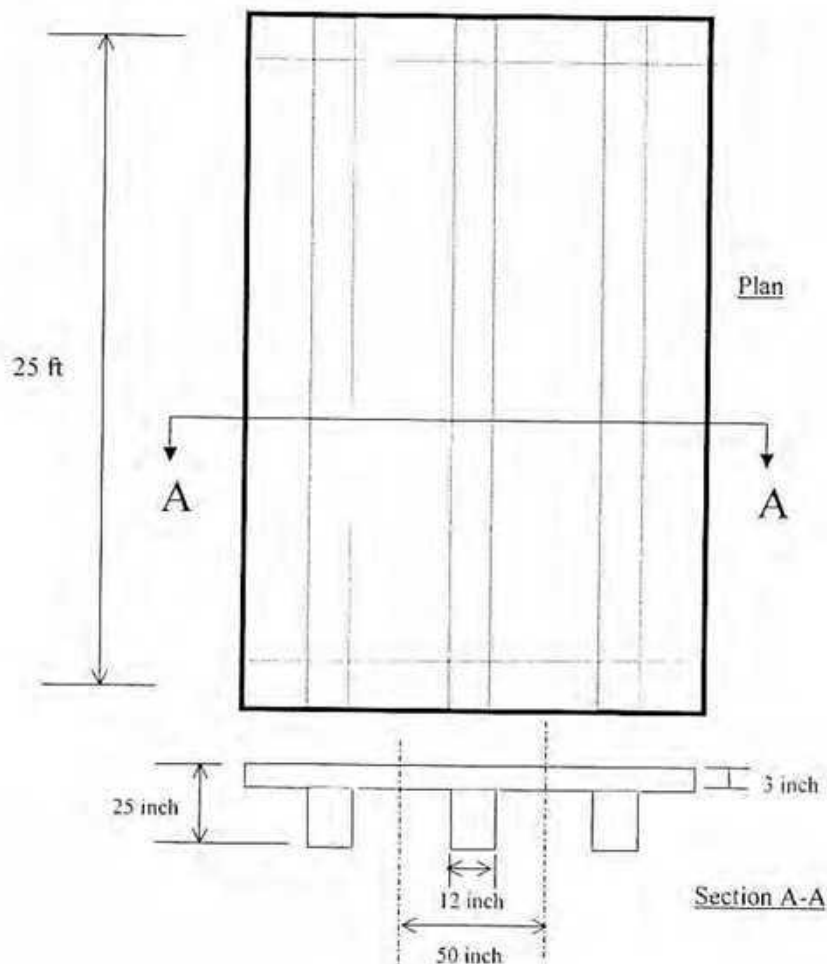

7(a) Define balanced steel ratio. Derive the following equation for balanced steel ratio: (10)

$$\rho_b = \alpha \frac{0.003}{\frac{f_y}{E_s} + 0.003} \frac{f_c'}{f_y}$$

The symbols carry their usual meaning.

7(b) Due to the architectural requirement the section of a beam is limited to 13 inch by 24 inch. For the design working moment of 2700 kip-inch, determine the required steel area. Use WSD. Given:  $f_s = 20,000$  psi,  $f_c' = 4000$  psi. (15)

8(a) What are the critical sections to be checked for bond stress? The working design shear at the face of a support is 35.5 kips. The beam has 4 - #10 bars (at top) at the face of the support. Effective depth of the beam is 23.5 inch. Check the bond stress at the face of the support using USD. Assume  $f_c' = 3000$  psi. (5)

8(b) Design the following simply supported slab by WSD. (20)

Given:  $f_s = 24,000$  psi,  $f_c' = 3500$  psi, LL = 80 psf, Floor Finish = 25 psf, Partition Wall = 40 psf.

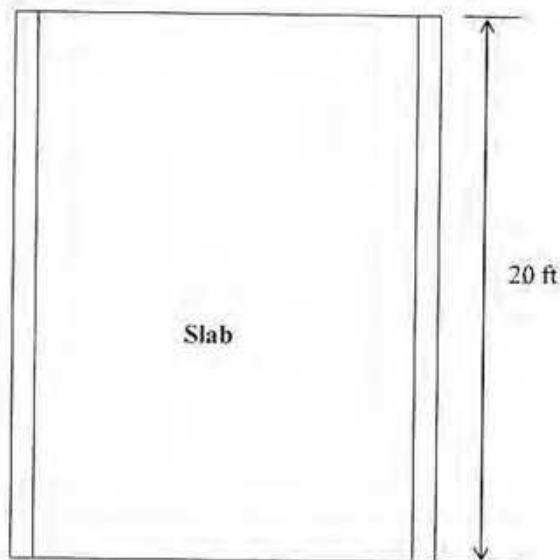

Plan

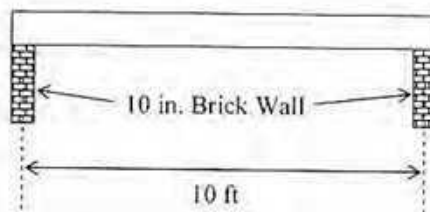

Section

Draw the layout of the reinforcements in neat sketches in a plan and two sections.

**The University of Asia Pacific**  
**Department of Civil Engineering**  
**Final Examination Fall 2009**  
**Program: B. Sc. Engineering (Civil)**

Course Title: Design of Concrete Structures II  
Time: 3 Hours

Course Code: CE 317  
Full Marks: 150

There are **EIGHT** Questions. Answer any **SIX** Questions.

1. Refer to the following slab system of a two-storied building: (25)

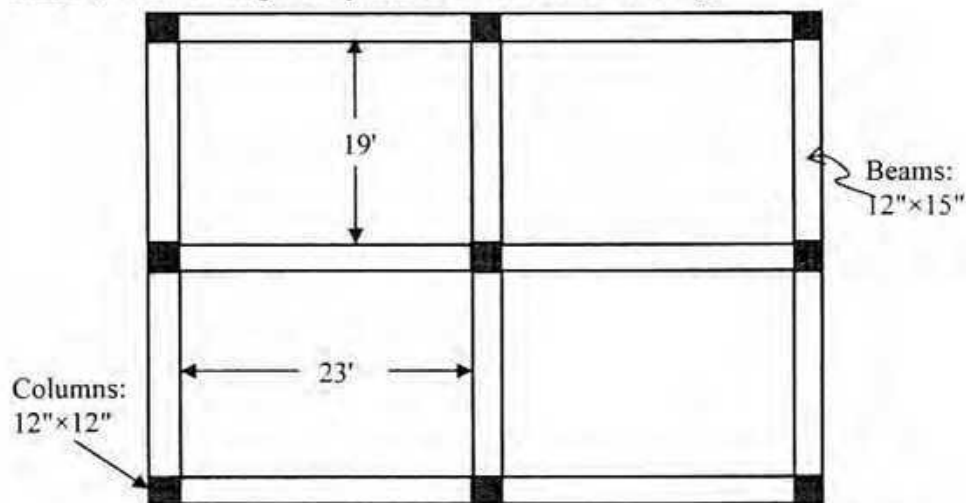

LL = 60 psf, partition wall = 30 psf, floor finish = 20 psf,  $f_c = 3,000$  psi,  $f_y = 50,000$  psi,  $f_s = 20,000$  psi,  $j = 0.874$ ,  $R = 223$  psi

Design the slab by WSD. Follow the steps mentioned below:

- (i) Calculation for minimum slab thickness
- (ii) Determination of moment coefficients and calculation for design moments
- (iii) Check for slab thickness to avoid compression failure of concrete
- (iv) Calculation for flexural reinforcements
- (v) Check for temperature and shrinkage reinforcements
- (vi) Neat sketches of reinforcements (including corner reinforcement) (plan and one section)

Tables for moment coefficients are attached.

- 2.(a) A building is to be designed as a flat plate structure. The columns are 24" x 24" in size and are on 24' x 26' grid. The building will have no beams on column lines. Other design conditions and material properties are given below: (20)

FF=20 psf, Random wall load = 30 psf and LL=80 psf,  $f_y = 60,000$  psi,  $f_c = 3000$  psi.

Design an interior panel by USD.

Follow the steps mentioned below:

- (i) Calculation for minimum slab thickness
- (ii) Check for punching shear – around interior column
- (iii) Calculation for design moments
- (iv) Check for slab thickness – moment consideration
- (v) Calculation for flexural reinforcements (in long direction only)
- (vi) Neat sketches for reinforcements (in long direction only)

- (b) For the flat plate structure, when the punching resistance of slab-column connection is found inadequate, describe in brief what are the possible ways to increase the punching resistance? (05)

- 3.(a) Construct the interaction curve by USD for the column section shown below with at least five points including those corresponding to pure bending, pure axial load and balanced failure [ Given:  $f_c = 3$  ksi,  $f_y = 60$  ksi,  $E_s = 29000$  ksi]. Assume bending about Y-Y axis. (18)

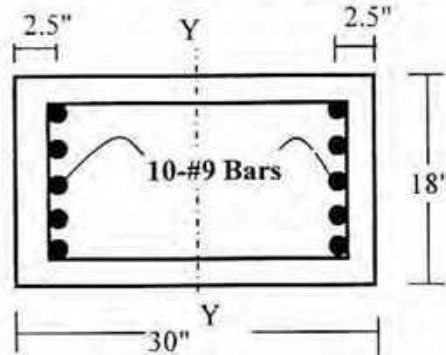

- (b) Why are ties provided in column? Draw the tie arrangements of the following column sections as per ACI Code. (all bars #9 i.e. 1-1/8" dia) (2+5)

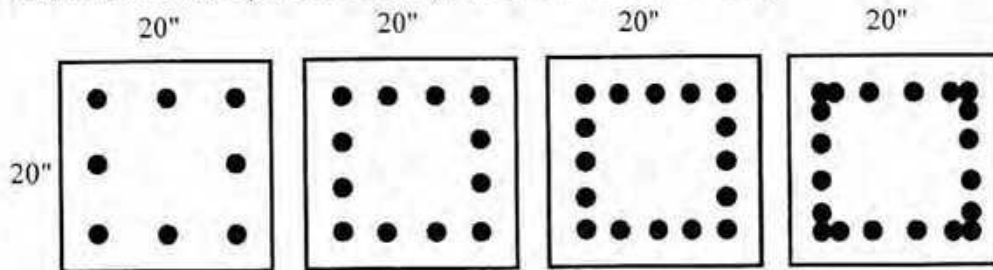

(i) 8 bars

(ii) 12 bars

(iii) 16 bars

(iv) 20 bars

4. (a) Design a tied column supporting a DL=350 k and LL=250 k assuming a moderate % of steel by WSD. Given:  $f_c = 3$  ksi,  $f_y = 50$  ksi,  $f_s = 20$  ksi. (05)
- (b) Keeping the same cross-section as in 4(a) design the same column by USD. (05)
- (c) Keeping the actual % of steel as in 4(a) design the column by USD. (05)
- (d) Give your comments on the above designs. (03)
- (e) For the same loads as in 4(a), design a spirally reinforced column (spirals also) by WSD. (07)

5. An isolated footing is planned under a column with the following data: (25)

Column size = 18 in by 18 in

DL = 225 kips, LL = 175 kips,  $q_{all} = 4$  ksf,  $f'_c = 3$  ksi,  $f_y = 50$  ksi,  $f_s = 20$  ksi,

$j = 0.874$ ,  $R = 223$  psi

Due to the site restriction, the maximum footing dimension in one direction is to be limited at 8 ft.

Design the footing by WSD. Follow the steps mentioned below:

- (i) Calculation for bearing area (i.e. size of the footing)
  - (ii) Check for punching shear
  - (iii) Check for beam shear
  - (iv) Calculation for design moment and check for footing thickness
  - (v) Calculation for reinforcements
  - (vi) Neat sketches of reinforcements (plan and sections)
- 6.(a) A cross section of a cantilever type retaining wall with 4 (four) possible locations through which the resultant may pass (either A, B, C or D) is shown in the following figure. Draw the qualitative soil pressure diagrams for the footing for each case. (10)

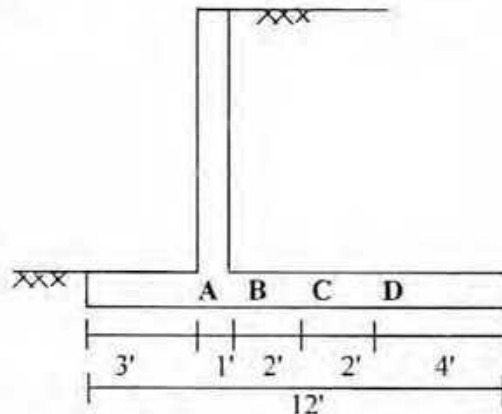

- (b) The plan of a pile cap with 16 nos. 18" dia piles and the column (24"x24") is shown in the following figure. Net reaction of a single pile is 60k. The total thickness of the pile cap is 48" having average  $d = 39$ " (15)

i) Calculate the critical punching and beam shear stress.

ii) Calculate the design moments

iii) Comment on the adequacy of the thickness

[Given:  $f'_c = 3$  ksi,  $f_y = 50$  ksi]

Use WSD method.

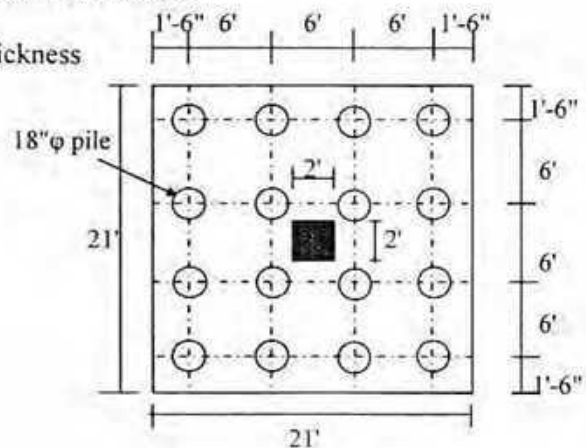

- 8.(a) A pretensioned concrete beam has a prestress of 340 kips in steel at transfer which eventually reduces to 290 kips due to losses. The beam carries two live loads of 10 k each at the third points on a simply supported span of 36 ft. Compute the extreme fibre stresses in midspan due to loads including self weight of beam for the following conditions: (10)

- i) at initial condition with full prestress and no live load
- ii) at working condition with effective prestress and full live loads.

Compare stresses with ACI allowable stresses.

Given:  $n=7, f_c'=5 \text{ ksi}, f_{ct}'=5 \text{ ksi}, f_{pe}=250 \text{ ksi}$   
self wt. of beam = 0.3 k/ft

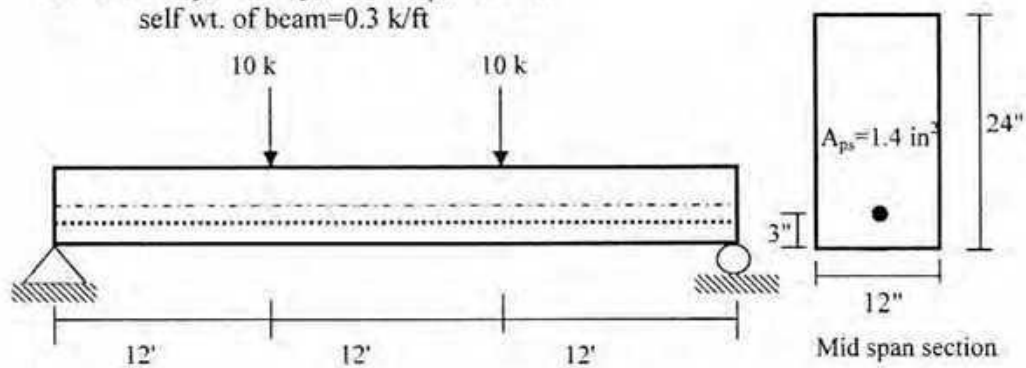

- (b) For the beam defined as in Question 8(a), calculate ultimate moment capacity and ultimate load (in UDL) that can be superimposed on the beam. [07]

[Given:  $f_{ps} = f_{pu} [1 - 0.5 \rho_p f_{pu} / f_c']$ ]

- (c) Make a preliminary design for an I-section of a prestressed concrete beam to resist a total moment of 355 k-ft of which girder moment  $M_G = 55 \text{ k-ft}$ . Assume depth,  $h = 36"$ ,  $f_{sc} = 125 \text{ ksi}$ ,  $f_c = 145 \text{ ksi}$  and  $f_t = -1.7 \text{ ksi}$ . [08]

6.5.2 Scope and Limitations

6.5.2.1 The provisions of this section may be used as alternative to those of Sec 6.4 for two-way slabs supported on all four edges by walls, steel beams or monolithic concrete beams having a total depth not less than 3 times the slab thickness.

6.5.2.2 Panels shall be rectangular with a ratio of longer to shorter span centre to centre of supports not greater than 2.

6.5.2.3 The value of  $(\alpha_1 \ell_2 / \ell_1)$  shall be greater than or equal to 1.

6.5.3 Analysis by the Coefficient Method

6.5.3.1 The negative moments and dead load and live load positive moments in the two directions shall be computed from Tables 6.6.11, 6.6.12 and 6.6.13 respectively. Shear in the slab and loads on the supporting beams shall be computed from Table 6.6.14.

6.5.4 Shear on Supporting Beam

The shear requirements provided in Sec 6.4.7.6 shall be satisfied.

6.5.5 Deflection

Thickness of slabs supported on walls or stiff beams on all sides shall satisfy the requirements of Sec 6.4.3.1 (b) and (c).

Table 6.6.11  
Coefficients for Negative Moments in Slabs †

$$M_{a,neg} = C_{a,neg} w \ell_a^2$$

$$M_{b,neg} = C_{b,neg} w \ell_b^2$$

where  $w$  = total uniform dead plus live load per unit area

Ratio $m = \frac{\ell_a}{\ell_b}$	Case 1	Case 2	Case 3	Case 4	Case 5	Case 6	Case 7	Case 8	Case 9
1.00		0.045		0.050	0.075	0.071		0.033	0.061
		0.045	0.076	0.050			0.071	0.061	0.033
0.95		0.050		0.055	0.079	0.075		0.038	0.065
		0.041	0.072	0.045			0.067	0.056	0.029
0.90		0.055		0.060	0.080	0.079		0.043	0.068
		0.037	0.070	0.040			0.062	0.052	0.025
0.85		0.060		0.066	0.082	0.083		0.049	0.072
		0.031	0.065	0.034			0.057	0.046	0.021
0.80		0.065		0.071	0.083	0.086		0.055	0.075
		0.027	0.061	0.029			0.051	0.041	0.017
0.75		0.069		0.076	0.085	0.088		0.061	0.078
		0.022	0.056	0.024			0.044	0.036	0.014
0.70		0.074		0.081	0.086	0.091		0.068	0.081
		0.017	0.050	0.019			0.038	0.029	0.011
0.65		0.077		0.085	0.087	0.093		0.074	0.083
		0.014	0.043	0.015			0.031	0.024	0.008
0.60		0.081		0.089	0.088	0.095		0.080	0.085
		0.010	0.035	0.011			0.024	0.018	0.006
0.55		0.084		0.092	0.089	0.096		0.085	0.086
		0.007	0.028	0.008			0.019	0.014	0.005
0.50		0.086		0.094	0.090	0.097		0.089	0.088
		0.006	0.022	0.006			0.014	0.010	0.003

† A crosshatched edge indicates that the slab continues across, or is fixed at the support; an unmarked edge indicates a support at which torsional resistance is negligible.

Table 6.6.13  
Coefficients for Live Load Positive Moments in Slabs †

$$M_{a, pos, ll} = C_{a, ll} w \ell_a^2$$

$$M_{b, pos, ll} = C_{b, ll} w \ell_b^2 \quad \text{where } w = \text{uniform live load per unit area}$$

Ratio $m = \frac{\ell_a}{\ell_b}$	Case 1	Case 2	Case 3	Case 4	Case 5	Case 6	Case 7	Case 8	Case 9	
1.00	$C_{a, ll}$	0.036	0.027	0.027	0.032	0.032	0.035	0.032	0.028	0.030
	$C_{b, ll}$	0.036	0.027	0.032	0.032	0.027	0.032	0.035	0.030	0.028
0.95	$C_{a, ll}$	0.040	0.030	0.031	0.035	0.034	0.038	0.036	0.031	0.032
	$C_{b, ll}$	0.033	0.025	0.029	0.029	0.024	0.029	0.032	0.027	0.025
0.90	$C_{a, ll}$	0.045	0.034	0.035	0.039	0.037	0.042	0.040	0.035	0.036
	$C_{b, ll}$	0.029	0.022	0.027	0.026	0.021	0.025	0.029	0.024	0.022
0.85	$C_{a, ll}$	0.050	0.037	0.040	0.043	0.041	0.046	0.045	0.040	0.039
	$C_{b, ll}$	0.026	0.019	0.024	0.023	0.019	0.022	0.026	0.022	0.020
0.80	$C_{a, ll}$	0.056	0.041	0.045	0.048	0.044	0.051	0.051	0.044	0.042
	$C_{b, ll}$	0.023	0.017	0.022	0.020	0.016	0.019	0.023	0.019	0.017
0.75	$C_{a, ll}$	0.061	0.045	0.051	0.052	0.047	0.055	0.056	0.049	0.046
	$C_{b, ll}$	0.019	0.014	0.019	0.016	0.013	0.016	0.020	0.016	0.013
0.70	$C_{a, ll}$	0.068	0.049	0.057	0.057	0.051	0.060	0.063	0.054	0.050
	$C_{b, ll}$	0.016	0.012	0.016	0.014	0.011	0.013	0.017	0.014	0.011
0.65	$C_{a, ll}$	0.074	0.053	0.064	0.062	0.055	0.064	0.070	0.059	0.054
	$C_{b, ll}$	0.013	0.010	0.014	0.011	0.009	0.010	0.014	0.011	0.009
0.60	$C_{a, ll}$	0.081	0.058	0.071	0.067	0.059	0.068	0.077	0.065	0.059
	$C_{b, ll}$	0.010	0.007	0.011	0.009	0.007	0.008	0.011	0.009	0.007
0.55	$C_{a, ll}$	0.088	0.062	0.080	0.072	0.063	0.073	0.085	0.070	0.063
	$C_{b, ll}$	0.008	0.006	0.009	0.007	0.005	0.006	0.009	0.007	0.006
0.50	$C_{a, ll}$	0.095	0.066	0.088	0.077	0.067	0.078	0.092	0.076	0.067
	$C_{b, ll}$	0.006	0.004	0.007	0.005	0.004	0.005	0.007	0.005	0.004

† A crosshatched edge indicates that the slab continues across, or is fixed at the support; an unmarked edge indicates a support at which torsional resistance is negligible.

Annexure-3

Table 6.6.12  
Coefficients for Dead Load Positive Moments in Slabs †

$$M_{a, pos, dl} = C_{a, dl} w \ell_a^2$$

$$M_{b, pos, dl} = C_{b, dl} w \ell_b^2 \quad \text{where } w = \text{uniform dead load per unit area}$$

Ratio $m = \frac{\ell_a}{\ell_b}$		Case 1	Case 2	Case 3	Case 4	Case 5	Case 6	Case 7	Case 8	Case 9
1.00	$C_{a, dl}$	0.036	0.018	0.018	0.027	0.027	0.033	0.027	0.020	0.023
	$C_{b, dl}$	0.036	0.018	0.027	0.027	0.018	0.027	0.033	0.023	0.020
0.95	$C_{a, dl}$	0.040	0.020	0.021	0.030	0.028	0.036	0.031	0.022	0.024
	$C_{b, dl}$	0.033	0.016	0.025	0.024	0.015	0.024	0.031	0.021	0.017
0.90	$C_{a, dl}$	0.045	0.022	0.025	0.033	0.029	0.039	0.035	0.025	0.026
	$C_{b, dl}$	0.029	0.014	0.024	0.022	0.013	0.021	0.028	0.019	0.015
0.85	$C_{a, dl}$	0.050	0.024	0.029	0.036	0.031	0.042	0.040	0.029	0.028
	$C_{b, dl}$	0.026	0.012	0.022	0.019	0.011	0.017	0.025	0.017	0.013
0.80	$C_{a, dl}$	0.056	0.026	0.034	0.039	0.032	0.045	0.045	0.032	0.029
	$C_{b, dl}$	0.023	0.011	0.020	0.016	0.009	0.015	0.022	0.015	0.010
0.75	$C_{a, dl}$	0.061	0.028	0.040	0.043	0.033	0.048	0.051	0.036	0.031
	$C_{b, dl}$	0.019	0.009	0.018	0.013	0.007	0.012	0.020	0.013	0.007
0.70	$C_{a, dl}$	0.068	0.030	0.046	0.046	0.035	0.051	0.058	0.040	0.033
	$C_{b, dl}$	0.016	0.007	0.016	0.011	0.005	0.009	0.017	0.011	0.006
0.65	$C_{a, dl}$	0.074	0.032	0.054	0.050	0.036	0.054	0.065	0.044	0.034
	$C_{b, dl}$	0.013	0.006	0.014	0.009	0.004	0.007	0.014	0.009	0.005
0.60	$C_{a, dl}$	0.081	0.034	0.062	0.053	0.037	0.056	0.073	0.048	0.036
	$C_{b, dl}$	0.010	0.004	0.011	0.007	0.003	0.006	0.012	0.007	0.004
0.55	$C_{a, dl}$	0.088	0.035	0.071	0.056	0.038	0.058	0.081	0.052	0.037
	$C_{b, dl}$	0.008	0.003	0.009	0.005	0.002	0.004	0.009	0.005	0.003
0.50	$C_{a, dl}$	0.095	0.037	0.080	0.059	0.039	0.061	0.089	0.056	0.038
	$C_{b, dl}$	0.006	0.002	0.007	0.004	0.001	0.003	0.007	0.004	0.002

† A crosshatched edge indicates that the slab continues across, or is fixed at the support; an unmarked edge indicates a support at which torsional resistance is negligible.

- c) In an end span, the total factored static moment  $M_0$  shall be distributed as specified in Table 6.6.6.

Table 6.6.6  
Distribution of Factored Moment in End Span

Position of Moment	Exterior Edge Unrestrained	Slab with Beams between all Supports	Slab Without Beams between Interior Supports		Exterior Edge Fully Restrained
			Without Edge Beam	With Edge Beam	
Interior negative factored moment	0.75	0.7	0.70	0.70	0.65
Positive factored moment	0.63	0.57	0.52	0.50	0.35
Exterior negative factored moment	0	0.16	0.26	0.30	0.65

Table 6.6.7  
Portions of Interior Negative Moments to be Resisted by Column Strip

$\ell_2/\ell_1$	0.5	1.0	2.0
$(\alpha_1 \ell_2/\ell_1) = 0$	75	75	75
$(\alpha_1 \ell_2/\ell_1) \geq 1$	90	75	45

Note: Linear interpolations shall be made between values shown.

- b) Column strips shall be proportioned to resist the portions in percent of exterior negative factored moments specified in Table 6.6.8.

Table 6.6.8  
Portions of Exterior Negative Moments to be Resisted by Column Strip

$\ell_2/\ell_1$		0.5	1.0	2.0
$(\alpha_1 \ell_2/\ell_1) = 0$	$\beta_t = 0$	100	100	100
	$\beta_t \geq 2.5$	75	75	75
$(\alpha_1 \ell_2/\ell_1) \geq 1$	$\beta_t = 0$	100	100	100
	$\beta_t \geq 2.5$	90	75	45

Note: Linear interpolations shall be made between values shown.

- c) Where supports consist of columns or walls extending for a distance equal to or greater than three-quarters the span length  $\ell_2$  used to compute  $M_0$ , negative moments shall be considered to be uniformly distributed across  $\ell_2$ .
- d) Column strips shall be proportioned to resist the portions in percent of positive factored moments specified in Table 6.6.9.

Table 6.6.9  
Portions of Positive Moment to be Resisted by Column Strip

$\ell_2/\ell_1$	0.5	1.0	2.0
$(\alpha_1 \ell_2/\ell_1) = 0$	60	60	60
$(\alpha_1 \ell_2/\ell_1) \geq 1$	90	75	45

Note: Linear interpolations shall be made between values shown.

**The University of Asia Pacific**  
**Department of Civil Engineering**  
**Final Examination Fall 2009**  
**Program: B. Sc. Engineering (Civil)**

Course Title: Environmental Engineering I

Course Code: CE 331

Time: 3 Hours

Full Marks: 150

---

Answer any **six** out of **eight** questions. The figures in the right margin indicate full marks.

- 1.a) What are the objectives of water supply system? Discuss briefly the essential elements of water supply system with a flow diagram. (13)
- b) Mention the methods of making population estimations. Which method do you consider best for population estimation in Dhaka city? Explain. (07)
- c) What is meant by 'fire demand' and how is it computed? (05)
- 2.a) Describe briefly the factors affecting per capita water consumption. (10)
- b) Write a note on 'fluctuations in the rate of water consumption'; explaining its significance in the design of water works system. (08)
- c) The population of a community was 18,000 in 1990 and 24,000 in 2000. Calculate the population in 2015 by the Empirical method. Also calculate the fire demand for the population in 2015 by Kuichling's method (07)
- 3.a) Briefly explain the problems in ground water development in Bangladesh. (10)
- b) What is water-hammer? How can you reduce the water-hammer effect in water works practices? (08)
- c) Determine the diameter of a tube well for the following data: (07)  
Yield = 0.18 cumec, thickness of the confined aquifer = 36 m, draw down = 6 m, radius of circle of influence = 325 m, coefficient of permeability = 60 m/d.
- 4.a) How will you test the soundness of your construction before bringing a pipeline into commission? (07)
- b) What are the steps involved in the design of tube wells? State the basic requirements of a well screen. What do you understand by 'well development'? (12)
- c) Differentiate between direct rotary method and reverse circulation method of drilling deep tube wells. (06)
- 5.a) What are the sanitary significance and WHO guideline values of the following impurities in water? Chloride, Fluoride, Turbidity, Arsenic. (08)
- b) Explain the theories of filtration. (08)

- c) Distinguish between the following terms: (09)
- i) Recarbonation and Aeration
  - ii) Coagulation and Flocculation
  - iii) Hardness and Alkalinity
- 6.a) Show that the efficiency of settling tank is dependent on surface area, not depth of the tank. (08)
- b) Explain the process of arsenic removal by the method of co-precipitation and adsorption indicating the possible chemical reactions involved. (10)
- c) Design a rectangular settling basin for a flow of 4.5 MLD. The over-flow rate is 0.025 cm/s and the detention period is 2.5 h. Calculate the weir length required if the weir loading is  $130 \text{ m}^3/\text{d}/\text{m}^2$ . (07)
- 7.a) What are the advantages and disadvantages of branched and looped distribution networks? (08)
- b) State the systematic procedure of calculation of flow in a looped network by Hardy Cross method. (07)
- c) From a clear water reservoir 4 m deep and M.W.L. 32.00 m water is to be pumped to an elevated reservoir M.W.L. at 70.00 m at the constant rate of 950,000 litres per hour. The distance is 1400 m. Design the pump and the rising main. Assume friction factor = 0.01 and efficiency of the pump = 75%. (10)
- 8.a) Why is the Tara hand pump tube well developed and being prompted in Bangladesh? (04)
- b) Calculate the minimum capacity of the storage tank required for a family of 7 persons to be supplied with 10 lpcd of rain water. The yearly rainfall intensity is 2.6 m and the rainfall distribution is such that at least 35% of the rain water must be stored for uninterrupted water supply throughout the year. Also calculate the minimum catchment area required when the coefficient of runoff is 0.7. (06)
- c) Write short notes on any three of the following: (15)
- i) Water pricing
  - ii) Water use and re-use
  - iii) Necessity and forms of community participation in WSS projects.
  - iv) Blow off valves and Air valves

**The University of Asia Pacific**  
**Department of Civil Engineering**  
**Final Examination Fall-2009**  
**Program: B. Sc. Engineering (Civil)**

Course Title: Geotechnical Engineering I  
 Time: 3 hours

Course Code: CE 341  
 Full Marks: 120 (6 x20 =120)

**There are eight (8) questions below. Answer any Six (6).**

- 1 a) Mention (names only) various types of soils based on their origin and transportation agents. 3  
 b) Classify and discuss (with sketches), in brief, the major characteristics of different types of soil structures. 11  
 c) Discuss, in brief, the general properties of sand, silt and clay found in nature. 6
- 2 a) Write short notes on (any two):  
 (i) Poorly-graded and well-graded soils (ii) Consistency Limits 5  
 (iii) Relative density of soil  
 b) From the following sieve analysis data, determine the gradation of the soil with proper justification. What is the effective size of this soil? 9

Sieve No./ Opening	Amount Retained (gm)	% Retained	Cumulative % Retained	% Finer
# 4 (4.75 mm)	0.0	0.0	0.0	100.00
# 8 (2.36 mm)	24.0	6.0	---	94
# 16 (1.18 mm)	38.9	---	---	84.27
# 30 (0.6 mm)	101.8	---	---	---
# 50 (0.3 mm)	109.4	27.35	68.53	31.47
# 100 (0.15 mm)	73.4	18.35	---	---
# 200 (0.075 mm)	34.6	8.65	95.53	4.47
Pan	17.9			

**Total = 400 gm**

--- To be calculated

- e) From the following information below determine the consistencies of different strata. 6

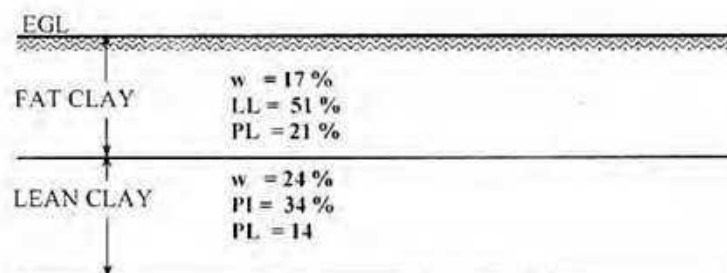

Use the following information for determination of consistencies.

Range of Liquidity Index, $I_L$ (%)	Consistency (degree of firmness)
<0	Hard
0 - 20	Very Stiff
20 - 40	Stiff
40 - 60	Medium Stiff (Firm)
60 - 80	Soft
80 - 100	Very Soft

3a) Derive the following relationship: 4

(i) 
$$S = \frac{wG_s}{e}$$

The symbols carry their usual meanings.

b) With the aid of three-phase-diagram define, void ratio, porosity and degree of saturation. 5

c) For moist sand, stockpiled as shown below, given total volume  $V = 8.38 \text{ ft}^3$ ; total weight  $W = 838 \text{ lbs}$ ; moisture content  $w = 5\%$ ; and specific gravity of soil solids,  $G_s = 2.62$ . Calculate the moist unit weight, dry unit weight, volume occupied by soil solid, volume occupied by water, void ratio, porosity and degree of saturation. If the maximum and minimum void ratios of this stockpiled soil are 0.85 and 0.55, respectively, also calculate the relative density of the soil. 11

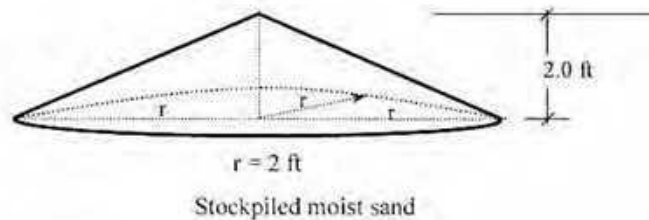

4a) Laboratory test results of the following inorganic soil samples are summarized in the following table. Classify the soils (Use Attachments Chart-1, Chart-2, Chart-5, Chart-6 and Simplified Plasticity Chart as needed) according to ASTM D-2487 (Unified Soil Classification System). 9

Soil Sample No.	Atterberg Limits		% passing through # 200 sieve	% retained on # 200 sieve	% retained on # 4 sieve
	Liquid Limit	Plastic Limit			
1	51	21	63	---	14
2	20	17	53	23	---
3 ( $C_u = 6.3$ $C_c = 2.7$ )	20	15	10	45	---

--- To be calculated

b) With the aid of three-phase-diagram explain the basic mechanism of compaction. 5

c) The laboratory test data for a compaction test are given below. Generate the compaction curve and determine the maximum dry unit weight and optimum moisture content from the curve. 6

Outside diameter of the mold = 162.5 mm; Inside diameter of the mold = 150 mm  
Height of the mold = 150 mm

Weight of Wet Soil in Mold (kN)	Moisture content (%)	Dry Unit Weight ( $\text{kN/m}^3$ )
0.049	12	16.5
0.052	14	17.2
0.054	16	---
0.055	18	---
0.054	20	17.0
0.053	22	16.4

--- To be calculated

- 5a) Three permeable soil layers (silt, sand and gravel) are underlain with an impervious stratum as shown in the following figure. For all given conditions, calculate the permeabilities of the silt, sand and the gravel layers in mm/s. 6

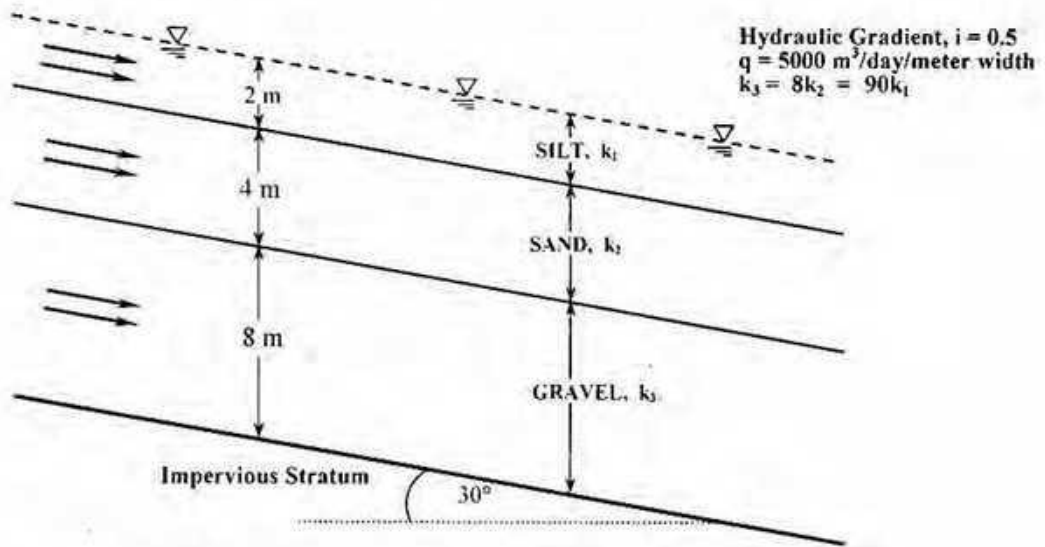

- 5b) For the flow net as drawn in the following figure calculate: 6
- (i) Hydrostatic pressures at locations a, b and c
  - (ii) Seepage loss per unit width
  - (iii) Seepage loss through a single channel.

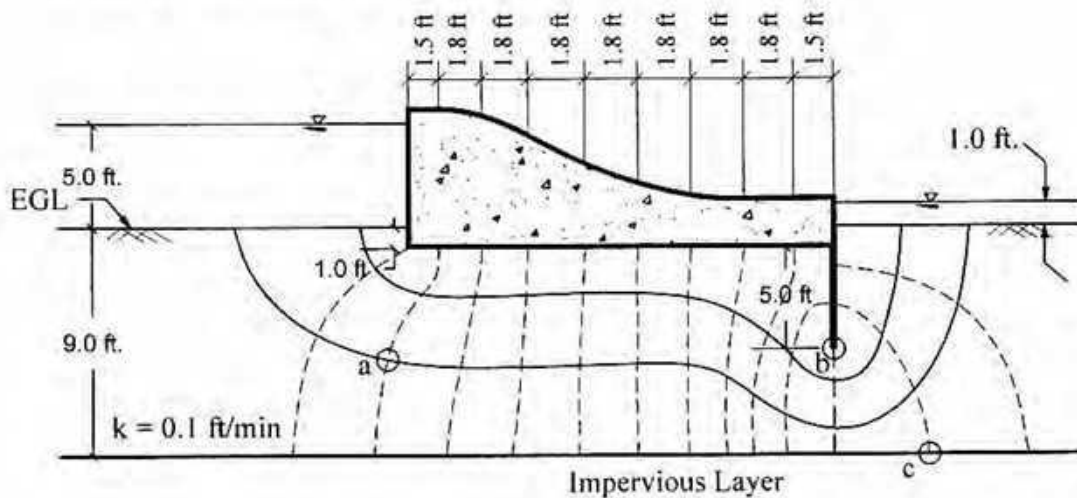

- c) Draw the uplift pressure diagram for the weir shown in question 5 a) and calculate the uplift force (only magnitude; location is not required) per unit width of the weir along its axis. 8

- 6a) Distributed loads acting on a flexible composite rectangular area are given as shown in the following figure. Determine the vertical stress increment at 4 ft below (existing ground surface) of point A. 6

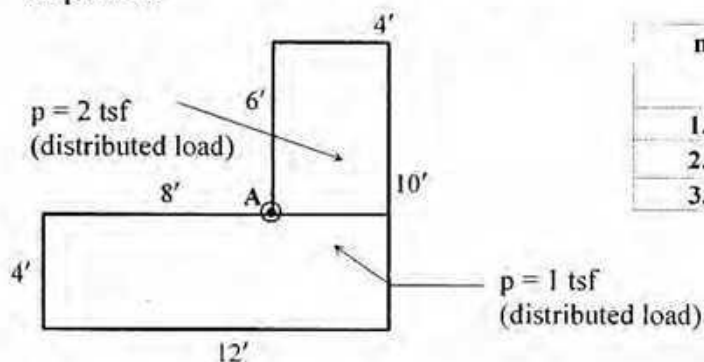

m	n		
	1.0	2.0	3.0
1.0	0.1752	0.1999	0.2034
2.0	0.1999	0.2358	0.2378
3.0	0.2034	0.2378	0.2439

- b) Plot the variations of total stress, pore water pressure and effective stresses with depth for the sand and clay layers shown in the following figure. 10

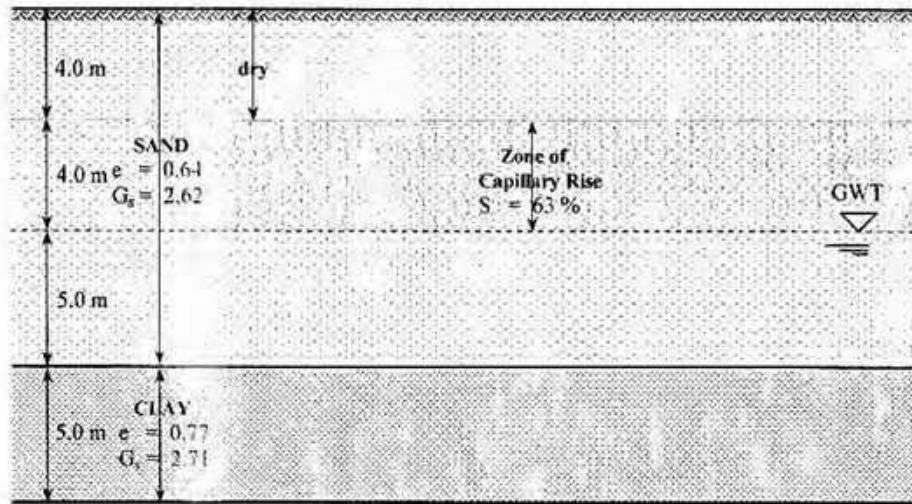

- c) The sand layer as shown in the following figure underlying the clay layer is under Artesian pressure. Heaving condition was observed at this site when an excavation proceeded up to a depth of 2.75 m below EGL. Estimate the Artesian pressure of the sand layer? 4

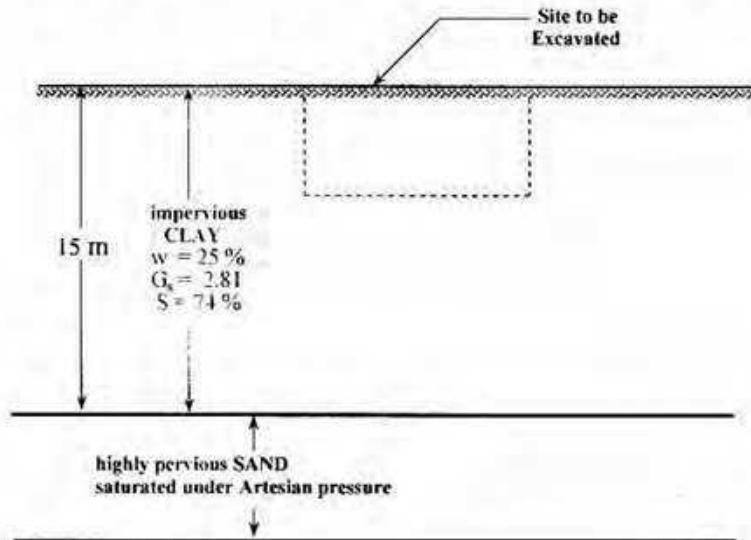

- 7a) Write short notes on normally consolidated (NC) soil and over-consolidated (OC) soil. 3
- b) Calculate the settlement due to primary consolidation for the 10-ft saturated clay layer due to the dry filling soil as shown in the figure in the next page. 8.5

During the sub-soil exploration, a consolidation test was conducted in the laboratory on a clay sample that was obtained from the middle of the clay layer (i.e. about 15 ft below the EGL). The results of the consolidation test are also summarized.

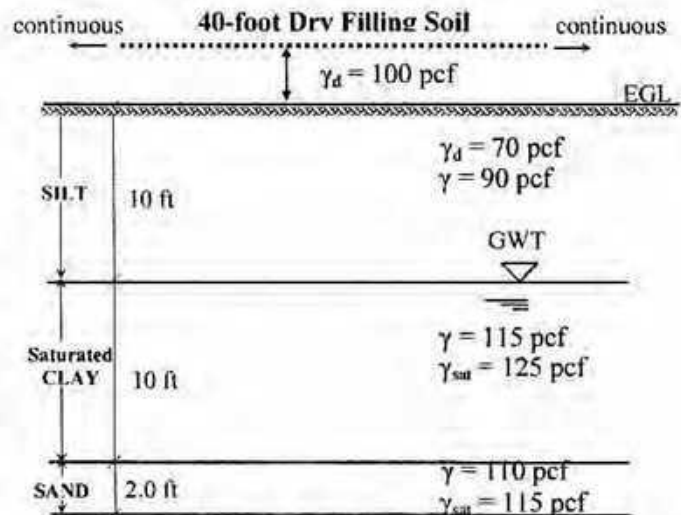
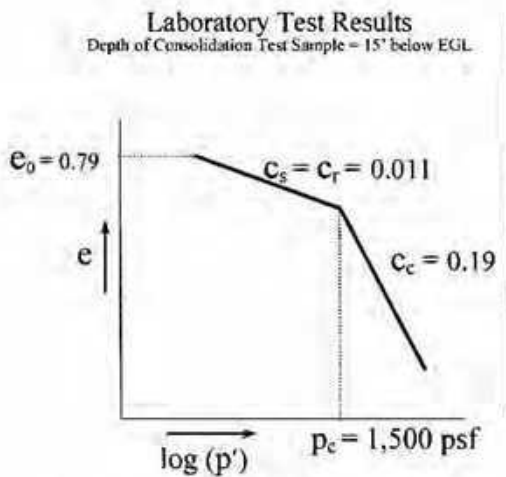

- c) Calculate the lateral force (magnitude, direction and location) per unit width of the structure shown below for at-rest condition. 8.5

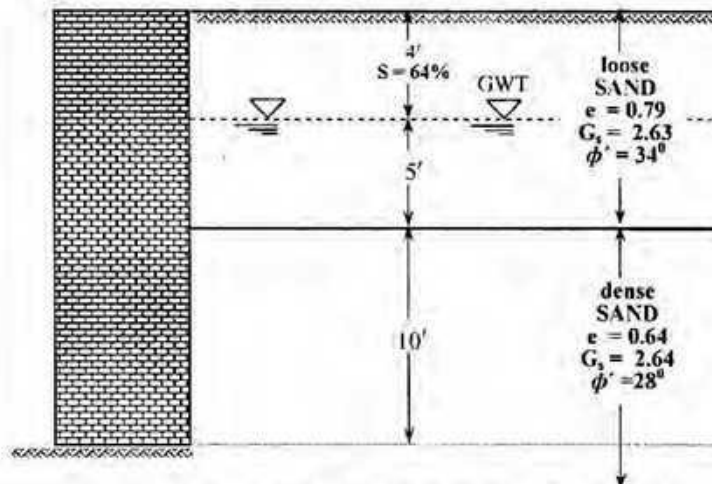

- 8a) For an over-consolidated clay soil derive the expressions for estimation of primary consolidation settlements, given that  $S = \frac{H_0}{1+e_0} \Delta e$ ; where symbols carry their usual meanings. 6
- b) A series of shear tests were performed on identical soil samples. Each test was carried out until the soil samples failed in shear. The principal stresses, at failure, for each test are given in the table below. Without using Mohr's circle, determine the shear strength parameters of this type of soil. Also determine the angle which the failure plane makes with the major principal plane. 7

Test	$\sigma_3$ (kN/m <sup>2</sup> )	$\sigma_1$ (kN/m <sup>2</sup> )
1	30	180
2	80	340
3	130	500

- c) Determine the shear strength parameters of the same soil used in the experiment as described in question no. 8b) using Mohr's circle. 7

**The University of Asia Pacific**  
**Department of Civil Engineering**  
**Final Examination Fall 2009**  
**Program: B.Sc. Engineering (Civil)**

Course Title: Transportation Engineering I  
 (Transport & Traffic Design)

Course Code: CE 351

Time: 3 Hours

Full Marks: 100

There are SEVEN questions. Answer any FIVE.

1. (a) What are the different causes of traffic congestion? How can you eliminate congestion by Traffic Engineering tools? (10)
- (b) Design a two-phase signal of an isolated cross-junction for the following data. And also find saturation flow. Assume any other missing data. (10)

	N - S	E - W				
Inter-green (sec)	9	7				
Lost time (sec)	3	2				
			N	S	E	W
Arrival flow	(PCU/hr)		750	550	600	750
Saturation flow	(PCU/hr)		2010	1950	1810	1820

2. (a) Briefly explain the different government policies on transport planning in Bangladesh. (12)
- (b) What is All-red-period in traffic signal? (3)
- (c) Describe different constraints of highways in Bangladesh. (5)
3. (a) Classify and describe traffic sign according to function. (7)
- (b) What are the advantages and disadvantages of rotary intersection? (6)
- (c) How can you present traffic volume data? (3)
- (d) Write a short note on origin and destination survey. (4)
4. (a) Write down the responsibilities of the following ministries involved in the transportation control and management system in Bangladesh (10)
- i) Ministry of Communication
- ii) Ministry of Civil Aviation and Tourism
- iii) Ministry of Shipping
- (b) Write a short note on different road markers. (7)
- (c) Mention the places where parking should be prohibited. (3)
5. (a) Describe traffic signal according to function. (8)
- (b) What are the common causes of parking related accidents? (4)
- (c) What is Traffic Engineering? (3)
- (d) What are the general requirements of traffic control devices? (5)

6. (a) Briefly differentiate between (6)  
 i) Running speed and Journey speed  
 ii) Free flow and Forced flow  
 iii) Geometric delay and Operational delay
- (b) Write down the objective of traffic volume studies. (5)
- (c) Mention the color convention of road marking. (3)
- (d) Write short notes on i) right of way ii) shoulder iii) pavement crown. (6)
7. (a) What are the different factors that are responsible for large bicycling demand in a country? Mention different bicycle facilities. (3+2)
- (b) What is 85<sup>th</sup> percentile speed? (2)
- (c) Two roads are connected by a horizontal circular curve on level ground. Inside the circular curve there exists an obstruction, which may reduce the ability of sight distance. Given the following data, calculate the stopping and passing sight distance required and sight distance available on the curve with figure. (13)
- Given,
- Distance from center of the road to the edge of obstruction,  $c = 205$  ft
  - Radius of the curve = 510 ft
  - Design speed of the road = 50 mph
  - Co-efficient of friction = 0.14
  - Average speed of passing vehicle = 50 mph
  - Average speed of passed vehicle = 40 mph
  - Perception reaction time = 2.5 sec
  - Average acceleration rate = 1.5 mph/sec
  - Time for preliminary delay = 3 sec
  - Average time while passing vehicle occupies the opposite lane = 10 sec

**The University of Asia Pacific**  
**Department of Civil Engineering**  
**Final Examination Fall- 2009**  
**Program: B.Sc. Engineering (Civil)**

Course Title: Open Channel Flow  
 Time: 3 hours

Course Code: CE 361

Credit: 3.00  
 Full Marks: 150

Answer any **SIX** out of **EIGHT** Questions. The figures in the right margin indicate full marks.

- 1 a. Define: (a) Froude Number, and (b) Reynolds Number 5
- b. Find out the average velocity ( $u$ ), kinetic energy correction factor ( $\alpha$ ) and momentum correction factor ( $\beta$ ) for 2 m wide rectangular channel carrying water at 1 m depth. The equation of velocity distribution may be expressed as  $u = 2y^2 + 3y + 5$ . Where,  $y$  = depth of flow measured from the channel bottom. During calculation divide the depth of flow into five equal zones. 6
- c. Show with neat sketches the pressure distribution in curved channels of convex and concave flows. 3
- d. Why the velocity distribution in open channel flow is not uniform? 3
- e. A rectangular channel carrying  $75 \text{ m}^3/\text{s}$  water has a bottom width of 8.0 m. Find (a) Critical depth and energy (b) Super and Sub-critical flow depth when the energy is 7.48 m. 8
- 2 a. For the compound channel shown in figure below, determine the discharge if  $S=0.0002$ . 8

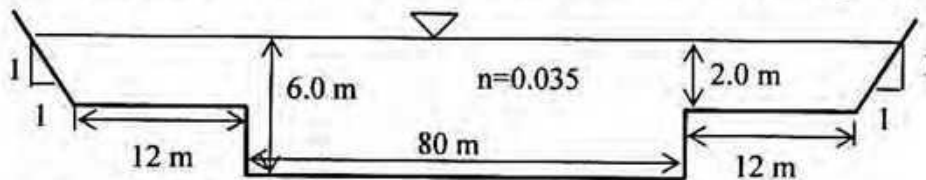

- b. Determine the equivalent roughness of the following irrigation canal. 5

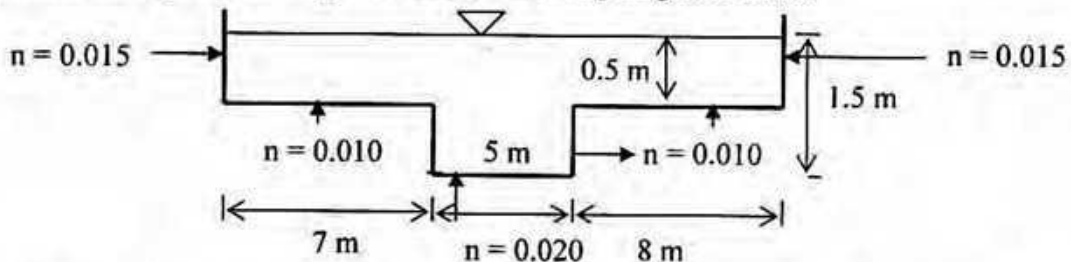

- c. A trapezoidal channel has a bottom width of 8.0 m, side slopes of 2:1, and  $n=0.025$ . 12
  - (a) Determine the normal slope at a normal depth of 1.50 m when the discharge is  $15 \text{ m}^3/\text{s}$ .
  - (b) Determine the critical slope and the corresponding normal depth when the discharge is  $15 \text{ m}^3/\text{s}$ .

- 3 a. Explain why a uniform flow cannot occur (a) in a frictionless channel (b) in a horizontal channel, and (c) channel with adverse slope 6
- b. Mention the factors that affect Manning's roughness coefficient. 5
- c. A concrete lined trapezoidal channel ( $n=0.015$ ) is 10.0 m wide and has a side slope of 2H:1V. The longitudinal slope is 0.006. Estimate the normal depth in this channel for a discharge of 85 m<sup>3</sup>/s. 8
- d. Show that the critical depth ( $y_c$ ) and velocity ( $V_c$ ) for a rectangular channel can be expressed by  $y_c = \sqrt[3]{\frac{q^2}{g}}$  and  $V_c = \sqrt[3]{qg}$  respectively, where 'q' is the discharge per unit width and 'g' is the acceleration due to gravity. 6
- 4 a. Explain with neat sketches how hydraulic jump is formed in a channel? 5
- b. Draw typical velocity distribution curve at a section in hydraulic jump. 4
- c. Explain with neat sketches various types of hydraulic jumps. 8
- d. A spillway discharges a flood flow at a rate of 15.00 m<sup>3</sup>/s per metre width. At the downstream horizontal apron the depth of flow was found to be 1.00 m. Find tail water depth needed to form a hydraulic jump. If a jump is formed, find its (i) type (ii) length and (iii) head loss. 8
- 5 a. A broad crested weir with an upstream square corner and spanning the full width of a rectangular canal of width 2.5 m is planned. The proposed crest length is 4.00 m and the crest elevation is 1.25 m above the bed. Calculate the water surface elevation upstream of the weir when the discharge is 5.0 m<sup>3</sup>/s. 8
- b. A rectangular channel 2.0 m wide has its depth backed-up to a height of 1.2 m by a sharp-crested sluice gate. If the gate opening is 0.30 m and the downstream flow is free, estimate the discharge through the gate. (Assume  $C_d=0.75$ ) 5
- c. A rectangular channel is 3.5 m wide and conveys a discharge of 15.0 m<sup>3</sup>/s at a depth of 2.0 m. It is proposed to reduce the width of the channel at a hydraulic structure. Assuming the transition to be horizontal and the flow to be frictionless determine the water surface elevations upstream and downstream of the constriction when the constricted width is 2.00 m. 12
- 6 a. What do you mean by best hydraulic section? Using the best hydraulic section concept show that the hydraulic radius of a trapezoidal channel is half of the depth of flow. 8
- b. A trapezoidal section is to be built of rough un-sized timber ( $n=0.011$ ) with a drop of 2 m in a km. What will be the depth of water for most efficient section for a flow of 1.1 m<sup>3</sup>/s? 5
- c. Find out the height and width of a stable canal ( 0.5 H : 1 V) using Kennedy's equation to carry a discharge of 15 m<sup>3</sup>/s at a slope of  $2 \times 10^{-4}$ . Given,  $n = 0.025$  and  $m=0.90$ . 6
- d. Find out the height and width of a regime channel ( 0.5 H : 1 V) to carry 10 m<sup>3</sup>/s using Lacey's equation. Mean sediment size of the sand is 0.5 mm. 6

7. a. What is free board? What are the purposes of providing free board? 3  
 b. What are the reasons for lining channels? 4  
 c. Define (a) Tractive force, and (b) Regime Channel 6  
 d. Design a canal to carry 60.00 m<sup>3</sup>/s of clear water through 5.0 mm gravel (Manning's roughness coefficient = 0.015 and angle of repose 37°) on a slope of 10<sup>-4</sup>. The canal is to be trapezoidal in shape having side slopes of 1.5 H: 1 V. The average temperature = 20°C for which  $\nu = 10^{-6}$  m<sup>2</sup>/s and  $\rho_s = 2.65$ . 12

8. a. Mention whether the statement is TRUE or FALSE. 10  
 (i) Zone 3 represents the space above the upper line  
 (ii) In the differential equation of GVF,  $\frac{dy}{dx}$  represents the water-surface slope relative to the bottom of the channel.  
 (iii) Flow profile with  $\frac{dy}{dx} = +ve$  represents a drawdown curve.  
 (iv)  $y_n < y_c$  is the condition for Steep Slope.  
 (v) M<sub>3</sub> flow profile represents sub-critical state of flow.  
 (vi) H<sub>2</sub> flow profile is not possible  
 (vii) C<sub>1</sub> and C<sub>3</sub> Profile are very rare and are highly unstable.  
 (viii) A control section is defined as a section in which a fixed relationship exists between the velocity and depth of flow.  
 (ix) Hydraulic jump is created when flow condition changes from sub-critical to super-critical state.  
 (x) S<sub>3</sub> flow generates from a sluice gate with a steep slope with free flow condition.  
 b. Sketch the possible flow profiles (at least one for each figure) for the following two figures 10

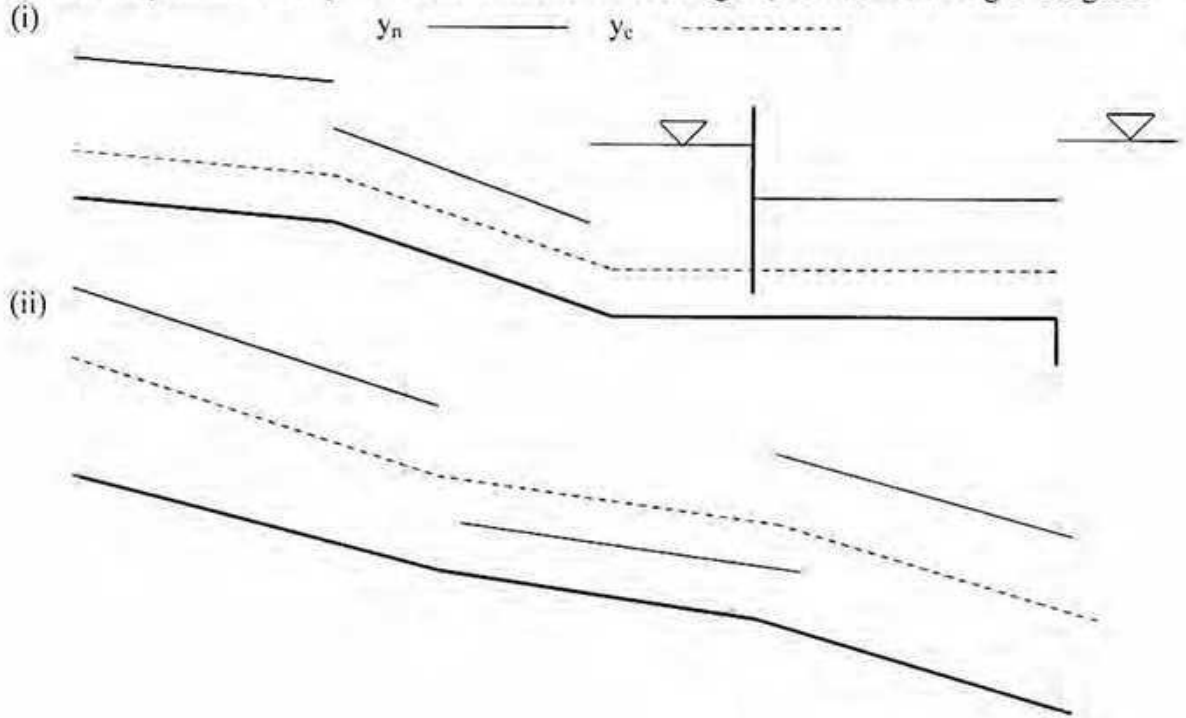

c. Describe each term with neat sketches mentioned in the equation,

$$\frac{dy}{dx} = \frac{S_0 - S_f}{1 - \frac{Q^2 T}{gA^3}}$$

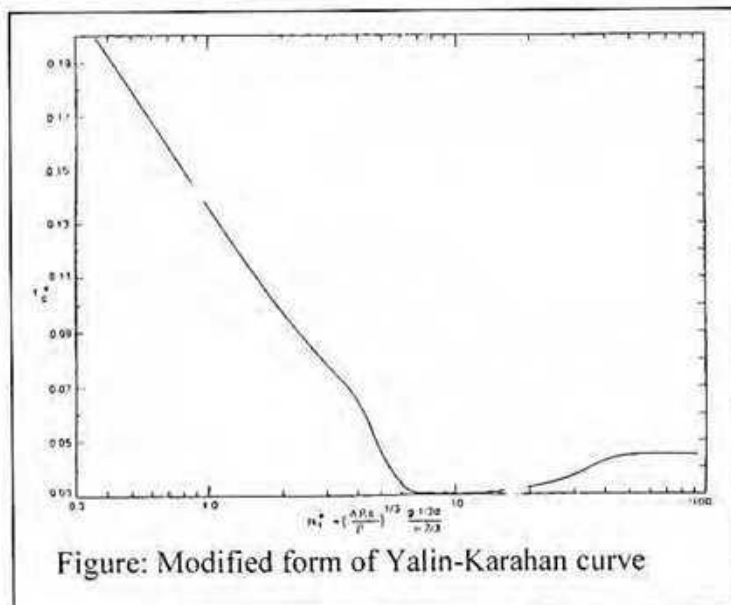
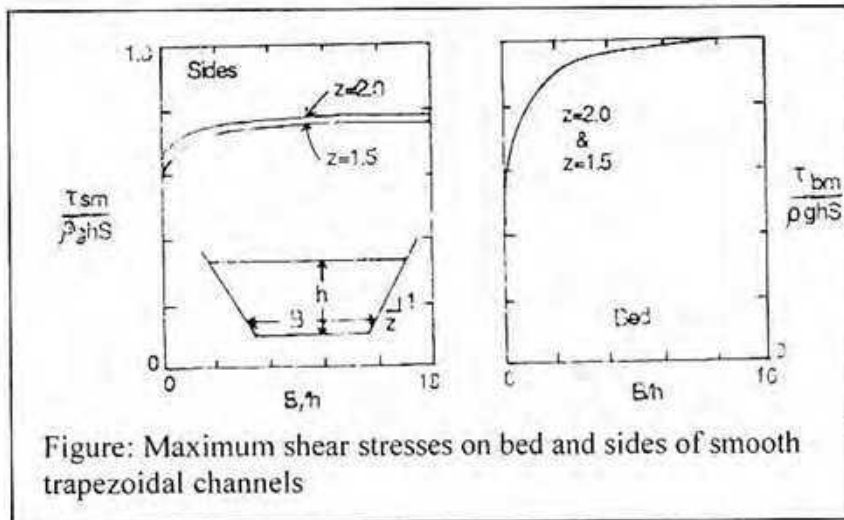
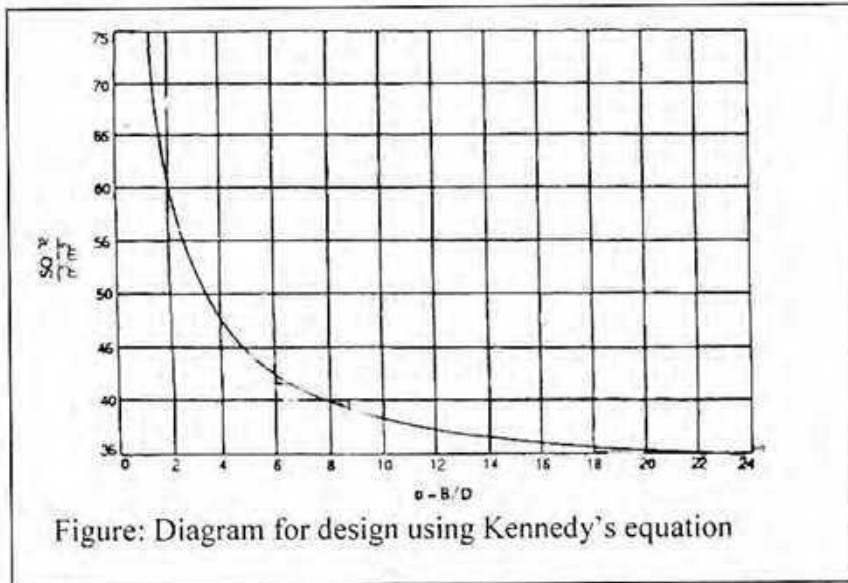

## FORMULAE

$$1. \alpha = \frac{\int v^3 dA}{V^3 A}$$

$$2. \beta = \frac{\sum v^2 \Delta A}{V^2 A}$$

$$3. u = \frac{\int u dy}{y}$$

$$4. P = \gamma h$$

$$5. , h = h_s + c \text{ or, } h = h_s - c$$

$$6. c = \frac{d v^2}{g r}$$

$$7. \left( \frac{P}{\gamma} + Z \right) = \int \frac{V^2}{g r} dr + \text{constan } t$$

$$8. a_n = \frac{v^2}{r}$$

$$9. \frac{y_2}{y_1} = \frac{1}{2} (\sqrt{1 + 8F_1^2} - 1) \text{ or, } \frac{y_1}{y_2} = \frac{1}{2} (\sqrt{1 + 8F_2^2} - 1)$$

$$10. \Delta E = E_1 - E_2$$

$$11. \Delta E = \frac{(y_2 - y_1)^3}{4y_1 y_2}$$

$$12. \frac{L_j}{y_1} = 9.75(F_1 - 1)^{1.01}$$

$$13. E_2 = E_1 - \Delta Z_1$$

$$14. \frac{V_c^2}{2g} = \frac{y_c}{2}, E_c = \frac{3y_c}{2}; y_c = \left( \frac{q^2}{g} \right)^{\frac{1}{3}}$$

$$15. Q = \frac{2}{3} C_d \sqrt{2g} L H_1^{\frac{3}{2}} \quad 16. C_d = 0.611 + 0.08(H_1/P) \text{ which is valid for } H_1/P \leq 5.0$$

$$17. \text{For long weirs, } H_1/B_w \leq 0.1, C_d = 0.561(H_1/B_w)^{0.022}$$

$$\text{For broad crested weirs, } 0.1 \leq H_1/B_w \leq 0.35, C_d = 0.028(H_1/B_w) + 0.521$$

$$\text{For narrow crested weirs, } 0.45 \leq H_1/B_w \leq 1.5, C_d = 0.120(H_1/B_w) + 0.492$$

$$18. Q = C_d A \sqrt{2g \Delta H} \quad 19. V = \frac{1}{n} R^{\frac{2}{3}} S^{\frac{1}{2}} \quad 20. n = \frac{d_{50}^{\frac{1}{6}}}{21.1} \quad 21. n = \frac{d_{90}^{\frac{1}{6}}}{26}$$

$$22. n_{eq} = \frac{(\sum n_i^{\frac{3}{2}} P_i)^{\frac{2}{3}}}{P^{\frac{2}{3}}}$$

$$23. \frac{\tau_s}{\tau_b} = K = \cos \theta \sqrt{1 - \frac{\tan^2 \theta}{\tan^2 \phi}}$$

$$24. \tau_b = 0.90 \tau_c$$

$$25. \tau_c^* = \frac{\tau_c}{g(\Delta \rho_s) d} \text{ Where, } \Delta \rho_s = \rho_s - \rho \quad 26. R_1^* = \left( \frac{\Delta \rho_s}{\rho} \right)^{\frac{1}{3}} \left( \frac{g^{\frac{1}{3}} d}{v^{\frac{2}{3}}} \right)$$

$$27. \begin{matrix} \tau_{bm} \leq \tau_b \\ \tau_{sm} \leq \tau_s \end{matrix} \quad 28. A = (b + zy)y \text{ and } P = b + 2y\sqrt{1+z^2} \quad 29. \frac{Q^2}{g} = \frac{(B + zy_c)^3 y_c^3}{B + 2zy_c} \quad 30. B_c = 1.84 \frac{Q}{\sqrt{g E_1^{\frac{3}{2}}}}$$

31.  $E_1' = 1.5y_c = E_c$  32.  $h = \left[ \frac{1.818Q}{(p + 0.5)m} \right]^{0.378}$  33.  $P = 4.75\sqrt{Q}$

34.  $R = 0.47 \left( \frac{Q}{f_s} \right)^{\frac{1}{3}}$  35.  $S = 3 \times 10^{-4} f_s^{\frac{5}{3}} / Q^{\frac{1}{6}}$  36.  $f_s = 1.76\sqrt{d}$

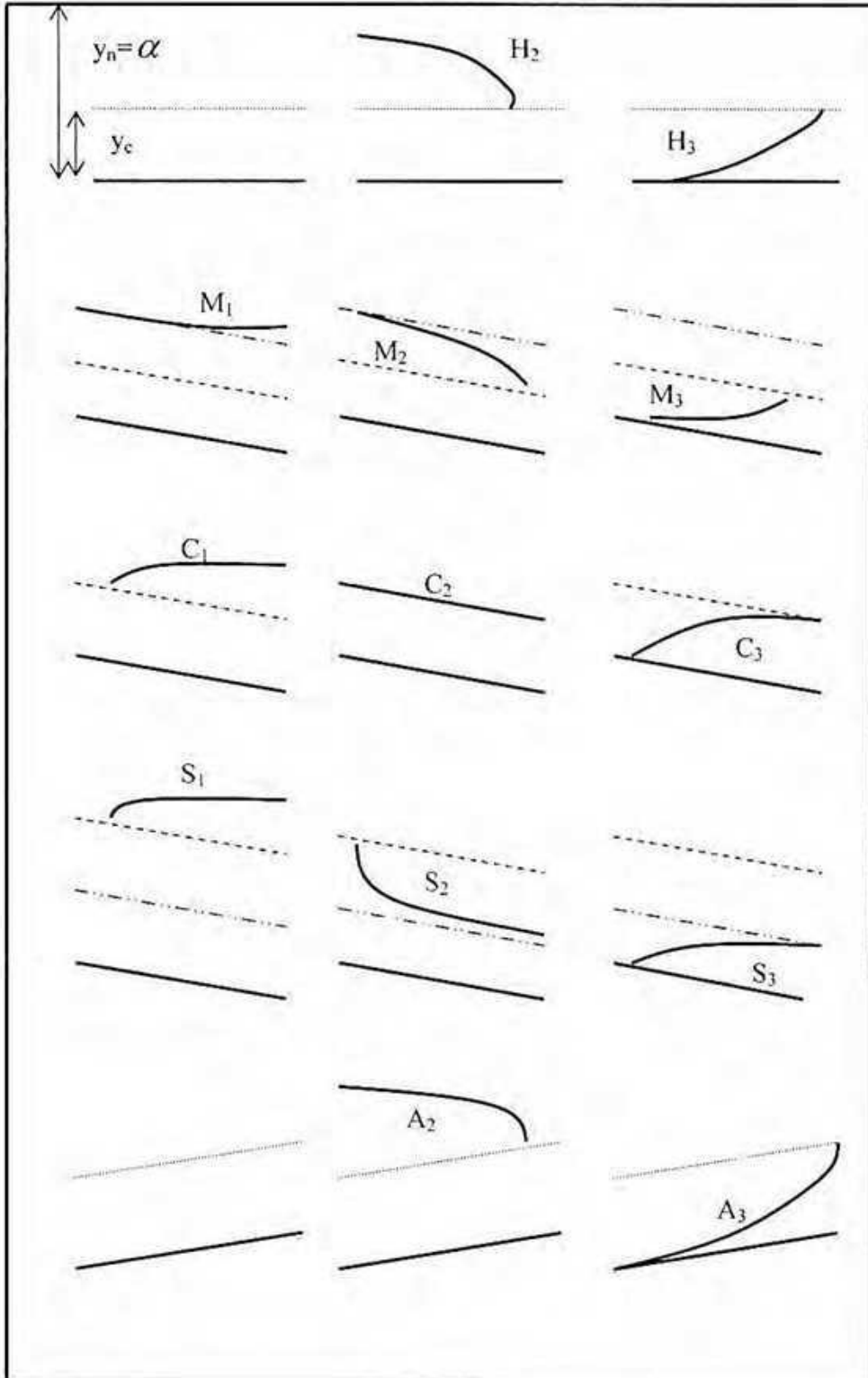

**The University of Asia Pacific**  
**Department of Civil Engineering**  
**Final Examination, Fall 2009**  
**Program: B.Sc Engineering (Civil)**

Course Title: Engineering Hydrology;  
Time: 3 hours

Course Code.: CE 363;

Credit hrs: 3  
Full Marks: 150

**There are eight questions answer Q.#1 and any FIVE**  
(Assume any reasonable data if not given)

1. (a) Explain the following (any Five) (15)
  - i) Raingauge network
  - ii) Intensity – Duration – Frequency relationship
  - iii) Forms of precipitation
  - iv) Precipitable water in a static atmospheric column
  - v) Pan coefficient
  - vi) Life cycle of a frontal cyclone
  - vii) Initial loss to reduce the water volume available for runoff
  
- (b) In a catchment there are six raingauge stations, the normal annual rainfall at the stations being 42.4, 53.6, 67.8, 78.5, 82.7 and 95.5 cm, respectively. Determine the optimum number of raingauge stations to be established in the basin if it is desired to limit the error in the mean value of rainfall over the catchment to 10%. (5)
  
- (c) Explain the various commonly used methods of measurement of stage of a river. (5)
  
2. (a) A reservoir had an average area of 20 km<sup>2</sup>. In a particular month the mean rate of inflow = 10 m<sup>3</sup>/s, outflow = 15 m<sup>3</sup>/s, monthly rainfall = 10 cm and increase in storage = 16 million m<sup>3</sup>. Assuming the seepage losses to be 1.8 cm, estimate the evaporation in that month. (10)
  
- (b) There are four raingauge stations available in and around a catchment whose shape can be approximately describe by straight lines joining the following coordinates (distances in kilometers): (15,0), (25,15), (10,25) and (0,10). Coordinates of the raingauge stations are: (5,0), (15,5), (20,25) and (5,15) and the annual rainfall recorded in them are: 132, 136, 93 and 85cm respectively. Find the mean precipitation for the given catchment by Thiessen polygon method. (15)
  
3. (a) Describe the different methods of base flow separation. (5)
  
- (b) With the help of typical hydrographs describe the salient features of (i) perennial, (ii) intermittent and (iii) ephemeral streams. (5)

(c) The following are the ordinates of a 3-hr unit hydrograph (UH): (15)

Time (hr)	0	3	6	9	12	15	18	21	24	27
Ordinates of 3 hr UH (cumec)	0	1.5	4.5	8.6	12	9.4	4.6	2.3	0.8	0

Determine the flood hydrograph due to a 6-hour storm producing a total rainfall 4.5 cm in the first 3 hours and 3.5 cm in the next 3 hours. Assume an average infiltration loss of 0.5cm/hr and a constant base flow of 3 cumec.

4. (a) What are the assumptions of a unit hydrograph? (3)

(b) Explain the procedure of deriving a synthetic unit hydrograph for a catchment by using Snyder's method. (10)

(c) The stream flows due to three successive storms of 3.5, 4.5 and 2.5 cm of 6 hours duration each on a basin are given below. The area of the basin is 45.4 km<sup>2</sup>. Assuming a constant base flow of 10 cumec, and an average storm loss of 0.25 cm/hr derive the ordinates of a 6 hr unit hydrograph for the basin. (12)

Time (hr)	0	3	6	9	12	15	18	21
Flow (cumec)	10	14	18	32	46	54	58	49
Time (hr)	24	27	30	33	36	39		
Flow (cumec)	36	25	17	12	11	10		

5. (a) Describe the different types of evaporimeters in common use. (10)

(b) Explain energy budget method of estimating evaporation from lake. (4)

(c) Explain the salient features of a current meter and also describe the procedure of using a current meter for measuring velocity in a stream. (5)

(d) In a 140 minutes storm the following rates of rainfall were observed in successive 20 minutes intervals: 3.0, 3.0, 9.0, 6.6, 1.2, 1.2 and 6.0 mm/h. Assuming the  $\Phi$  index value as 3.0 mm/h and an initial loss of 0.8 mm, determine the total rainfall and net runoff. (6)

6. (a) Derive the required expression and different steps for channel routing. (5)

(b) The inflow and outflow hydrographs for a reach of a river are given below. Determine the best values of the Muskingum coefficients  $k$  and  $x$  for the reach. (20)

Time (hr)	Inflow (cumec)	Outflow (cumec)
0	35	39
24	125	52
48	575	287
72	740	624
96	456	638
120	245	394
144	144	235
168	95	142
192	67	93
216	50	60

7. (a) How does channel routing differ from reservoir flood routing? What are the factors to be considered in choosing the routing period? (5)

(b) The storage, elevation and outflow data of a reservoir are given below: (20)

Elevation (m)	Storage $10^6 \times m^3$	Outflow discharge ( $m^3/s$ )
299.50	4.8	0
300.20	5.5	0
300.70	6.0	15
301.20	6.6	40
301.70	7.2	75
302.20	7.9	115
302.70	8.8	160

The spillway crest is at elevation 300.20 m. The following flood flow is expected into the reservoir.

Time(h)	0	3	6	9	12	15	18	21	24	27
Discharge ( $m^3/s$ )	10	20	52	60	53	43	32	22	16	10

If the reservoir surface is at elevation 300.0m at the commencement of the inflow, route the flood to obtain (a) the outflow hydrograph and (b) the reservoir elevation vs. time curve.

8. (a) What are the different methods to estimate the magnitude of a flood peak. Explain the rational method of computing the peak discharge. (7)

(b) The following data give flood data statistics of two rivers around Dhaka city; (18)

River	Length of records (years)	Mean annual flood ( $m^3/s$ )	$\sigma_{n-1}$
Buriganga	92	6437	2951
Shitalakya	54	5627	3360

(i) Estimate the 100 and 1000 year floods for these two rivers by using Gumble's method.

(ii) What are the 95% confidential intervals for the predicted values?



**The University of Asia Pacific**  
**Department of Architecture**  
**Final Examination Fall-2009**  
**Program: B. Architecture**

Course Code: CE381  
 Time: 2 Hours

Credit Hours: 2.0

Course Title: Structure-III  
 Full Marks: 50 (= 10 × 5)

*Assume reasonable values for any missing data*  
**There are 7 (Seven) questions. Answer any 5 (Five)**

**Q-1:** A fixed ended beam supports a uniformly distributed load of 3 k/ft. Find the equation of the deflection by using fourth-order differential equation. Also calculate the deflection at mid span. [Given: The flexural rigidity  $EI = 30000 \text{ k-ft}^2$ ].

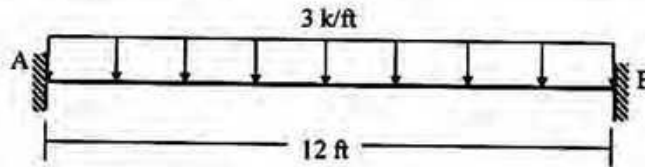

**Q-2:** Using moment area theorem, calculate the deflection at A and rotation at A and B of the beam shown below. [Given:  $EI_{AB} = EI_{CD} = 20000 \text{ k-ft}^2$ ,  $EI_{BC} = 40000 \text{ k-ft}^2$ ].

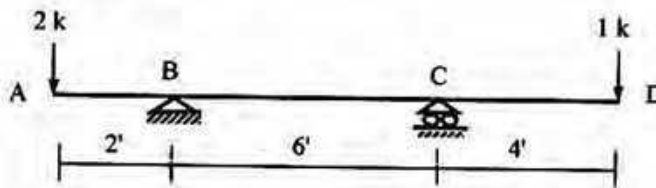

**Q-3:** Using moment area theorem, calculate the deflection at B and rotation at left and right of B of the beam shown below. [Given:  $EI = 30000 \text{ k-ft}^2$ ].

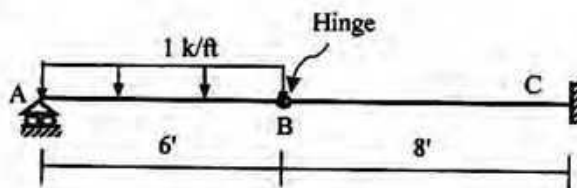

**Q-4:** The state of stress for an element is shown below. Using stress-transformation equations: (a) find the normal stresses and shearing stress acting on the indicated inclined plane. (b) find the principal stresses and show their sense on properly oriented elements. (c) calculate the maximum shearing stress and show their sense on properly oriented elements.

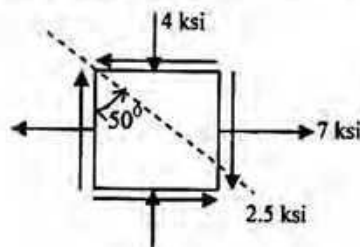

**Q-5:** Find the shear stress at the level indicated below for  $V=25$  kips and also draw the shear stress distribution diagram.

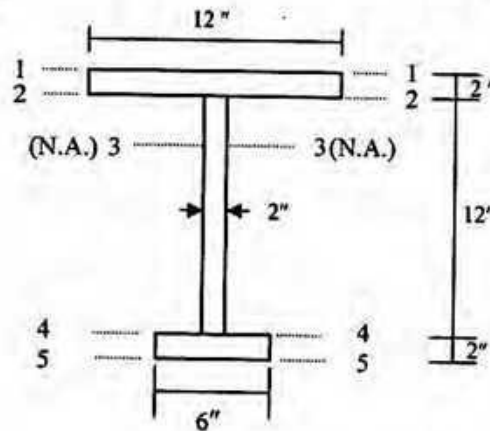

**Q-6:** Calculate the maximum allowable concentrated force  $P$  (in kip) in the beam loaded as shown below, if the allowable compressive stress is 10 ksi and allowable tensile stress is 8 ksi.

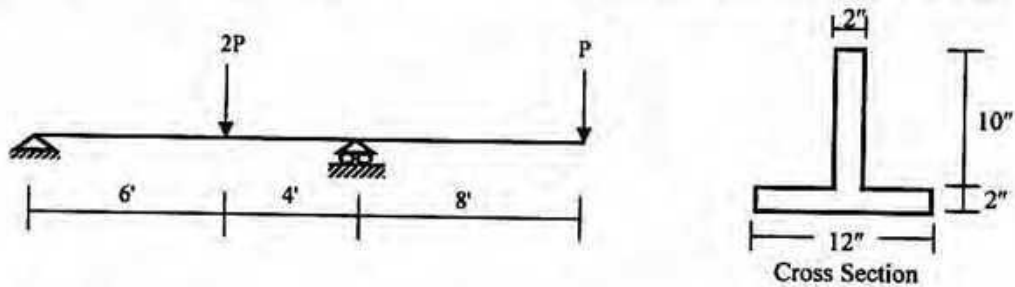

**Q-7:** For a simply supported beam loaded as shown below, draw the flexural stress diagram over the composite cross-sectional area at the mid span of the beam. [Given: Modulus of elasticity of steel = 30,000 ksi, Modulus of elasticity of concrete = 5000 ksi].

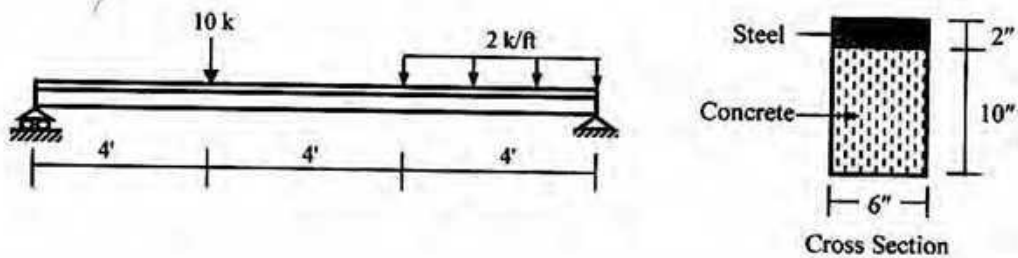

**Formula:**

$$1. \sigma' = \frac{\sigma_x + \sigma_y}{2} \pm \frac{\sigma_x - \sigma_y}{2} \cos 2\theta \pm \tau_{xy} \sin 2\theta$$

$$2. \tau_{xy}' = -\frac{\sigma_x - \sigma_y}{2} \sin 2\theta + \tau_{xy} \cos 2\theta$$

$$3. (\sigma')_{\max/\min} = \frac{\sigma_x + \sigma_y}{2} \pm \sqrt{\left(\frac{\sigma_x - \sigma_y}{2}\right)^2 + \tau_{xy}^2}$$

$$\tan 2\theta_1 = \frac{\tau_{xy}}{(\sigma_x - \sigma_y)/2}$$

$$4. \tau_{\max/\min} = \pm \sqrt{\left(\frac{\sigma_x - \sigma_y}{2}\right)^2 + \tau_{xy}^2}$$

$$\tan 2\theta_2 = -\frac{(\sigma_x - \sigma_y)/2}{\tau_{xy}}$$

$$5. \sigma' = \frac{(\sigma_x + \sigma_y)}{2}$$

**The University of Asia Pacific**  
**Department of Civil Engineering**  
**Final Examination Fall 2009**  
**Program: B. Sc. Engineering (Civil)**

Course Title: Project Planning & Management  
Time: 3 Hours

Course Code: CE 401  
Full Marks: 100

There are SEVEN Questions. Answer any FIVE QUESTIONS.

- 1 A company manufactures two products A and B. These products are processed in the same machine. It takes 10 min to process each unit of product A and 2 min for each unit of product B. Machine operates for a maximum of 35 hrs in a week. Product A requires 1 kg and B requires 0.5 kg of raw material per unit. Total available raw material is 600 kg/week. Minimum market demand of product B is 800 units per week. Product A costs Tk. 5 per unit and sold at Tk. 10, product B costs Tk. 6 per unit and can be sold in the market at a unit price of Tk. 9. (20)

If the objective function is profit maximization, graphically determine the optimum number of units of A and B to be produced. Also calculate the maximum profit.

- 2 a) There are three different types of organization structure of projects. Explain whether conflict is beneficial or not for each of these structures. (6)  
b) What do you mean by Work Breakdown Structure (WBS)? Discuss WBS with six level indentured structure. (6)  
c) Find the EOQ for the following data: (8)

Annual Demand	= 1000 unit
Ordering cost	= \$ 15 per order
Holding cost	= \$ 4 per unit per year
Cost per unit	= \$ 20 for lot size 1~99
	= \$ 19.75 for lot size 100~199
	= \$ 19.60 for lot size 200~299
	= \$ 19.40 for lot size 300~399
	= \$ 19.25 for lot size 400~up

What will be the total cost for this amount of order quantity including material price?

- 3 a) Project manager is often termed as "Conflict Manager" – discuss. (5)  
b) Briefly explain any five major elements of Project Planning. (8)  
c) Calculate IRR for the following cash flow table: (7)

Year	Cash flow
0	Tk 1,500 (investment)
1	600
2	800

- 4
- For any kind of factory, there are several types of material kept in a warehouse. Do you think all of these materials are stored in the same way? If not, which principle is followed to store different kinds of material? Explain. (6)
  - PERT and CPM both techniques can solve the network problems for a Project. Mention their differences based on the type and application area. (4)
  - For the following task table, draw the AON network diagram, find critical path and calculate total duration of the project as well as slack time for each task: (10)

Task	Successor	Duration (days)
A	C	5
B	D	3
C	E, F	4
D	F, G	6
E	H	7
F	H, I	4
G	I	8
H	---	6
I	---	5

- 5
- How can you distinguish partnering from chartering in negotiation? Discuss. (4)
  - Explain 3 different types of cybernetic control system. (8)
  - Consider a project that requires 30 units of products to be produced. An expert worker takes 14 hrs to complete a single part. However, 23 parts need to be produced for a worker to be an expert at 70% learning rate. With an hourly wage rate of Tk 50, how much the budget will be underestimated if the learning effect is not considered? (8)
- 6
- What are the benefits and limitations of GANTT chart over Network? Out of these two, which one do you think easier to understand for the workers? Justify your answer. (3)
  - Elaborate how to collect data in monitoring a project. (5)
  - For the following task table, find different possible crash time and corresponding costs for the project: (12)

Activity	Predecessor	Duration (days)		Cost (Tk)	
		Normal	Crash	Normal	Crash
a	---	3	3	400	400
b	a	4	2	200	500
c	a	3	2	200	200
d	a	4	2	500	1100
e	b	3	1	100	500
f	c	4	3	200	500

- 7
- Briefly discuss the items in a contractual document. (8)
  - Elaborate the main causes of accidents in construction works. (6)
  - What are the general items in construction work that are covered by inspection and quality control? (6)

### Learning Rate Coefficients

Unit Number	70%		75%		80%		85%		90%	
	Unit Time	Total Time	Unit Time	Total Time	Unit Time	Total Time	Unit Time	Total Time	Unit Time	Total Time
1	1.000	1.000	1.000	1.000	1.000	1.000	1.000	1.000	1.000	1.000
2	0.700	1.700	0.750	1.750	0.800	1.800	0.850	1.850	0.900	1.900
3	0.568	2.268	0.634	2.384	0.702	2.502	0.773	2.623	0.846	2.746
4	0.490	2.758	0.563	2.946	0.640	3.142	0.723	3.345	0.810	3.556
5	0.437	3.195	0.513	3.459	0.596	3.738	0.686	4.031	0.783	4.339
6	0.398	3.593	0.475	3.934	0.562	4.299	0.657	4.688	0.762	5.101
7	0.367	3.960	0.446	4.380	0.534	4.834	0.634	5.322	0.744	5.845
8	0.343	4.303	0.422	4.802	0.512	5.346	0.614	5.936	0.729	6.574
9	0.323	4.626	0.402	5.204	0.493	5.839	0.597	6.533	0.716	7.290
10	0.306	4.932	0.385	5.589	0.477	6.315	0.583	7.116	0.705	7.994
11	0.291	5.223	0.370	5.958	0.462	6.777	0.570	7.686	0.695	8.689
12	0.278	5.501	0.357	6.315	0.449	7.227	0.558	8.244	0.685	9.374
13	0.267	5.769	0.345	6.660	0.438	7.665	0.548	8.792	0.677	10.052
14	0.257	6.026	0.334	6.994	0.428	8.092	0.539	9.331	0.670	10.721
15	0.248	6.274	0.325	7.319	0.418	8.511	0.530	9.861	0.663	11.384
16	0.240	6.514	0.316	7.635	0.410	8.920	0.522	10.383	0.656	12.040
17	0.233	6.747	0.309	7.944	0.402	9.322	0.515	10.898	0.650	12.690
18	0.226	6.973	0.301	8.245	0.394	9.716	0.508	11.405	0.644	13.334
19	0.220	7.192	0.295	8.540	0.388	10.104	0.501	11.907	0.639	13.974
20	0.214	7.407	0.288	8.828	0.381	10.485	0.495	12.402	0.634	14.608
21	0.209	7.615	0.283	9.111	0.375	10.860	0.490	12.892	0.630	15.237
22	0.204	7.819	0.277	9.388	0.370	11.230	0.484	13.376	0.625	15.862
23	0.199	8.018	0.272	9.660	0.364	11.594	0.479	13.856	0.621	16.483
24	0.195	8.213	0.267	9.928	0.359	11.954	0.475	14.331	0.617	17.100
25	0.191	8.404	0.263	10.191	0.355	12.309	0.470	14.801	0.613	17.713
26	0.187	8.591	0.259	10.449	0.350	12.659	0.466	15.267	0.609	18.323
27	0.183	8.774	0.255	10.704	0.346	13.005	0.462	15.728	0.606	18.929
28	0.180	8.954	0.251	10.955	0.342	13.347	0.458	16.186	0.603	19.531
29	0.177	9.131	0.247	11.202	0.338	13.685	0.454	16.640	0.599	20.131
30	0.174	9.305	0.244	11.446	0.335	14.020	0.450	17.091	0.596	20.727
31	0.171	9.476	0.240	11.686	0.331	14.351	0.447	17.538	0.593	21.320
32	0.168	9.644	0.237	11.924	0.328	14.679	0.444	17.981	0.590	21.911
33	0.165	9.809	0.234	12.158	0.324	15.003	0.441	18.422	0.588	22.498
34	0.163	9.972	0.231	12.389	0.321	15.324	0.437	18.859	0.585	23.084
35	0.160	10.133	0.229	12.618	0.318	15.643	0.434	19.294	0.583	23.666
36	0.158	10.291	0.226	12.844	0.315	15.958	0.432	19.725	0.580	24.246
37	0.156	10.447	0.223	13.067	0.313	16.271	0.429	20.154	0.578	24.824
38	0.154	10.601	0.221	13.288	0.310	16.581	0.426	20.580	0.575	25.399
39	0.152	10.753	0.219	13.507	0.307	16.888	0.424	21.004	0.573	25.972
40	0.150	10.902	0.216	13.723	0.305	17.193	0.421	21.425	0.571	26.543
41	0.148	11.050	0.214	13.937	0.303	17.496	0.419	21.844	0.569	27.111
42	0.146	11.196	0.212	14.149	0.300	17.796	0.416	22.260	0.567	27.678
43	0.144	11.341	0.210	14.359	0.298	18.094	0.414	22.674	0.565	28.243
44	0.143	11.484	0.208	14.567	0.296	18.390	0.412	23.086	0.563	28.805
45	0.141	11.625	0.206	14.773	0.294	18.684	0.410	23.496	0.561	29.366
46	0.139	11.764	0.204	14.977	0.292	18.975	0.408	23.903	0.559	29.925
47	0.138	11.902	0.202	15.180	0.290	19.265	0.405	24.309	0.557	30.482
48	0.136	12.038	0.201	15.380	0.288	19.552	0.403	24.712	0.555	31.037
49	0.135	12.173	0.199	15.579	0.286	19.838	0.402	25.113	0.553	31.590
50	0.134	12.307	0.197	15.776	0.284	20.122	0.400	25.513	0.552	32.142
51	0.132	12.439	0.196	15.972	0.282	20.404	0.398	25.911	0.550	32.692
52	0.131	12.570	0.194	16.166	0.280	20.684	0.396	26.307	0.548	33.241
53	0.130	12.700	0.192	16.358	0.279	20.963	0.394	26.701	0.547	33.787
54	0.128	12.828	0.191	16.549	0.277	21.239	0.392	27.094	0.545	34.333
55	0.127	12.955	0.190	16.739	0.275	21.515	0.391	27.484	0.544	34.877
56	0.126	13.081	0.188	16.927	0.274	21.788	0.389	27.873	0.542	35.419
57	0.125	13.206	0.187	17.114	0.272	22.060	0.388	28.261	0.541	35.960
58	0.124	13.330	0.185	17.299	0.271	22.331	0.386	28.647	0.539	36.499
59	0.123	13.453	0.184	17.483	0.269	22.600	0.384	29.031	0.538	37.037
60	0.122	13.574	0.183	17.666	0.268	22.868	0.383	29.414	0.537	37.574

**The University of Asia Pacific**  
**Department of Civil Engineering**  
**Final Examination Fall 2009**  
**Program: B. Sc. Engineering (Civil)**

Course Title: Structural Engineering V  
 Time: 2 Hours

Course Code: CE 415  
 Full Marks: 100

[Answer any 5 (five) of the following 7 questions]  
 [Symbols carry their conventional meanings]

- 1.(a) Compute the value of live load that the beam in Fig.1 can carry, producing 1.5 MPa tensile stress (flexural) at midspan section. Use the principle of internal resisting couple (second concept) for the analysis. Given:  $n=7$ , Effective prestress=1400 kN [08]

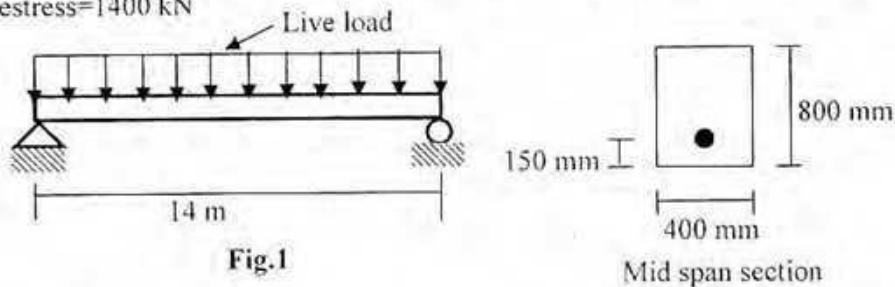

- (b) Compare prestressed and reinforced concrete in terms of serviceability, safety and economy. [06]
- (c) Write down different stages of post-tensioning system with sketches. Explain the advantages of this system. [06]
- 2.(a) A pretensioned concrete member 14.0 m long is eccentrically prestressed with 900 mm<sup>2</sup> of steel wires which are anchored to the bulkheads with a stress of 1000 MPa. Compute the loss of prestress at mid span section (Fig.2a.) due to the elastic shortening of concrete at the transfer of prestress. Assume  $n=7$ . [12]

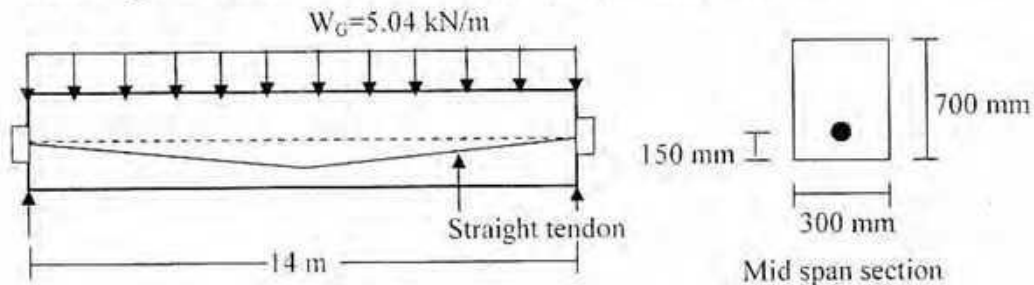

(b) Show with neat sketches the undesirable positions for e.g.s. zone limits in simple beam. [03]

(c) Describe briefly the different sources which cause loss of prestress in a prestressed concrete member. [05]

3.(a) A post-tensioned bonded concrete beam has a prestress of 1500 kN in the steel immediately after prestressing, which eventually reduces to 1300 kN due to losses. The beam carries two live loads of 40 kN each in addition to its own weight of 7.68 kN/m. Compute the extreme fiber stresses at mid span shown in Fig.3. [14]  
 i) at the initial condition with full prestress and no live load  
 ii) at the final condition, after the losses have taken place with full live load.

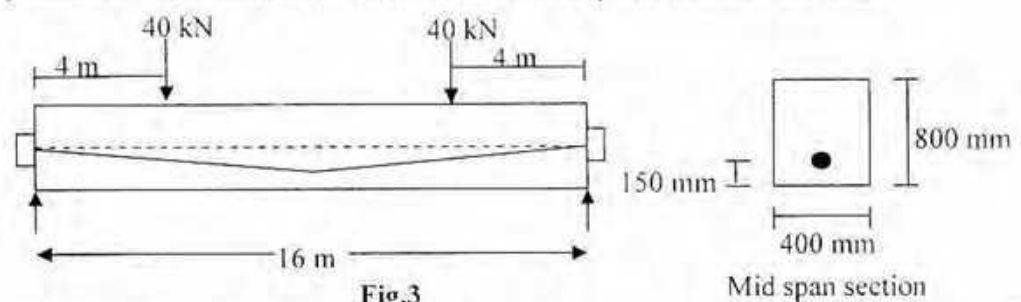

(b) Show the stress distributions in a prestressed concrete beam section for different locations of compressive force (C) according to elastic theory. [06]

4.(a) The mid-span section of a composite beam is shown in the Fig.4. The effective prestress is 1750 kN assuming the total loss as 15%. Compute the stresses in the section at various stages if the bending moment at the section are as follows: [16]

- due to weight of precast stem = 350 kN-m
- due to top slab = 110 kN-m
- due to live load = 550 kN-m

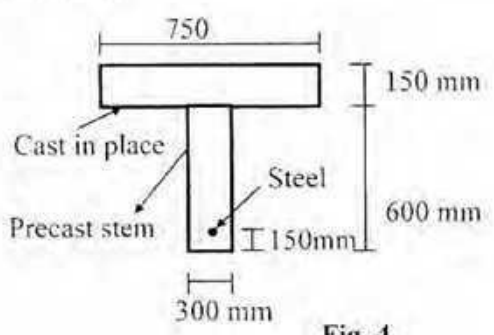

(b) Define "transfer length" in pretensioned concrete member. Write down the parameters which affect the transfer length for prestressing steel of pretensioned member. [04]

5. Design a PC beam for a simply supported span of 20 m having an overall depth of 1.2 m. The beam is to support a total load 15 kN/m including self wt. Design as T-beam and assume total loss=20%. [20]  
 Given:  $f'_c = 30$  MPa,  $f_{pu} = 1720$  MPa,  $f_{so} = 1035$  MPa  
 $f_b = -12.5$  MPa,  $f_t = -11.0$  MPa,  $f'_s = 1.6$  MPa,  $f'_t = 2.1$  MPa  
 Assume, web thickness = flange thickness = 100 mm

- 6.(a) Check shear strength at section 1-1 for the beam shown in Fig.5. Given that this section is adequate for  $w_u = 70 \text{ kN/m}$  on the basis of its flexural strength. [15]

Given:  $f'_c = 40 \text{ MPa}$ ,  $f'_{so} = 1200 \text{ MPa}$ ,  $f_{sc} = 1000 \text{ MPa}$ ,  $A_{ps} = 1760 \text{ mm}^2$

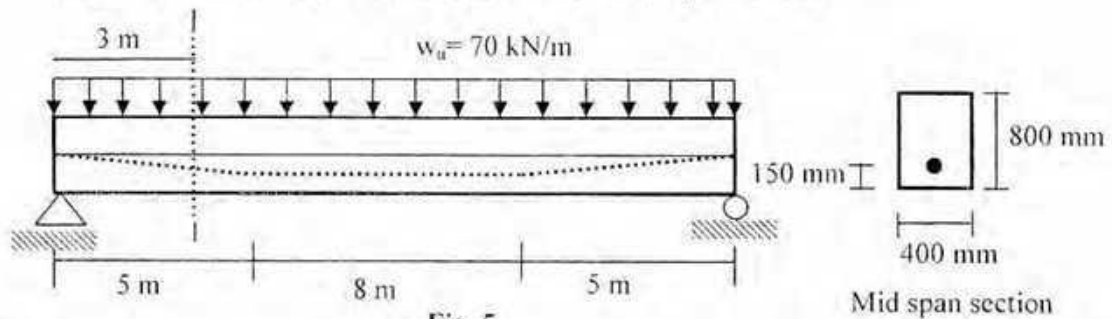

- (b) What are the advantages of partial prestressing? Write down the methods to obtain partial prestressing. [05]
- 7.(a) Calculate the mid-span deflection of a 18 metre span I-beam as shown in the Fig.6 [12]  
 (a) immediately at transfer of prestress and (b) after 15 years.  
 The beam carries a superimposed dead load of 4 kN/m and service live load of 6 kN/m in addition to its self weight. It has to carry a concentrated live load of 75 kN at mid-span.

Assume that superimposed dead load are applied soon after prestress transfer.

Given:  $A_{ps} = 1730 \text{ mm}^2$ ,  $A_c = 240 \times 10^3 \text{ mm}^2$ ,  $I = 2.408 \times 10^{10} \text{ mm}^4$

$f_{pi} = 1300 \text{ MPa}$ ,  $f_{pe} = 1120 \text{ MPa}$  (after 15 years)

$C_u = 2.30$ ,  $\gamma_{con} = 24 \text{ kN/m}^3$

$E_{ci} = 25100 \text{ MPa}$ ,  $E_c = 27400 \text{ MPa}$

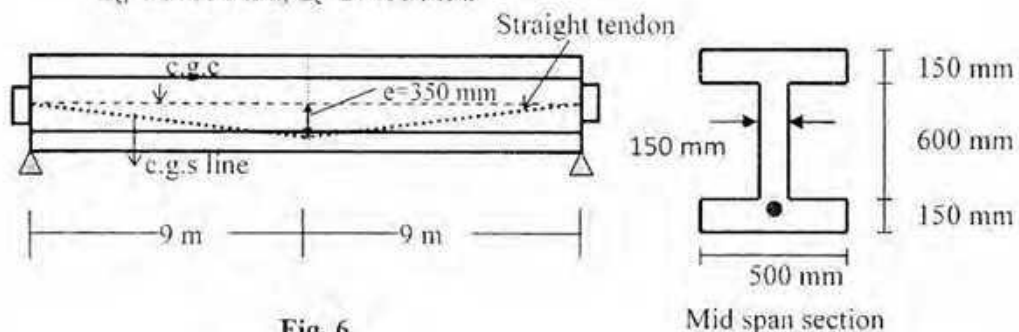

- (b) Show with the sketches the uses of non-prestressed reinforcement at the following stages: [04]
- Just after transfer of prestress
  - At working and ultimate loads
- (c) Show the desirable layouts for simple pretensioned and posttensioned beams. [04]

## Annexure-1

### Formulas

$$\bullet ES = (E_s/E_{ci}) \times f_{cr} = n \times (F_o/A + F_o e^2/I - M_{cr}e/I) \quad [F_o = 0.9F_i \text{ (pretensioned member)}]$$

$$\bullet e = M_G/F_o + k_b$$

$$\bullet e = (M_G + f_i' A k_b)/F_o + k_b$$

$$\bullet F = M_T/(e + k_i)$$

$$\bullet F = (M_T - f_b' A k_i)/(e + k_i)$$

$$\bullet A_c = \frac{F_o h}{f_b c_t - f_i c_b}$$

$$\bullet A_c = \frac{F h}{f_i c_b - f_b c_t}$$

$$\bullet A_c = \frac{F h}{f_i c_b}$$

$$\bullet A_c = \frac{F_o h}{f_b c_t}$$

$$\bullet A_c = \frac{F_o}{f_b} \left( 1 + \frac{e - \left( \frac{M_G}{F_o} \right)}{k_i} \right)$$

$$\bullet V_{cr} = 0.05 \sqrt{f_c'} b_w d + V_d + V_i M_{cr}/M_{max} \geq 0.14 \sqrt{f_c'} b_w d$$

$$\bullet M_{cr} = [1/y_t] \times (0.5 \sqrt{f_c'} + f_{pc} - f_s)$$

$$\bullet V_{sw} = 0.29 \sqrt{f_c'} b_w d + 0.3 f_{pc} b_w d + V_p$$

$$\bullet \Delta = -\Delta_m + \Delta_0$$

$$\bullet \Delta = -\Delta_m - \frac{\Delta_{pr} + \Delta_{pr'}}{2} C_t + (\Delta_0 + \Delta_d)(1 + C_t) + \Delta_l$$



$$\bullet C_t = \frac{t^{0.60}}{10 + t^{0.60}} C_u$$

## Annexure-2

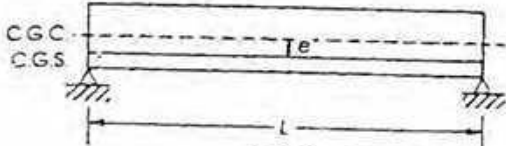
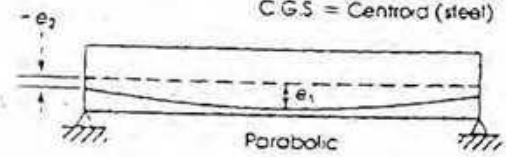
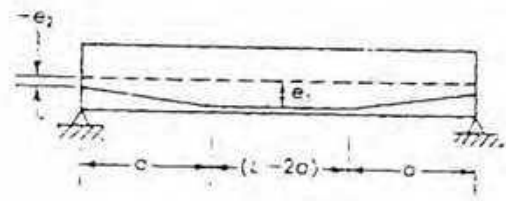
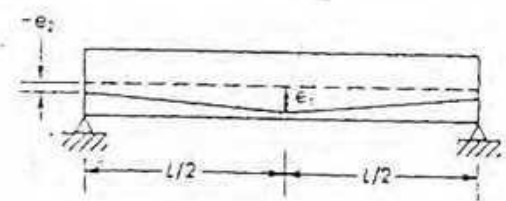
### MIDSPAN DEFLECTIONS OF SIMPLY SUPPORTED BEAMS

Schematic	Deflection equations
Camber due to prestressing force	
 <p style="text-align: center; margin-top: 10px;">CGC = Centroid (concrete) CGS = Centroid (steel)</p>	$\Delta = \frac{(Fe)L^2}{8EI} \quad (1)$ <p style="text-align: center;">(Horizontal tendons)</p>
 <p style="text-align: center;">Parabolic</p>	$\Delta = \frac{FL^2}{8EI} \left[ \frac{5}{6} e_1 + \frac{1}{6} e_2 \right] \quad (2)$ <p style="text-align: center;">When <math>e_2 = 0</math>:</p> $\Delta = \frac{5(Fe_1)L^2}{48EI} \quad (3)$
	$\Delta = \frac{FL^2}{8EI} \left[ e_1 + \frac{4}{3} \left( \frac{a}{L} \right)^2 (e_2 - e_1) \right] \quad (4)$ <p style="text-align: center;">When <math>a = \frac{L}{3}</math>:</p> $\Delta = \frac{FL^2}{8EI} \left[ e_1 - \frac{4}{27} (e_2 - e_1) \right] \quad (5)$ <p style="text-align: center;">When <math>a = \frac{L}{3}</math> and <math>e_2 = 0</math>:</p> $\Delta = \frac{23(Fe_1)L^2}{216EI} \quad (5)$
	$\Delta = \frac{FL^2}{24EI} (2e_1 + e_2) \quad (7)$ <p style="text-align: center;">When <math>e_2 = 0</math>:</p> $\Delta = \frac{(Fe_1)L^2}{12EI} \quad (8)$

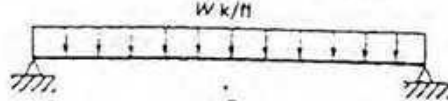
### Deflection due to gravity loads

	$\Delta = \frac{5wL^4}{384EI} \quad (9)$
	$\Delta = \frac{PL^3}{48EI} \quad (10)$

**The University of Asia Pacific**  
**Department of Civil Engineering**  
**Final Examination Fall 2009**  
**Program: B.Sc. Engineering (Civil)**

Course Title: Environmental Engineering III  
 Time: 2 Hours

Course Code: CE 431  
 Full Marks: 100

There are **SEVEN** Questions. Answer any **FIVE** Questions.  
 (Assume reasonable values for missing data)

- I. (a) For the solid waste sample given in the table below. Estimate the Unit Energy content (dry basis) for the sample. (8)

Component	Percent by mass	Moisture content (%)	Energy (kJ/kg)
Food waste	20	70	69,750
Paper	25	6	753,750
Cardboard	12	5	163,000
Plastic	24	2	326,000
Garden Trimmings	5	60	65,000
Wood	10	20	93,000
Tine cans	4	3	3,500

- (b) What are the activities associated with the management of solid wastes from the point of generation to final disposal? (2)

- (c) Composition of solid wastes in a landfill site (containing only organic matter) is given in the following table along with a typical data on ultimate analysis of the combustible portion in the municipal solid wastes. (10)

Component	Wet Mass (kg)	Dry Mass (kg)	Typical Ultimate Analysis Data (dry mass, kg)					
			C	H	O	N	S	Ash
Food Wastes	15	4.6	2.20	0.29	1.70	0.13	0.04	0.24
Paper	45	42.3	18.40	2.54	18.61	0.13	0.08	2.54
Cardboard	10	9.5	4.20	0.60	4.21	0.03	0.02	0.44
Garden Trimmings	10	4.0	1.91	0.24	1.52	0.14	0.01	0.18
Wood	5	4.0	1.90	0.24	1.70	0.10	0.00	0.06

Assuming a chemical composition of the form of  $C_xH_yO_zN_dS$  determine the approximate organic chemical composition (neglect ash content) for the waste. Modified Dulong formula is given as follows:

$$KJ / Kg = 337C + 1428 \left( H - \frac{O}{8} \right) + 9S$$

Estimate the energy content of the waste.

2. (a) Compare two types of collection systems (HCS and SCS) in terms of - (5)  
 1. Pickup time  
 2. Haul time  
 (b) Solid wastes from a commercial area are to be collected using a stationary container collection system having 5 m<sup>3</sup> containers. Determine the appropriate truck capacity for the following conditions: (15)  
 (i) Container utilization factor = 0.70  
 (ii) Average number of container at each location = 3  
 (iii) Collection vehicle compaction ratio = 2.0  
 (iv) Container unloading time = 0.2 h /container  
 (v) Average driving time between container locations = 0.15 h  
 (vi) Round trip haul distance = 80 km  
 (vii) Speed limit = 88 km / h  
 (viii) Time from garage to first container location = 0.33 h  
 (ix) Time from last container location to garage = 0.25 h  
 (x) Number of trips to disposal site per day = 2  
 (xi) Length of workday = 8 h  
 (xii) At-site time = 0.1 h / trip  
 (xiii) Coefficients a = 0.016, b = 0.011
3. (a) Estimate the amount of gases (CH<sub>4</sub>, CO<sub>2</sub> and NH<sub>3</sub>) produced in a sanitary landfill per 150 lb waste having 30% moisture (water), 30% fixed residue and 40% volatile organic matter. The percent composition of the volatile organic materials are C = 40%, O = 48%, N = 5%, H = 7%. The densities of CH<sub>4</sub>, CO<sub>2</sub> and NH<sub>3</sub> are 0.0448, 0.1235 and 0.0482 lb/ft<sup>3</sup> respectively at atmospheric pressure. (10)  
 (b) What factors one should consider in the selection of a landfill site? (5)  
 (c) What are the factors to be considered for laying out collection routes? (5)
4. (a) Briefly describe the most common landfilling methods. (10)  
 (b) What are the generalized phases in the generation of landfill gases? Give brief explanation of each of the phase. (8)  
 (c) What are the steps to be involved in establishing collection routes for municipal solid wastes? (2)
5. (a) Define hazardous wastes according to EPA legislation. Classify hazardous wastes according to processing and treatment operations. (10)  
 (b) Demonstrate the advantage, disadvantage and limitation of biological treatment processes in a tabular form. (10)
6. (a) Briefly describe the processing, treatment and disposal methods for hospital wastes. (10)  
 (b) What are the general disposal options for hazardous wastes? What are the problems associated with treatment and disposal of hazardous wastes in the developing countries? (6)  
 (c) What are the main sources of infectious wastes in the hospitals? (4)
7. (a) What is Autoclaving? Write down the standards for Autoclaving process. (10)  
 (b) Classify the wastes produced in a typical hospital. (5)  
 (c) Draw a flow chart to show human exposure pathways for hazardous wastes. (5)

**The University of Asia Pacific**  
**Department of Civil Engineering**  
**Final Examination Fall 2009**  
**Program: B. Sc. Engineering (Civil)**

Course Title: Environmental Engineering VI  
Time: 2 Hours

Course Code: CE437  
Full Marks: 100

---

There are Six Questions. Answer ANY FIVE questions.

- 1(a) What do you understand by "niche" and "habitat"? Draw a flow-chart showing niche interrelationships and material cycling in aquatic ecosystem. Identify primary producers, consumers and decomposers in the flow-chart. (10)
- (b) What are the principal reasons behind the decline of yield in capture fisheries in Bangladesh? What are the major reasons for reduction in biodiversity in Bangladesh (6)
- (c) What do you understand by IEE? Discuss briefly. (4)
- 2(a) What are the main components of Environmental Management Plan (EMP)? Briefly describe these components. (13)
- (b) What are the major causes of forest depletion in Bangladesh? What are the major adverse impacts of forest depletion? (7)
- 3(a) Write down the steps or draw flow-chart" of actions for securing "environmental clearance" for industries belonging to "red" category. (11)
- (b) What are the major adverse impacts of "global climate change and sea-level rise" in Bangladesh? (5)
- (c) Write down the major environmental issues to be encountered during construction of operation of Power Plants. (4)
- 4(a) What are Millennium Development Goals (MDGs)? Write down any 6 out of the 8 Goals. How will the World look in 2005 if the MDGs are achieved? (11)
- (b) Describe the relationships between project cycle and environmental assessment. (5)
- (c) Give two examples each of industries belonging to "green", "orange A" and "red" categories. (4)
- 5(a) Write down the major functions of Environmental Impact Assessment (EIA). What do you understand by "baseline studies"? Discuss the role of baseline studies in EIA. (11)
- (b) What is ISO14000? Which organizations should be interested in ISO 14000? (5)
- (c) Draw the grazing food-web/chain for aquatic ecosystem. (4)
- 6(a) What are the major objectives of Bangladesh Environment Policy, 1992? Write down the important issues related to each of the following sectors: (i) Agriculture, (ii) Fisheries. (8)

- (b) Classify the "nature of impacts" of projects considered in EIA. Give examples of each type of impact. (5)
- (c) Write down the major environmental issues to be encountered during implementation of "Irrigation Projects". (4)
- (d) What is Earth Summit? When and where it was held? How many principles were adopted in this Summit? (3)

**The University of Asia Pacific**  
**Department of Civil Engineering**  
**Final Examination Fall- 2009**  
**Program: B.Sc. Engineering (Civil)**

Course Title: Environmental Engineering VIII    Course Code: CE 531    Credit: 2.00  
 (GIS and Remote Sensing)

Time: 2 hours    Full Marks: 50

**Answer all questions. Use ArcView software to solve these problems. Use "Fall\_09" data folder.**

7+2+4+2=15

1. Bangladesh district map is given in "District.shp". Soil column represents types of soil and HL column represent Land Type Area in ha. Find,
- Create a map based on soil classification. (use color schemes as "Fruits & Vegetables")
  - Find out how many districts have (i) Floodplain Soil (ii) Hill Soil (iii) Peat & (iv) Terrace
  - Calculate the total area in ha under (i) Floodplain Soil (ii) Hill Soil (iii) Peat & (iv) Terrace
  - Prepare a layout showing district wise soil classification.

3+3+3+6=15

2. a. There are 64 districts (district.shp) in Bangladesh. Create a new theme map of whole Bangladesh.
- b. Add **districts.shp** in your view. There are four airports in Bangladesh. They are situated in Dhaka, Chittagang, Sylhet and Jessore District. Create a point theme map showing the four airports and add attributes as follows:

Shape	Airport	Status	X	Y
Point	Dhaka	International	90.33	23.72
Point	Chittagang	International	91.97	22.27
Point	Sylhet	International	91.87	24.90
Point	Jessore	Domestic	88.60	24.48

Save the newly created point theme map as '**airport.shp**'.

- c. Add **districts.shp** in your view. A highway is proposed from **Dhaka** to **Sylhet** city. Create a line theme map and save it as **highway.shp** and add attributes as follows:

Shape	Highway	Length(km)
Line	Dhaka-Sylhet	350

- d. Bangladesh wants to explore oil and gas in the Bay of Bengal. For this it divides the area under consideration into three zones, namely zone 1, zone 2 and zone 3. Create a new map with the help of existing map. The figures may be as shown below,

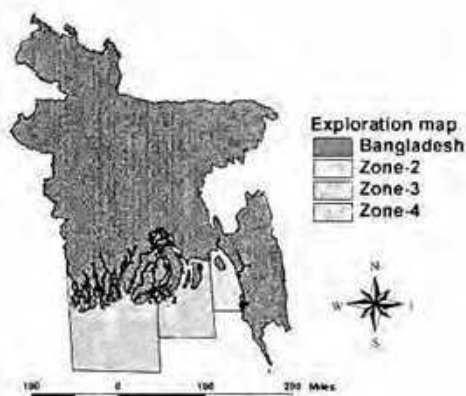

$$6 + 3 + 4 + 4 + 3 = 20$$

3. a. You have a shape file 'uttara.shp' representing a sector in Uttara (Each polygon represents a holding, thus there are 5257 holdings). You have also a map poles.shp representing the position of electric poles (there are 1775 poles). DESA divided their electric poles into five zones, namely zone 1, zone 2, zone 3, zone 4 and zone 5 for daily load shedding management. In the map, zones are represented in "ID" column of poles.shp map. If DESA imposes load-shedding everyday as per the following schedule:

Time	Zone
5.00 pm – 6.00 pm	1
6.00 pm – 7.00 pm	2
7.00 pm – 8.00 pm	3
8.00 pm – 9.00 pm	4
9.00 pm – 10.00 am	5

- Find out, (a) How many holdings will be affected during load shedding at zone 1?  
 (b) How many holdings will be affected during load shedding at zone 2?  
 (c) How many holdings will be affected during load shedding at zone 3?  
 (d) How many holdings will be affected during load shedding at zone 4?  
 (e) How many holdings will be affected during load shedding at zone 5?

Assume, rest of the holdings has no electric line (vacant plot).

- b. There are four community centres at Uttara area namely, (i) Uttara Community Centre (ii) Istikutum Community Centre and (iii) Aponjon Community Centre (iv) Ekuse Community Centre. The locations of the community centres are given in the map 'centres.shp'. Find out the number of holdings situated within a distance of 1500 miles from each community centre.
- c. The path of rail line in Dhaka city is given in the shape file line.shp. There are 4 rail lines in the map namely line-1, line-2, line-3 and line-4. The Dhaka metropolitan map is also given in dhaka\_1.shp. Find out the total number of wards and ward numbers that cross the rail lines 1 to 4.
- d. The Mouza map of Uttara is given in 'sec.shp' and the location of various mobile tower antenna in the sectors are shown in antenna.shp. Find out how many antenna tower are in sectors 4, 6 and 9, respectively.
- e. Dhaka metropolitan map is given in dhaka\_1.shp. What is the area in square km of ward nos 15, 36 and 55? What is the total perimeter of Dhaka city?

**The University of Asia Pacific**  
**Department of Civil Engineering**  
**Final Examination Fall 2009**  
**Program: B. Sc. Engineering (Civil)**

Course Title: Chemistry  
Time: 3 Hours

Course Code: CHEM 111  
Full Marks: 50

---

There are SEVEN Questions. Answer any FIVE.

- |   |  |            |
|---|--|------------|
| 1 | (a) What is reaction rate?<br>Distinguish between (i) instantaneous rate, (ii) average rate and (iii) initial rate.  | 0.5<br>4.5 |
|   | (b) Define order (n) and half-life ( $t_{1/2}$ ) of a reaction.<br>Deduce (i) the integrated rate expression and (ii) $t_{1/2}$ of a first order reaction. | 1.0<br>4.0 |
| 2 | (a) What is hydrosol?<br>Distinguish between 'lyophilic' and 'lyophobic' sols.   | 1.0<br>4.0 |
|   | (b) How the sols are purified by the dialysis process.   | 5.0        |
| 3 | (a) What is dry corrosion?<br>Discuss the aspects of dry corrosion by hydrogen.  | 1.0<br>4.0 |
|   | (b) Classify wet corrosion based on the environment.<br>Discuss the chemical phenomenon of under water corrosion.  | 1.0<br>4.0 |
| 4 | (a) What is 'high polymer'?<br>Discuss homopolymer and copolymer briefly.  | 1.0<br>4.0 |
|   | (b) Give the reaction steps for the preparation of (i) phenol-formaldehyde resin and (ii) melamine.  | 5.0        |
| 5 | (a) What are the environmental segments?<br>Discuss the composition of various chemical species present in the atmosphere.                                 | 1.0<br>4.0 |
|   | (b) Mention the reactions taking place in the atmosphere involving the following: (i) oxides of nitrogen and (ii) chlorine.                                | 5.0        |
| 6 | (a) Write down the important physical properties of water.<br>Draw and explain the possible structures of water molecule.                                  | 2.0<br>3.0 |
|   | (b) Discuss the chemical reactions of water with (i) metals and (ii) non-metals.   | 5.0        |
| 7 | (a) Define 'solution' clearly.<br>Discuss the mechanism of dissolution of a solid in liquid.   | 1.0<br>4.0 |
|   | (b) What is solubility?<br>Show that solubility of a solute in a solvent at a fixed temperature is constant.   | 1.0<br>4.0 |

**The University of Asia Pacific**  
**Department of Civil Engineering**  
**Semester Final Examination, Fall - 2009**  
**Program: B. Sc Engineering (2<sup>nd</sup> Year/ 1<sup>st</sup> Semester)**

Course Title: Basic Electrical Engineering      Course No. ECE 201      Credit Hours: 3.00

Time: 3.00 Hours

Full Marks: 150

[There are **eight** questions. Answer any **six**. Figures in the right margin indicate marks]

1. a. Find the  $R_{eq}$  as indicated in the following figure. All the resistances are given in ohms. [15]

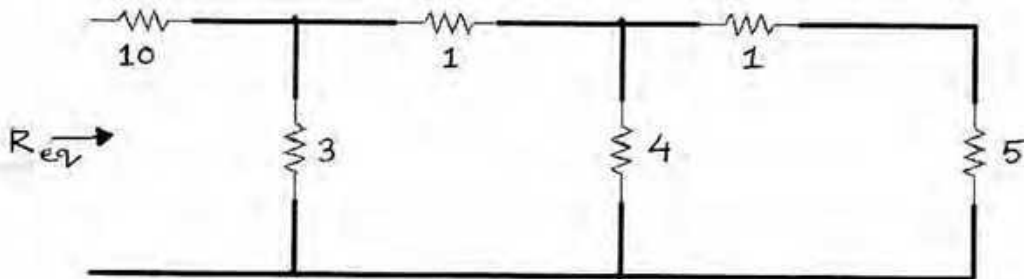

- b. Find  $V_x$  and  $V_o$  in the following circuit using KVL. All the resistances are given in ohms. [10]

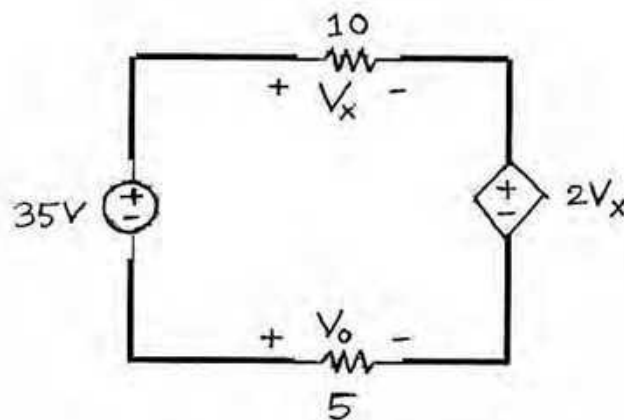

2. a. Find  $V_o$  in the following circuit using Nodal Analysis. All the resistances are given in ohms. [15]

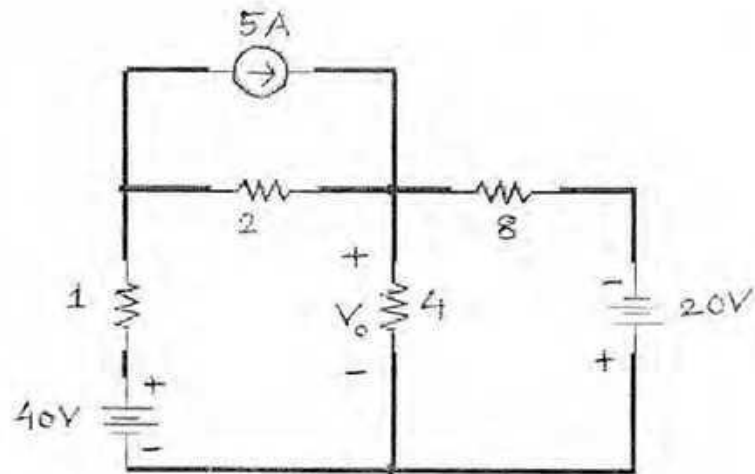

- b. Find Node Voltages in the following circuit. All the resistances are given in ohms. [10]

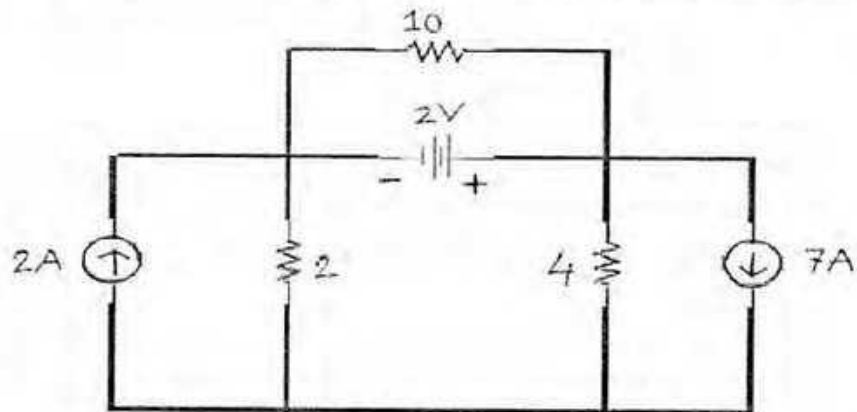

3. Find  $I$  in the following circuit using Superposition Theorem. All the resistances are given in ohms. [25]

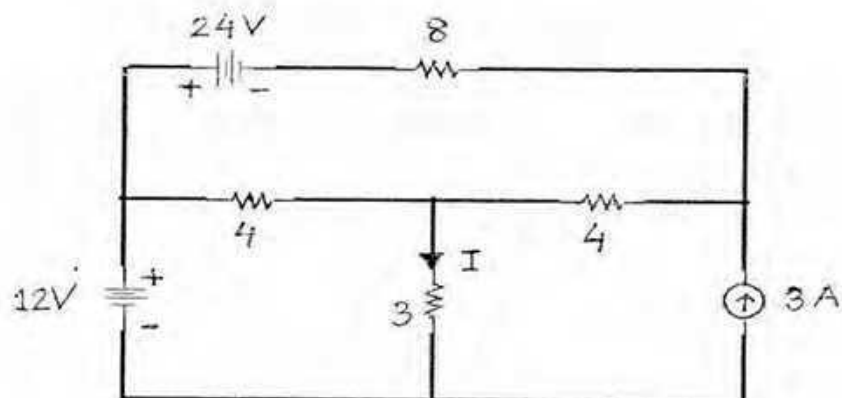

4. a. State and derive Maximum Power Transfer Theorem. [10]

- b. Using Thevenin's Theorem find  $V_{th}$  and  $R_{th}$  in the terminals a-b in the following circuit. [15]  
All the resistances are given in ohms.

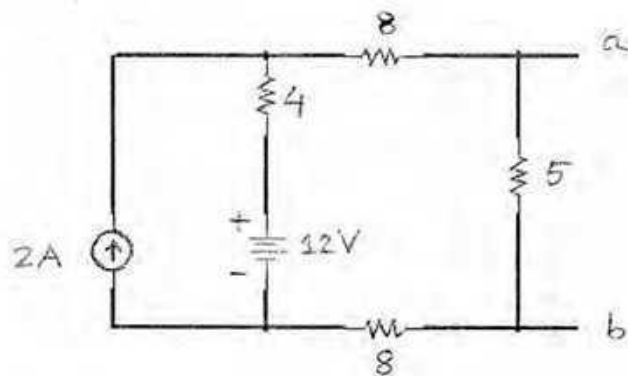

5. a. Find Mesh currents in the following circuit. All the resistances are given in ohms. [10]

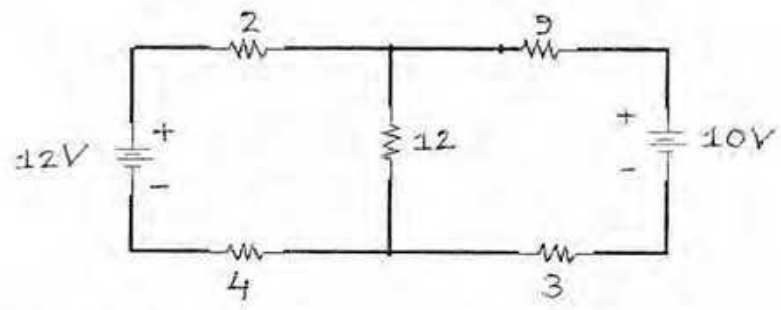

- b. Find  $I_x$  in the following circuit using Mesh Analysis. All the resistances are given in ohms. [15]

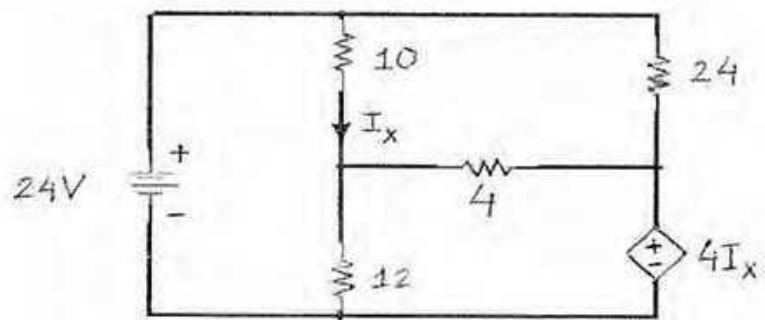

6. a. Find the capacitor voltage in the following circuit in both Phasor Domain and Time Domain. Resistance is given in Ohm. [15]

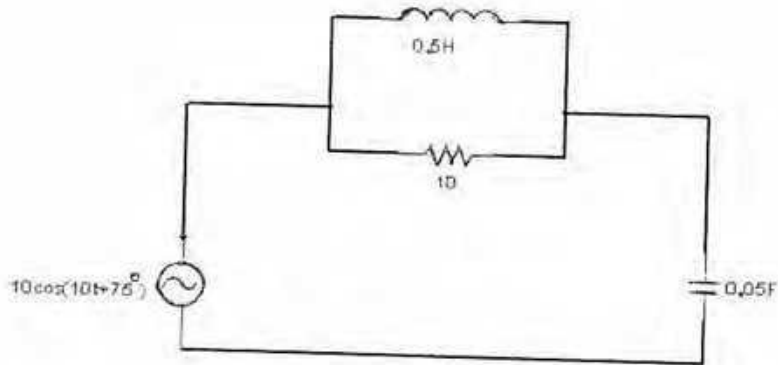

- b. Prove that for a sinusoidal signal  $e(t)$ , the Phasor form of  $de(t)/dt$  is  $j\omega\tilde{E}$ . [10]
7. a. Find all the branch currents in the following circuit. Also draw the vector diagram. Resistance is given in Ohm. [15]

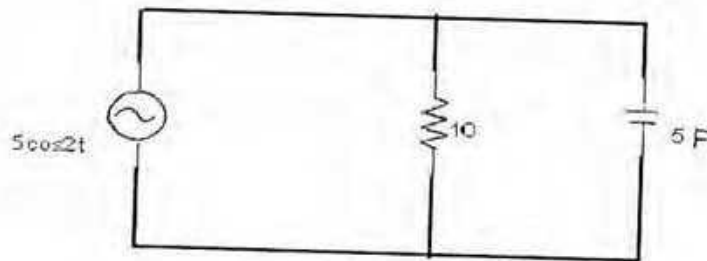

- b. Explain resonance in an R-L-C series circuit. Derive the equation of Resonant frequency. Draw the Current versus frequency curve. [10]
8. a. Define Magnetic Flux Density. Draw and explain the Hysteresis curve. [10]
- b. Determine the current  $I$  in the following magnetic circuit. Section lengths:  $l_{ab} = l_{cd} = l_{ef} = l_{gh} = l_{bc} = 4$  inch,  $l_{de} = 0.5$  inch. Area (throughout) = 1 square inch,  $\Phi = 3.5 \times 10^{-1}$  Wb. The B-H curve for Sheet Steel and Cast Iron is provided with the question. B is in Tesla (T) and H is in Ampere Turn per meter (At/m) in the curve. [15]

*Handwritten notes:*  
 $i = \frac{v}{R}$   
 $\frac{10 \cos(10t + 75^\circ)}{10}$

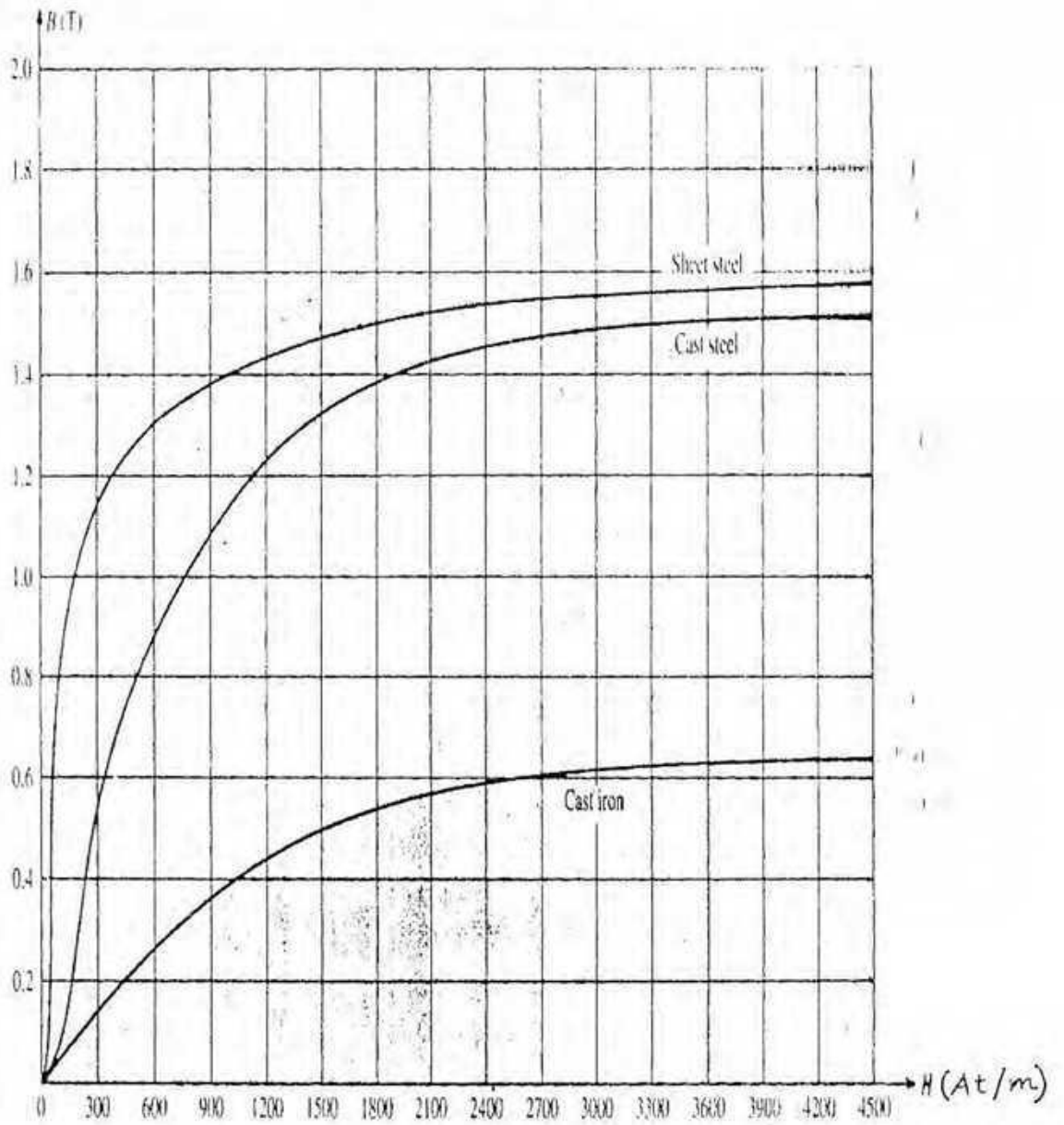
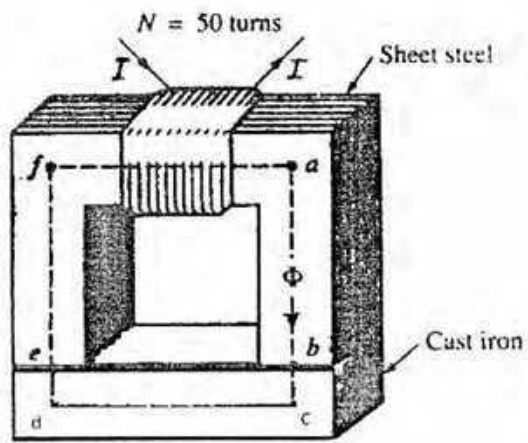

**The University of Asia Pacific**  
**Department of Civil Engineering**  
**Final Examination Fall 2009**  
**Program: B.Sc. Engineering (Civil)**

Course Title: Principles of Economics  
Time: 2 Hours

Course Code: ECN-201  
Full Marks: 50

---

There are Six questions. Answer any FIVE questions

1. (a) Define 'firm' and 'production' in context of economics. [3+2+5]  
(b) What are the meaning of 'inputs' and 'output' of a firm?  
(c) Discuss the 'law of diminishing marginal return.'
2. (a) Distinguish between economic cost and accounting cost. [6+4]  
(b) Describe the relations between/among different types of cost concepts used in production analysis.
3. (a) Distinguish between oligopoly and monopolistic form of market. [5+3+2]  
(b) Discuss the characteristics of a perfect competitive market.  
(c) What are forms of market of apartment industry in Dhaka city and cement industry in Bangladesh?
4. (a) Define 'market economy' and 'planned economy'? [3+2+5]  
(b) Cite examples of some of the public goods?  
(c) What is negative & positive externality? Discuss with examples.
5. (a) Define 'GDP' and 'GNP'. Which one is the better measure for the national income of Bangladesh? [4+3+3]  
(b) Distinguish between fiscal policy and monetary policy.  
(c) Give your opinion on the effects of fiscal policy and monetary policy on the civil engineering works of Bangladesh.
6. Write short notes on any FOUR of the followings [2.5\*4]
  - (a) Economy of scale;
  - (b) Return to scale;
  - (c) Inflation;
  - (d) Macroeconomics;
  - (e) Unemployment.

## The University of Asia Pacific

Final Examination, Fall 2009

Course No: HSS-101

Course Title: English Language I

Time- 3 hrs.

Total Marks- 100 (50)

Section –A (Answer any three from the following questions)

3x10=30

Q.1. Write a paragraph showing the differences between a zoo and a forest. (250 words)

Q.2. Describe a museum you have visited. (250 words)

Q.3. Write a letter to your friend requesting him/her to lend you some books. (250 words)

Q.4. Translate the following paragraph into English.

কয়েকদিন ধরে প্রচণ্ড গরম পড়েছিল। বিশ্ববিদ্যালয়ও ছিল বন্ধ। তাই সুমন সিংহাস্ত নিল সে কিছুদিন গ্রামের বাড়ীতে বেড়িয়ে আসবে। তাদের গ্রামের বাড়ীটা ছোট হলেও সুন্দর এবং গাছপালা দিয়ে ঘেরা। সেখানে তার দাদা দাদী এবং কিছু দূর সম্পর্কের আত্মীয় থাকেন। সেখানে পৌঁছে সুমন প্রথমেই ভেতরে গেল না বরং কিছুক্ষণ বাইরে দাঁড়িয়ে থেকে গাছপালাগুলো দেখল। এখানে আসতে সবসময়েই তার ভালো লাগে। সবুজ গাছপালা, তাজা শাকসব্জি, পাখির ডাক, সবকিছুই তার ভালো লাগে। তবে সবচেয়ে ভালো লাগে তার দাদা দাদীর সান্নিধ্য।

### Section-B

(Answer all the questions)

5. Read the following passage and answer the questions that follow.

#### *Advertising*

Advertising has become a very specialized activity in modern times. In the business world of today, supply is usually greater than demand. There is great competition between different manufacturers of the same kind of product to persuade customers to buy their own particular brand. They always have to remind the consumer of the name and the qualities of their product. They do this by advertising. The manufacturer advertises in the newspapers and on posters. He sometimes pays for songs about his product in commercial radio programmes. He employs attractive sales-girls to distribute samples of it. He organizes competitions, with prizes for the winners. He often advertises on the screens of local cinemas. Most important of all, in countries that have television he has advertisements put into programmes that will accept them. Manufacturers often spend large sums of money on advertisements. We buy a particular product because we think that it is the best. We usually think so because of the advertisements that say so. Some people never pause to ask themselves if the advertisements are telling the truth.

**A. Answer these questions. Do not write more than two sentences.**

**10**

- a) How many kinds of advertisements are mentioned in the passage? What are they?
- b) Why do manufacturers spend so much money on advertising?
- c) What do sales-girls do?
- d) Which do you think more effective, giving out samples or paying for television advertisements? Say why.
- e) Do you think that we buy goods because they are advertised? Why do you think so (or not)?

**B. Find words in the passage that give the meaning of these phrases:**

**5**

- a) the activity of telling people about products for sale
- b) the activity of providing things for sale
- c) the need to buy things.
- d) the efforts of one person to do better than another person
- e) radio programmes that accept money from advertisers

**Q.6. Write the homophones of any five of the following words and make sentences with the words and their homophones.**

**10**

Tail, sin, by, new, dear, inn, steal

**Q.7. Write two sentences with any five (ten sentences) of the following words giving their two different meanings.**

**10**

Stage, express, land, mark, over, foot, game

**Q.8. Punctuate the following sentences and write capital letters where necessary.**

**5**

- a. if you visit the trade fair youll see a lot of nicely decorated stalls
- b. swimming lessons are on mondays tuesdays and fridays
- c. in an interview today the mayor said we expect a large crowd for our summer festival
- d. have you read war and peace by tolstoy .
- e. brian lara is a famous cricketer from the west indies

**Q.9. Fill in the blanks with appropriate parts of speech. (any five)**

**10**

- a. The ----- (achieve) of the players depend on their ----- (perform).
- b. The ----- (invent) of science have made our life ----- (comfort).
- c. The ----- (friend) of the officer makes him a very ----- (love) character.

- d. She became ----- (fame) because of her ----- (diligent).  
 e. The ----- (industry) areas of our city are ----- (noise).  
 f. Our ----- (exist) on earth depends on our ----- (thought) use of modern technologies.

**Q. 10. Match the words from column-A with those of column-B according to vowel sound.** **5**

<u>A</u>	<u>B</u>
shrunk	chat
deep	soil
frown	brave
glue	skip
mars	knee
claim	scar
filthy	shut
foist	sly
pie	clue
craft	gown

**Q.11. The following extract has some misspelled words. Find them out and write them correctly.** **5**

I've had a busy schdule lately. I'm taking sking lessons! In the beginning it was awfully hard, but now I'm getting better. It's a good thing they have seperate classes for beginners.

Last night my mother and I brought the pizzas salad. She and my sister also organized games for the children. My brothers Jed and Nick offered to pripare hamburgers. They and My father set up a table with pickles, musterd, and tomatoe slices. We even had vanila ice cream for desert!

**Q.12. Add one prefix with any ten of the following words and make a sentence with each of the new words.** **10**

*Un-, under-, re-, dis-, for-, il-, mis-, over-, in-, en-, pre-, post-, ir-*

Fit, Appear, Hurt, New, Logic, Emphasize, Ground, Light, Pay, History, Regular, Convenient

(4) (5)

**The University of Asia Pacific**  
**Department of Architecture/ Business Admin/ CE/ CSE/ Pharmacy**  
**Final Examination: Fall 2009**

**Program: B Arch/ BBA/ B.Sc Engineering/ B Pharm**

Course Title: English Language II

Course Code: HSS 103

Credit: 3.00 (three)

Time: 3.00 Hours

Full Mark: 100 (50)

- 
1. Rewrite any **ten (10)** of the following sentences by using appropriate modal verbs: 10
- There is a possibility of his visiting my home.
  - We cannot but accept the fact.
  - I was in the habit of doing my exercises regularly.
  - He is able to speak English.
  - He is permitted to join us.
  - It is suggested that you take a good preparation for your examination.
  - I offer myself to assist you in doing this job.
  - I am obliged to go there by 5 o'clock.
  - You have the necessity to wash your car.
  - Shipon has no necessity to go there.
  - They did not get any permission to play football after their classes.
  - I advise you to do all your tasks on time.
2. Join any **ten (10)** of the following pairs of sentences with the given joining words (i.e., conjunctions or relative pronouns). Do not use the same joining word more than once: 10
- who, although, but, yet, which, that, because, not only...but also, since, when, therefore, so that*
- I met the man in the market. He was buying a shirt.
  - I will study regularly. I want to shine in life.
  - I trust his words. He is truthful.
  - I will complete my studies. I will join a job.
  - The man called the police. He had some problems.
  - He sells fruits. He sells vegetables.
  - We tried our best. We failed to rescue them.
  - I can't do the exercises. They are tricky.
  - We live in this flat. This needs to be painted.
  - Zishan wants to be a good programmer. He does not practice well.
  - The book is difficult to understand. People read it.
  - He'll give me the book. I need it very much.
3. Write one synonym and one antonym of any **five (5)** of the following words and make sentences with these synonyms and antonyms. 10 + 10 = 20
- (10 marks for producing the synonyms & antonyms + 10 marks for making sentences)*
- |                |                |               |
|----------------|----------------|---------------|
| a) Counterfeit | b) Pessimistic | c) Brutal     |
| d) Assist      | e) Durable     | f) Deliberate |
| g) Zenith      |                |               |
4. Write an application to the Head of your Department seeking help to organize an English Club. 10

5. UAP will participate in the 'Inter University Debate Championship 2010'. As the convener of UAP Debating Club, write a memorandum to other members of the club to this effect. **10**

6. UAP has recently arranged its annual cultural programme. As a reporter of a daily newspaper, write a news-report on the event for publication in your newspaper. **10**

7. Write single sentence definitions any **five (5)** of the following words: **10**

- |                          |                          |                      |
|--------------------------|--------------------------|----------------------|
| a) Flexible (synonym)    | b) University (negation) | c) Precise (synonym) |
| d) Television (function) | e) Octopus (description) | f) Lemonade (class)  |
| g) Internet (function)   |                          |                      |

8. Write a paragraph on any **one (1)** of the followings (word limit 130 words) **10**

- |                                |                  |                     |
|--------------------------------|------------------|---------------------|
| a) A Day that I Still Remember | b) Reading Books | c) Student Politics |
|--------------------------------|------------------|---------------------|

9. The chart below shows the amount of leisure time enjoyed by men and women of different employment status. Describe and analyze the information available in the chart in your own words. **10**

**Leisure time in a typical week: by sex and employment status, 1998 - 99**

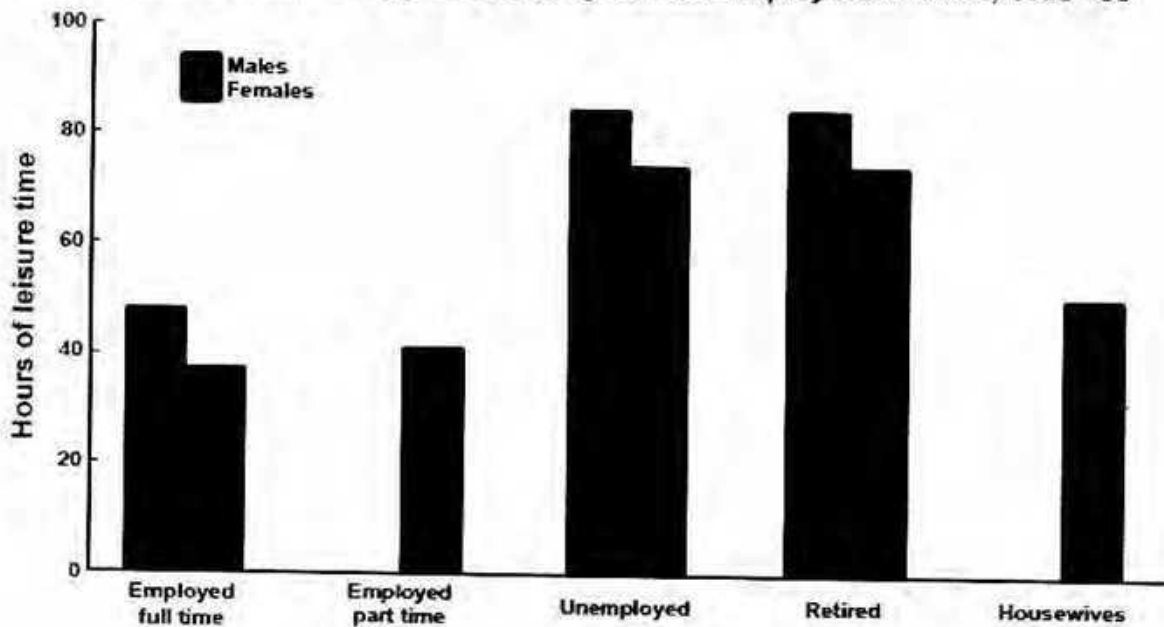

**The University of Asia Pacific**  
**The Department of Interdepartmental Courses**  
**Semester Final Examination, Fall 2009**

**Programme: BArch, BBA, BSc Engineering (CE, CSE, EEE) and BPharm**

**Course Title: Bangladesh Studies: Society and Culture**      **Course Code: HSS 111(a)**  
**Credit: 2.00**      **HSS 211 (a) [for CE]**

**Time: 2 hours**

**Full Marks: 50**

**All Questions are of equal value**

**Answer ANY FIVE of the following**

1. Briefly discuss on the branches of sociology.
2. Define Social Stratification. How do you relate ascribed and achieved status with class and feudal estate?
3. Discuss on the social stratification pattern of urban society of Bangladesh.
4. Define economic institutions. What are the features of industrial societies? Discuss.
5. Define political institutions. What are the types of government? Discuss on any two of them.
6. What is the situation of urbanization in Third World Countries? Briefly discuss.
7. Write short notes on any TWO of the following
  - a. Functions of Economic Institutions
  - b. Functions of Government
  - c. Caste System



**The University of Asia Pacific**  
**Department of Interdepartmental Courses**

Semester Final Examination, Fall 2009

Programme: BBA, BSc Engineering (CE, CSE, EEE) and BPharm

Course Title: Bangladesh Studies: History of Bangladesh      Course Code: HSS 111(b)  
Credit: 2.00      HSS 211 (b) [for CE]

Time: 2 hours

Full Marks: 50

All Questions are of equal value.

Answer any five of the following

1. Who was Iliyas Shah? How did he unify the whole of Bengal?
2. Write short note on the Bara-Bhuiyans.
3. Discuss the causes and results of the battle of Palashi.
4. Briefly narrate Raja Rammohun Roy's social reforms in the 19<sup>th</sup> century Bengal.
5. What were the causes behind the partition of Bengal of 1905? Why did the Hindu elites oppose it?
6. Describe briefly the language movement of 1952.
7. What was the Six-point programme of 1966? What was its effect on the emergence of Bangladesh?

**The University of Asia Pacific**  
**Department of Interdepartmental Courses**  
**Semester Final Examination Fall 2009**  
**Program: B.Sc. Engineering (CE)**

**Course Title: MATH-I**

**Course Code: MTH-101**

**Credit: 3.00**

**Time: 3 hr**

**Full Marks: 50**

**Group: A**

**Answer any one of the following:**

**10**

1. (a) Find the radius of curvature of the parabola  $y^2 = 4x$  at the origin (0,0).  
(b) Find the equation of the circle of curvature at the point (3,1) on the curve

$$y = x^2 - 6x + 10.$$

2. Work out the Integrals (i)  $\int \frac{x^2 + 4}{x^2 + 2x + 3} dx$  and (ii)  $\int \frac{dx}{x^2(a + bx)^2}$

**Group B**

**Answer any Five of the following:**

**5×8=40**

1. Work out the Integrals (i)  $\int \frac{dx}{x(a + bx^n)}$ , (ii)  $\int \frac{dx}{\sqrt{(x - \alpha)(\beta - x)}}$  where  $\beta > \alpha$

2. Evaluate (i)  $\int_0^1 \cot^{-1}(1 - x + x^2) dx$  and (ii)  $\int_0^{\pi/2} \frac{x dx}{\sin x + \cos x}$ ;

3. (a) Write down the definition of Gamma and Beta functions and

Prove that  $\Gamma(\frac{1}{2}) = 2 \int_0^{\infty} e^{-x^2} dx = \sqrt{\pi}$ .

(b) Show that 
$$\int_0^{\pi/2} \frac{d\phi}{\sqrt{1 - \frac{1}{2} \sin^2 \phi}} = \frac{[\Gamma(\frac{1}{4})]^2}{4\sqrt{\pi}}$$

4. (a) Find the volume of tetrahedron formed by the plane  $\frac{x}{3} + \frac{y}{2} + \frac{z}{4} = 1$  and the coordinate planes using triple integral.
- (b) Find the volume of solid bounded above by the sphere  $x^2 + y^2 + z^2 = 25$ , bounded below by the xy-plane and having the cylinder  $x^2 + y^2 = 9$  as side wall.
5. (a) Sketch the graph and find the area bounded by the curve  $r = 2(1 + \cos\theta)$ .
- (b) Sketch the region bounded by the graphs of  $y^2 = 4x$  and  $y = 2x - 4$ . Then find the area of the region by integration
6. (a) Find the volume of solid formed by the revolution of the area bounded by the graphs of  $y = x^2$ ,  $y = 0$  and  $x = 2$  about x-axis.
- (b) Evaluate  $\iint_R [2a^2 - 2a(x + y) - (x^2 + y^2)] dy dx$ , the region,  $R$ , of integration being the circle  $(x + a)^2 + (y + a)^2 = 4a^2$ .

**THE UNIVERSITY OF ASIA PACIFIC**  
**Department of Interdepartmental Courses**  
**Final Examination Fall -2009**  
**Program: B.Sc. Engineering (CE)**

**Course Title: Math-II**  
**Time: 3.00 Hrs.**

**Course Code: MTH-103**

**Credit:3.00**  
**Full Marks: 50**

**Group-A**

**Answer any one of the followings:**

**1×10 = 10**

1. If  $\vec{A} = (3x^2+6y)\hat{i} - 14yz\hat{j} + 20xz^2\hat{k}$ , evaluate  $\int_C \vec{A} \cdot d\vec{r}$  from (0,0,0) to (1,1,1) along

the following paths C:

a)  $x = t, y = t^2, z = t^3$

b) the straight lines from (0,0,0) to (1,0,0), then to (1,1,0) and then to (1,1,1)

c) the straight line joining (0,0,0) and (2,2,1).

2. Define Quadric Surfaces. Solve the following equation:

$$F(x,y,z) = 11y^2 + 14yz + 8zx + 14xy - 6x - 16y + 2z - 2 = 0$$

**Group-B**

**Answer any five of the followings:**

**5×8 = 40**

1. a) Define plane. Prove that general equation of the first degree in x, y, z represents a Plane.

b) Find the equation of the plane through the points (2,2,1) and (9,3,6) and perpendicular to the plane  $2x + 6y + 6z = 9$

2. Find the magnitude and the equations of the line of shortest distance between the lines

$$\frac{x-8}{3} = \frac{y+9}{-16} = \frac{z-10}{7} \text{ and } \frac{x-15}{3} = \frac{y-29}{8} = \frac{z-5}{-5}$$

3. a) Define sphere. Find the equation of the tangent plane to a sphere.

b) Find the equation of the sphere whose centre is ( 2, 2, 3) and radius is 9.

c) Find the equation of the sphere passing through the origin and also the points (0,1,-1) (-1,2,0), (1,2,3).

4. a) Find the symmetrical form of the equation of a line  $x + y + z + 1 = 0 = 4x + y - 2z - 2$ .

b) Find the ratio in which the yz-plane and zx-plane divides the joints of the points (-2,4,7) and (3,-5,8).

5. a) Find the angles which the vector  $\vec{A} = 3\vec{i} - 6\vec{j} + 2\vec{k}$  makes with the co-ordinate axes.

b) Prove that the area of a parallelogram with sides  $\vec{A}$  and  $\vec{B}$  is  $|\vec{A} \times \vec{B}|$ .

c) Write down the laws of dot and cross Product.

6. a) Define direction Cosines of a line and direction ratios.

b) Establish the relation  $\sin^2\alpha + \sin^2\beta + \sin^2\gamma = 2$

**THE UNIVERSITY OF ASIA PACIFIC**  
**Department of Interdepartmental Courses**  
**Final Examination 'Fall-2009**  
**Program: B.Sc. Engineering (CE)**

**Course Title: Math-III**  
**Time: 3.00 Hours**

**Course Code: MTH-201**

**Credit: 3.00**  
**Full Marks: 50**

**Group-A**

**There are Six questions, Answer any 05(Five) of the following questions: 40**

Q.1. (a) Prove that  $\mathbb{R}^2$  is a vector space.

Define linear mapping. Show that the mapping  $T$  is not linear where  
 $T: \mathbb{R}^2 \rightarrow \mathbb{R}$  defined by  $T(x, y) = xy$ .

(b) Let  $T: V_3(\mathbb{R}) \rightarrow V_3(\mathbb{R})$  be a linear mapping defined by

$T(x, y, z) = (x, y-z, x+z)$ . Find a basis and dimension of the  
(i) Image of  $T$  and (ii) Kernel of  $T$ .

Q.2. Find all eigenvalues and corresponding eigenvectors of  $A$ . Also find an invertible matrix  $P$  such that  $P^{-1}AP$  is diagonal where

$$A = \begin{pmatrix} 1 & 4 \\ 2 & 3 \end{pmatrix}.$$

Q.3. Verify that the matrix representation of the linear operator  $T: \mathbb{R}^2 \rightarrow \mathbb{R}^2$  defined by  $T(x, y) = (2x - 3y, x + y)$  with respect to the basis  $\{f_1 = (1, 2), f_2 = (2, 3)\}$  verify that  $[T]_f [v]_f = [T(v)]_f, \forall v \in \mathbb{R}^2$ .

Q.4. State Cayley-Hamilton theorem. Prove the Cayley-Hamilton theorem.

hence find the inverse of  $A$  (using by C-H theorem) where  $A = \begin{pmatrix} 2 & -1 & 1 \\ 1 & 0 & 3 \\ 0 & 0 & 2 \end{pmatrix}$ .

Q.5. Define Mathematical Expectation. If a coin tossed 3 times.

Find the Mathematical Expectation for the number of tail and variance.

Also find  $E(x^2)$  and  $E(2x^2 - 2x + 5)$ .

Q.6. A box contains 4 white , 5 red and 6 green balls . Three balls are drawn at random

Find the probability of getting (i) all are red. (ii) green 2 balls. (iii) different colors.  
(iv) at least 2 red balls.

**Group-B**

Q.7. Either

10

Write short notes:

- (i) Moments.
- (ii) Kurtosis
- (iii) Skewness
- (iv) Quartile Deviation
- (v) Variance.

**Or**

(i) Find the coefficient of skewness, kurtosis and give comments for 25,15,23,27,25,23,20.

(ii) A card is drawn from a pack of 52 cards. Find the probability of getting  
(i) King. (ii) Hearts (iii) Hearts or spade (iv) Hearts or ace.

**The University of Asia Pacific**  
**Department of Interdepartmental Courses**  
**Final Examination Fall- 2009**  
**Program: B.Sc Engineering (CSE/CE/ARCH)**

Course Title: Physics I  
 Time: 3.00 Hours

Course Code: PHY-101

Credit: 3.00  
 Full Mark: 50

There are **Eight** Questions. Answer any **five** from **group A** and **one** from **group B**

**Group A**

1. (a) State and explain Stoke's law and prove that  $\eta = \frac{2r^2(\rho - \sigma)g}{9v}$ , where the terms have their usual meanings. 6
- (b) Find the limiting velocity of a rain drop whose diameter is  $2 \times 10^{-2}$  m. Density of air relative to water =  $1.3 \times 10^{-4}$ , co-efficient of viscosity of air =  $1.81 \times 10^{-5}$  S.I. units and density of water =  $4 \times 10^3$  kg/m<sup>3</sup>. 2
2. (a) State and explain the Bernoulli's theorem and prove that  $\frac{v^2}{2} + gh + \frac{p}{\rho} = \text{constant}$ , where the terms have their meanings. 5
- (b) Two equal drops of water (surface tension T), each of radius r, are falling through air (viscosity  $\eta$ ) with a steady velocity v. If the two drops coalesce to form a bigger drop, (i) compute the energy released (ii) find the new velocity of fall. 3
3. (a) What is Newton's ring? 1
- (b) Find the radius of the bright and dark Newton's ring formed by reflection of light. 5
- (c) A thin equiconvex lens of focal length 4 metres and refractive index 1.5 rests on and in contact with an optical flat, and using light of wavelength  $5460 \text{ \AA}$ , Newton's rings are viewed normally by reflection. What is the diameter of the 5 th bright ring? 2
4. (a) What are transverse and longitudinal waves? 1
- (b) Show that the differential equation of a progressive wave is  $\frac{d^2y}{dt^2} = v^2 \frac{d^2y}{dx^2}$ , where the symbols have their usual meanings. 5
- (c) A particle executes simple harmonic motion given by the equation  $y = 12 \sin\left(\frac{2\pi t}{10} + \frac{\pi}{4}\right)$ , calculate (i) amplitude, (ii) frequency, (iii) epoch, (iv) acceleration at  $t = 5$  s. 2

5. (a) Derive the Laplace's correction to Newton's formula,  $V = \sqrt{\frac{\gamma P}{\rho}}$ , where the symbols have their usual meanings. 6
- (b) Find the velocity of sound in a gas according to Newton's formula. 2
6. (a) What is Doppler effect? 1
- (b) Derive the equation of Doppler effect when source in motion and observer at rest. 5
- (c) A motor car sounding a horn at a frequency of 100 Hz moves away from a stationary observer towards a rigid flat wall with a velocity of 36 km/hr. How many beats per second will be heard by the observer? The velocity of sound in air at room temperature = 350 ms<sup>-1</sup> 2

### Group B

7. (a) What is called cantilever? Prove that depression  $y = \frac{Wl^3}{3YI_g}$ , where the terms have their usual meanings. 7
- (b) A uniform rod of length 3.5 m is clamped horizontally at one end. A weight of 4.5 kg is attached at the free end. Calculate the depression  $y$  at the mid point of the rod. The diameter of the rod is 0.06 m. ( $Y = 3 \times 10^{12}$  n/m<sup>2</sup>) 3
8. (a) What is Lissajous' figure? Show that the equation of the composition of two simple harmonic vibrations of equal time periods acting at right angles is  $\frac{x^2}{a^2} + \frac{y^2}{b^2} - \frac{2xy}{ab} \cos \alpha = \sin^2 \alpha$ , where the symbols have their usual meanings. 6
- (b) Draw different Lissajous figures stating their conditions of formation. 2
- (c) In an experiment to obtain Lissajous figures, one tuning fork is of frequency 250 Hz and a circular figure occurs after every five seconds. What deductions may be made about the frequency of the other tuning fork. 2



## Section C

Read the following article and write the following:

- a) Summary of the study which should include purpose, methodology, findings and its limitations. (35)
- b) General discussion on the findings. (40)

### One crisis after another

#### Municipal experiences of severe storm in the shadow of the tsunami

##### Introduction

On the January 8, 2005, the southern part of Sweden was hit by a severe storm with local hurricanes. Given the name Gudrun, this storm was the worst in 100 years. During a few hours, 22 million m<sup>2</sup> of timber fell, about 18 percent of the total wood supply in the area. Roads were blocked, and initially approximately 300,000 people were without electricity, water and telecommunications. In some areas these conditions continued for up to eight weeks. The storm occurred at the coldest time of year and only two weeks after the tsunami in Southeast Asia (December 26, 2004). The consequences of the tsunami had deeply affected Swedish society, since over 20,000 Swedish tourists were in the region, and 543 Swedes were later confirmed missing or dead (Stroˆmbaˆck and Nord, 2006). Occurring in close succession, these two events put crisis management skills to the test under exceptional circumstances. This study focuses on experiences from chief officers and politicians in municipalities affected by the storm. Crisis management legislation and practice is in a process of change in many countries. Such changes include initiatives to simplify regulatory systems, as in Norway (Hovden, 2004); moves towards greater decentralization, as in France (Lagadec, 2002); or shifts in focus, such as that from local to domestic security in the USA (Stehr, 2007). The recent years have been a period of new legislation also in Sweden, resulting in greater responsibility at the municipal level. New approaches in crisis management also place new demands on managers (McEntire and Myers, 2004; Robert and Lajtha, 2002; Stehr, 2007). There are, however, as yet very little empirical data to indicate how managers are dealing with these new responsibilities, or what factors influence their choices and actions (Drabek, 2005). Thus the experiences of local managers and politicians faced with the storm Gudrun are of interest in several ways.

In comparison with many other countries, Sweden has limited experience of dealing with major natural disasters. In the case of Gudrun, a number of municipalities with different experiences and vulnerabilities were hit by the storm. This provided an opportunity to study local differences in how similar situations could be interpreted and handled. The purpose of the study was to study these issues and to analyze the problems and demands that managers faced over a long period of time.

##### Method

The study was conducted using qualitative interviews and a grounded theory approach (Glaser and Strauss, 1967).

##### Sample

The municipalities and managers comprising the study sample were strategically selected. The three municipalities selected had all been seriously affected by Gudrun, but varied as to previous crisis experiences. One municipality had no experience, another had several previous events (storm and flooding) and the third had somewhat less experience. The municipalities have between 18,000 and 30,000 inhabitants. The respondents had all been involved in dealing with the consequences of Gudrun, but represented different everyday roles and functions. The respondents were selected using the snowball technique (Taylor and Bogdan, 1998). In total 19 heads, managers and politicians were interviewed: three

chief municipal managers, two heads of social service, one deputy head of social service, three rescue service chiefs, three heads of technical offices, two safety managers, one deputy head of property management department, one IT chief and three politicians. Nine were women.

### **Procedure**

The prospective informants were contacted by e-mail and/or telephone. Before the interviews they were informed about the purpose and procedures of the study, that participation was voluntary and that confidentiality would be closely regarded. The interviewers (two of the authors) asked open-ended questions with individual follow-up questions. The guide was developed as a mind map and comprised six themes:

- (1) Dealing with the event. (Questions illustrated by: describe what happened and your own work related to the tsunami and Gudrun).
- (2) Personal role. (Differences from normal everyday role?)
- (3) Preparedness. (More or less prepared for?)
- (4) Previous experience. (Personal, municipal, influences?)
- (5) Lessons learned. (Positive and negative?)
- (6) Experience of dealing with two events partly parallel. (Strengths and drawbacks?)

The interviews took between one to two hours and were conducted at the respondent's work place. All were tape-recorded, with one exception (documented from notes).

### **Analysis of data**

All taped interviews were transcribed verbatim. Data protocols were read in their entirety to provide a total picture of every respondent. The protocols were then analysed according to guidelines for the comparative method introduced by Glaser and Strauss (1967). The first step was a so-called open coding. Every line in a protocol was read carefully to break down and identify respondents' descriptions of their own thoughts, feelings and activities. One example of a code was "I put a lot on her (my wife) shoulders, I should have been there and helped her out with this but it didn't turn out that way". This statement was sorted under the code double loyalty. The codes were continuously compared with each other, so that codes with the same meaning should have the same code name. In the next step, codes were sorted into different categories. Double loyalty was sorted under the category internal demands. Here it was important to compare and check the codes and categories with data. The third step was to find joint overall categories using the constant comparative method. The category internal demands was here sorted under the theme personal strain and stress. In practice the process was not strictly sequential, the comparisons between data, codes and categories were done iteratively. Memory notes were also taken continuously during the analysis. The comparison between codes, categories and themes generated a hypothetical model that is presented in the results section. The model is presented first, followed by descriptions of the different themes.

## **Results**

### **The model**

Data analysis generated a model describing factors significantly affecting the reactions and decisions of the managers. Central in the model is an evaluation sphere, which describes basic value conflicts and tensions revealed in the interview data. Three main categories were identified:

- (1) the tension between everyday work and crisis needs;
- (2) conflicts in assessments of the relevance/applicability of legislation and established practice; and
- (3) tension in assessing human vulnerability versus coping resources.

This evaluation sphere is in turn influenced by three different areas, comprising:

- (1) characteristics of the leaders themselves;
- (2) characteristics of the crisis; and
- (3) the societal context within which the event occurred.

Decisions and actions can be seen as being formed from the evaluation sphere and the influencing factors. The model is shown in Figure 1.

### Evaluation sphere: conflicts and tension

This sphere identified areas of tension or conflict underlying the respondents' descriptions of different crisis-related problems and priorities.

**Everyday work versus crisis needs.** The consequences of the storm demanded intense effort during several weeks. Many people were in acute need of help, but still the normal routines had to continue. The tension between everyday principles and crisis demands produced priority dilemmas:

[...] we are trying to give people food and water. – Yes, but what shall we do about the annual report that should be ready by noon? Changing situational demands meant that managers were forced to repeatedly switch between everyday routines and crisis measures over a long period of time.

**Legislation and practice: support or hindrance.** A second area of tension concerned laws, regulations and established practice with regard to whether or not these provided sufficient and relevant support in the present situation. Here differences appear between the municipalities in the study. Thus in one municipality managers tended to perceive the legislative system as insufficient and limited, and it was therefore deemed acceptable to not always follow regulations:

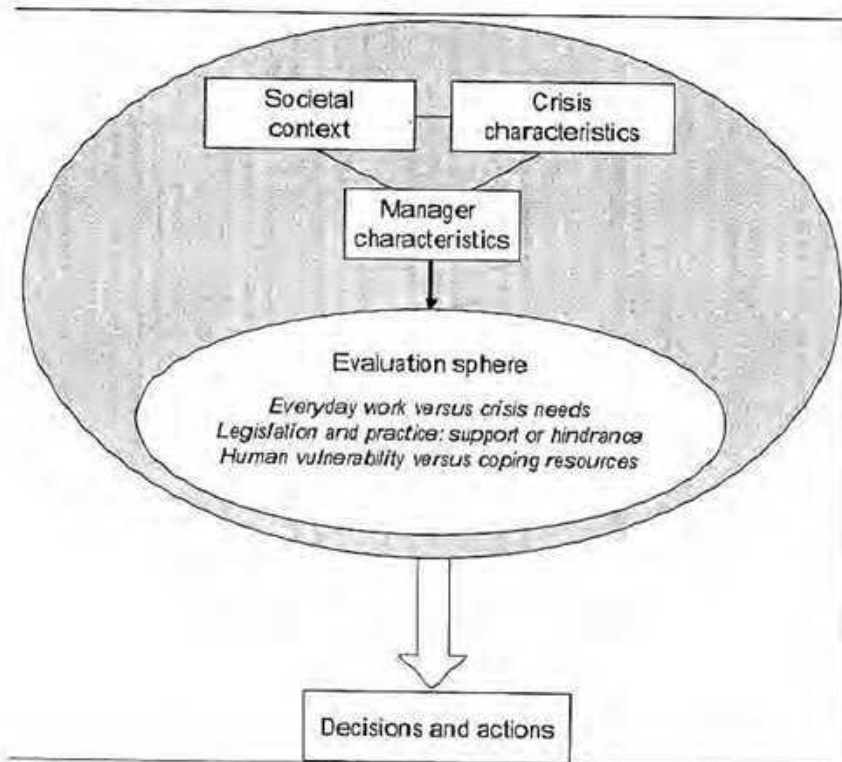

Figure.1

Some decisions have actually been in conflict with the local government law, because we have not treated everybody 100 percent the same since they (people) do have such different needs. But in another municipality rules and regulations were regarded as an absolute framework on which to base decisions.

**Vulnerability versus coping resources.** This third area of tension emanated from assessments of how vulnerable people actually were, and values concerning the responsibilities and coping resources of the individual. Again the municipalities differ in their assessments: I know that municipality [NN] supplied blankets and stuff like that, but our view is that our citizens were able to buy blankets themselves.

### Influencing factors

As shown in the model, the evaluations of the managers are influenced by factors related to the actors themselves, to the event and to the broader societal context.

**Manager characteristics.** Clearly respondents' position or role influences how they perceive demands in dealing with crisis situations. For example, rescue chiefs emphasize quite different aspects from heads of

social offices. However, the analysis revealed two other actor-related characteristics of significance for how the event was perceived.

Personal experience of the force of the storm was one factor. Respondents were themselves affected by the material and emotional consequences:

At home it was devastation everywhere and you couldn't go anywhere, you could not get pass the courtyard. The cowshed had moved 40 centimeters [ . . . ]

Their own experience meant that respondents wanted others to fully understand, in particular decision makers:

[ . . . ] they should come down here, see it, feel it [ . . . ].

Previous experiences were a second important actor-related factor. These included experience from earlier crises, exercises, etc. Previous experiences of crisis could influence threat identification, mobilization: ". . . we got started quickly and so on, thanks to the flood (experience)", and mental preparedness. Still, there was a lack of mental preparedness for an event of these dimensions: A storm – you think of it as some trees falling . . . but nobody had imagined this level. Although some managers pointed out that they had learned a lot from exercises, these could not be compared at all with the situation after the storm.

**Crisis characteristics.** The critical aspects of an event can be perceived in many ways. In the descriptions of dealing with Gudrun, two aspects are particularly dominant. One concerns the uncertainty and the dynamic nature of the situation. The second focuses on the physical and mental effects on those affected.

The period after the storm was characterized by uncertainty and potential new problems. Three elements in particular could contribute to the situation rapidly becoming worse:

(1) the temperature was mild for the time of the year and it could become much colder at any time, thereby increasing the vulnerability of already affected groups;

(2) there was concern about certain reactions among people, as cases of suicide among forest owners were being reported; and

(3) there was an increasing risk of accidents among the hard-pressed municipal employees and forestry workers.

The way in which the storm revealed vulnerabilities and elicited different reactions was a second dominating crisis characterization. Respondents' identification of particular vulnerability could be related to several factors. One was occupation, where farmers and forest owners were most hard-hit:

[ . . . ] many people here are forest owners and could see their whole life demolished.

Another factor was social situation, for example families with small children. Previous experiences were also of importance. Elderly people coped better than expected, while people who had moved from cities to the countryside had difficulties. Involvement could also be a vulnerability factor. Thus citizens who on their own initiative supported others could be a risk group.

Vulnerability differed, as did reactions. The managers describe sharp contrasts in the way people reacted. Some reactions were turned inward, as for example apathy, resignation and depression. Other reactions were more extrovert, such as irritation and anger. Managers could be faced with unrealistic demands, for example to pay someone's hotel bill and increased cell phone bills. Other reflections concern the positive reactions among people; helping each other, putting old quarrels aside, solving problems themselves instead of burdening the municipal staff, etc.

### **Societal context**

Each crisis occurs within a societal context that creates a framework for the way in which the event is perceived and evaluated. This context can be structural, in the form of legislation, rules and principles, but can also be related to specific national or regional experiences and current societal issues. In the data from the management of the Gudrun storm, the implications of dealing with this event only a fortnight after the Southeast Asian tsunami is perhaps the most dominant contextual factor. This had several implications. On the operative side there were positive aspects, in that regional and municipal crisis support and information systems were already alerted, in preparation to receive possible survivors returning home. The emotional aspects were complex. In comparison with a disaster of such magnitude the effects of the storm could be perceived as less serious, giving a sense of perspective on practical problems.

But the images from the tsunami reports also contributed to an atmosphere of uncertainty:

[ . . . ] the tsunami started a feeling in us that anything can happen, a sense of insecurity. You never know from one day to the next what can happen [ . . . ]

Working in the shadow of the tsunami could also be frustrating; managers experienced a lack of interest from central authorities and from the national media.

### **Decisions and actions**

The lower section of the model describes crisis decisions and actions, which can be seen as outcomes influenced by the evaluations and by the influencing factors. Five different categories appeared.

**Leadership issues.** The conflict between everyday and crisis conditions and the tension in assessment of the relevance of rules and practice form a basis for how the respondents discuss their own role and the demands on crisis management. Two different ways of perceiving personal role appear: either as a natural progression from the ordinary everyday role, or as different and formed by the situational demands and public needs. The latter view is related to accountability, as expressed by one respondent as:

[...] I have got the opportunity to become chief here in order that I can give the citizens what they need.

**Co-operation and communication.** The storm affected a large region encompassing many municipalities, making co-operation and co-ordination at all levels necessary. Co-operation was developed between municipalities, the national defense, volunteer groups, media and private companies. Reflections regarding co-operation include both positive and negative views.

Collaboration appears to have been facilitated when the demands of the crisis, and the balance between vulnerability and coping ability were interpreted in similar ways by different actors. A common picture of the situation and lack of prestige were seen as important for smooth operation.

Negative comments regarding co-operation could concern differences in assessments of needs. For example, in one municipality, people received help from the authorities to install their emergency power supply, but not in the other. Such differences could result in dissatisfaction and confusion among both personnel and the public. Differing assessments of how vulnerable people actually were could also cause problems in cooperation. On the one hand, operative personnel from rescue services and national defense tended to have a more protective and action-oriented attitude towards the public, while social service officers rather tended to emphasize individual rights, for example in choosing whether or not to leave one's home:

[...] the individual [must] have the opportunity to choose. We can't just bulldoze over them.

Some rivalry arose between municipalities and was manifested for example at meetings with the County Administrative Board:

[...] a race about who has done most and who had most meetings and all that. Criticism of media mainly concerned that they were too passive initially, since the tsunami disaster absorbed all attention. The managers mention that they were relieved that local media prioritized their task as providers of information rather than as critics, but also that they gave positive reports of the crisis management. The social service personnel particularly were honored by a double-page article headed "The heroes of the storm."

**Support to the public.** After the storm there was an overwhelming need for support to citizens. Natural social supportive networks were overtaxed, with so many people affected. The municipal managers faced difficult decisions assessing needs and differentiating support. Here tensions outlined in the evaluation sphere were often apparent.

Assessing actual needs could be difficult:

[...] who has a real need and who is [just] shouting? One view focused on the seriousness of the situation and the need to do everything possible to help people, while others took the cooler view that "... there are no deaths yet" and that people were capable of dealing with the situation themselves. Similarly, laws could be invoked as arguments both for extending extra support to certain groups and for limiting support and placing more responsibility on individuals.

Priorities could be based on assessments of material, but also psychological needs. This could for example be a reason for holding all schools in an area open:

[...] for psychological reasons ... we could not have one school closed. Psychosocial considerations were also important in determining what kind of help people might need and from whom they would accept it.

**Support to personnel.** Municipal personnel were under pressure in a number of ways. Many had an increased workload, had to perform tasks that might involve risks and they could also be affected personally. Responsibilities as a leader could involve assessing how far it was justified to require somebody to do extra work besides ordinary tasks, or whether to follow or deviate from rules and regulations. One example is prioritization between the safety of personnel and the fulfillment of responsibilities:

One of our fire fighters was injured seriously and got a tree over himself [ . . . ] Then we started to assign priorities to which missions we should go to. Shortly after the storm, managers began to realize the need for a sustainable organization and support to the staff. This could take the form of redistribution of personnel, release from ordinary tasks and clarifying to the staff that it was acceptable to prioritize differently;

[ . . . ] you must focus on the most important, and it is not a catastrophe if some protocols are not written.

Psychosocial support strategies could include attention, encouragement, support for individual initiatives and humor. But there was also a need for more qualified support from the occupational health service and for external crisis support.

**Manager strain and stress.** Managers were under strain because of an increased workload and the need to make many decisions involving people's health and safety. Meeting the needs and reactions from the public could be taxing, and when so many people were affected, their problems came very close to the respondents:

[ . . . ] it got under my skin [ . . . ]. But respondents could not concentrate only on the crisis, they also had to think about the economic aspects:

[ . . . ] money, money, money, we need to take control over the money. It can't cost too much [ . . . ].

Respondents experienced further pressure because many were also affected themselves, which resulted in a loyalty conflict between family and work:

I felt the first days that I should be here and I should be there in reality. Respondents used different strategies to cope with this strain. Personal strategies included: taking care of physical health by eating well, training and sleeping; priority of free time, to be home and do ordinary things "[ . . . ] gave the kids a good night hug [ . . . ]"; and delegation. Support from colleagues and personnel were also important to cope with stress.

**The University of Asia Pacific**  
**Department of Civil Engineering**  
**Grade Sheet for Fall 2009**

Course No: CE 6006

Course Title: Environmental Hazard & Disaster Management

Credit Hour: 3.0

Course Teacher: Dr. M. R. Kabir

Sl	Registration	Name	Marks Obtained				Grade
			Class Asses. (30%)	Mid-Term (20%)	Final (50%)	Total (100%)	
1	09215001	Kazi Emdadul Hoque	23	9.5	29	62	B
2	09215002	Md. Abdul Kader	8	12.5	26.7	47	C
3	09215004	Md. Mahafizul Hassan	22	11	29.7	63	B
4	09215005	K. M. Abdullah Al Mamun	10	8	27	45	C
5	09215006	Mohd. Elias Hossain Sarker	22	14	28.7	65	B+
6	09215007	Md. Babul Miah	21.5	10.5	23	55	B-
7	09215008	Kazi Mohammad Mohiuddin	5	8.5	13	27	F
8	09215009	Bishwajit Roy	21.5	13	25.3	60	B
9	09215010	Mohammad Moniruzzaman	23.5	11	22.3	57	B-
10	09215011	Hare Krishna Das	22.5	5	18.3	46	C
11	09215012	Sudhir Kumar Sutradhar	21	15.5	20	57	B-
12	09215013	Md. Habibur Rahman Chowdhury	20	5	18	43	D
13	09215014	Mohammad Mahtab Uddin Patwary	5	8	33.7	47	C
14	09215015	Md. Monirul Islam	23	11.5	25	60	B
15	09215016	Md. Abdur Rashed Molliak	23	11.5	26.3	61	B
16	09215018	Syed Sharfuddin Ahmed	22.5	13	27	63	B
17	09215019	Nafis Sarwar	24.5	15	40.3	80	A+
18	09215020	Md. Motaleb Hossain Akand	22	15.5	27	65	B+
19	09215021	Muhammad Abul Monsur	23.5	13.5	29.3	66	B+
20	09215022	Ranaduir Kumar Das	26	16.5	39.3	82	A+
21	09215023	Md. Hasan Ali	23	9.5	18.7	51	C+
22	09215024	Debasish Saha	23	12.5	22	58	B-

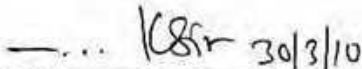
  
 Signature of the Examiner  
 Dr. M. R. Kabir  
 Professor

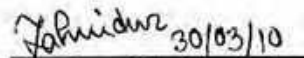
  
 Signature of the Scrutinizer  
 Md. Tahmidur Rahman  
 Lecturer

  
 Signature of the Head  
 Dr. Md. Tarek Uddin  
 Professor and Head

The University of Asia Pacific  
 Department of Civil Engineering  
 Final Examination Fall 2009  
 Program: Master in Civil Engineering

Course Title: Advance Design of Concrete Structure  
 Time: 3 Hours

Course Code: CE-6108  
 Full Marks=100

*There are Ten questions. Answer Eight questions and question 1, 2.3 and 4 are compulsory*

- 1.(a) A reinforced concrete beam can fail in pure flexure in three possible ways. Describe each failure mode briefly.
- (b) What do you mean "balanced steel ratio"? What is the purpose of the ACI provision requiring maximum and minimum steel ratio of flexural steel?
- (c) Describe the two modes of shear failure in normal proportion beam?  
 Explain how the magnitude of bending moment influences shear strength?
- (d) What parameter is to be considered if the depth of a beam exceed 3 ft.?  
 Explain the reason.
- 2.(a) Explain Bernoulli Hypothesis and St. Venant's principle. Differentiate the behavior between deep beam and normal proportion beam?
- (b) Sketch the "B" and "D" region for the following cases
  - i. Bracket extending from a column
  - ii. In a pile cap
  - iii. In a simple supported beam at middle third loading condition and
  - iv. In a simply supported beam with rectangular opening at the centre.
3. (a) What is the difference between short and long column? Give the reasons why the ACI code requires a minimum and maximum area of steel in column design.
- (b) What is the effective length of a column? What is the difference between a braced and an unbraced column? Write the ACI criteria between sway versus non-sway frames?
4. (a) What is the difference between Silo and Bunker? Explain with sketches the discharge flow characteristic of storage material.
- (b) Explain why flexural shear is critical at a distance  $d$  and punching shear at a distance  $d/2$  from the face of the support.
5. The four side simply supported slab carries a total service load  $w$ . Find out the sharing load in two mutually perpendicular direction according to deformational compatibility for the following cases-
  - a) Two side edges are equal
  - b) Longer side is twice than shorter side.

6. Draw the column strength diagram for the given section and reinforcement about its strong axis considering  $f'_c = 3$  ksi and  $f_y = 60$  ksi.-

No of rebar 4  
 Dia. of Rebar = 25mm  
 Column Size 12"X20"

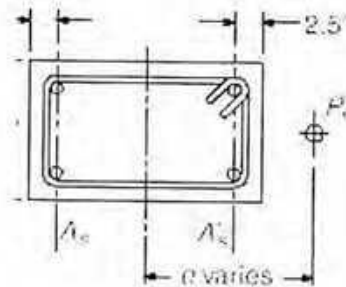

7. The tied column in figure is a member of a braced frame. The factored moments shown produce bending about the weak axis is 90k-ft and factored axial load is 250 kip. Moments about the strong axis are zero. The effective-length factor  $k$  equals 0.9 with regard to bending about the  $y$ - $y$  axis and 0.85 with respect to bending about the  $x$ - $x$  axis. Determine the longitudinal reinforcement required to support the factored loads. Consider  $f'_c = 3$  ksi and  $f_y = 60$  ksi.  $\beta_d = 0.6$ . Column section is 12"x18" and clear height of column is 18 ft.

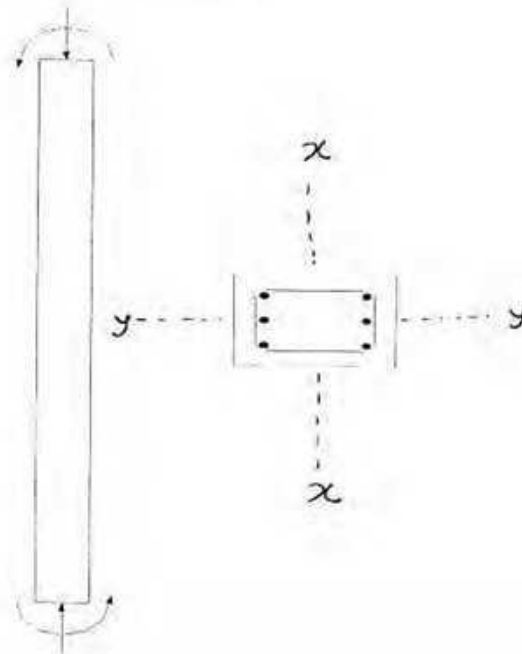

8. A transfer girder is to carry two columns, each with factored load of 2400 kips at the third points of its 42 ft span. A beam width of 2.5 ft and total depth of 18 ft are tentatively selected according to geometric requirements. Design the beam for the given loads. Ignore self-weight.

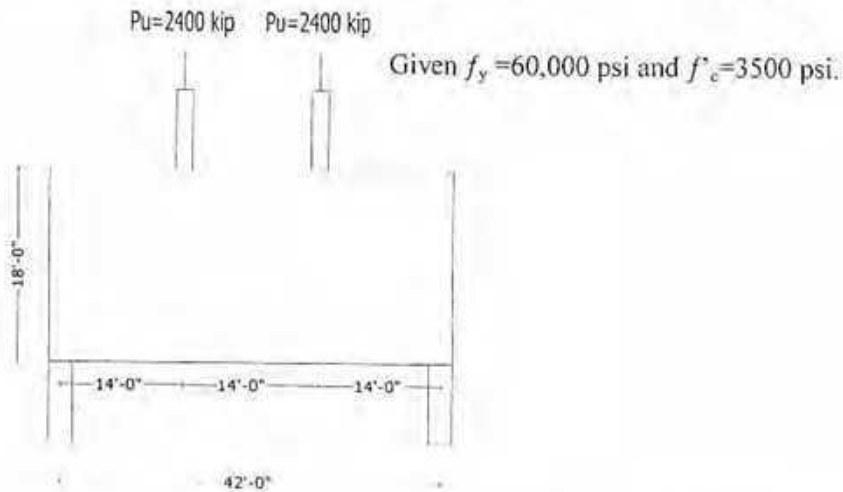

9) The 30 ft clear span beam shown below carries a monolithic slab cantilevering 8 ft past the beam center line, as shown in the section. The resulting L beam supports a live load of 600 lb/ft along the beam centerline plus 40 psf uniformly distributed over the upper slab surface. The width of the beam is 15" effective depth to the flexural steel centroid is 26.5 in., and the distance from the beam surfaces to the centroid of stirrup steel is  $1\frac{1}{4}$  in. material strengths are  $f'_c = 3500 \text{ psi}$  and  $f_y = 60,000 \text{ psi}$ . Design the torsional reinforcement of the beam.

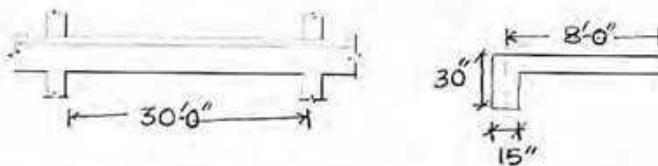

10) A circular ring beam supporting a steel hopper has mean diameter of 36 ft supported by six symmetrically placed vertical column. The beam carries a total factored udl 10 kip/ft. The beam section is 24"x48". Design the beam by using  $f'_c = 3500 \text{ psi}$  and  $f_y = 60,000 \text{ psi}$  material.