

THE UNIVERSITY OF ASIA PÁCIFIC
Department of Civil Engineering
Mid-Term Examination; Fall-2011

Course Title: Principles of Accounting; Course Code: ACN – 301; Credit -2

Time: 1 hour

Full Marks - 20

(There are five questions. Answer any 4 (Four) questions. All question carry equal marks)

1. Define Accounting. Explain the Accounting Process.
2. What is Accounting Equation? Explain the terms used in Accounting Equation.
3. What do you mean by Double Entry System? State the rules of Debit and Credit.
4. Journalize the following transactions in the books of Z Ltd., a consulting firm for the month of June, 2011.

June 1 Mr. 'Z' invested Tk. 2,50,000 cash in the business.
" 2 Purchased furniture Tk. 60,000 and a computer with necessary accessories Tk. 40,000.
" 3 Purchased supplies on credit Tk. 20,000 from X Ltd.
" 5 Received cash for services rendered Tk. 60,000.
" 8 Consulting services rendered to Y Ltd. Tk. 50,000. The amount is not yet received.
" 10 Paid 50% of balance due to X Ltd.
" 15 Determined that 60% of the supplies had been used.
" 20 Received Tk. 1,00,000 as advance for consulting service.
" 25 Paid employees salaries Tk. 25,000, utilities Tk. 8,000 and repairs Tk. 9,000.
" 30 Consulting fees earned Tk. 80,000 against advance received on 20th June

5. Prepare A Trial Balance of Y Ltd. as on 30.06.2011 from the following ledger balances:

Cash Tk. 28,600. Accounts Receivable Tk. 24,150, Prepaid Insurance Tk. 1,450, Bills Payable Tk. 18,950, Stock of Supplies Tk. 20,800, Land Tk. 30,000, Building Tk. 55,000, X's Capital Tk. 1,10,090, Sales Tk. 2,75,750, Purchase Tk. 1,62,190, Sales Return Tk. 1,000, Return Outward Tk. 700, Sales discount Tk. 1,850, Purchase discount Tk. 1,300, Carraige Inward Tk. 3,650, Salaries Tk. 69,000, Advertising Tk. 6,000, Delivery expenses Tk. 2,300, Interest revenue Tk. 200, Interest expenses Tk. 1,000

University of Asia Pacific
Department of Civil Engineering
Mid Semester Examination Fall 2011

Course # CE 101
 Full Marks: 30

Course Title: Engineering Mechanics I
 Time: 1 hr

There are FOUR questions. Answer any **THREE**.
 Each question carries equal number.

1. In the figure below, the resultant of the forces F_1 , F_2 , F_3 and F_4 is 1500 lbs, which acts vertically upwards. Calculate the magnitudes of F_3 and θ .

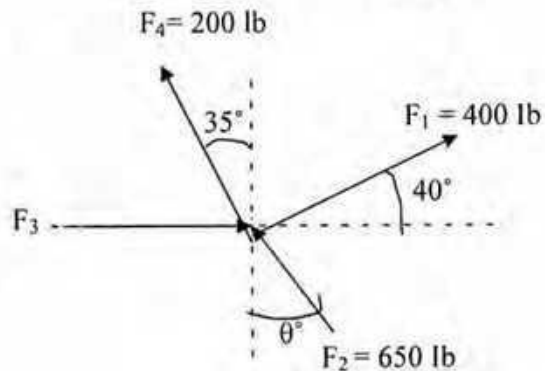

2. (a) Calculate the magnitude of the resultant of the load. Show the direction and location (with respect to a point, for example point A) of the resultant in each case (i-iv).

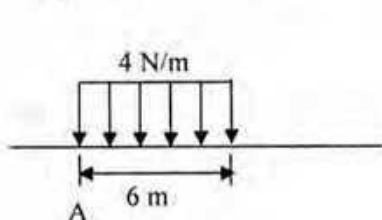

(i)

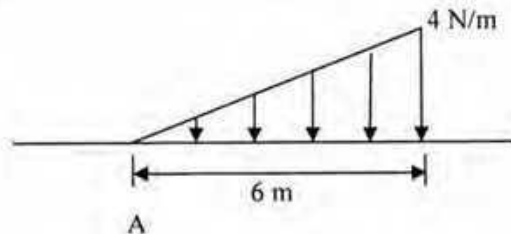

(ii)

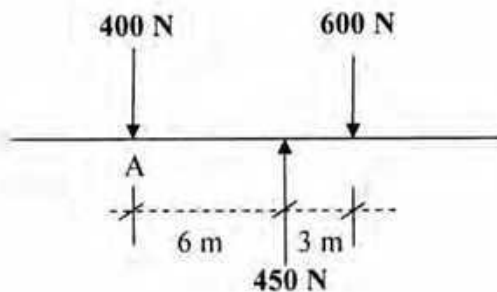

(iii)

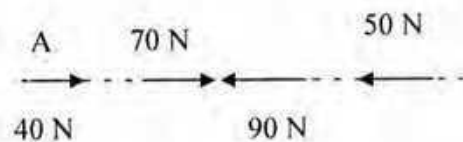

(iv)

(b) Calculate the reactions at the support A.

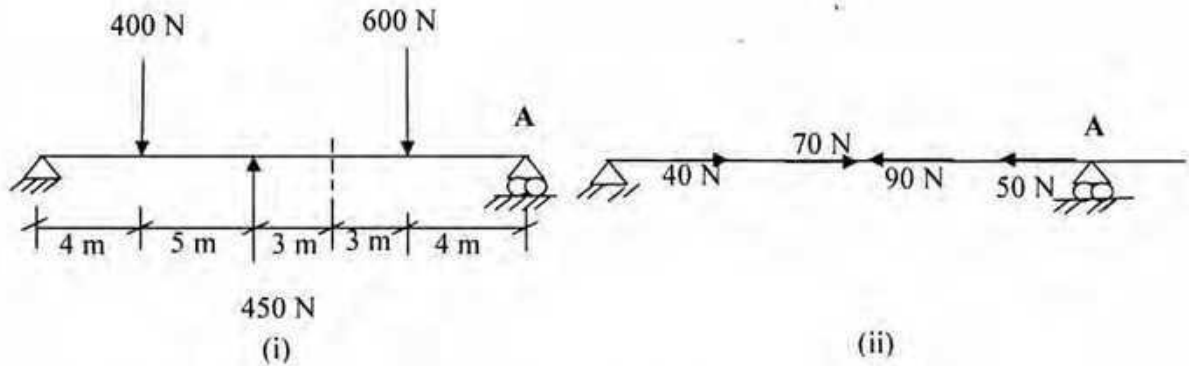

3. Calculate the reactions at the supports at A and C.

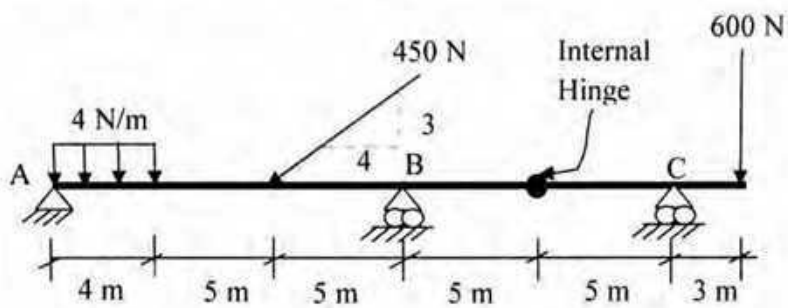

4. Calculate the reactions at the support A and tension in the cable. Identify two force member.

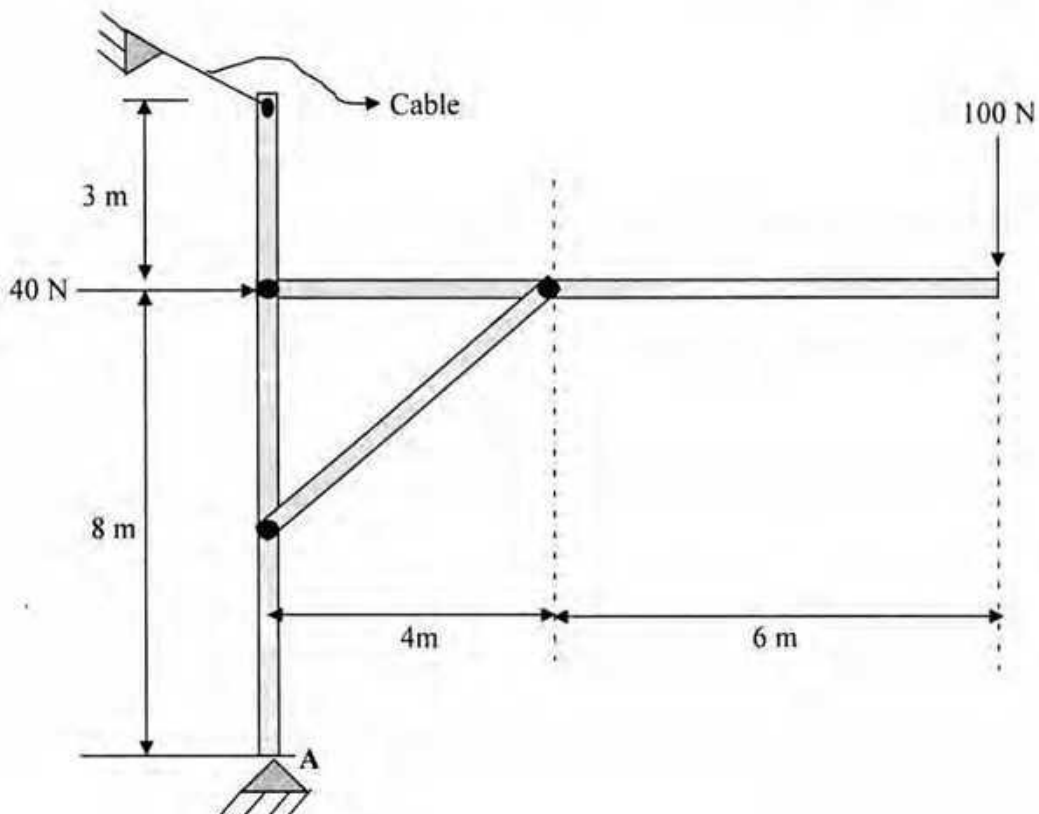

University of Asia Pacific
Department of Civil Engineering
Mid Semester Examination, Fall 2011
Program: B. Sc. Engineering (Civil)

Course Title: Engineering Mechanics II
 Time: 1 hour

Credit Hours: 3.0

Course Code: CE 103
 Full Marks: 40 (= 4 × 10)

[Answer any 4 (Four) of the following 5 (Five) questions]

1. If the body A is impending to move downward what is the weight of A, when the weight of body B is ω ? Given, $f_A = (\tan \theta^\circ)/3$, $f_B = \tan \phi^\circ$, $f_C = 0$ and $f_D = 1/3$.

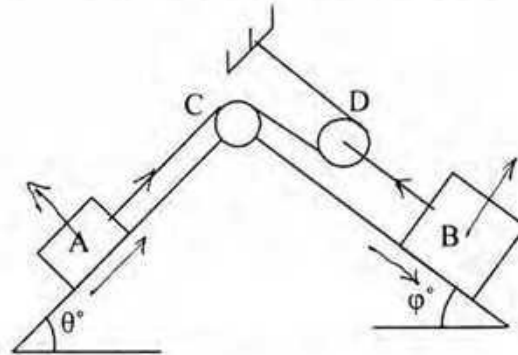

2. Determine the minimum coefficient of static friction between the 100 lb spool and the wall so that the spool does not slip.

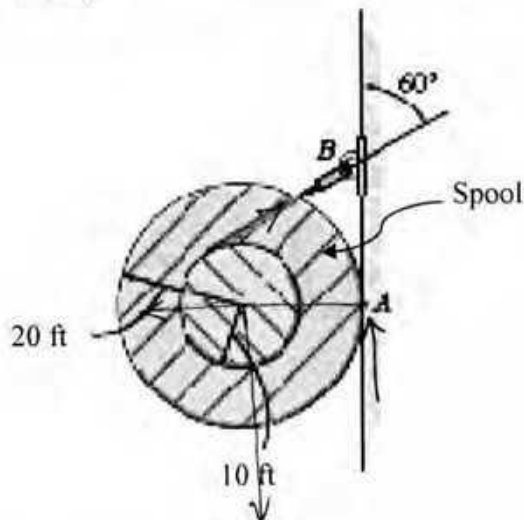

3. The rectilinear motion of a particle is expressed in terms of the following equation:

$$a = 5t^2 + 3t - 15$$
 The particle is moving with an initial velocity of 10 fps in the same sense as the initial acceleration. Derive (a) velocity versus time function, and (b) displacement versus time function. (c) Calculate the displacement in the 15th sec. Here, "a" is in ft/s² and "t" is in sec.

4. Determine the mass moment of inertia of the overhung crank about the x' axis. The material is steel having a unit weight of 500 lb/ft^3 .

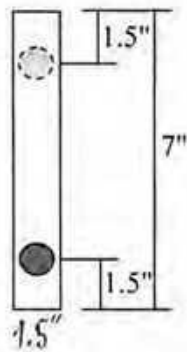

Right View

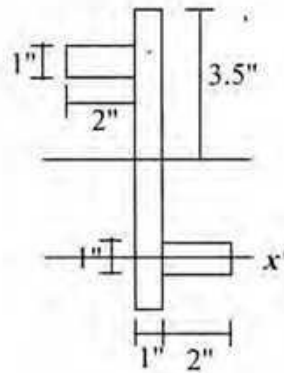

Front View

5. If the large ring, small ring and each of the spokes weigh 100 lb, 15 lb, and 20 lb, respectively, determine the mass moment of inertia of the wheel about an axis perpendicular to the page and passing through point A .

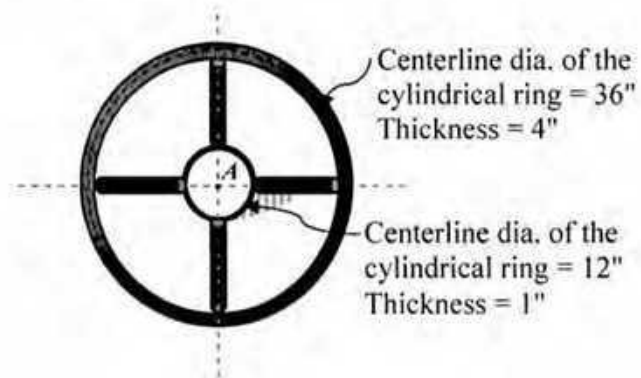

University of Asia Pacific
Department of Civil Engineering
Mid Semester Examination Fall 2011 (Set B)

Course #: CE 103
 Full Marks: 40 (= 4 × 10)

Course Title: Engineering Mechanics II
 Time: 1 hour

- The figure below shows a frame ABC consisting of two 10-ft long uniform members AB and BC, each weighing 50 lb. Calculate the
 - Angle (θ) the members should be set at to keep them in impending motion
 - The floor reactions at A and joint reactions at B when the members are in impending motion
 [Given: Friction factor at floor $f_s = 0.30$].

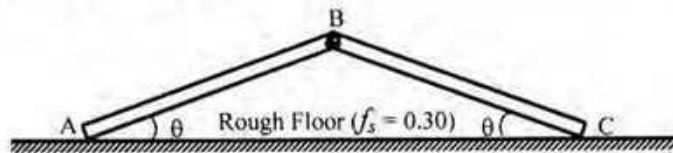

- Calculate the mass moments of inertia (I_x, I_y) about the x - and y -axis of the composite hammer (made of wood and steel) shown below [Given: Unit weight of wood = 50 lb/ft³, unit weight of steel = 490 lb/ft³].

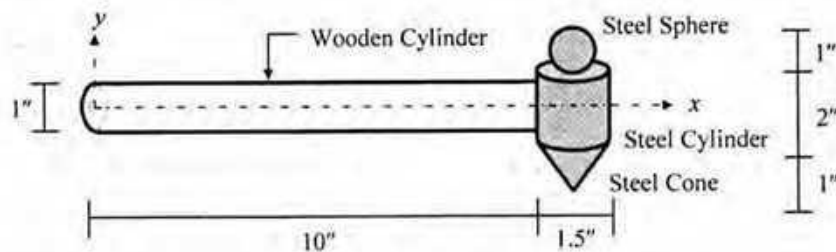

- The motion of a particle is defined by the equation $y = ax + bx^2$, where a and b are constants. Calculate the values of a and b , if it starts at point $(0, 0)$ with a velocity (v_x) of 25 m/sec and travels at a constant horizontal velocity (v_x) of 15 m/sec and constant vertical acceleration (a_y) of -9.81 m/sec².
- The figure below shows a box A (weighing $W_A = 100$ lb) being pulled by box C (weighing $W_C = 10$ lb) over pulley B along a smooth plane. Calculate the magnitude and direction of acceleration of the system, if the angle θ is equal to (i) 0° , (ii) 30° [Given: $f_s = 0.30, f_k = 0.20$ for the pulley B].

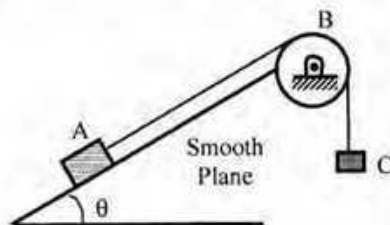

{ For pulley B
 $f_s = 0.30, f_k = 0.20$

The University of Asia Pacific
Department of Civil Engineering
Mid-Term Examination Fall2011
Program: B.Sc. Engineering (Civil)

Course Title: Surveying
Time : 1 hr

Course Code: CE 105

Credit: 4.00
Full Marks: 60

There are **Four** questions in this section. Answer any **Three**

1. (a) Explain with neat diagrams the construction and working principle of an optical square. (10)
 (b) Write short notes on i) Check line ii) Engineer's Chain (5)
 (c) The magnetic bearing of a line AB is S 58° 30' E. calculate the true bearing if the declination is 8° 35' E. (5)

2. (a) What are the difference between chain surveying and traverse surveying? (5)
 (b) For the following traverse, compute the length CD so that A,D and E may be in one straight line (10)

Line	Length (m)	FB
AB	110	83° 20'
BC	170	30° 35'
CD	-	340° 40'
DE	220	15° 36'

- (c) How can you erect a perpendicular to a chain line from a point on it by chain or tape? (5)
3. (a) What is closing error in a traverse surveying? How can you balancing the traverse? (1+5)
 (b) Below are the bearings observed in traversing with a compass in a place, where local attraction was suspected: (14)

Line	Fore Bearing	Back bearing
AB	80° 30'	260° 30'
BC	351° 15'	172° 00'
CD	32° 15'	208° 00'
DE	106° 15'	287° 45'
EF	99° 00'	280° 00'
FG	209° 30'	29° 30'

At what stations do you suspect local attraction? Find the corrected bearings of the lines.

4. (a) What are the difference between Height of Instrument Method and Rise and Fall Method? (4)
 (b) What is contour? (1)
 (b) The following notes refer to reciprocal levels taken with one level: (4+4+7)

Instrument Near	Staff reading on		Remarks
	P	Q	
P	1.82	2.76	Distance PQ = 1000 m
Q	0.95	1.61	R.L of P = 125.50 m

Find (i) True R.L of Q, (ii) The combined correction for curvature and refraction.
 (c) The angular error in the collimation adjustment of the instrument.

The University of Asia Pacific
Department of Civil Engineering
Mid-Term Examination Fall' 2011

Course No: CE 105
Full Marks: 60

Course Title: Surveying
Time: 1 hour

Answer ALL:

1. Compute the area of a pentagon ABCDE using coordinate method and determine the relative precision of the map. Given, the coordinate of A is 10000, 5000; Bearing of AW line is S 54-17-18 W, Angle to right for WAE is 151-52-24; The interior angles A, B, C, D, E are respectively 100-45-37, 231-23-43, 17-12-59, 89-03-28, 101-34-24; Lengths AB, BC, CD, DE, EA are respectively 647.25, 203.03, 720.35, 610.24, 285.13 ft. (50)
2. What is precise leveling? What is reciprocal leveling? You are to measure the height of an establishment (nuclear power plant). What equipments should you carry with you? (10)

University of Asia Pacific
Department of Civil Engineering
Mid Term Examination Fall 2011

(SECTION – A)

Course Title: Introduction to Civil and Environmental Engineering
Course Code: CE 107

Full Marks: 40

Time: 1 hour

1. Describe the following (*any four*): (2x4=8)
 - a. Age Structure
 - b. Important impacts due food surplus during agricultural societies
 - c. Maximum sustainable yield
 - d. Environmental Engineering
 - e. Basic environmental issues
 - f. Water Resources in Bangladesh

2. It took the Dhaka city about 42 years to increase in population from 40 lakh to 120 crore. If we assume exponential growth at a constant rate over that period of time, what would that growth rate be? (5)

3. Define water pollution? Write four types of surface and ground water pollution and their sources. (2+4=6)

4. Describe different uses and issues of water. (8)

5. Derive the equation of doubling time as a function of growth rate (3)

6. Suppose the human population follows a logistic curve until it stabilizes at 16.0 billion. In 2001 the world's population was 6.0 billion and its growth rate was 1.6 percent. When would the population reach (a) 8 billion? (b) 12 billion? (8)

7. Write about the career of civil engineers in Bangladesh (2)

University of Asia Pacific
Department of Civil Engineering
Mid Semester Examination Fall 2011
Program: B.Sc. Engineering (Civil)

Course No.: CEE 107 (Sec B) Course Title: Introduction to Civil & Environmental Engineering
Full Marks: 40 Time: 1 hour

Answer **One**. All questions carry equal marks.

1. (a) What is the role of an Architect and Civil engineer? (2)
- (b) Define : (a) Plinth level (b) formation level (c) foundation (e) basement (4)
- (c) Elaborate different requirements as per building byelaws of following items in a building. (6)
- i. Plinth and Formation Level ii. Habitable Rooms
- iii. Ramps
- (d) Mr. Aziz submits a building plan to the RAJUK authority for approval. Do you see any irregularities in the plan with respect to the followings, (8)
- a. Distance of the building from the adjacent road
b. Building height c. Car parking area
d. Minimum side clearance e. Minimum back clearance

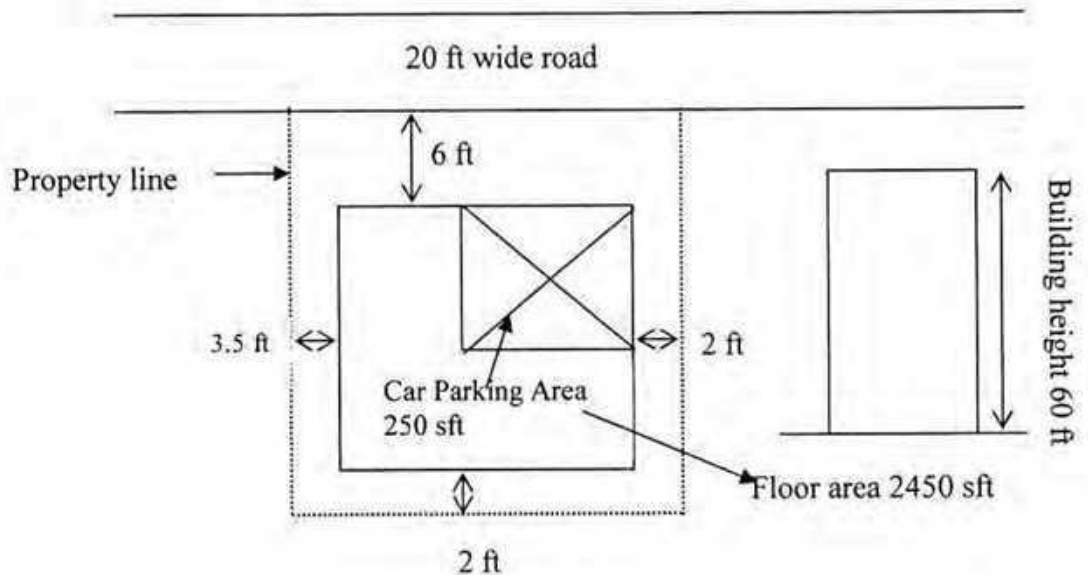

SECTION B

Answer TWO from the following. Each question carry 10 marks.

1. (a) Mention various steps of planning and scheduling a high way project. (4)
- (b) Define: (i) FAR; (ii) Set Back (3)
- (c) Write a short note on the occupancy type of a building classified by RAJUK. (3)

2. (a) Briefly discuss the problems in the development of transportation system in Bangladesh. (5)
- (b) Briefly discuss the difficulties faced while using automated construction equipments. (5)

3. (a) For a 60 m wide and 80 m long plot and 20 m wide adjacent road, calculate the followings: (6)
- (i) What will be the minimum front set back as per RAJUK rules?
- (ii) What is the Floor Area ratio (FAR) of the building for 50% ground coverage?
- (b) What is meant by the term 'contract'? Mention different types of contract. (4)

The University of Asia Pacific
Department of Civil Engineering
Mid Semester Examination Fall 2011
Program: B. Sc. Engineering (Civil)

Course Title : Engineering Materials
 Time: One Hour

Course Code: CE 201
 Full Marks: 40

Answer all Questions. The figures in the right margin indicate the marks of the questions.

1. Shore pile construction work of UAP City Campus is running at Firm Gate, Dhaka. From the site, some coarse aggregates were collected for sieve analysis at Concrete Laboratory of UAP. Test results are summarized below: 15

ASTM Sieve	Material Retained (g)
3 inch	0
1.5 inch	0
¾ inch	709
3/8 inch	2209
#4	1678
#8	373
#12	0
#16	25
#30	0
#40	0
#50	0
#100	0
#200	4
Pan	2

- (i) Calculate the FM of the sample,
 (ii) Draw the grading curve of the sample,
 (iii) What measures are necessary to improve the grading of the sample?

Sieve openings: #12 - 1.7 mm, #40 - 0.425 mm, and #200 - 0.075 mm.

2. (a) What changes are necessary in the composition of cement to make cement with the following properties: 3
- (i) High early strength,
 (ii) Low heat cement, and
 (iii) Sulfate resisting cement.
- (b) Compare setting and hardening of cement. 1
- (c) Explain the mechanism of bulking of sand. 2

- (d) Draw typical stress strain curves for concrete, steel, glass, rubber, and copper. 2.5
- (e) Discuss the reasons for formation of efflorescence on brick surface. 1.5
3. Refer to the following data associated with a sand sample: 5
- Volume of the OD sample = 0.1 m^3
Weight of the OD sample = 140 kg
Bulk specific gravity (OD Basis) of the sand = 2.6
Absorption Capacity = 1%
- Calculate the following:
- (i) Amount of void in the sample and
 - (ii) SSD unit weight of the sample.
4. Mixture proportion of mortar is necessary for plastering work on a brick wall of a building project. The following data are provided: 10
- Sand to cement ratio (weight ratio) = 3.0,
W/C=0.5,
Specific gravity of cement = 3.1,
Specific gravity of sand = 2.6,
Air content = 2% ,
- (i) Calculate the unit contents of sand, cement, and water,
 - (ii) Calculate the unit weight of mortar,
 - (iii) What adjustment in sand volume is necessary, if bulking of sand is 20%?

The University of Asia Pacific
Department of Civil Engineering
Midterm Examination Fall 2011

Course # : CE-203

Course Title: Engineering Geology & Geomorphology

Full Marks: 45 (15 X 3 = 45)

Time: 1 hour

Answer any **three (3)** questions of your choice out of the following **four (4)**

- 1a) Mention the principal zones of the earth from geologic point of view. Describe any one. 5
- 1b) Draw a schematic diagram of the rock cycle and provide one example of each type of rock. 5
- 1c) Classify (mention names only) geomorphic processes based on origin. Also classify (mention names only) physical and chemical weathering processes. 5
- 2a) Define precipitation, infiltration and percolation. Draw a schematic diagram of hydrologic cycle and show their relative locations of occurrences in conjunction with runoff. 7
- 2b) Derive a relationship between FF and CC. 2
- 2c) In the following basin, for what value of x , the flow rate (Q) or runoff will be the maximum? 6

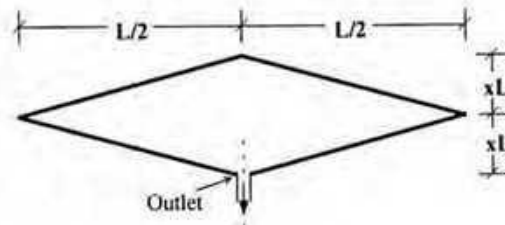

- 3a) Mention the factors affecting runoff. 5
- 3b) Write down the assumptions used in rational formula. 2
- 3c) For the drainage area as shown below, calculate peak runoff in ft^3/s . Use $C_2 = 0.8$, $C_3 = 0.5$ and $C_4 = 0.7$ and $I = 0.2 \text{ cm/min}$. 8

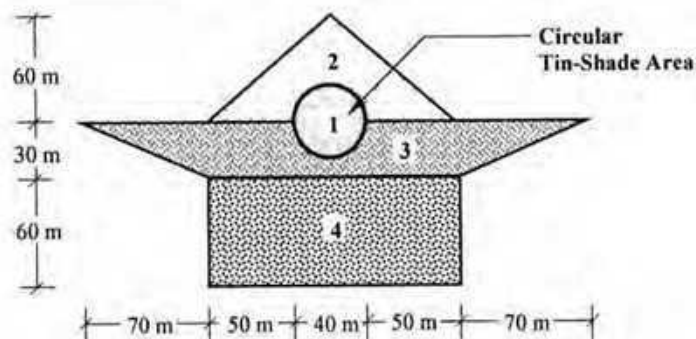

- 4a) Classify (mention names only) folds based on their origin. Draw a neat sketch of typical fold geometry. 6
- 4b) Define fault. Classify fault (mention names only) and sketch faults according to net slip. Draw a neat sketch of a horst. 9

Course No: CE 205
Course Title: Numerical Analysis & Computer Programming.

Time: 1 hour
Full Marks: 20

[Answer all the four questions]

1. Solve the following system of equations using *Gauss Jordan* method: (6)

$$\begin{aligned}5a - b - 2c &= 142 \\ a - 3b - 4c + 30 &= 0 \\ 2a - b - 3c &= 5\end{aligned}$$

or

Solve the following system of equation by *Gauss Elimination* method,

$$\begin{aligned}a + b + c &= 6 \\ 3a + 3b + 4c &= 20 \\ 2a + b + 3c &= 13\end{aligned}$$

2. Using *Newton Raphson* method, find the real root of the following equation: (4)
 $f(x) = x \sin(x) + \cos(x)$ desired accuracy = 0.0001

or

Using the *Iteration* method, find the root of the equation

$$\ln x = \frac{\sin x}{x}$$

up to four decimal places, $\epsilon = 0.0001$

3. Solve the following system of equations using *Gauss-Seidel* method: (6)

$$\begin{aligned}u + v + 54w &= 110 \\ 27u + 6v &= 85 + w \\ 6u + 15v + 2w &= 72\end{aligned}$$

or

Solve the following system of equations using *Crout's* method:

$$\begin{aligned}u + v + w &= 1 \\ 3u + v &= 5 - 3w \\ 10 + 2v + 5w &= u\end{aligned}$$

4. Using *Reguli-Falsi* method find the solution of $f(x) = 3x - \sqrt{1 + \sin x}$, (4)
desired accuracy = 0.0001

or

Using *Newton's Iterative* formula, find cube root of 25.

The University of Asia Pacific
Department of Civil Engineering
Mid Semester Examination Fall 2011

Course No.: CE 211
 Full Marks: 30 (= 3 × 10)

Course Title: Mechanics of Solids I
 Time: 1 hour

There are **four** questions in this paper. Answer any **three**.

1. For the beam *abcdefg* loaded as shown in the figure below
- Derive the equations for shear force and bending moment using Singularity Functions,
 - Also calculate shear force at left of point *d* and bending moment at the right of point *b*.

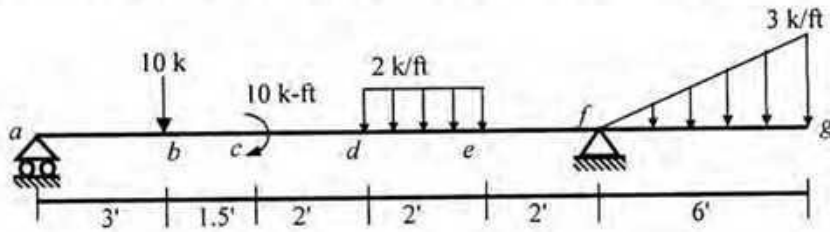

2. Draw the axial force, shear force and bending moment diagram of the following beam.

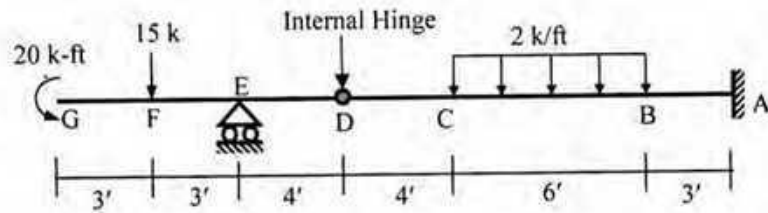

3. For the member X of the truss shown below, calculate the lengths of $\frac{3}{4}$ inch weld required on three sides of the member.
 [Given: Allowable shear stress = 16 ksi].

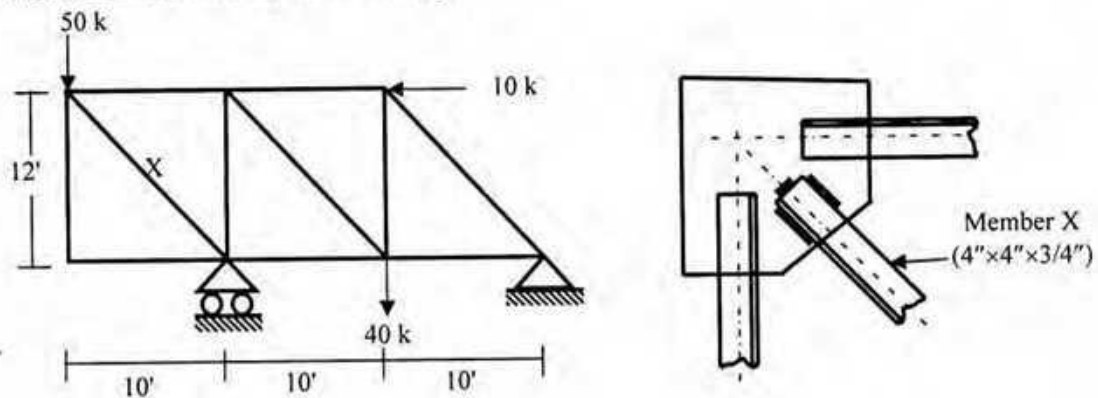

4. In the truss ABCD shown below, use factor of safety = 1.5 to calculate the required
(i) Bolt diameter (d), (ii) Thickness (t) of member BD, (iii) Width (b) of member BD
[Given: Shear strength = 150 MPa, bearing strength = 250 MPa, axial strength = 200 MPa].

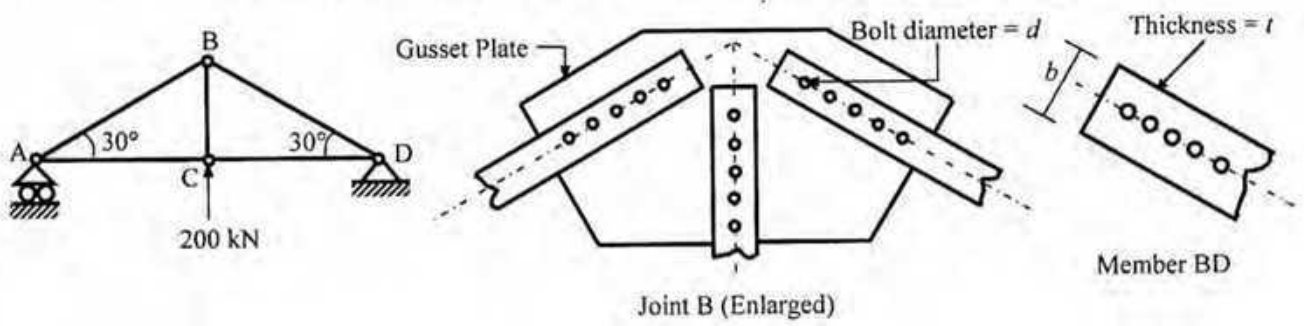

University of Asia Pacific
Department of Civil Engineering
Mid Semester Examination Fall 2014 (Set B)

Course #: CE 211
 Full Marks: 40 (= 4 × 10)

Course Title: Mechanics of Solids I
 Time: 1 hour

1. Draw the AFD, SFD and BMD of the beam *abcdefg* loaded as shown in Fig. 1.

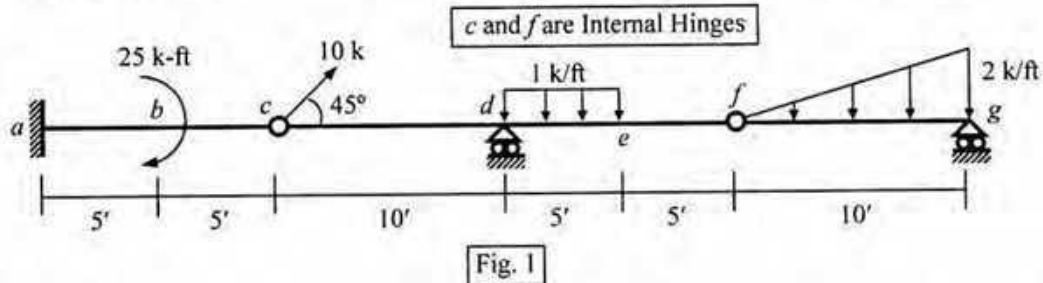

2. For the beam *abcdefg* loaded as shown in Fig. 1, use the Singularity Functions to derive the equations for shear force and bending moment, and calculate the
 (i) Shear Force just at *f*, (ii) Bending Moment just at the left and right of *b*.
3. Calculate the allowable force *F* at the bolted joints A and B shown in Fig. 2, considering only the shearing and bearing stresses in the 1"-dia bolts and 0.5"-thick plates.

To resist the force *F*, also calculate the required
 (i) plate widths b_A and b_B [at the joints A and B],
 (ii) lengths (L_w) of the 0.25"-thick welds [at the joint C]

[Given: Allowable stress in shearing = 16 ksi (both bolt and weld), bearing = 20 ksi, tearing = 18 ksi].

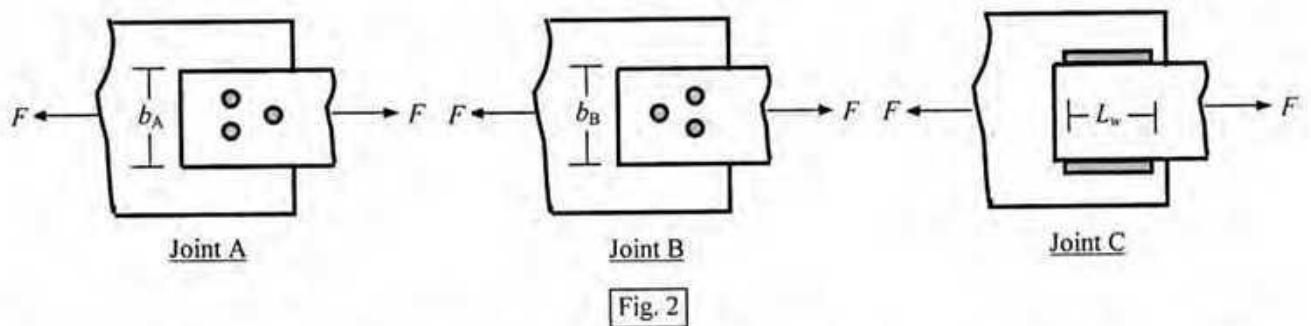

4. Determine the normal stresses (σ_{xx} , σ_{yy} , σ_{zz}) required to deform a (1 m × 1 m × 1 m) cube while keeping its volume constant (with $\epsilon_{xx} = -0.02$, $\epsilon_{yy} = 0.0$), if it is made of linearly elastic material

[Given: Modulus of Elasticity $E = 21000$ MPa, Poisson's ratio $\nu = 0.30$].

Sec B

University of Asia Pacific
Department of Civil Engineering
Mid Semester Examination Fall 2011

Course Code : CE 213

Full Marks : 30

Course Title : Mechanics of Solid II

Time : 1 hour

(There are Four questions. Answer any Three)

1. Use the Mohr's Circle or stress transformation to calculate the normal stress and shear stress on the plane a-a' and plane b-b' shown in the element below. Line a-a' and b-b' are perpendicular to each other. Calculate the magnitude and direction of maximum and minimum normal stress

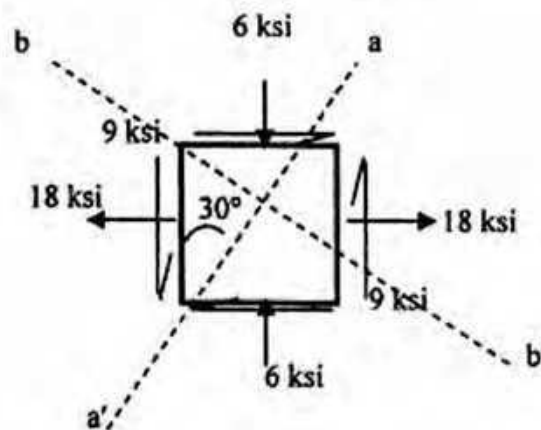

2. A simple beam with depth to width ratio of 2:1 has a span of 3.6 m and carries a UDL of 15 kN/m as shown below. The loading plane is inclined 30° clockwise with vertical. Determine the required dimension (b & h) so that the maximum stress due to bending does not exceed 12 MPa. Neglect self-weight of beam. Also locate the neutral axis.

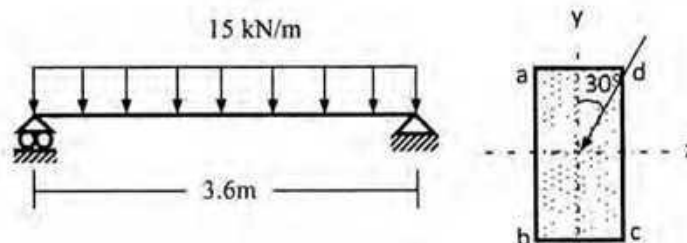

3. Calculate the torsional shear stress at A and the torsional rotation at B for the circular rod (of non-uniform diameter) shown below (Neglect stress concentration) [Given: $G = 12000 \text{ ksi}$].

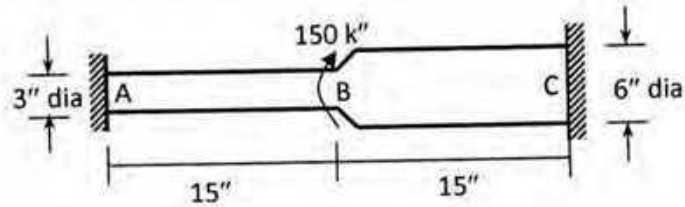

4. Calculate the maximum shear stress in the composite section shown in following figure when subjected to a torque of 15 k-ft .

Also calculate the diameter (D) of the hollow circular section that has the same maximum stress when subjected to the same torque. [$G = 12000 \text{ ksi}$]

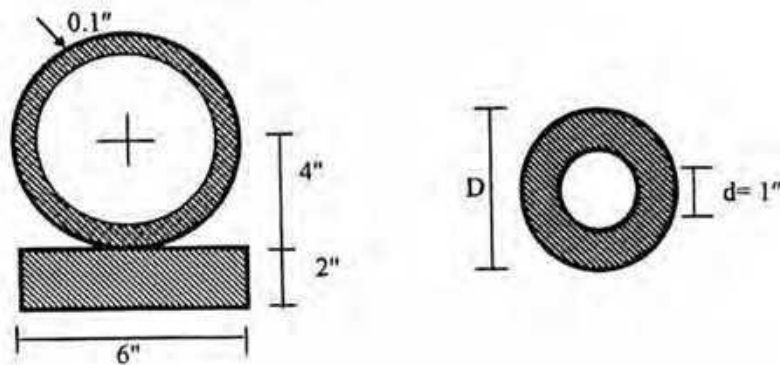

University of Asia Pacific
Department of Civil Engineering
Mid Semester Examination Fall 2011

Course Code : CE 213
 Full Marks : 30

Course Title : Mechanics of Solid II
 Time : 1 hour

(There are **Four** questions. Answer any **Three**)

1. a) What do you understand by "Kern of a Footing Area"? Derive required expression to locate the kern zone of a rectangular footing area.
 b) Write down the statement and condition of Rankin's theory and St. Venant's theory of Yield criteria.

2. Calculate the maximum shear stress in the composite section shown in following figure when subjected to a torque of 20 k-ft.
 Also calculate the diameter (D) of the hollow circular section that has the same maximum stress when subjected to the same torque. [G=12000 ksi]

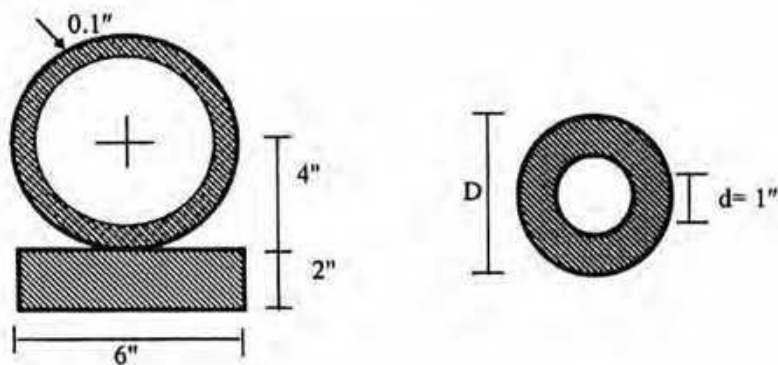

b/t	1.0	1.5	2.0	3.0	6.0	10.0	α
α	0.208	0.231	0.246	0.267	0.299	0.312	0.333
β	0.141	0.196	0.229	0.263	0.299	0.312	0.333

P.T.O

3. Use the Mohr's Circle or stress transformation to calculate the normal stress and shear stress on the plane a-a' and plane b-b' shown in the element below. Line a-a' and b-b' are perpendicular to each other. Calculate the magnitude and direction of maximum and minimum normal stress.

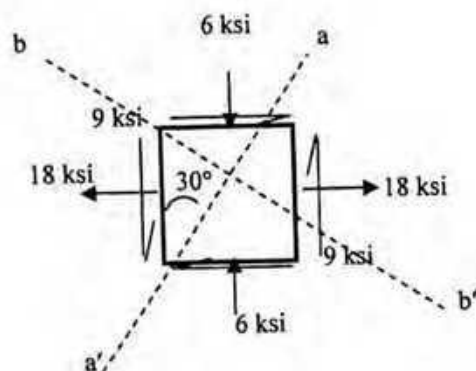

4. A simple beam with depth to width ratio of 2:1 has a span of 3.6 m and carry UDL of 21 kN/m as shown in Fig 3. The loading plane is inclined 30° clockwise with vertical. Determine the required dimension (b & h) so that the maximum stress due to bending does not exceed 12 MPa. Neglect self-weight of beam. Also locate the neutral axis.

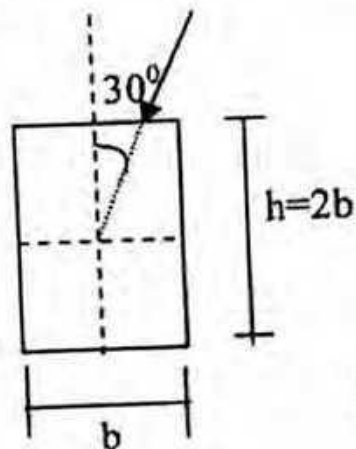
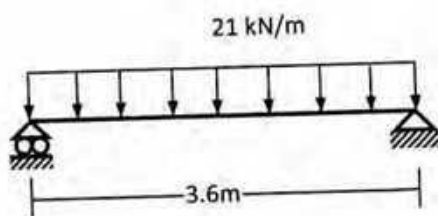

Fig.3

University of Asia Pacific
Department of Civil Engineering
Mid Term Examination Fall 2011

Course Title: Fluid Mechanics
 Time: 1.0 hour

Course No: CE 221
 Full Marks: 60

The symbols have their usual meanings.
The figures the right margin indicate full marks.

1. Differentiate between the following terms (any three): (3×4 = 12)
 - i. Newtonian and non-Newtonian fluid
 - ii. Steady and unsteady flow
 - iii. Piezometer and manometer
 - iv. Streamline and pathline
2. Derive the expression for Newton's law of viscosity. (10)
3. A liquid has an absolute viscosity of 0.23 P. It weighs 8.40 kN/m^3 . Determine the kinematic viscosity of the liquid in the units of Stoke. (8)
4. Calculate the capillary rise/drop in a glass tube of 2.50 mm diameter when immersed in mercury at 20°C . The values of σ and ρ of mercury at 20°C are 0.51 N/m and $13,550 \text{ kg/m}^3$, respectively. Assume a reasonable value of the contact angle. (10)
5. Compute the pressure difference between points A and B of Figure 1. (10)

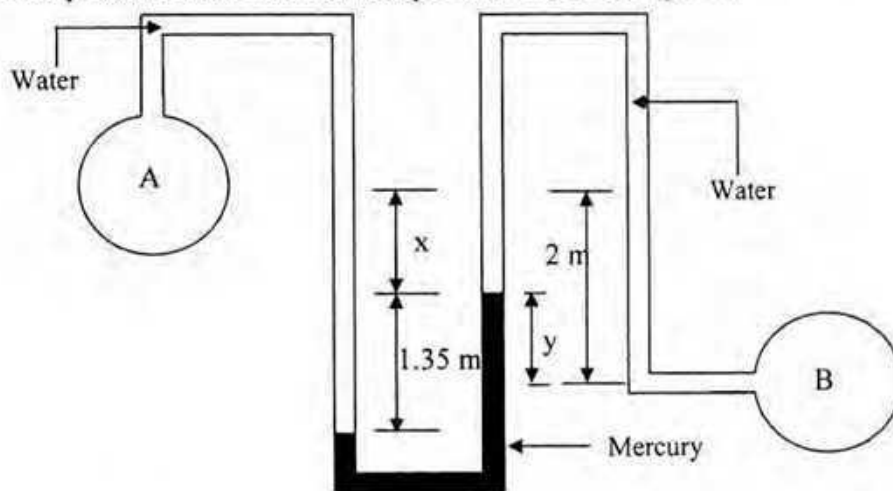

Figure 1

6. Find the horizontal and vertical forces acting on the gate AB as shown in Figure 2. The gate is a quadrant of a circle of radius 3 m. The length of the gate perpendicular the plane of the paper is 2 m. At what angle will the resultant force be acting to the horizontal? (10)

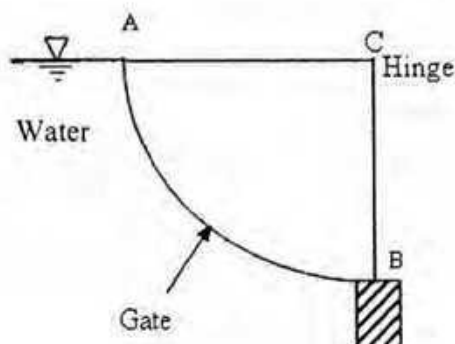

Figure 2

University of Asia Pacific
Department of Civil Engineering
Mid Semester Examination Fall 2011
 (Section A)

Course Code : CE 313
 Course Title : Structural Engineering II

Full Marks : 30
 Time : 1 hour

(There are **Four** questions. Answer any **Three**)

1. For the frame loaded as shown below, draw
- | | | |
|------|-----------------------------------|---|
| i. | Beam BMD | 2 |
| ii. | Column BMD(column CD & EF only) | 4 |
| iii. | Column AFD (column CD & EF only) | 4 |

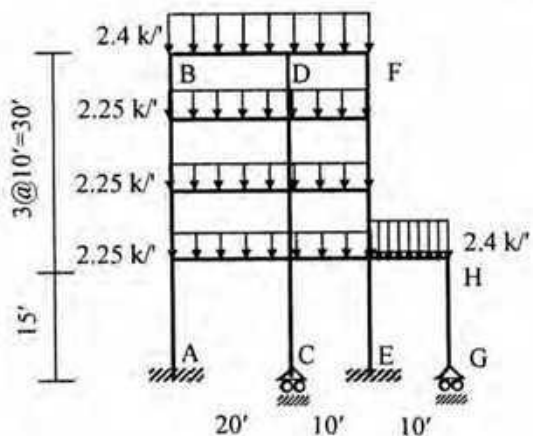

2. For the building frame shown below draw the Bending Moment Diagrams for the column ABC and girder DBE using **Portal Method**. 10

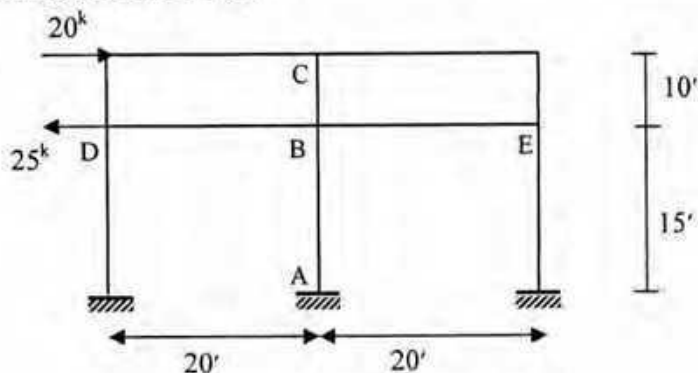

3. For the building frame shown below draw the Bending Moment Diagrams for the column ABC and girder DBE using **Cantilever Method**. 10

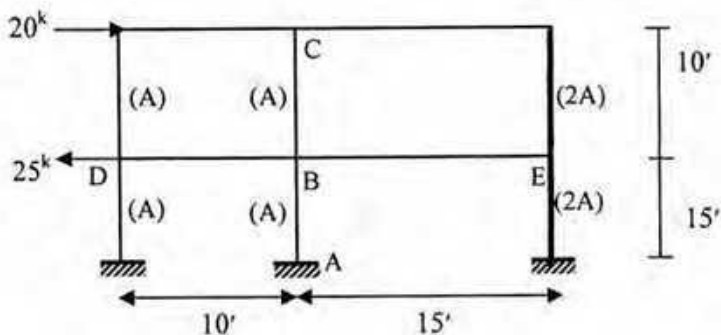

4. Determine the vertical deflection at point E of the beam shown below using **Virtual Work Method**. (Consider E and I as constant) 10

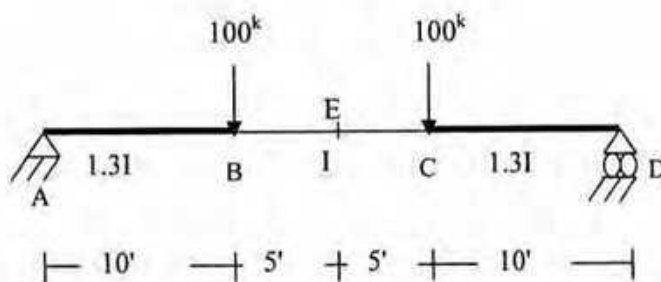

INTEGRATION RESULT

$$I = \int m_i m_j dx \text{ Values}$$

$m_i \backslash m_j$					
	Aal	$Aal/2$	$Aal/2$	$(A+B)al/2$	$\frac{l^2}{6} \frac{A+4B+C}{(A+4B+C)}$
	$Aal/2$	$Aal/3$	$Aal/6$	$(A+2B)al/6$	$(2B+C)al/6$
	$Aal/2$	$Aal/6$	$Aal/3$	$(2A+B)al/6$	$(A+2B)al/6$
	$A(a+b)l/2$	$A(a+2b)l/6$	$A(2a+b)l/6$	$(A(2a+b)+B(2l+a))l/6$	$(Aa+Cb+2B(a+b))l/6$

$$a \geq b \text{ or } a \leq b$$

[a, b can be -ve or +ve]

University of Asia Pacific
Department of Civil Engineering
Mid Semester Examination Fall 2011
 (Section A)

Course Code : CE 313

Course Title : Structural Engineering II

Full Marks : 30

Time : 1 hour

(There are Four questions. Answer any Three)

1. For the frame loaded as shown below, draw
- | | |
|--|---|
| i. Beam BMD | 2 |
| ii. Column BMD (column CD & EF only) | 4 |
| iii. Column AFD (column CD & EF only) | 4 |

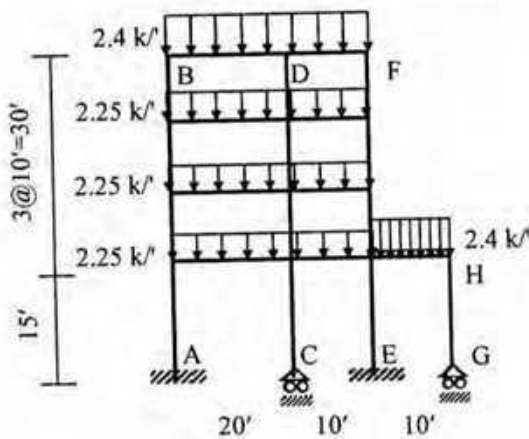

2. For the building frame shown below draw the Bending Moment Diagrams for the column ABC and girder DBE using **Portal Method**.

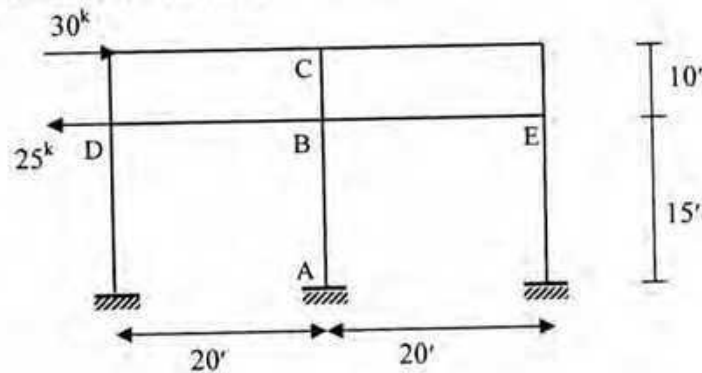

3. For the building frame shown below draw the Bending Moment Diagrams for the column ABC and girder DBE using **Cantilever Method**. 10

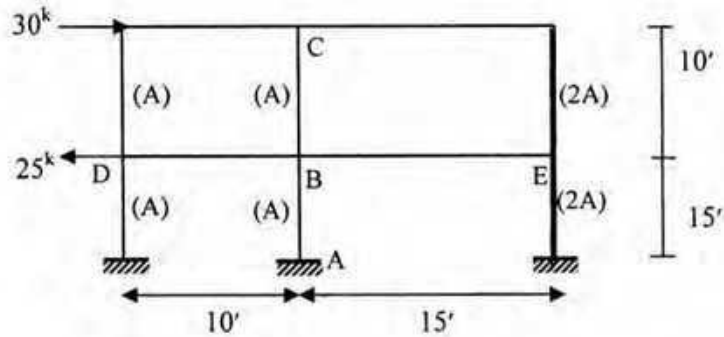

4. Determine the vertical deflection at point E of the beam shown below using **Virtual Work Method**. (Consider E and I as constant) 10

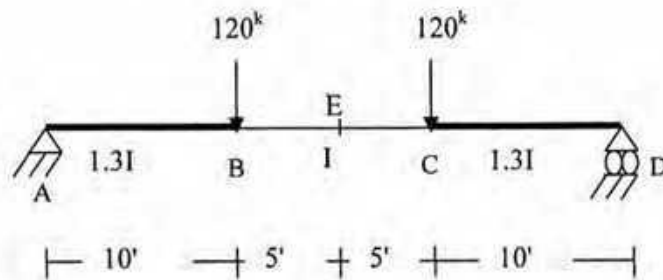

INTEGRATION RESULT

$I = \int m_1 m_2 dx$ Values

m_1	m_2	$\int m_1 m_2 dx$	$\int m_1 m_2 dx$	$\int m_1 m_2 dx$	$\int m_1 m_2 dx$	$\int m_1 m_2 dx$
		$\frac{A^2 l}{2}$	$\frac{A^2 l}{2}$	$\frac{A^2 l}{2}$	$\frac{(A+B)al}{2}$	$\frac{al}{6} \left[\frac{A^2}{2} + \frac{B^2}{2} + \frac{2AB}{2} \right]$
		$\frac{A^2 l}{3}$	$\frac{A^2 l}{3}$	$\frac{A^2 l}{6}$	$\frac{(A+2B)al}{6}$	$\frac{al}{6} (2B+C)$
		$\frac{A^2 l}{2}$	$\frac{A^2 l}{6}$	$\frac{A^2 l}{3}$	$\frac{(2A+B)al}{6}$	$\frac{(A+2B)al}{6}$
		$\frac{A(a+b)l}{2}$	$\frac{A(a+2b)l}{6}$	$\frac{A(2a+b)l}{6}$	$\frac{[A(2a+b)+B(2b+a)]l}{6}$	$\frac{[Aa+Cb+2B(a+b)]l}{6}$

$a \geq b$ or $a \leq b$

[a, b can be -ve or +ve]

The University of Asia Pacific
Department of Civil Engineering
Mid Term Examination Fall 2011
Program: B. Sc. Engineering (Civil)

SET B1

Course Title: Structural Engineering II
 Time: 1 hour

Credit Hours: 3.0

Course Code: CE 313
 Full Marks: 30

[Answer any 3 (Three) of the following 4 questions]

1. For the building frame shown below draw the Bending Moment Diagrams for the column ABC and girder DBE using **Portal Method**. 10

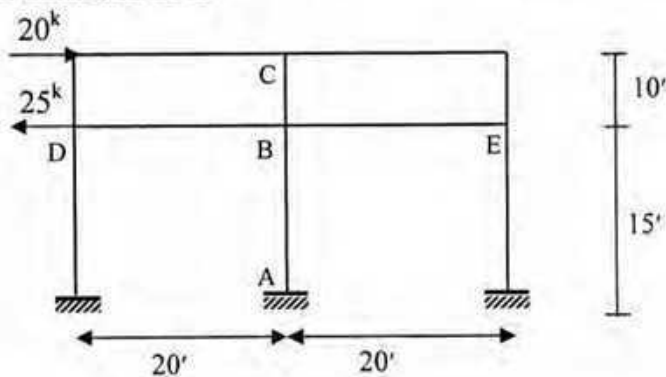

2. For the building frame shown below draw the Bending Moment Diagrams for the column ABC and girder DBE using **Cantilever Method**. 10

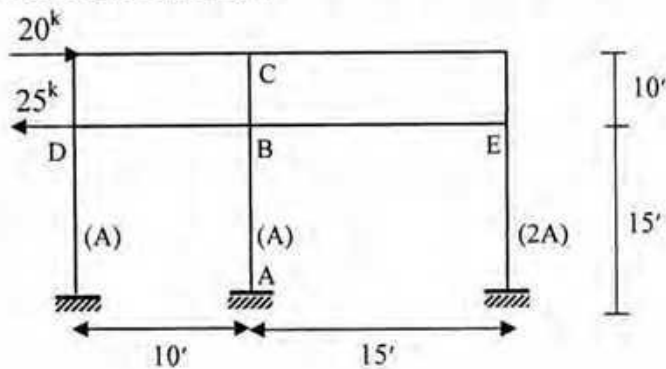

3. Determine the forces in members ab, bc, ad and ac of the truss shown in the figure below assuming that all members can carry both tension and compression. Use approximate method of analysis. 10

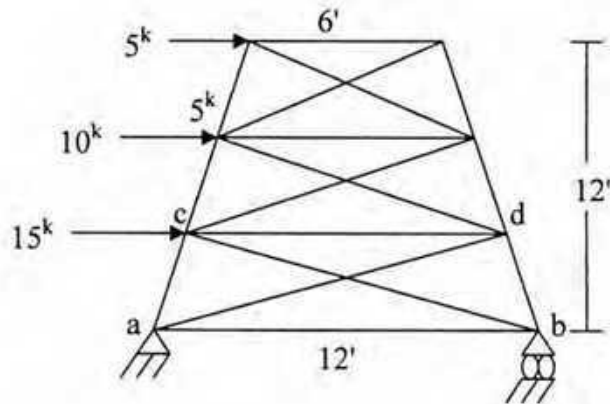

4. Determine the vertical deflection at location e of the beam shown below using **Virtual Work Method**. Consider E and I as constant. 10

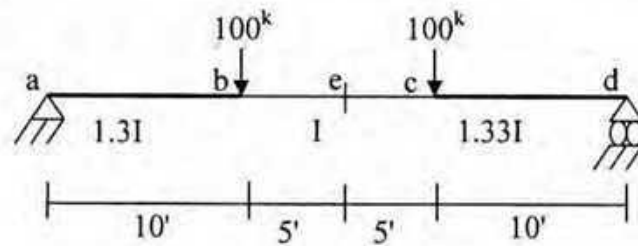

INTEGRATION RESULT

$I = \int m_1 m_2 dx$ Values

$m_1 \backslash m_2$	$\begin{array}{ c } \hline \Lambda \\ \hline \end{array}$ l	$\begin{array}{ c } \hline \Lambda \\ \hline \end{array}$ l	$\begin{array}{ c } \hline \Lambda \\ \hline \end{array}$ l	$\begin{array}{ c } \hline \Lambda \\ \hline \end{array}$ l	$\begin{array}{ c } \hline \Lambda \\ \hline \end{array}$ l
$\begin{array}{ c } \hline a \\ \hline \end{array}$ l	Aal	$Aal/2$	$Aal/2$	$(A+B)al/2$	$\frac{l/2 \quad l/2}{(A+4B+c)al/6}$
$\begin{array}{ c } \hline \Lambda \\ \hline \end{array}$ l	$Aal/2$	$Aal/3$	$Aal/6$	$(A+2B)al/6$	$(2B+C)al/6$
$\begin{array}{ c } \hline a \\ \hline \end{array}$ l	$Aal/2$	$Aal/6$	$Aal/3$	$(2A+B)al/6$	$(A+2B)al/6$
$\begin{array}{ c } \hline a \quad b \\ \hline \end{array}$ l	$A(a+b)l/2$	$A(a+2b)l/6$	$A(2a+b)l/6$	$\{A(2a+b)+B(2b+a)\}l/6$	$\{Aa+Cb+2B(a+h)\}l/6$

$a \geq b$ or $a \leq b$

The University of Asia Pacific
Department of Civil Engineering
Mid Term Examination Fall 2011
Program: B. Sc. Engineering (Civil)

SET B2

Course Title: Structural Engineering II
 Time: 1 hour

Credit Hours: 3.0

Course Code: CE 313
 Full Marks: 30

[Answer any 3 (Three) of the following 4 questions]

1. For the building frame shown below draw the Bending Moment Diagrams for the column ABC 10 and girder DBE using **Portal Method**.

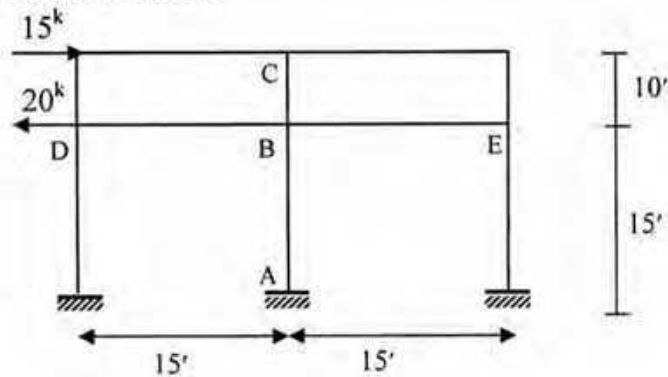

2. For the building frame shown below draw the Bending Moment Diagrams for the column ABC 10 and girder DBE using **Cantilever Method**.

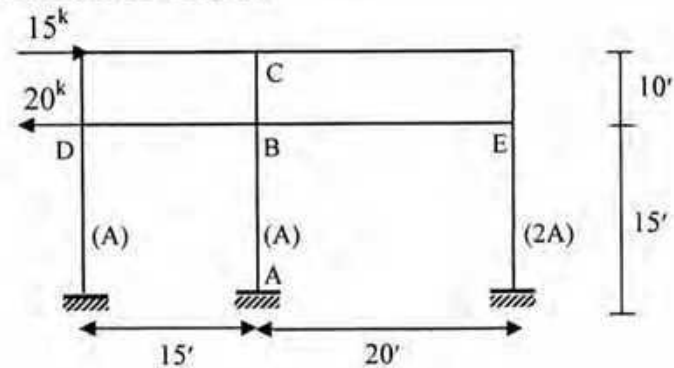

3. Determine the forces in members ab, bc, ad and ac of the truss shown in the figure below assuming that all members can carry both tension and compression. Use approximate method of analysis. 10

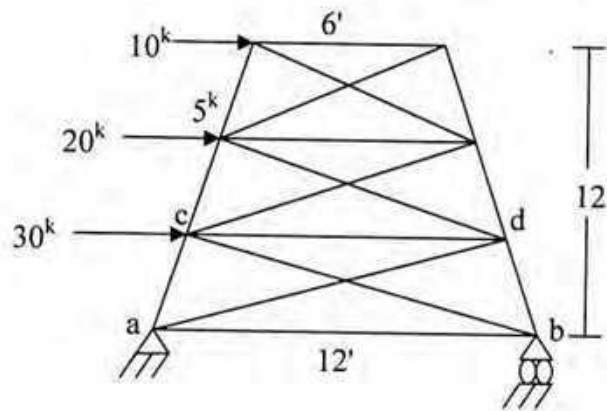

4. Determine the vertical deflection at location e of the beam shown below using **Virtual Work Method**. Consider E and I as constant. 10

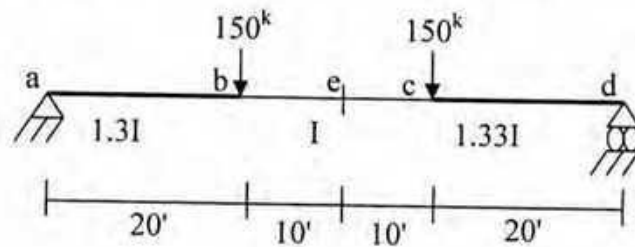

INTEGRATION RESULT

$I = \int m_1 m_2 dx$ Values

$m_1 \backslash m_2$	$\Delta \begin{array}{ c } \hline \square \\ \hline l \end{array}$	$\begin{array}{ c } \hline \triangle \\ \hline l \end{array} \Delta$	$\Delta \begin{array}{ c } \hline \triangle \\ \hline l \end{array}$	$\Delta \begin{array}{ c } \hline \square \\ \hline l \end{array} B$	$\begin{array}{ c } \hline \text{parabola} \\ \hline l \end{array}$
$\begin{array}{ c } \hline \square \\ \hline l \end{array} a$	Aal	$Aal/2$	$Aal/2$	$(A+B)al/2$	$\frac{l/2 \quad l/2}{(A+4B+c)al/6}$
$\begin{array}{ c } \hline \triangle \\ \hline l \end{array} a$	$Aal/2$	$Aal/3$	$Aal/6$	$(A+2B)al/6$	$(2B+C)al/6$
$\begin{array}{ c } \hline \triangle \\ \hline l \end{array} a$	$Aal/2$	$Aal/6$	$Aal/3$	$(2A+B)al/6$	$(A+2B)al/6$
$\begin{array}{ c } \hline \square \\ \hline l \end{array} a \quad b$	$A(a+b)l/2$	$A(a+2b)l/6$	$A(2a+b)l/6$	$\{A(2a+b)+B(2b+a)\}l/6$	$\{Aa+Cb+2B(a+b)\}l/6$

$a \geq b$ or $a \leq b$

University of Asia Pacific
Department of Civil Engineering
Mid Semester Examination Fall 2011 (Set A)

Course #: CE 315
 Full Marks: 100

Course Title: Design of Concrete Structures I
 Time: 1 hour

There are FOUR questions. Answer ALL questions.

■ **Question 1:**

(a) Explain why strength reduction factor (ϕ) is needed.	(4)
(b) Explain why minimum reinforcement ratio (ρ_{minimum}) is needed.	(4)
(c) Draw qualitative design strain diagram for over-reinforced beam, under-reinforced beam and beam at balanced condition.	(4)

■ **Question 2:**

For the beam section (shown in Figure 1), the following moment capacities are found at different stages of loading

$$M_{\text{cracking}} = 65.49 \text{ kip-ft}$$

$$M_{\text{allowable}} = 161.81 \text{ kip-ft}$$

$$M_{\text{ultimate}} = 361.06 \text{ kip-ft}$$

(20)

If a moment of 100 kip-ft is applied to the section, determine the concrete stress at top fiber and bottom fiber, and steel stress [Given: $f'_c = 4000$ psi, $f_y = 60000$ psi, $f_r = 475$ psi].

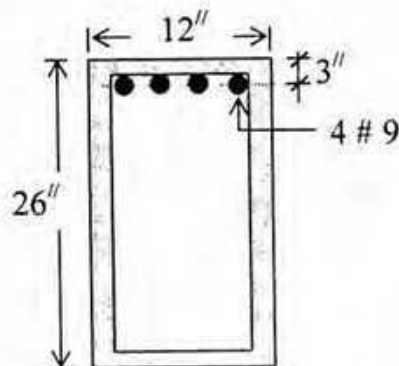

Figure 1 (for Question 2)

■ **Question 3:**

Design a singly reinforced beam (on a simply supported span of 18 feet) to support at DL of 1.50 kip/ft (excluding self weight) and LL of 2.50 kip/ft (see Figure 2), using steel ratio $\rho = \frac{5}{8} \rho_b$

(34)

[Given: $f'_c = 4000$ psi, $f_y = 60000$ psi, beam width $b = 12$ inch].

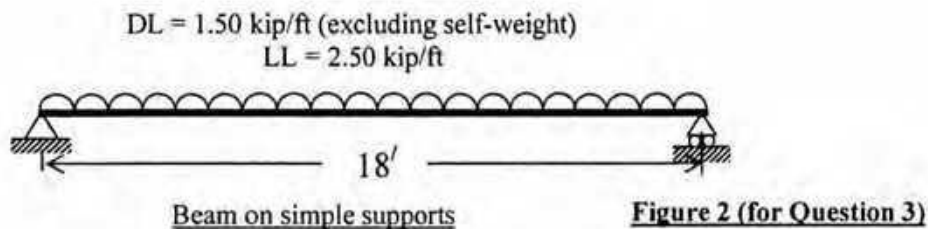

■ **Question 4:**

A designer selects the following beam section at mid-span of a simple span of 14.50 feet to support a dead load of 2 kip/ft (excluding self-weight) and live load of 3 kip/ft (see Figure 3).

(34)

Check the adequacy of the beam section (whether it is OK or not)

[Given: $f'_c = 3000$ psi, $f_y = 40000$ psi].

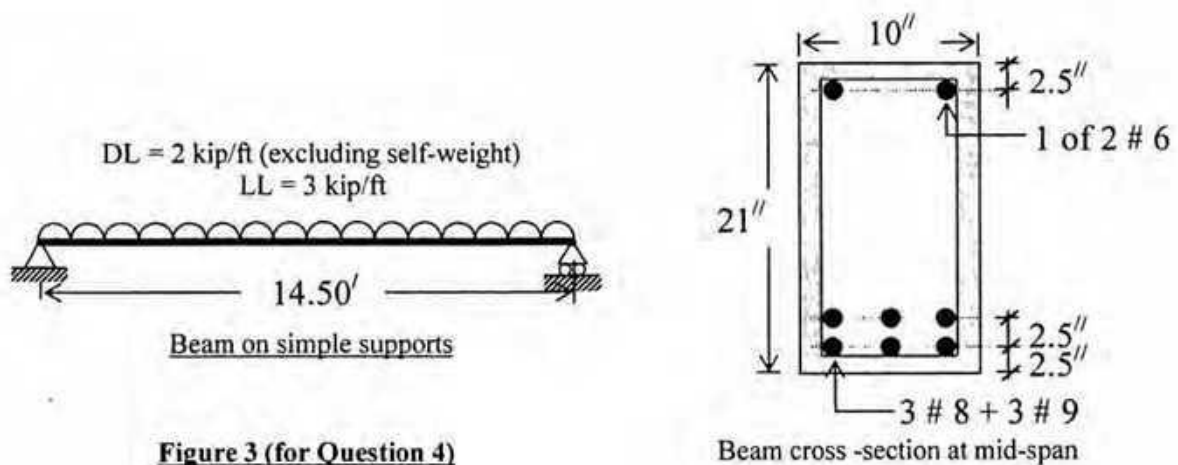

The University of Asia Pacific
Department of Civil Engineering
Mid Semester Examination Fall 2011
Program: B. Sc. Engineering (Civil)

Course Title: Design of Concrete Structures II Credit Hours: 3.0
 Time: 1 hour

Course Code: CE 317
 Full Marks: 60 [20×3=60]

There are **FOUR** Questions. Answer any **THREE** Questions.

[20]

[Given: $f'_c = 3$ ksi, $f_y = 50$ ksi, $f_s = 20$ ksi, $j = 0.874$, $R_{(wsd)} = 0.223$ ksi, $R_u = 0.739$ ksi for all problems]

1. Refer to the following slab system a building:

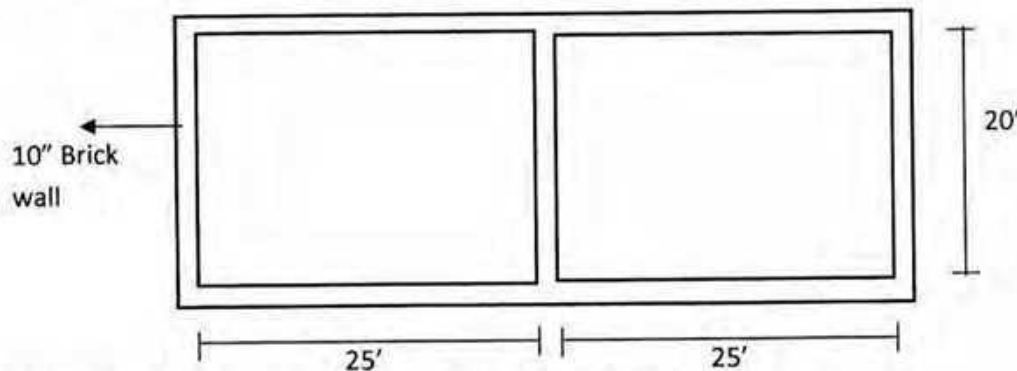

LL = 60 psf, partition wall = 50 psf, floor finish = 20 psf,

Design the slab by **WSD** or **USD** . Follow the steps mentioned below:

- (i) Calculation for minimum slab thickness
- (ii) Determination of moment coefficients and calculation for design moments
- (iii) Check for slab thickness to avoid compression failure of concrete
- (iv) Calculation for flexural reinforcements
- (v) Check for temperature and shrinkage reinforcements
- (vi) Neat sketches of reinforcements (including corner reinforcement) (plan and one section)

Tables for moment coefficients are attached.

2. (a) In reviewing the capability of a building, a particular column of the same existing framed building is found to be reinforced with bars as shown below. The service loads calculated for different load combinations are found as follows: [16]

- (i) $P = 550$ k and $M = 200$ k-ft
 or (ii) $P = 225$ k and $M = 300$ k-ft

For each case, check the adequacy of the column section by **WSD** method.

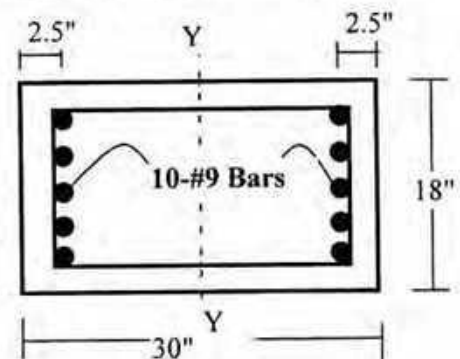

2.(b) "Strength reduction factor (ϕ) for columns is considerably lower than those for flexure or shear" - Why? [04]

3. (a) Design a tied column supporting a DL=600 k and LL=400 k assuming a moderate % of steel by WSD. [6+6+6+2]

(b) Keeping the same Cross-section as in (a) design the same column by USD.

(c) Keeping the actual % of steel as in (a) design the column by USD

(d) Give comments on your results.

4. An isolated square footing of size **11 ft by 11ft** is planned under a column with the following data: [20]

Column size = 18 in. by 18 in.

Column reinforcements = 8 - #8 bars

DL = 400 kips, LL = 200 kips, Depth of Foundation, $D_f=5$ ft

Design the footing by USD.

Follow the steps mentioned below:

- (i) Check for punching shear
- (ii) Check for beam shear
- (iii) Calculation for design moment and check for footing thickness
- (iv) Calculation for reinforcements
- (v) Check for development length of bar
- (vi) Neat sketches of reinforcements (plan and sections)

University of Asia Pacific
Department of Civil Engineering
Mid Semester Examination Fall 2011
Program: B.Sc. Engineering (Civil)

Course Title: Environmental Engineering I Course Code: CE 331 Credit: 2.00
 Time- 1 hour Full marks: 60

There are **FOUR** questions. Answers any **THREE**. (3 X 20 = 60)

1. (a) Describe the elements of water supply. (8)
- (b) Table shows the population of a country during the years 1870- 1970, in ten years intervals. (a) Find the equation of the least square parabola fitting the data. (b) Compute the trend values for the years in the table below and compare with the actual values. (c) Estimate the population of the community in the year 1980 and 1990. (10)

Year	1870	1880	1890	1900	1910	1920	1930	1940	1950	1960	1970
Pop ⁿ (million)	23	31	39	50	62	76	92	105	122	131	151

- (c) Write down the advantages of use the well screen. (2)
2. (a) Describe with figures the flow towards well. (6)
- (b) Also show that the ground water yield of a confined aquifer , can be expressed as , (5+2)
- $$Q = \{2\pi km(D-d)\} / \{\log_e(R/r)\}$$
- (c) A 100 mm diameter tubewell is sunk 35 m below static groundwater level. The probable discharge of the well is 33.4 lps. The radius of drawdown is 30 m and the coefficient of permeability of the aquifer is 0.5 l/s/m². Calculate the depth of water in the tubewell while pumping. (7)
3. (a) How the screen transmitting capacity of a well can be expressed? Write the design specification for slot openings for well screen. (2.5+3.5)
- (b) The population of a town was 180,000 in 1980 and 220,000 in 1990. What will the population be in 2000? (4)

- (c) Find out the slot size of the screen and intake areas of screen openings for the defined slot openings of a well from the following data: (5+5)

Thickness of the aquifer	= 60 ft
Discharge	= 334 gpm
Entrance velocity	= 0.1 fps
Well diameter	= 2 inch
Length of the screen	= 43 ft.

4. (a) Define the following terms: Efficient size (D_{10}), Uniformity coefficient (C_U), and Mean particle size (D_{50}) of the aquifer. (5)

- (b) Write down the installation procedure of tubewells. (7)

- (c) Design a suitable set of pumping unit to deliver raw water from an intake well of a river bank to the treatment plant. It is required to pump water at the rate of 4,50,000 gph from the well whose surface is at an elevation of 185 ft. to a tank whose top is at an elevation of 245 ft. The pump is placed at an elevation of 195 ft. The velocity of water is 12 fps. The total length of rising main from the intake well to the treatment plant is 800 ft. What is the required horsepower of a pump for which the overall efficiency is 70%? (8)
(Assume, friction factor = 0.0075)

University of Asia Pacific
Department of Civil Engineering
Mid Term Examination-Fall 2011
Program: B.Sc. Engineering (Civil)

Course No: CE 333

Course Title: Environmental Engineering II (Waste Water Engineering)

Time: 60 min

Full Marks: 60

[Answer all the questions]

[Assume reasonable value for missing data (if any)]

1. Calculate the wastewater quantity (m^3/day) of a small town of **60,000** inhabitants. (7)
The average water consumption is **150 l/day/capita**. A small factory locates in the town, has a daily production capacity of **7200 kg**. Each kg produced wastewater in average as much as **1.7** inhabitants. A hotel along with other commercial area occupied **200 ha** producing **1.0 l/sec/ha** wastewater.
2. Design a septic tank for a family of **10** persons with a desludging interval of **5** years. (14)
The average wastewater flow is **15 litres per capita per day**. Also design the soak pit for the disposal of septic tank effluent. The soil is silty loam with a long term infiltration rate of **20 l/m²-day**. Draw a neat sketch for septic tank and soak pit.
3. Design a simple pit latrine for a family of **10** persons for a design life of **4** years. (12)
GWT is **3.5 m** below ground surface. After using the latrine for **1.5** years, the users want to upgrade the latrine into an off-set pit latrine (similar to ROEC) so that the same pit can be used repeatedly with regular desludging. Determine total life of the pit as an off-set pit before emptying for the first cycle.
4. Determine the velocity in a **30 cm** circular sewer with $n = 0.013$, slope $S = 0.004$ (10)
m/m and depth of flow equal to **7.5 cm**.
5. Define the following terms: (i) Sullage, (ii) Sewer, (iii) Sewerage and (iv) Sewage (4)
6. What are the factors on which groundwater infiltration in a sewer depends on? (4)
7. Show diagrammatically the effect of sanitation on disease transmission. (5)
8. What are the criteria for good sanitation? (4)

Formulae

$$V_{sc} = 0.4 V_{sl}$$

$$V_h = 10^{-3} P q t_h$$

$$t_d = 30 * (1.035)^{35-T}$$

$$t_h = 1.5 - 0.3 \log (Pq)$$

$$V_d = 0.5 * 10^{-3} P t_d$$

$$V_{sl} = C P N$$

$$d_{sc} = 0.82 - 0.26 A$$

$$V_p = 1.486/n * R^{2/3} S^{1/2}$$

University of Asia Pacific

Department of Civil Engineering

CE 341 Geotechnical Engineering I

Fall 2011 Midterm Examination

Answer three from the following:

1. (a) What is weathering? What are the factors controlling weathering processes?
(b) In which triaxial test soil fails at an equal deviator stress for the different cell pressure and why?
(c) A cylindrical specimen of a saturated soil fails at an axial stress of 167 kN/m² in an unconfined compression test. The failure plane makes an angle of 35° with the horizontal. Calculate the shear strength parameters.

2. (a) Briefly discuss on different soil structures.

(b) Draw the mohr circles and failure envelopes (total and effective stresses) for a typical cohesive soil in CU triaxial test. Show total and effective stress parameters in the figure.

(c) Classify the given soil according to Unified Soil Classification System. Given that

Percent finer than 4.75 mm = 96

Percent finer than 2 mm = 60

Percent finer than 0.425 mm = 30

Percent finer than 0.075 mm = 10

The liquid limit and plasticity index of soil fraction finer than 0.425 mm are 40 % and 20 %, respectively.

3. (a) Describe Cassagrande's Method of determining liquid limit.
- (b) Briefly discuss on important field identification tests of soil.
- (c) Draw the typical shapes of particle size distribution curves for the following:
- (i) Well graded sand, (ii) Poorly graded sand, (iii) Gap graded sand
- (d) Define: (i) Uniformity coefficient, (ii) Effective Size
4. (a) Define: (i) Activity of soil; (ii) Plasticity Index;
- (b) Briefly discuss on soil consistency tests.
- (c) For a given soil, the following data are known:
- 60 % of the soil passing # 4 sieve;
- 30 % of the soil passing # 40 sieve;
- 10 % of the soil in the pan;
- (i) What is the effective size of the soil?
- (ii) If the soil is sieved with a standard sieve having 0.425 mm opening size, how much soil will retain?
- (iii) Identify the type of soil based on particle size distribution.

The University of Asia Pacific
Department of Civil Engineering
Mid-Term Examination Fall' 2011

Course No: CE3451
 Full Marks: 60

Course Title: Transportation Engineering I
 Time: 1 hour

Answer ALL:

1. If a highway curve with a radius of 800 ft has a super elevation rate of 6% then what will be the maximum safe operating speed on that? (10)
2. An accident investigator estimates that a vehicle hit a bridge abutment at a speed of 15 mph based on her assessment of the damage. Leading up to the accident location, she observes skid mark of 150 ft. on the pavement and 75 ft on the grass shoulder. The whole section is on a 3% grade. What was the speed of the vehicle before it applied break? Use $F = 0.35$ and 0.25 – for the two surface conditions (use your judgment to select the values). (10)
3. What is PCE? Give a mathematical example to demonstrate its use in traffic engineering. (10)
4. Draw a diagram and identify different parts (mentioning their names) of a spiral curve. Minimum how far can you place an object on a horizontal curve from the center of the curve? (10)
5. Draw cross sections of 5 types of guard rails and mention where these can be applicable? (10)
6. What is DDHV? What are “K” and “D” factors? What will be there typical values for urban areas? What is PHF? What will be its theoretical maximum and minimum values? Demonstrate mathematically. (10)

Table 2.4: Coefficient of Side Friction (f) for Wet Pavements at Various Speeds

Speed (mi/h)	30	40	50	60	70
f	0.16	0.15	0.14	0.12	0.10

$$R = \frac{S^2}{15(0.01e + f)} \quad d_b = \frac{S_i^2 - S_f^2}{30(0.348 \pm 0.01G)}$$

$$d_a = \left(\frac{1.47 S}{a} \right) * \left(\frac{1.47 S}{2} \right) = 1.075 \left(\frac{S^2}{a} \right)$$

University of Asia Pacific
Midterm Exam
Open Channel Hydraulics
CE 361
Full Marks: 60

1. (a) Why the velocity distribution coefficients are necessary? In a wide river, the velocity varies along a vertical as $u = 1+2z/h$, where h is the total depth and u is the velocity at a distance z from the channel bottom. The river is 5 m deep. Compute the velocity distribution coefficients. (10)
- (b) For curvilinear flow, prove that total pressure head = pressure due to centrifugal action and weight of the water column. (10)
- (c) State when hydrostatic pressure distribution is valid. (5)
- (d) Describe with appropriate sketch, the various forces acting in the momentum equation for one dimensional steady flow. (5)
2. (a) Prove that for critical state of flow and for rectangular channel, specific energy = 1.5* critical depth of flow. (5)
- (b) Describe specific energy curve and from the specific energy curve prove that $F_r = 1$. (10)
- (c) For a trapezoidal channel with $b= 6$ m and side slope 1H:2V, compute the critical depth and velocity if $Q = 50$ m³/s. $\alpha = 1$. (10)
- (d) Differentiate between specific energy and total energy. (5)

UNIVERSITY OF ASIA PACIFIC
DEPARTMENT OF CIVIL ENGINEERING
MID SEMESTER EXAMINATION, FALL 2011

Course Title: Hydrology
Time: 1 hour

Credit Hours: 3.0

Course Code: CE 363
Full Marks: 60

(Answer All Question)

1. (a) Write short notes on: (2 × 3=6)

- i. Orographic storms
- ii. Pan Coefficient

(b) Define followings (4 × 2=8)

- i. Potential Evapotranspiration
- ii. Field Capacity
- iii. Permanent Wilting Point
- iv. Hydrostatic Pressure law

(c) The infiltration rate at the beginning of a storm was 4.0 in/h and it decreased to constant rate 0.53 in/h after two hours. A total of 1.0 inch infiltrated during those two hours. Determine the value of k for Horton's equation? (6)

2. (a) Four raingauges located within a rectangular area with four corners at (0,0), (0,8), (16,8) and (16,0) have the following coordinates and rainfalls; (14)

Raingauge location	Rainfall (cm)
(0,0)	3.3
(8,0)	4.4
(8,8)	6.6
(16,0)	3.3

All Coordinates are expressed in km. Compute the average rainfall in the area by the Thiessen method.

(b) A storm with 5.0cm precipitation produced a direct runoff of 1.7cm. Time distribution of 8hrs consecutive storm is as follows; estimate the Φ index of the storm. (6)

Time from start (h)	1	2	3	4	5	6	7	8
Incremental rainfall in each hour(cm)	0.2	0.3	0.55	1.0	1.5	0.9	0.45	0.1

3. (a) Discuss the factors that affect the process of Evaporation? (8)

(b) Discuss water budget method of estimating evaporation from lake with neat sketch? (5)

(c) A reservoir with a surface area of 250 hectares' had the following average values of parameters during a week; (7)

Water temperature = 20°C

Relative humidity = 40%

Wind velocity at 1.0m above ground = 16 km/hr

Estimate the average daily evaporation from the lake and the volume of water evaporated from the lake during that one week?

University of Asia Pacific
Department of Civil Engineering
Mid Term Examination Fall 2011
Program : B.Sc Engineering (Civil)

Course Title: Project Planning and Management
 Time: 1:00 hrs

Course Code: CE 401
 Full Marks: 20

There are THREE Questions answer any TWO
 (Graph sheet should be supplied)

1. (a) Discuss the relation between NPV and IRR of a project for different values of discount rate. (2)
- (b) The Farmer's American Bank of Leesburg is planning to install a new computerized accounts system. Bank management has determined the activities required to complete the project, the precedence relationships of the activities are as follows: (8)

Activity	Description	Activity Predecessor	Time (Weeks)
A	Position recruiting	-----	4
B	System development	A	3
C	System training	A	5
D	Equipment training	A	3
E	Manual system test	B,C	5
F	Preliminary system changeover	C	6
G	Computer-personal interface	D	5
H	Equipment –modification	E	4
I	Equipment testing	F,G	5
J	System debugging and installation	H,I	7

- A. Draw the AON network diagram
- B. Find the project completion time
- C. Find the critical path
- D. Find ES/EF and LS/LF for each of the activity
- E. If you reduce the time required for activity D & E by 1 week each, find the project completion time and critical path as well.

2. (a) What is Redundant constraint in Linear Programming? Explain its significance. (2)

(b) Objective function: (8)

$$\text{Maximize } Z = x_1 + 0.5x_2$$

Constrains:

$$3x_1 + 2x_2 \leq 12$$

$$5x_1 \leq 10$$

$$x_1 + x_2 \leq 8$$

$$-x_1 + x_2 \geq 4$$

$$x_1, x_2 \geq 0$$

- i. Find the feasible area by Graphical Method
- ii. Find the optimum value of X_1 and X_2 .
- iii. Find maximum profit
- iv. Find the range of optimality for x_1 and x_2 separately.

3. (a) Suppose you have 1,00,000/- for investment and Project A and Project B is offering the repayment schedule as shown in the following cash flow: (7)

Year	Cash flow of Project A	Cash flow of Project B
0 (investment)	1,00,000/-	1,00,000/-
1	50,000/-	20,000/-
2	30,000/-	20,000/-
3	20,000/-	20,000/-
4	10,000/-	40,000/-
5	10,000/-	50,000/-
6		60,000/-

You can earn a total 1,20,000/- in 5 years from project A and earn a total of 2,10,000/- in 6 years from project B as shown in the above table. Find the NPV, BCR and Discounted Pay Back Period for each of the project. Also make comments on the result in respect to investment decision. Consider 10% annual interest/discount rate.

(b) Discuss the activities associated with different stages of Project life cycle. (3)

University of Asia Pacific
Department of Civil Engineering
Mid Semester Examination Fall 2011

Course #: CE 403

Course Title: Professional Practices and Communication

Full Marks: 40 (= 5 × 8)

Time: 1 hour

Answer any 5 (Five) Questions

1. (a) Define Project. [0.5]
(b) Write down the objectives of a Project. [1.5]
(c) What are the characteristics of a Project? [6]

2. (a) Write a brief introduction of MDG. [2]
(b) What are the goals of MDG? [6]

3. Write a short note on the Project Preparation of Padma Multipurpose Bridge in chronological order from the year 2000. [8]

4. Write down the stages of public procurement according to PPA 2006. [8]

5. Write down the sequence of preparing the rough estimate of a project. [6]
Show the sequence in a diagram. [2]

6. (a) What is DPP? [1]
(b) Write down different stages of DPP. [3]
(c) What are the necessities of preparing DPP? [4]

University of Asia Pacific
Department of Civil Engineering
Mid Semester Examination Fall 2011
Program: B. Sc. Engineering (Civil)

Course Title: Structural Engineering III Credit Hours: 3.0
 Time: 1 hour

Course Code: CE 411
 Full Marks: 40 (= 4 × 10)

1. In the truss shown below, calculate the
 (i) force in all members, (ii) applied loads F_1 , F_2 , and (iii) horizontal and vertical deflections at joint a ,
 if the applied loads cause both joints b and c to move 0.10' upward
 [Given: $EA/L = \text{constant} = 500 \text{ k/ft}$].

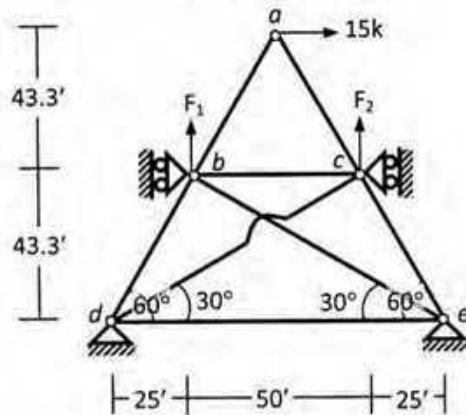

2. Use the Stiffness Method (with flexural deformations only) to calculate the vertical deflection at joint C and rotation at joint B of the frame shown below [Given: $EI = \text{constant} = 40 \times 10^3 \text{ k-ft}^2$].

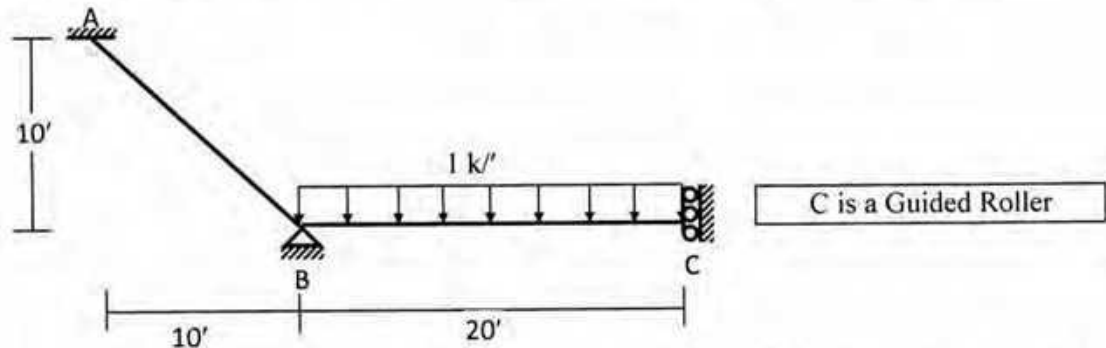

3. Use the Stiffness Method neglecting axial deformations to calculate the deflection at A and rotation at C of the beam shown below, if support B settles 1" downward [Given: $EI = 40 \times 10^3 \text{ k-ft}^2$].

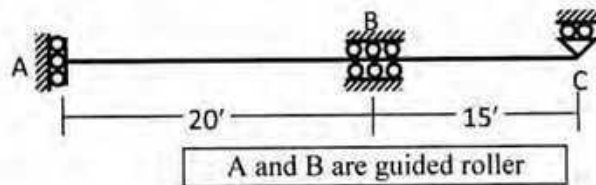

4. In the three-dimensional truss ABCD shown below, ignore the zero-force members and formulate the stiffness matrix, load vector and write down the boundary conditions
 [Given: $EA/L = \text{constant} = 1000 \text{ kip/ft}$].

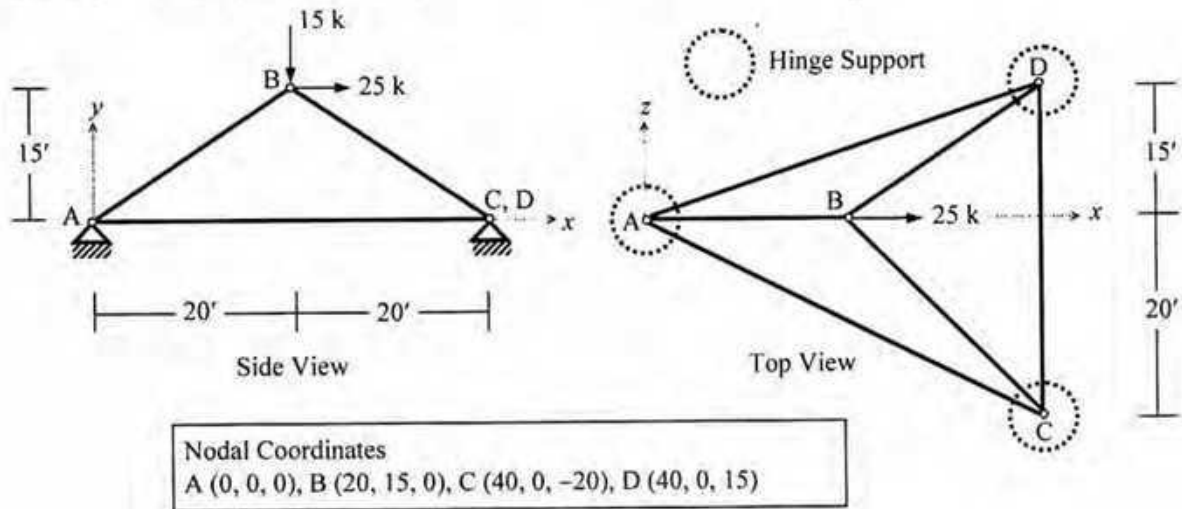

University of Asia Pacific
Department of Civil Engineering
Mid Semester Examination Fall 2011
Program: B. Sc. Engineering (Civil)

Course Title: Structural Engineering III Credit Hours: 3.0
 Time: 1 hour

Course Code: CE 411
 Full Marks: 40 (= 4 × 10)

1. In the truss shown below, calculate the
 (i) force in all members, (ii) applied loads F_1 , F_2 , and (iii) horizontal and vertical deflections at joint a ,
 if the applied loads cause both joints b and c to move 0.10' upward
 [Given: $EA/L = \text{constant} = 500 \text{ k/ft}$].

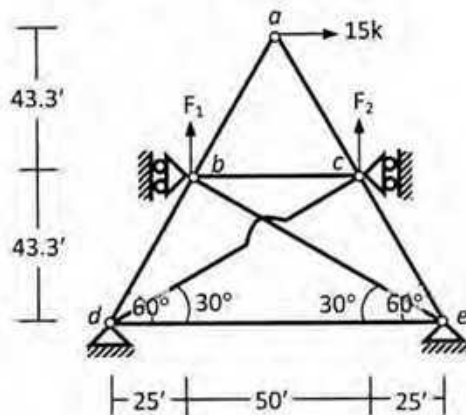

2. Use the Stiffness Method (with flexural deformations only) to calculate the vertical deflection at joint C and rotation at joint B of the frame shown below [Given: $EI = \text{constant} = 40 \times 10^3 \text{ k-ft}^2$].

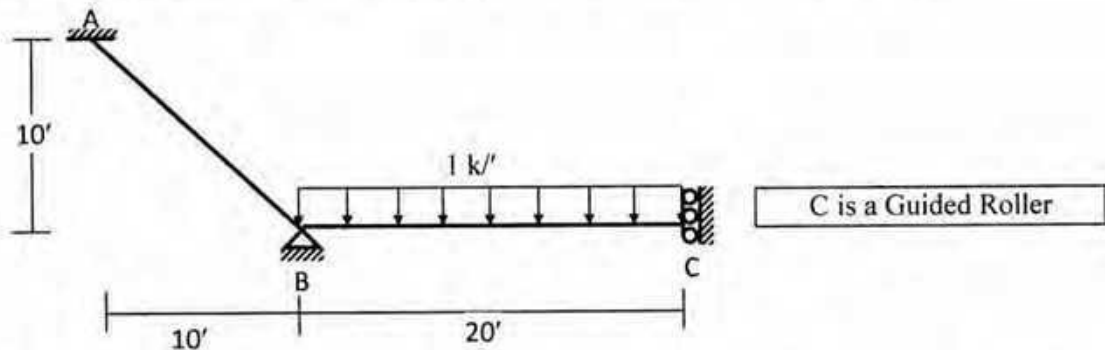

3. Use the Stiffness Method neglecting axial deformations to calculate the deflection at A and rotation at C of the beam shown below, if support B settles 1" downward [Given: $EI = 40 \times 10^3 \text{ k-ft}^2$].

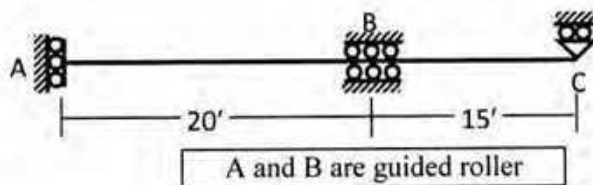

4. In the three-dimensional truss ABCD shown below, ignore the zero-force members and formulate the stiffness matrix, load vector and write down the boundary conditions
 [Given: $EA/L = \text{constant} = 1000 \text{ kip/ft}$].

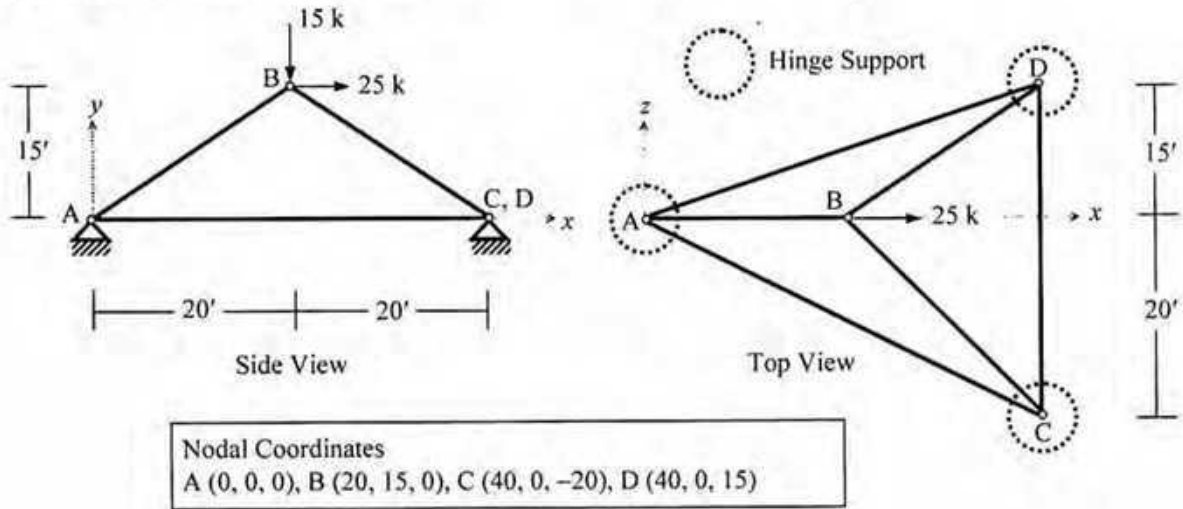

The University of Asia Pacific
Department of Civil Engineering
Mid Term Examination Fall 2011
Program: B. Sc Engineering (Civil)

Course Title: Structural Engineering V Course Code: CE 415
 Time: 1.00 Hour

Credit: 2.00
 Full Marks: 40

Answer any 2 (two) questions

1. (a) Calculate the % loss of prestress in the beam shown below due to friction for tensioning is done from one end. Solve this problem using more exact expression. Given $K=0.0026/m$, $\mu=0.3$
 [Formula: $F_2 = F_1 e^{-(KL + \mu\alpha)}$] [10]

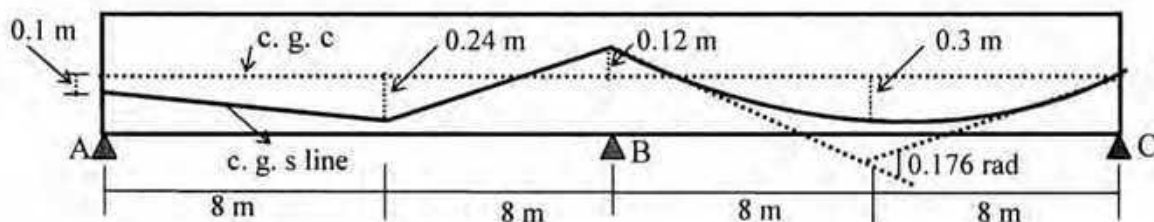

(b) Mention the ACI specification for stress in concrete and steel for prestressed concrete at
 (i) Initial case (ii) Service condition [04]

(c) Discuss the variation of steel stress in bonded and unbonded member under various stages of loading. Explain with sketches. [06]

2.a) A prestressed concrete sleeper produced by pre-tensioning method has a rectangular cross-section of 300 mm × 250 mm ($b \times h$). It is prestressed with 9 numbers of straight 7 mm diameter wires at 0.8 times the ultimate strength of 1570 N/mm². Using transformed area; estimate the percentage loss of stress due to elastic shortening of concrete. Consider $n = 6$ [16]

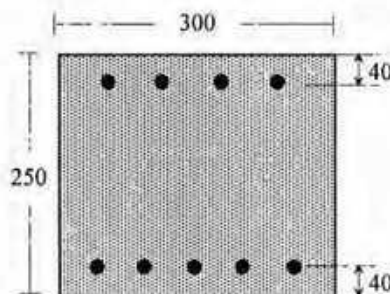

b) Give a list of sources of losses (mention percentages) in prestressed concrete [04]

3. (a) A prestressed concrete beam 500 mm by 750 mm has a simple span of 7.30m and loaded by a uniform load of 45 kN/m including its own weight. The prestressing tendon produces an effective prestress of 1620 kN. Compute fibre stresses in the concrete at the midspan section. Use the 1st concept. [16]

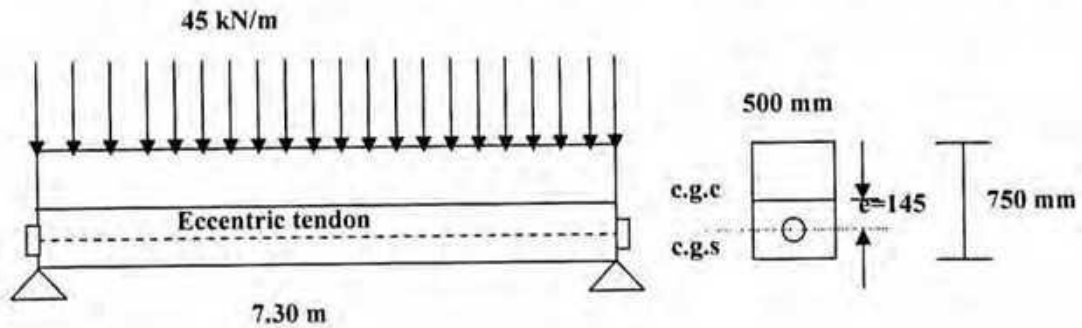

(b) Discuss the different forms of prestressing steel [04]

Appendix

Table: Values of K_{re} and J

Type of Tendon	K_{re} (Mpa)	J
1860 MPa Grade stress-relieved strand or wire	138	0.15
1720 MPa Grade stress-relieved strand or wire	128	0.14
1655 MPa or 1620 MPa Grade stress-relieved wire	121	0.13
1860 MPa Grade low-relaxation strand	35	0.040
1720 MPa Grade low-relaxation s wire	32	0.037
1655 MPa or 1620 MPa Grade low-relaxation strand wire	30	0.035
1000 MPa or 1100 MPa Grade stress-relieved bar	41	0.05

Table: Values C

f_{pi}/f_{pu}	Stress relieve strand and wire	Stress relieved bar or low relaxation strand or wire
0.80		1.28
0.79		1.22
0.78		1.16
0.77		1.11
0.76		1.05
0.75	1.45	1.00
0.74	1.36	0.95
0.73	1.27	0.90
0.72	1.18	0.85
0.71	1.09	0.80
0.70	1.00	0.75
0.69	0.94	0.70
0.68	0.89	0.66
0.67	0.83	0.61
0.66	0.78	0.57
0.65	0.73	0.53
0.64	0.68	0.49
0.63	0.63	0.45
0.62	0.58	0.41
0.61	0.53	0.37
0.60	0.49	0.33

The University of Asia Pacific
Department of Civil Engineering
Mid-term Examination Fall' 2011

Course No. & Title: CE 417 Structural Engineering VI (Design of Steel Structures)

Full Marks: 40 Time: 1 hour

The figures in the margin indicate full marks.

Assume reasonable values for any missing data.

There are FOUR questions. Answer any THREE questions.

1. (a) Drawing a stress-strain diagram for high carbon steels, not exhibiting a pronounced yield point, show in neat sketch how yield strength may be determined in such cases. 3 1/3
- (b) Explain the phenomenon of strain aging with neat sketches 3
- (c) Classify steel for structural purposes. 2
- (d) With sketches briefly discuss different available structural shapes and their identification. 5

2. Using AISC/LRFD method, determine the design strength (capacity) for failure by tearing through the free edges of the joint shown in Fig.2. The load is to be transmitted through two C9x20 to a 1-in. gusset plate. All material is A36. Bolts are 1-in. diameter A325 in standard holes in a bearing-type connection. Given: thickness of web of a channel = 0.448 inch. 13 1/3

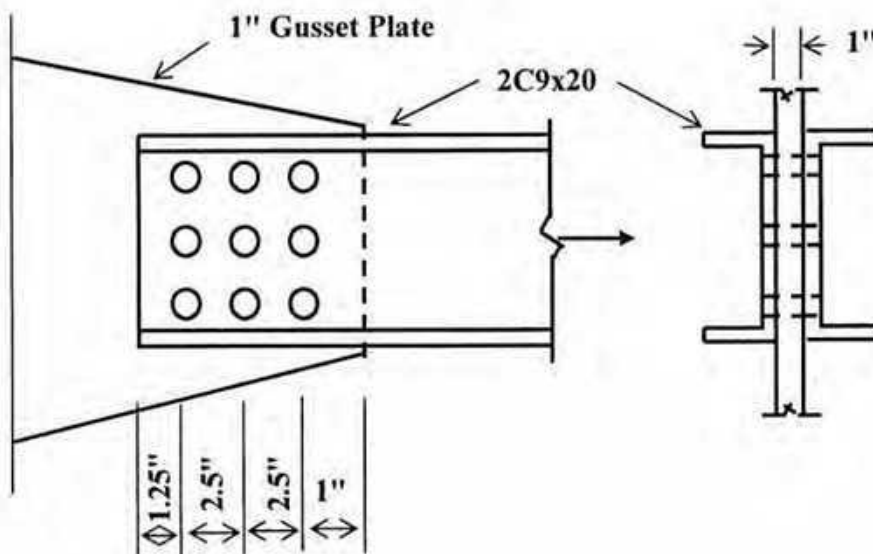
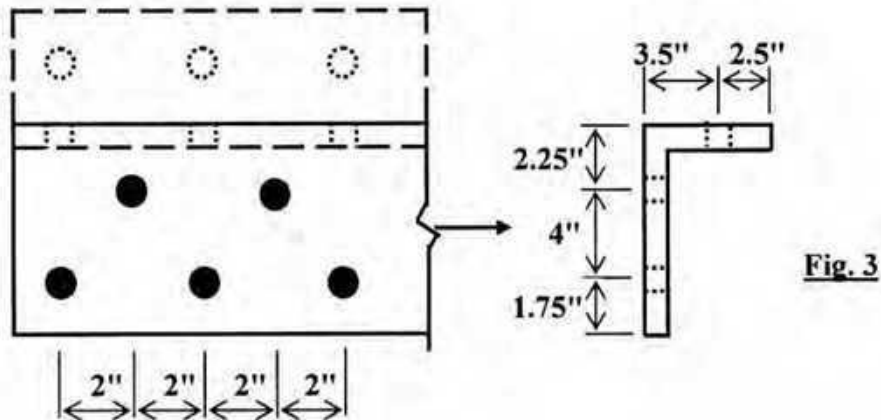
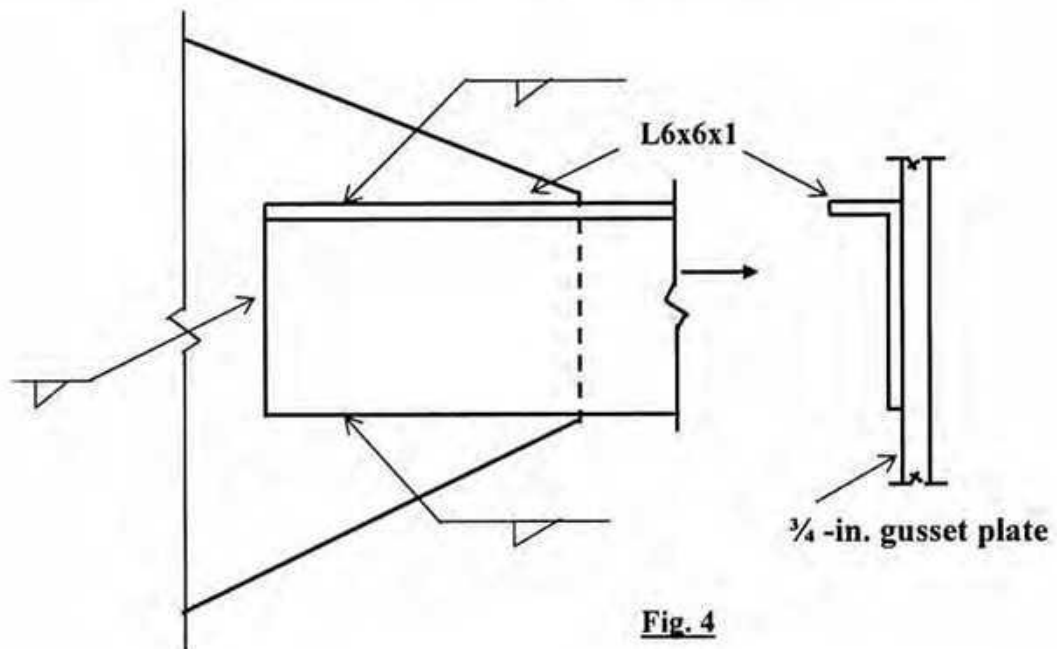

Fig. 2

3. A 8x6x1-in. angle is connected by two rows of 7/8-in. bolts in the 8-in. leg and one row in the 6-in. leg (staggered as shown in Fig. 3) in standard holes. Determine the net areas for the angle and also calculate the allowable load in tension using AISC/ASD method. Given: $A_g = 13 \text{ in}^2$ for the angle; $U = 0.85$; Angle is of A36 steel. 13 1/3



4. Using AISC/LRFD method, design and detail the welded end connection required to transmit a dead load force of 40 kips and a live load force of 150 kips through an angle L6x6x1 inch to a 3/4-inch gusset plate (Fig. 4). All material is A36. Welds are to be deposited manually using E60XX electrodes. Use weld size 5/16-inch in the design; Resistance Factor = 0.75; Nominal strength for weld = 0.6 times the nominal tensile strength of weld metal. Annexure-1 is provided to facilitate the design. 13 1/3



ANNEXURE-1

ANGLES
Equal legs and unequal legs
Properties for designing

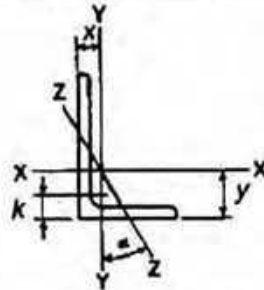

Size and Thickness	k	Weight per Ft	Area	AXIS X-X				AXIS Y-Y				AXIS Z-Z	
				I	S	r	y	I	S	r	x	r	Tan α
In.	In.	Lb.	In. ²	In. ⁴	In. ³	In.	In.	In. ⁴	In. ³	In.	In.	In.	
L 6×6 ×1	1½	37.4	11.0	35.5	8.57	1.80	1.86	35.5	8.57	1.80	1.86	1.17	1.000
¾	1¾	33.1	9.73	31.9	7.63	1.81	1.82	31.9	7.63	1.81	1.82	1.17	1.000
¾	1¼	28.7	8.44	28.2	6.66	1.83	1.78	28.2	6.66	1.83	1.78	1.17	1.000
¾	1¼	24.2	7.11	24.2	5.66	1.84	1.73	24.2	5.66	1.84	1.73	1.18	1.000
¾	1⅞	21.9	6.43	22.1	5.14	1.85	1.71	22.1	5.14	1.85	1.71	1.18	1.000
¾	1	19.8	5.75	19.9	4.61	1.86	1.68	19.9	4.61	1.86	1.68	1.18	1.000
¾	1⅞	17.2	5.06	17.7	4.08	1.87	1.66	17.7	4.08	1.87	1.66	1.19	1.000
¾	¾	14.9	4.36	15.4	3.53	1.88	1.64	15.4	3.53	1.88	1.64	1.19	1.000
¾	1⅞	12.4	3.85	13.0	2.97	1.89	1.62	13.0	2.97	1.89	1.62	1.20	1.000

University of Asia Pacific
Department of Civil Engineering
Mid Semester Examination Fall 2011
Program: B.Sc. Engineering (Civil)

Course Title: Environmental Engineering III Course Code: CE 431 Credit: 2.00
Time- 1 hour Full marks: 60

There are **THREE** questions. Answers any **TWO**. ($2 \times 30 = 60$)

1. (a) Describes with the diagram of recycling and resources recovery system in urban centers. (7)
 - (b) What is solid waste? Write down the factors upon which the composition of solid waste depends on? (1+5)
 - (c) What is capacity margin? A small city of 25,000 population of having 0.4 kg/cap/day municipal solid waste generation rate. Collection rate is 7 days per week. Find out the size of the storage container using the following equation: (2+5)

Size of storage container = $(N \times G \times F) / D + \text{capacity margin}$.

Where, N= no. of population (nos, cap)
G = average rate of waste generation(kg/ cap/ day)
F = weekly frequency of collection
D= density (kg/ m³) = 600 kg/ m³ (avg)
 - (d) Write down the general considerations to design of storage container. (10)
2. (a) Why method of sampling is very important? (3)
 - (b) Describe what kind of practices for source reduction are involved in Bangladesh (for dry recyclable materials , biodegradable materials and hazardous materials) and how the MSW are stored for collection by the external actors in each home and in what systems these wastes are collected before disposal and which department are usually responsible for the collection system specially in Dhaka city? (12)

- (c) Find out the effect of home recovery on energy content of collected solid wastes. (15)

Using the typical percentage distribution data given in the table below, estimate the energy of the remaining solid wastes if 80% of the cardboard, 80% of paper and 80% of yard wastes are recovered by the home owner, also analysis the effect of home recovery on energy content of collected solid waste if 80% paper is not recovered in the first situation.

Component	Weight (%)
Food waste	32.5
Paper (mixed)	35
News print	5
Cardboard	4
Rubber	0.5
Plastics	3
PVC	0.5
Leather shoe	0.5
Textiles	3
Yard waste	13
wood	3

3. (a) Differentiate between the hauled container system and stationary container system with necessary figures. (6)
- (b) Do an economic analysis of refuse collection and also give an economic decision about what size truck makes sense for the following job. (24)
- Solid wastes from Mirpur area to be collected using a stationary container collection system having 5 cubic meter containers. Suppose the annualized cost of purchasing , fueling and maintaining a compactor truck is given by the following expression:

$$\text{Annualized cost(\$/yr)} = \alpha + \beta V$$

Where, α and β are empirically determined which values are 25000 and 4000 respectively. V is the volume of truck in cubic yards.

The following conditions may be need for the analysis:

- Trucks require two person crews, with labor charged at 24\$ per hour (including benefits)
- The truck collects waste from 340 households each day.
- Each household generates 60lb of wastes per week.
- The trucks and crew work 5 days per week and alley pick up is provided once a week for each house.

- Container utilization factor = 0.70
- Average number of containers at each location = 1
- Collection - vehicle compaction ratio= 2.5
- Container unloading time= 0.15 h/ container
- Average drive time between container location= 0.15 h
- One way haul distance= 35 km
- Speed limit= 72 km/hr
- Time from garage to first container location= 0.25 h
- Time from garage to last container location= 0.35 h
- Number of trips to disposal site per day= 2
- Length of working day= 8h

$$(0.03704 \text{ cu yd} = 0.02832 \text{ m}^3)$$

The necessary tables are given below:

Table 2.10: Ultimate analysis of solid waste (per cent by weight in dry basis)

Component	Carbon (C)	Hydrogen (H)	Oxygen (O)	Nitrogen (N)	Sulphur (S)	Ash (A)
Food waste	49.1	6.6	37.6	1.7	0.2	4.8
Paper (mixed)	43.4	5.8	44.3	0.3	0.2	6.1
Newsprint	49.1	6.1	43.0	0.1	0.2	1.5
Cardboard	44.0	5.9	44.6	0.3	0.2	5.0
Rubber	77.8	10.4	-	-	2.0	9.8
Plastics	60.0	7.0	23.0	-	-	10.0
PVC	45.2	5.6	1.6	0.1	0.1	47.4
Leathershoes	42.0	5.3	22.8	6.0	1.0	22.9
Textiles	55.0	6.5	31.2	4.5	0.2	2.6
Yard waste	48.7	6.3	37.9	3.0	0.3	3.8
Wood	50.5	6.0	42.4	0.2	0.1	0.8

Source: adapted in part from Kaiser (1978)

Table 3.5: capacity margin of storage container.

Collection	Excess capacity required (%)		
	Individual	Communal	
		Attended	Unattended
Days per week			
6	66	66	100
7	33	33	50

Source: Habitat

Table 4.1: Typical values for haul constant coefficients m and n

Type of haul	Speed limit	m	n
	km/h	h/trip	h/km
Communal	88	0.016	0.011
Block	72	0.022	0.014
Kerbside	56	0.034	0.018
Door-to-door	40	0.050	0.025

Adapted from: Peavy et al., 1985

Table 4.2: Typical data for computing equipment and labour requirements for hauled- and stationary-container collection

Vehicle	Collection		Pick up loaded container and deposit empty containers, h/trip	Empty contents of loaded container, h/container	At-site time ϕ , h/trip
	Loading method	Compaction ratio, α			
Hauled container (Tilt-frame)	Mechanical	2.0-4.0	0.50		0.129
Stationary container (Compactor)	Mechanical	2.0-4.0		0.050	0.15

University of Asia Pacific
Department of Civil Engineering
Mid Semester Examination Fall 2011
Program: B.Sc. Engineering (Civil)

Course Code: CE 433
Time: 1.0 hour

Course Title: Environmental Engineering IV

Credit: 2.00
Full Marks: 100

[Assume reasonable value for missing data (if any)]

- (1) A sewage outfall discharges into a surface stream with a flow rate of $0.40 \text{ m}^3/\text{s}$, BOD_5 50 mg/l , DO 1.0 mg/l and temperature 24°C . The stream (upstream from the point of discharge) is found to have a flow rate of $1.25 \text{ m}^3/\text{s}$, BOD_5 1.5 mg/l , DO 6.0 mg/l , and temperature 24°C . Velocity of the mixture is 0.20 m/s and the average depth of stream is 2.60 m . Laboratory determined BOD rate constant of the mixture is 0.22 per day. Find the minimum value of dissolved oxygen (DO) and the distance downstream at which the DO is minimum. (Given: Saturation value of DO is given by: $\text{DO}_{\text{sat}} (\text{mg/l}) = 14.62 - 0.394T + 0.007714T^2 - 0.0000646T^3$; T in $^\circ\text{C}$) (34)
- (2) A lake with a surface area of $80 \times 10^6 \text{ m}^2$ is fed by a stream having an average flow rate of $16.0 \text{ m}^3/\text{s}$ and average total phosphorus concentration of 0.01 mg/L . It also receives treated wastewater from a sewage treatment plant at the rate of $0.30 \text{ m}^3/\text{s}$ having 4.9 mg/L phosphorus. The phosphorus settling rate in the lake is 12.0 m/year . (a) Estimate average phosphorus concentration in the lake, (b) Is phosphorus concentration in the lake sufficient to cause algal bloom? Explain. (22)
- (3) Answer ANY TWO of the following THREE questions: (9x2)
- (a) Mention the different categories of pesticides. What are the major groups of synthetic organic insecticides? Give one example from each group.
 - (b) Write down the different chemical forms in which inorganic Arsenic (As) could exist in water. In which chemical form(s) As is likely to present in groundwater of Bangladesh?
 - (c) The BOD_5 of a wastewater sample is 350 mg/L at 20°C . If $K=0.25/\text{day}$ at 20°C , calculate the BOD_5 at 25°C .
- (4) Answer ANY TWO of the following FOUR questions (13x2)
- (a) What do you understand by eutrophication? What are its adverse impacts? How eutrophication can be controlled?
 - (b) Explain the water quality problems related to high concentrations of ammonia and algae at Saidabad water treatment plant (SWTP).
 - (c) Explain how thermal pollution affects dissolved oxygen concentration of a water body.
 - (d) Which techniques/ methods are commonly used for removal of As from groundwater? Schematically (with simple sketches) show the mechanism of As removal from water by coagulation-adsorption-coprecipitation technique.

University of Asia Pacific
Department of Civil Engineering
Mid Semester Examination Fall 2011
Program: B.Sc. Engineering (Civil)

Course Title: Environmental Engineering III Course Code: CE 439 Credit: 2.00
Time- 1 hour Full marks: 60

There are **THREE** questions. Answers any **TWO**. ($2 \times 30 = 60$)

1. (a) Describe the objectives of EIA. (10)
(b) Describe the stages of project cycle? When does EIA starts in a project? (14+6)

2. (a) Who are the main actors in EIA? Describe briefly about them. (12)
(b) Why audit is so important in EIA? (4)
(c) Give an example of each category of project under Green, Orange A, Orange B and Red as per DoE classification. (4)
(d) Discuss screening procedure in EIA. (10)

3. (a) Why baseline studies are done in EIA? Write down minimum six obstacles to the implementation of EIA (7+3)
(b) You are involved in a project of selection of a road alignment in a rural area. (20)
The proposed road will be 20 km long. The rural area covered:

Agricultural land ----- 25%
Vegetation area ----- 15%
Residential area ----- 30%
Water bodies ----- 20%
Commercials & others ---- 10%

Write in brief the EIA of this project.

University of Asia Pacific
Department of Civil Engineering
Mid Semester Examination Spring 2011
Program: B. Sc. Engineering (Civil)

Course Title: Environmental Engineering VII
Time- 1 hour

Course Code: CE 439
Full marks: 20

1. a. Define DoE and their activities. (3)
- b. Read the background and description of the proposed project and fill up the screening format. Also give the full assessment or comments depending on the screening format. (17)

Background of the Project:

The Government of Bangladesh (GOB) looked for financial assistances from the World Bank to improve and rehabilitate the high priority rural infrastructure in 26 districts covering mainly the eastern parts of Bangladesh (excluding Chittagong hill tracts) under LGED. Responding GOB's request, World Bank agreed to extend its credit facilities of about US\$ 300 million for the Second Rural Transport Improvement Project (RTIP-2). The GOB contribution for the project will be US\$ 117 million.

It is expected that improvement of physical infrastructures will help to reduce the poverty by providing people and communities with opportunities to enhance productivity and access to innovations and more gainful marketing facilities. The participatory approach in selection, operation and maintenance of these facilities is expected to bring together various stakeholder groups, especially those who are socio-economically vulnerable into the decision making process and be benefited by the development.

The RTIP-2 bears potential risks on physical, biological, social and cultural environment in the project areas because of weak geology, rich biodiversity, high dependency of people on natural resources and widespread poverty, the social and environmental impacts are visibly significant, particularly when construction work is undertaken in rural areas.

Description of the Project:

The 14.25 km long Hatubhanga – kaliakoir- Fulbaria via Khatar Hat Upazila Road is one of the potential roads to be included in the road improvement subcomponent. The road is located in Mirzapur, District Tangail.

The road is constructed in 1985. Of the total 11km is earthen and rest 3.25km is bituminous paved road. Total average crest width of the existing road is only 3.05m which will be widened (about 3.75m) at both sides during construction. For widening the road, land (about 6.5 ha) is to be required to acquire. The road runs over almost plain agricultural land, canals and river. Only one bridge of span less than 15m will need to construct across a canal which goes dry during lean

season. The road is submerged during high floods such as 1987, 1988, 1998, 2000 & 2007. There are 8 culverts and bridges are located on the road.

The total population in this area is about 30,000. The people in the areas mostly depend on the agricultural land for living and also on fishing. There is also few bazars nearer to the location of roadside depending on good transportation facilities where people of this area are doing business and they have also shops in the bazars.

There is lot of trees like Gozari, Akasmoni, Eucapilptus, bamboo etc beside the roads. There are few mosques and religious schools which are located nearer the road alignment.

Student Name:

Registration No:

Note: Please attach the sheets below with the exam paper.

Rural Road Improvements

Name of Sub-project:

Location of Sub-project: 1). Upazila: 2). District:

Major Components of the Improvement works:

Screening Questions	Yes	No	Scale of Impact*			Remarks
			High	Medium	Low	
<p>Potential Environmental Impacts during planning and design phase/ Sub-project siting.</p> <p>Is the sub-project area adjacent to or within any of the following environmentally sensitive areas?</p> <ol style="list-style-type: none">1. Protected Area (Forest)2. Wetland (Beel, Haor), River3. National Park4. Wildlife sanctuary5. Buffer zone of protected areas6. Special area for protecting biodiversity						

Screening Questions	Yes	No	Scale of Impact*			Remarks
			High	Medium	Low	
<p>Potential Environmental Impacts from construction of improved road.</p> <p>Will the sub-project cause.....</p> <ol style="list-style-type: none"> 1. loss of agricultural land ? 2. negative effects on rare (vulnerable), threatened or endangered species of flora or their habitat ? 3. negative effects on designated wetlands ? 4. negative effects on wildlife habitat, populations, corridors or movement ? 5. negative effects on locally important or valued ecosystems or vegetations ? 6. destruction of trees and vegetation 7. impact on fish migration and navigation ? 8. obstruction of natural connection between river and wetlands inside project area ? 9. water logging in polder areas ? 10. insufficient drainage ? 11. negative effects on surface water quality? 12. negative effects on groundwater quality, quantity or movement? 13. loss of existing buildings, property, economic livelihood ? 14. increased soil erosion and/or sedimentation ? 						

Screening Questions	Yes	No	Scale of Impact*				Remarks
			High	Medium	Low	W	
15. negative impact on soil stability and compactness ?							
16. impacts on sustainability of associated construction waste disposal ?							
17. traffic disturbances due to construction material transport and wastes ?							
18. increased noise due to transportation of equipment and construction materials ?							
19. increased noise due to day-to-day construction activities ?							
20. increased wind-blown dust from material (e.g. fine aggregate) storage areas ?							
21. health risks to labors involve in activities ?							
<p>Potential Impacts of the improved road.</p> <p>Will the improved road cause</p> <ol style="list-style-type: none"> 1. negative effects on neighborhood or community characters ? 2. negative effects on local business, institutions or public facilities ? 3. potential social conflict between occupational groups-farmers vs. fisheries ? 4. degradation or disturbance of historical or culturally important sites (mosque, graveyards, monuments etc.) ? 5. blockage of navigation system ? 							

Screening Questions	Yes	No	Scale of Impact*			Remarks
			High	Medium	Low	

6. impediments to movements of people and animals ?
7. conflicts in water supply rights and related social conflicts ?
8. air quality ?

*Please consider scale of 1 -2 for Low, 2 -3 for Medium and 5 for High impact.

** Protected areas are lands and waters where development and use is restricted by legal or other means for the conservation of nature

Note: Please add any other screening questions relevant to the sub-project. Also provide additional comments and/or positive impacts in 'remarks' column.

Assessment:

Categorization:

Category	Action required	Assessment
Low impact		
Medium Impact		
High Impact		

Surveyed by:

Designation:

Signature:

Date:

The University of Asia Pacific
Department of Civil Engineering
Mid-Term Examination, Fall 2011

Course # CE 441
 Full Marks: 45 (15 x 3 = 45)

Course Title: Geotechnical Engineering II
 Time: 1 hour

Answer any **three (3)** of the following **four (4)** questions

1. (a) Mention the purposes of geotechnical subsurface exploration. Mention (names only) the steps/phases of a geotechnical subsurface exploration program. 8
- (b) What preliminary information should be available to a good geotechnical engineer to execute a subsurface exploration program for a multi-storey building project? 3
- (c) Mention four observations that should be noted by a good geotechnical engineer while visually inspecting the site as a part of reconnaissance phase of a subsurface exploration program. 4
2. (a) Mention (names only) the steps of field investigation phase of a geotechnical subsurface exploration program. Write down any three general guidelines used for selection of number and depth of boreholes. 7
- (b) Write down the names of any five (5) in-situ testing performed in the field under the field investigation phase of a sub-surface exploration (SSE) program. Which one is most commonly used and why? 2
- (c) Write short notes on (any two): 3 x 2=6
 - (i) Pressure meter test
 - (ii) Vane shear test
 - (iii) Cone penetration test
3. (a) The outside and inside diameters of a split spoon sampler are 2 inches and 1-3/8 inches, respectively. The outside and inside diameters of a Shelby tube sampler are 3 inches and 2-7/8 inches, respectively. Mention whether the samples are relatively disturbed or undisturbed. 3
- (b) Information obtained from a geotechnical site investigation is summarized below. Determine cohesion and angle of internal friction at corresponding depths of the clay and sand deposits, respectively, based on the available data (use empirical correlations as provided in Appendix). Use hammer efficiency as 45%. 12

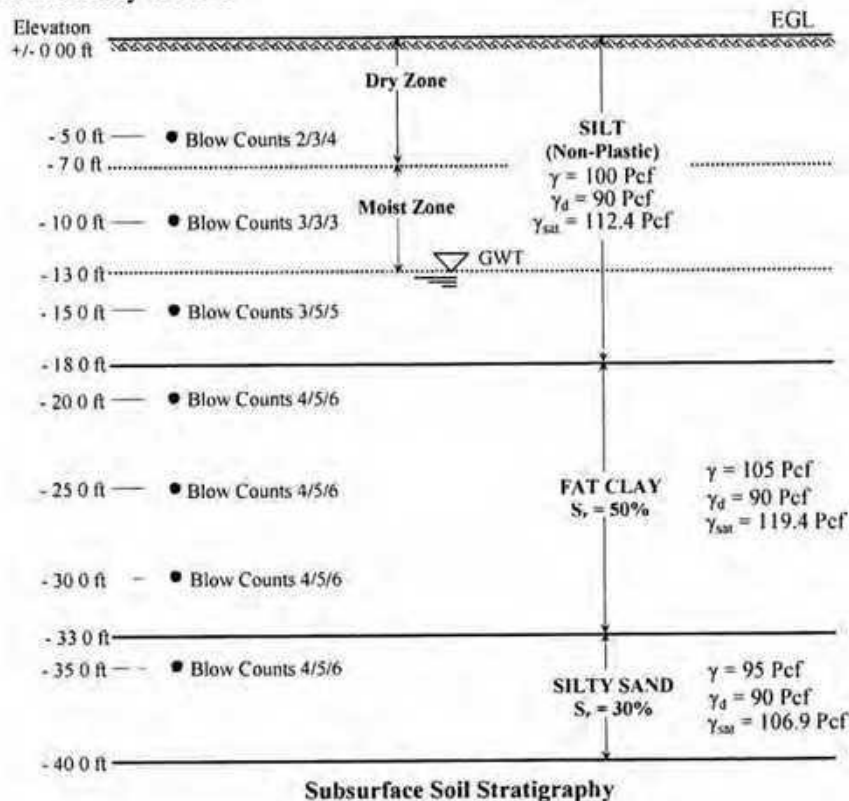

4. (a) Discuss, in brief, shallow and deep foundations. Categorize shallow foundation. 6
- (b) Sketch with very brief description the shear failure mechanisms of shallow foundation system for various types of soils. 9

APPENDIX
Parameter for 60% Energy Correction For Field SPT

E_m = Hammer Efficiency (Donut + Cathed)	= 0.55 to 0.60
C_B = Correction for Borehole Diameter	= 1.0 (For Dia 2.5" – 4.5") = 1.05 (For Dia of 6") = 1.15 (For Dia 8")
C_S = Correction for Sampler	= 1.0 Standard Sampler = 1.2 Sampler Without Liner
C_R = Correction for Rod Length	= 0.75 for L = (3-4) m = 0.85 for L = (4-6) m = 0.95 for L = (6-10) m = 1.0 for L > 10 m

Relevant Empirical Correlations

$$CF_1 = \sqrt{\frac{2000}{\sigma_{v0}'}} \quad (\sigma_{v0}' \text{ in psf})$$

$$C_u = (q_{unc}/2)$$

$$q_{unc} = 250 N$$

$$\phi' = 17 + \sqrt{20(N_1)_{60}}$$

The University of Asia Pacific
Department of Civil Engineering
Mid-Term Examination Fall 2011
Program: B.Sc. Engineering (Civil)

Course Title: Transportation Engineering II
(Highway Design & Railways)

Course Code: CE 451

Credit: 3.00

Time : 1 hr

Full Marks: 60

There are **FOUR** questions in this section. Answer any **THREE**.

1. (a) What is gauge? Why is it desirable to use uniform gauges in a country? (2+6)
- (b) Why generally the followings are favored? (6)
(i) Flat footed rail (ii) Broken stone (iii) Elastic fastening
- (c) Find out the length of the transition curve for a M.G curve of three degrees, having a cant of 10 cm. The maximum permissible speed on the curve is 80 km p.h. (6)

2. (a) Draw a typical layout of a right hand turnout. (5)
- (b) Calculate the maximum permissible train load that can be pulled by a locomotive with 5 pairs of driving wheels having an axle load of 20 tons each on a straight level B.G. track at a speed of 65 kmph. Also calculate the reduction in speed if the train has to run on a rising gradient of 1 in 200. What would be the further reduction in speed if the train has to negotiate a 3° curve on the rising gradient? Assume coefficient of friction as 0.2. (10)
- (c) What are the different procedure for finding respective speeds on main and branch lines? (5)
Highway Design & Railways

3. (a) Briefly list the important requirements of ideal (9)
(i) Rail
(ii) good spike
(iii) Ballast
- (b) What is the significance of double yellow signal? (5)
- (c) Write a short note on Vacuum brakes (6)

4. (a) Describe the classification of station according to function. (7)
- (b) Why is it necessary to provide the followings (9)
(i) Geo-textile (ii) Tilting of rail (iii) Coning of wheel
- (c) Establish a relationship between degree of curvature and versine of curve. (4)

University of Asia Pacific
Department of Civil Engineering
Mid Semester Examination Fall 2011

Course # CE 461

Course Title: Irrigation and Flood Control

Time: 1 hour

Total Marks: 60

Section A

Answer all questions

1. Define the following (any two) (2×2 = 4)
 - a. Water distribution efficiency
 - b. Net Irrigation Requirement
 - c. Soil-moisture-Irrigation relationship
2. Sketch the typical layout of a canal system. What are the different ways in which the irrigation canals can be aligned? (4+2)
3. Derive the relationship between discharge through the irrigation system, the average depth of water, the rate of infiltration, the area of the land irrigated and the approximate time required to cover given area with irrigation. Also find the maximum area that can be irrigated with the supply. (5)
4. Sketch a typical cross section of an irrigation canal. What are the purposes of having berms in an irrigation canal? (2+3)
5. What are the advantages of canal lining and how to find its economic viability? (3+5)
6. After how many days will you supply water to soil in order to ensure sufficient irrigation of the given crop, if, (6)
 - Field capacity of the soil = 27%
 - Permanent wilting point = 12%
 - Dry density of soil = 1.3 gm/cc
 - Effective depth of root zone = 7.5 cm
 - Daily consumptive use of water for the given crop = 10 mm.
7. An irrigation canal has gross commanded area of 80,000 hectares out of which 85% is cultivable irrigable. The intensity of irrigation for Kharif season is 30% the Duty at its head is 800 hectares/cumecs for Kharif season and 1700 hectares/cumec for Rabi season. Find the discharge required at the head of the watercourse (6)

Section B

Answer Question no.1 and any ONE from the rest

1. (a) Define Flood. What are causes of flood? (3+3)
(b) Write short note on types of flood. (6)
2. Explain the following (any four) (3×2 = 6)
 - i) Return Period
 - ii) Flood Plain
 - iii) Bankful Stage
 - iv) Design Flood
 - v) Flood and the poor
3. Explain impacts of flood. (8)

The University of Asia Pacific
Department of Civil Engineering
Mid Term Examination Fall 2011

Course: CHEM 111

Full Marks: 40

Course Title: Chemistry

Time: 1 Hours

Answer any **Four** questions:

1. (a) What is band spectra ? (2)
(b) Sketch the atomic spectra of hydrogen. (4)
(c) Uranium has atomic number 92 and atomic weight 238.029. Find its number of electron, proton and neutron. (4)
2. (a) State Pauli Exclusion principle. (2)
(b) Write the electronic configurations of the O^{16} atom and the P^{-3} ion. (4)
(c) Draw the three dimensional shapes of s- and p-orbitals. (4)
3. (a) What is meant by 'covalent bond' ? (2)
(b) Show that the bonds in F_2 and HF are covalent in nature. (4)
(c) What is co-ordination bond? Show that $POCl_3$ has one co-ordination bond. (4)
4. (a) What is 'bond order' ? (2)
(b) Draw the molecular orbital of H_2 and thus predict the bond order and magnetic property of H_2 molecule. (4)
(c) What is 'sp² hybrid bond' ? Explain sp² hybridization in BF_3 molecule. (4)
5. (a) Define 'antibonding and non-bonding' electron. (2)
(b) Draw a molecular orbital and indicate the σ and σ^* molecular orbitals. (4)
(c) Explain that ionic bonds have high dielectric constant. (4)

The University of Asia Pacific
Department of Civil Engineering
Mid Term Examination Fall - 2011
Program: B. Sc Engineering (2nd Year/ 1st Semester)

Course Title: Basic Electrical Engineering
 Time: 1.00 Hour

Course No. ECE 201

Credit Hours: 3.00
 Full Marks: 60

[There are **four** questions. Answer any **three**. Figures in the right margin indicate marks]

1. a. State the following laws: [8]
- (i) Ohm's Law
 - (ii) Kirchhoff's Voltage Law (KVL)
 - (iii) Kirchhoff's Current Law (KCL)

- b. Using KVL find V_1 , V_2 and V_{ab} . [12]

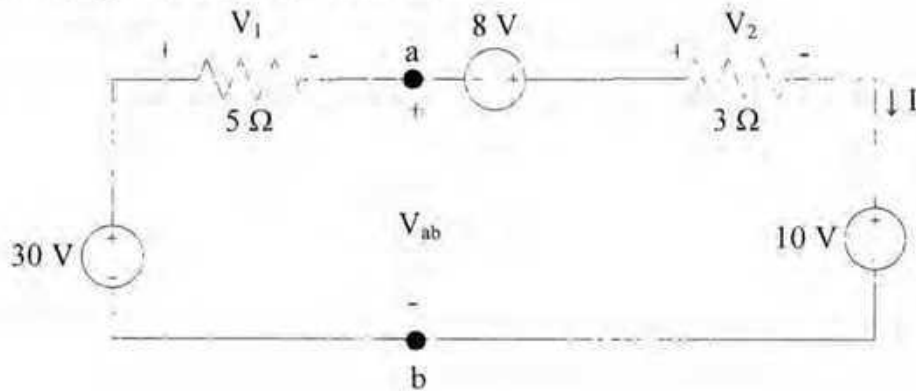

2. a. What do you understand by short and open circuit conditions? [6]
- b. Using series/parallel combination find the equivalent resistance as indicated in the figure [14]

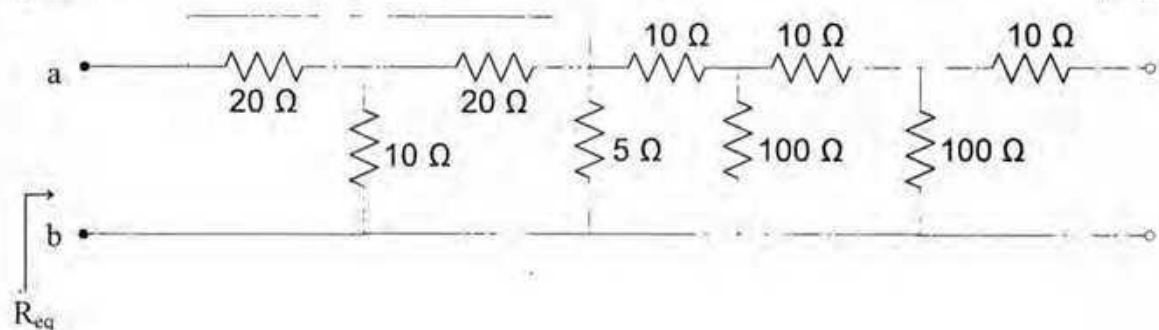

3. a. Show that for the following circuit, $i_1 = \frac{R_2}{R_1 + R_2} \cdot i$ and $i_2 = \frac{R_1}{R_1 + R_2} \cdot i$ [10]

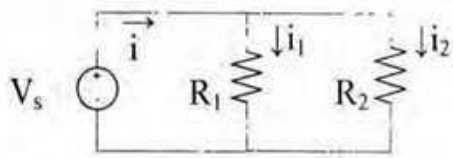

- b. Using voltage divider rule calculate V_o in the circuit. Also calculate the current ' i ' shown in the figure. [10]

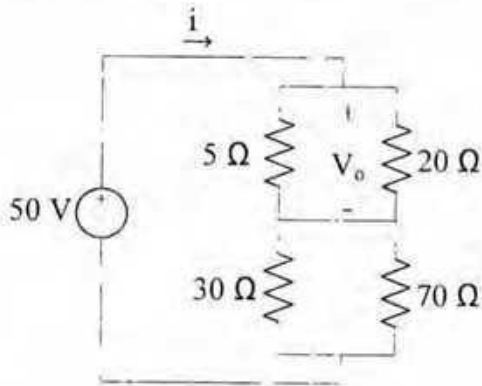

4. a. Using node voltage analysis calculate V_o . [10]

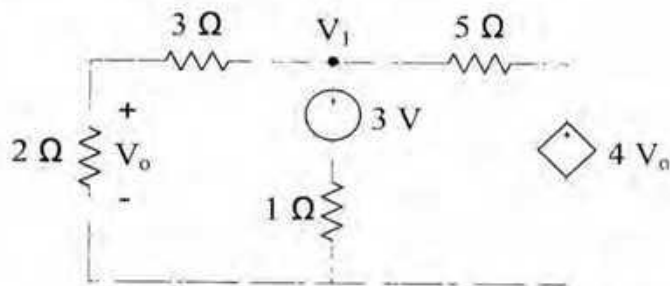

- b. Calculate V_o using either node voltage analysis or mesh current analysis. [10]

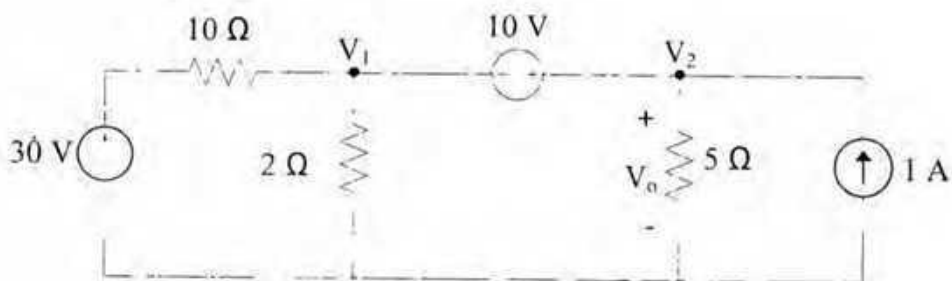

University of Asia Pacific
Dept. of Civil Engineering
Midterm Examination
Fall Semester, 2011

Course Title: Principles of Economics
Time: 1.00 Hour

Course Code: ECN-201

Credit: 2
Full Marks: 20

Answer any TWO of the following Questions (No. 1 - 4)

Marks: 10 x 2 = 20

1. a) What do you understand by the term 'trade-offs'? *[3+7]*
b) How does the concept of 'trade-offs' related with the concept of 'cost' in economics?
Discuss in relation to the production possibility curve.

2. a) What are the major 'economic activities'? *[3+7]*
b) How does the 'market' organize economic activities?
Explain the concept of market with the model known as circular flow of economic activities.

3. a) Can everyone be gainer from trading? *[3+7]*
b) Explain the idea of absolute advantage and comparative advantage with examples.

4. What is the cause of 'inflation'? Why is it too hard to deal with the problem of inflation? *[10]*
Explain in light of Phillip's curve.

University of Asia Pacific
Department of Architecture/ Business Admin/ CE/ CSE/ EEE
Mid Term Examination: Fall 2011
Program: B Arch/ BBA/ B.Sc Engineering

Course No.: HSS 101
Time- 1.00 hour

Course Title: English Language I

Credit: 3.00
Total Marks: 20

Name of the student:..... Registration no:.....

Department:..... Invigilator's Signature:.....

Write all answers on the question paper

Q.1. The following extract is about *the National Flag of Bangladesh*. Read and complete the questions. 2.5

The national flag of Bangladesh is bottle green in colour and rectangular in size with the length to width ratio of 10:6. It bears a red circle on the background of green. The colour in the background represents the greenery of Bangladesh while the red circle symbolizes the rising sun and the sacrifice of lives in our liberation war. The flag was designed by Kamrul Hasan. At first it had a different look. There was a golden coloured map of Bangladesh at the centre of the red circle which was the original design of the flag of Bangladesh under which the valiant freedom fighters fought during the liberation war. The national flag was first hoisted on the 3rd of March 1971 by A S M Abdur Rub at the historic 'Bat tala' in Dhaka University campus. The flag of Bangladesh was first hoisted in the UN, September 1974 and appeared later in the UN's stamp series 'Flag of the Member State'.

- a. How _____?
- b. _____ the red circle _____?
- c. Who _____ the flag?
- d. _____ first hoisted?
- e. When _____ in the UN?

Q.2. Complete the following sentences with negatives. (Any three) 3

- a. The Pyramids _____ the Chinese.
- b. I _____ the tutorial as I was too weak to read.
- c. Oil and water _____ with each other.
- d. Rickshaw _____ a dangerous vehicle.
- e. Rafique is allergic to dust. He _____ without a mask.

Q.3. Complete the following passage using appropriate forms of Pronouns (any five) 2.5
Teresa is moving to ----- new flat tomorrow. ----- will share the flat with her friend Linda.

Linda: I'll put all of your DVD s in this bag and ----- can stay in that box.

Teresa: Is that violin -----?

Linda: No. I don't think it's ----- . Because it's got ----- name on it.
Teresa: Ok. I'm hungry. Let's help ----- to sandwiches. won't we?

Q.4. Complete the following sentences using *a lot of, any, a few, some, etc.* 2.5

On Saturday I went to the fair with my friend Sarah. I wanted to buy ----- chocolate chip cookies but there weren't ----- left for me. I had to have ----- Fruit cakes. We saw ----- creatures of different colour & ----- of them were very large.

Q.5. Put in the missing *a/ an, the* where necessary in the passage. 2.5

Do you see man standing near door? He works as assistant in same shop as I do. Well I saw him the other day and he was driving big red Porsche. And do you see expensive clothes he's wearing? Where does he get money to pay for it all? A month ago he hadn't got penny. He wasn't worthy person too. He's got change in life.

Q.6. Write a biography of Muhammad Zafar Iqbal, a famous science fiction writer of Bangladesh, from the information below 7

Name: Muhammad Zafar Iqbal

Place of Birth: Sylhet

Date of Birth: 23rd December, 1952

Education:

1968: Passed SSC from Bogra Zilla School.

1970: Passed HSC from Dhaka College

5th May 1971: His father Foyzur Rahman Ahmed, a police officer, was captured and killed by Pakistani Army in front of his eyes.

1976: Completed BSc in Physics from Dhaka University and his first ever science fiction Kopotronik Sukh Dukkho (Kopotronic Joy and Sorrow) was published

1982: Earned his PhD degree from University of Washington

Achievements:

1983-1988: Worked as a post-doctoral researcher at California Institute of Technology.

1988: Joined Bell Communications Research, now known as Telcordia Technologies, as a Research Scientist

1994: Joined the faculty of the Department of the Computer Science and Engineering of Shahjalal University of Science and Technology

Works:

2002: Wrote Neuron e Omuronon (Resonance in Neuron) with Mohammad Kaykobad

2011: A film named Amar Bondhu Rashed (Rashed, My Friend) was directed by Morshedul Islam which is an adaptation of his novel under the same title

University of Asia Pacific
Department of Architecture/ Business Admin/ CE/ CSE
Mid-term Examination: Spring 2011
Program: B Arch/ BBA/ B. Sc Engineering

Course Title: English Language II
Time: 1.00 Hour

Course Code: HSS 103

Credit: 3.00
Full Mark: 20

Name of the Student:..... Registration No:.....

Invigilator's Signature:..... Examiner's Signature:..... Marks obtained:.....

1. Rewrite any six (06) of the following sentences correctly: 03

a) His knowledge in all the topics are praiseworthy.

Ans:

b) The Philippines are in Asia.

Ans:

c) My trousers needs cleaning.

Ans:

d) One of the letters were addressed to the chairman.

Ans:

d) Fifty thousand taka seem a lot of money.

Ans:

f) Hasan together with his friends are going to the picnic.

Ans:

g) Each of the books have been appreciated.

Ans:

h) I, you and Mahmud worked together for the assignment.

Ans:

2. Change the forms of voice of any six (06) of the following sentences: 03

a) The student will finish the task by tomorrow.

Ans:

b) Do not leave the room until he permits.

Ans:

c) The product will be launched by the company next year.

Ans:

d) He did not object to any of my points.

Ans:

e) Who brought the book here?

Ans:

f) Which assignment do you prefer?

Ans:

g) Alas! We could not win the match.

Ans:

Ans:

h) They said nothing on the issue.

Ans:

3. Complete any four (04) of the following sentences using correct conditional structures: 02

a) If you call me,

b) if you did it.

c) If I lost my money,

d), my brother would come.

e) If he had been invited,

f) if he did not understand his fault.

4. Change the forms of speeches of any six (06) of the following sentences: 03

a) My brother said to me. "Did you go to university yesterday?"

Ans:

b) He said to me, "I tried my best but I could not win."

Ans:

c) He told us that he would meet us soon.

Ans:

d) The teacher said to the students, "Listen to me carefully."

Ans:

e) He said to me, "Let us discuss in more detail."

Ans:

f) He said to me, "Shall I bring you the book?"

Ans:

g) He said, "What a horrible scene that was!"

Ans:

h) "Hurry up, my boys," said their teacher.

Ans:

5. Make sentences with any two (02) of the following pairs of words: 02

a) Later:.....

After :.....

b) Well :.....

Good :.....

c) Addicted to:.....

Devoted to:.....

6. Write one synonym and one antonym of any two (02) of the following words and make sentences with those synonyms and antonyms: 04

a) Brutal:

Synonym:..... Sentence:

Antonym:..... Sentence:

b) Conceal:

Synonym:..... Sentence:

Antonym:..... Sentence:

c) Optimistic:

Synonym:..... Sentence:

Antonym:..... Sentence:

7. Make sentences with any six (06) of the following phrases: 03

a) Wet blanket:

b) By heart:

c) Give a hand:

d) In the soup:

e) Never mind:

f) Red-handed:

g) Green with envy:

h) White collar worker:

University of Asia Pacific
Department of Interdepartmental Courses
Mid Semester Examination Fall 2011
Programmes: BArch, BBA, BSc Engineering (CE, CSE, EEE)

Course Title: Bangladesh Studies: Society and Culture **Course Code: HSS 111(a)**
Credit: 2.00 **HSS 211(a) [for CE]**

Time: 1 Hour **Full Marks: 40**

There are two sections in the question paper namely "SECTION A" and "SECTION B". You have to answer from both sections according to the instruction mentioned in each section.

SECTION A

There are **FOUR** questions in this section. Answer **ANY THREE** (3x10)

1. Discuss the characteristics of sociology following Robert Bierstedt.
2. Define social survey. What are the steps that are followed to conduct the survey?
3. Why anthropological method is suitable to study the society and culture of Bangladesh. Highlight its characteristics.
4. What is social stratification? Discuss on class and caste.

SECTION B

There are **THREE** topics in this section. Write short notes on **ANY TWO** (2x5)

5. Historical method and case study method.
6. Two specialized fields of sociology.
7. Functional pre-requisites of a society (Social Structure)

University of Asia Pacific
Department of Interdepartmental Courses
Mid Semester Examination, Fall 2011
Programmes: BBA, BSc Engineering (CE, CSE, EEE)

Course Title: Bangladesh Studies: History
Credit: 2.00

Course Code: HSS 111(b)
HSS 211(b) [for CE]

Time: 1 Hour

Full Marks: 40

There are **FIVE** questions. Answer **ANY FOUR** (4x10)

1. What were the *janapadas*? Identify the present location of the different *janapadas* of ancient Bengal.
2. Who was Shansanka? Why is he celebrated in the history of ancient Bengal?
3. What do you mean by the term *Matsyanyam*? Discuss when & how was it ended with reference to its sources.
4. What was the main achievement of Bakhtiyar Khilji? Write about two major impacts brought in Bengal with the arrival of Islam.
5. Discuss Alauddin Hussain Shah's social and cultural contributions in Medieval Bengal.

The University of Asia Pacific
Department of Civil Engineering
Mid-Term Examination, Fall-2011

Course # IMG 301

Credit: 2.0

Course Title: Principles of Management

Full Marks- 40

Time: 60 minutes

Answer any 3 (three) of the following questions. All questions are of equal value.

01. How would you define "Management"? "All managers carry out managerial functions, but the time spent for each function may differ"-explain. Why you need to study management as a student of civil engineering department?
02. What are the management functions? How do the required managerial skills differ in the organizational hierarchy? What are the differences between productivity, effectiveness and efficiency?
03. Why has Frederick Taylor been called "The father of scientific management" and Henri Fayol "The father of modern management theory"? Discuss.
04. What is meant by the term "Management theory Jungle"? Discuss the Managerial Roles Approach & Mckinsey's 7-S framework for management analysis.
05. State the internal and external environment in which managers operate. What are the major social responsibilities of business managers? Discuss.
06. Define and explain planning? Briefly state the nature of planning. Discuss the steps in planning.

UNIVERSITY OF ASIA PACIFIC
Department of Basic Sciences and Humanities
Mid Semester Examination Fall 2011
Program: B.Sc. Engineering (Civil)

Course Title: Mathematics I
 Time: 1.00 Hr.

Course Code: MTH 101

Credit: 3.00
 Full Marks: 60

N.B.: Answer any 4 (FOUR) questions. Figures in the right margin indicate the marks of the respective questions.

Q1.	(a) Define function and injective function with examples. (b) Define domain and range of a function $f(x)$. Sketch and determine the domain and range of the function $f(x) = x - 2 + x - 4 $	6 9
Q2.	(a) Define continuity of a function $f(x)$ at a point $x = c$. Test the continuity of $f(x)$ at $x = 1$, where $f(x) = \begin{cases} x^2 + 2, & x \leq 1 \\ x + 2, & x > 1. \end{cases}$ (b) Define $\delta - \varepsilon$ definition of continuity of $f(x)$ at $x = a$. Prove that $\lim_{x \rightarrow 3} 4x - 5 = 7$	8 7
Q3.	(a) Define continuity from the left and continuity from the right. Test the Continuity of $f(x) = \sqrt{1 - x^2}$ on $[-1, 1]$. (b) Can a function with no limit be continuous? Discuss.	10 5
Q4.	(a) Test the differentiability of $f(x)$ at $x = 1$, where, $f(x) = x + x - 1 $. (b) Define tangent line and secant line. Differentiate $f(x) = \cos x$ by the fundamental rule.	10 5
Q5.	(a) Use Chain rule to find the differential coefficients of the functions $y = e^{\sin x} \cdot \sin a^x$ with respect to x . (b) Oil spilled from a ruptured tanker spreads in a circle whose radius increases at a rate of 0.56 m/sec. How fast will the area of the circle increase when the radius is 1.69 square meter?	7 8

University of Asia Pacific
Department of Basic Sciences & Humanities
Mid-Semester Examination, Fall 2011
Program: B.Sc. Engineering (Civil)

Course No.: **MTH 103** (Credits: 3)
Full Marks: **60**

Course Title: **Mathematics II**
Time: **One hour**

Answer any **FOUR** questions.

1. (a) Prove that the general equation of the first degree in x, y, z that is
 $ax + by + cz + d = 0$ represents a plane. 8
- (b) Find the equation of the plane passing through the points $(2, 1, 3)$, $(3, -2, 4)$
and $(-1, 2, 0)$. 7
2. (a) Define with example of plane. 5
- (b) Find the equation of the plane passing through the point $(1, 1, 2)$ and perpendicular
to each of the planes $2x - 2y - 4z - 6 = 0$ and $3x + y + 6z - 4 = 0$. 10
3. Find the distance of a point (x_1, y_1, z_1) from a given line whose direction cosine
are l, m, n . 15
4. (a) Find the shortest distance between two given lines whose direction cosines
are l_1, m_1, n_1 and l_2, m_2, n_2 . 10
- (b) Find the coordinates of the intersection of line $\frac{x+1}{1} = \frac{y-5}{-2} = \frac{z+2}{4}$ with the
plane $4x + 3y - 5z = 6$. 5
5. (a) Find the plane passing through the intersection of $x + 2y - 3z + 1 = 0$ and
 $2x - y + z + 2 = 0$ and perpendicular to the line $\frac{x-1}{1} = \frac{y+2}{-2} = \frac{z+1}{3}$. 8
- (b) Find the angle between the line $\frac{x+1}{3} = \frac{y-1}{6} = \frac{z-2}{-6}$ and the plane
 $2x - 2y + z - 3 = 0$. 7

University of Asia Pacific
Department of Basic Sciences & Humanities
Mid-Semester Examination, Fall 2011
Program: B.Sc. Engineering (Civil)

Course No.: MTH 203 (Credits: 3)
 Full Marks: 60

Course Title: **Mathematics IV**
 Time: **One hour**

Answer any FOUR questions.

1. (a) Define order and degree of a differential equation. 6
 Obtain the differential equation of the family of curves $xy = c(c^3x - 1)$, c being a constant. Hence write its order and degree.
- (b) Solve the logistic equation $\frac{dP}{dt} = P(a - bP)$, $P(0) = P_0$. 9
2. Find the orthogonal trajectories of the family of circles with centers on the line $y = -x$ and passing through the origin. Sketch several members of these. 15
3. (a) When $M(x, y)dx + N(x, y)dy = 0$ said to be exact? Solve the differential equation $(x^2 + y^2 + 1)dx - 2xydy = 0$. 9
- (b) Suppose a student carrying a flu virus returns to an isolated university campus of 1000 students. If it is assumed that the rate at which the virus spreads is proportional not only to the number P of infected students but also to the number of students not infected, determine the number of infected students after 10 days if it is further observed that after 5 days 45 students are infected. 6
4. Evaluate the followings: 6
 - (i) $L\{t^n\}$ by definition 6
 - (ii) $L\left\{\frac{\sin at}{t}\right\}$ and (iii) $L\{t \sinh 2t\}$ by using properties. 3
5. State Final Value Theorem. Verify this theorem for $F(t) = \frac{3}{5}e^{-5t}$. Find the Laplace transform of cosine integral $Ci(t) = \int_t^\infty \frac{\cos u}{u} du$. 15

December 12, 2011

University of Asia Pacific
Department of Basic Sciences and Humanities
Mid Semester Examination Fall- 2011
Program: B.Sc Engineering (Civil)

Course Title: Physics I
 Time: 1.00 Hour

Course Code: PHY-101

Credit: 3.00
 Full Mark: 60

[N.B- The figures in the margin indicate full marks. There are FIVE questions. Answer any FOUR]

1. (a) State and explain the first law of thermodynamics. 10
- (b) When a system is taken from the state A to state B along the path ACB , 80 joules of heat flows into the system and the system does 30 joules of work (fig. below).
- (i) How much heat flows into the system along the path ADB , if the work done is 10 joules?
- (ii) The system is returned from the state B to the state A along the curved path. The work done on the system is 20 joules. Does the system absorb or liberate heat and how much?
- (iii) If $U_A = 0$, $U_B = 40$ joules, find the heat absorbed in the process AD and DB . 5

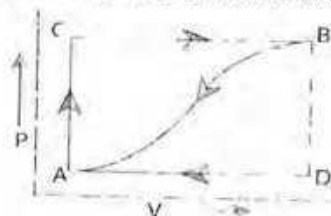

2. (a) Show that Work done during an adiabatic process is $W = \frac{1}{1-\gamma} [RT_2 - RT_1]$ 10
- (b) A motor car tyre has a pressure of 2 atmospheres at room temperature of 27°C . If the tyre suddenly bursts, find the resulting temperature. 5
3. (a) State the equipartition theorem. Show that the average kinetic energy associated with each degree of freedom $= \frac{1}{2} kT$. 10
- (b) At what Celsius temperature will oxygen molecules have the same root mean square velocity as that of hydrogen molecules at -100°C ? 5
4. (a) Show that the slope of an adiabatic curve is γ times steeper than that of the isothermal curve at a point where the curves intersect each other. 10
- (b) A quantity of air at 27°C and normal atmospheric pressure is suddenly compressed to half its original volume. Find the final pressure and temperature. 5
5. Describe the condition for the formation of Newton's ring by reflected light and show that in this case the centre is always dark. 15