

University of Asia Pacific
Department of Civil Engineering
Final Examination, Fall 2014
Program: B.Sc. Engineering (Civil)

Course Title: Introduction to Civil & Environmental Engineering
Time: 2.0 hours

Course Number: CE 107
Full Marks: 100

PART- I

Question No. seven is compulsory. Answer any other four questions:

1. (a) Discuss, in brief, science, engineering and technology. (8)
2. (a) Define civil engineering according to ASCE and write a brief history. (8)
3. (a) Mention some (minimum six) of the important roles of civil engineers in the development of infrastructure. (4)
(b) Mention few names of infrastructures that civil engineers are generally involved in development. (4)
4. (a) What are the major sub-disciplines of civil engineering? Mention some other sub-disciplines that are always inevitably participatory in any civil engineering project. (3)
(b) Give the names in details of the following codes with their related fields. (2)
(i) BNBC (ii) ASTM (iii) ACI (iv) AASHT
(c) Categorize building based on type of occupancy. (3)
5. (a) Categorize construction materials based on specific property of material. What are the major factors for choice of materials? (2)
(b) Mention (names only) few types of loads to be considered in design. (2)
(c) Mention (names only) major components of a building. (4)
6. (a) Classify (mention categories only) surveying according to different criteria (4)
(b) What is project surveying? Write down the common features to be considered under reconnaissance phase of a project surveying of a highway project. (1.5 + 2.5)
7. A Six-storied residential building is to be constructed. Estimate the total construction cost as per the following particulars and specifications of the building. Use PWD schedule and other relevant information provided in the attached appendix. (18)

Sl No	Particulars	Specification
01	Land Size	25m x 35m
02	Building type	Residential (Standard)
03	Allowable Bearing Capacity (q_u)	3 ksf
04	Floor Level	Six
05	Plinth Area	350 Square meter
06	Construction Material	19-21 MPa, RCC Structure 1:1.5:3 (Brick Chips)
07	Ground Floor	Car Parking

Sl No	Particulars	Specification
08	Roof top RCC water tank including beams and	2500 Gallons
09	Structure type	RCC Frame Structure
10	Underground water reservoir, distribution line, water pump, pump house, WASA charge	7000 gallons
11	Boundary wall	RCC frame

PART- II

Answer any five questions:

8. (a) What is renewable energy? Why do we call it as clean energy? (3)
 (b) Name the water parameters, which should be examined for maintaining drinking water quality. (0.5x6=3)
 (c) How can we reduce population growth of a specific area? (4)
9. (a) What is air pollution? Write down the name of air pollutants. (1+2=3)
 (b) Define: Age Structure, Biomass, Autotrophs (3x1=3)
 (c) Write down the factors that trend to increase biodiversity. (4)
10. (a) Write down the causes of acid rain due to reactions in the environment. (4)
 (b) What are the advantages of installing wind turbine at coastal regions? Explain. (4)
 (c) What is a catchment area? (2)
11. (a) Define: Water Footprint, Water Conservation (2x1.5=3)
 (b) Write down the comparisons between biotic and abiotic? (3)
 (c) What is a burner reactor? What are the main components of a burner reactor? (4)
12. (a) Name the major sectors of EPA Green Engineering Program. (2)
 (b) What are the main requirements of a fusion process? (3)
 (c) Write down the potential solutions of acid rain. (5)
13. (a) Define: Human Demography, Life Expectancy (2x1=2)
 (b) Describe the major kinds of air pollution sources. (5)
 (c) Write down the comparisons between wind power plant and tidal power plant. (3)
14. (a) Define: Nuclear Energy, Biodiversity (2x1=2)
 (b) Briefly demonstrate the components of ecosystem. (4)
 (c) Explain the relation of water head with power generate rate in a hydroelectric plant. (4)

University of Asia Pacific
Department of Civil Engineering
Final Examination Fall 2014
Program BSC Engineering (Civil)

Course Code: HSS101

Course Title: English Language I

Time: 3Hours

Full Marks: 50

1. Read the passage and answer the questions that follow:

2x5=10

Animal Farm is an allegorical and dystopian novella by George Orwell, first published in England on 17 August 1945. According to Orwell, the book reflects events leading up to the Russian Revolution of 1917 and then on into the Stalin era in the Soviet Union. Orwell, a democratic socialist, was a critic of Joseph Stalin and hostile to Moscow-directed Stalinism, an attitude that was critically shaped by his experiences during the Spanish Civil War. The Soviet Union, he believed, had become a brutal dictatorship, built upon a cult of personality and enforced by a reign of terror. In a letter to Yvonne Davet, Orwell described *Animal Farm* as a satirical tale against Stalin ("*un conte satirique contre Staline*"), and in his essay "Why I Write" (1946), he wrote that *Animal Farm* was the first book in which he had tried, with full consciousness of what he was doing, "to fuse political purpose and artistic purpose into one whole".

The original title was *Animal Farm: A Fairy Story*, though the subtitle was dropped by U.S. publishers for its 1946 publication and subsequently all but one of the translations during Orwell's lifetime omitted it. Other variations in the title include: *A Satire* and *A Contemporary Satire*. Orwell suggested the title *Union des républiques socialistes animales* for the French translation, which abbreviates to URSA, the Latin for "bear", a symbol of Russia, and which recalled the French name of the Soviet Union, *Union des républiques socialistes soviétiques*.

Orwell wrote the book from November 1943 to February 1944, when the wartime alliance with the Soviet Union was at its height and Stalin was regarded highly by the British people and intelligentsia, a circumstance that Orwell hated. It was initially rejected by a number of British and American publishers, including one of Orwell's own, Victor Gollancz. Its publication was thus delayed, though it became a great commercial success when it did finally appear partly because the Cold War so quickly followed World War II.

Time magazine chose the book as one of the 100 best English-language novels (1923 to 2005); it also featured at number 31 on the Modern Library List of Best 20th-Century Novels. It won a Retrospective Hugo Award in 1996, and is also included in the Great Books of the Western World selection.

- What is *Animal Farm* and what does it reflect?
- What are the various other titles of *Animal Farm*?
- Who was Orwell and what did he observe about the Soviet Union?
- What is "Victor Gollancz"?
- Do you think *Animal Farm* is famous? What according to the passage says so?

2. Translate the following text to English:

4

নোয়াখালী জেলার হাতিয়া উপজেলার ছোট্ট একটি দ্বীপ, নিঝুম দ্বীপ। নানান বৈচিত্র্যে ভরপুর এই দ্বীপ এখন বাংলাদেশের অন্যতম ভ্রমণ কেন্দ্র। এখানকার জাতীয় উদ্যানে আছে অসংখ্য চিত্রা হরিণ। নিঝুম দ্বীপের মতো দেশের অন্য কোন বনে কাছাকাছি থেকে এত বেশি চিত্রা হরিণ দেখা যায় না। শীতে নানান রকম অতিথী পাখি এই দ্বীপে বেড়াতে আসে। দ্বীপে পর্যটকদের খাওয়ার ভালো ব্যবস্থাও আছে। এই শীতে তাই ঘুরে আসতে পারেন সুন্দর এই দ্বীপ থেকে। নোয়াখালী জেলার দক্ষিণাংশে, হাতিয়া উপজেলায় বঙ্গোপসাগরের মোহনায় জেগে ওঠা ছোট্ট দ্বীপ। কথিত আছে ওসমান নামের এক ব্যক্তি তার মহিষের পাল নিয়ে সর্বপ্রথম এই দ্বীপে নববসতি গড়ার পর তার নামেই দ্বীপটি পরিচিতি পায়। ৭০'এর দশকের পর দ্বীপের নামকরণ হয় নিঝুম দ্বীপ।

3. Read the following passage and write a summary of no more than 120 words.

6

Thais give a great deal of thought and time to the planning and preparation of their meals. There is an infinite variety of recipes from which they can choose, and rarely would a household repeat the same dish within a fortnight.

The staple food is rice which is the base for most meals. The most commonly-used meats are pork and chicken, with a little beef. Fresh fish and other seafood are plentiful and very popular. Fish can be eaten fresh, salted, dried, fermented and in many other ways. Vegetables too come in profuse variety and are unbelievably cheap. Green leafy vegetables, shoots, roots and young leaves are popular in salads and soups. Even pumpkins and watermelons are used in soups.

Normally, breakfast in a Thai household would probably consist of a lightly boiled egg or rice soup, followed by 'ba ton ko' which are crisp, hollow, fried roots, often dipped in condensed milk. Lunch is likely to feature one of many different sorts of noodles available; and perhaps, dumplings made from flour and sago with a savory filling. The main meal of the day is usually taken early in the evening, with rice as the base for the accompanying dishes such as curried meat, fish, vegetables and noodles. Other savory concoctions generally called 'kap khoa' are prepared with great care and add to the main course. Sweet meats and dishes and fresh fruits, complete the meal. A glass of water is the usual drink taken with the meal.

In Thailand, people virtually eat all day long as it is very convenient to buy snacks. Food vendors station themselves outside offices during the day and outside cinemas at night. Other vendors ride bicycles or motorcycles peddling their wares. When traveling by train, the most outstanding feature of the journey is the rush of food vendors every time the train stops at a station. They offer drinks, sweets and even hot dishes like rice and chicken. However, these vendors are slowly disappearing as commuters are more careful about the food they eat.

Thais do not customarily mix everything into one plate, but take one serving at a time, to be eaten before proceeding to the next. Meals are eaten with a fork and spoon. Noodles are often taken in Chinese fashion with chopsticks.

4. Narrate how you celebrated the last "Pohela Falgun". 6

5. Write an essay of around 250 words on any one of the following: 6

a. Do you agree that the body weight of people of today's world is increasing? Discuss why or why not.

Or,

b. Sports can be the international arrangement that can encourage and improve the relationship of the global community. Argue for or against the statement.

6. Analyze the subject+ verb+ object/complement+ adjunct (if any) of any eight of the following sentences: 8

(Use "/" and underline prominently the clause/ phrase mentioning the element)

a. A barometer measures the pressure of the air.

b. Leave this arena at once!

c. She may do whatever she wishes if she behaves well.

d. Maria has never walked here before.

e. I have just ninety-seven cents.

f. He is a very good cook.

g. One dollar will buy your book of admission tickets.

h. In a rainy forest, twenty-four people sat together to eat.

i. The computer was slow.

j. The magazines on the table are all very interesting.

k. He kept all the books on the shelf.

l. Don't spend beyond your limit.

m. The boy learns his lessons very attentively.

7. Rewrite the following passage, marking corrections in capitalization and punctuation: 5

located at shibli gunj some three kilometres west of historic charminar the 144-year-old islamic university still stands tall equated with al azhar university of cairo for its standard of education jamia nizamia has about 3,000 manuscripts including the over 400-year-old translation of the mahabharata and books written by renowned indian and arabic islamic scholars translated by abu'l-fazal, one of the navratnas (nine jewels) of mughal emperor akbar's royal court the mahabharta runs into 5,012 pages it was in the personal collection of moulana mohammad anwarullah farooqui the founder of jamia the biggest seminary in southern india

8. Use the following words, phrases and clauses in sentences; 5

- a. ...as everything else was unsuccessful
- b. a portable radio
- c. ... for all of us
- d. Magnificent
- e. ...about their intention

University of Asia Pacific
Department of Basic Sciences & Humanities
Semester Final Examination, Fall-2014
Program: B. Sc. Engineering (Civil)
1st year/ 1st semester

Course Title : Calculus I
 Time: 3 Hours

Course Code: Math 101
 Full Marks: 150

N.B.: Answer 6 questions taking any 3 questions from each group. Figures in the right margin indicate the marks of the respective questions.

GROUP-A

- Q1. (a) State and prove Lagrange's mean value theorem (MVT). 12.5
 (b) Verify this theorem for $f(x) = x^2 - x - 4$ on the interval $[0, 3]$. 12.5
- Q2. (a) State Cauchy's mean value theorem (MVT). 5
 (b) Verify Cauchy's mean value theorem for $f(x) = x^3 - 3x^2 + 4$ and $g(x) = x^2 - x - 2$ on the interval $[1, 2]$. 10
 (c) Verify Rolle's MVT for $f(x) = x^2 - 6x + 8$ on the interval $[2, 4]$. 10
- Q3. (a) Let $f(x) = \frac{1}{3}x^3 - 3x^2 + 8x$. Find the intervals on which the function $f(x)$ is (i) 12.5
 increasing, (ii) decreasing, (iii) concave up and (iv) concave down.
 (b) Define relative extrema. Find the relative extrema of $f(x) = \sin x (1 + \cos x)$. 12.5
- Q4. (a) State Taylor's theorem with remainder. Use Taylor's theorem to 12.5
 expand $f(x) = \sin x$ in powers of $\left(x - \frac{\pi}{2}\right)$ with the remainder term.
 (b) State and prove L' Hospital's rule. Apply this rule to evaluate 12.5

$$\lim_{x \rightarrow 0} \left(\frac{\ln(\cos x)}{\ln(\cos 3x)} \right)$$

GROUP-B

- Q5. Evaluate the following indefinite integrals: 25
 (i) $\int_0^1 \frac{dx}{5 + 4 \cos x}$ (ii) $\int \frac{dx}{(e^x + e^{-x})^2}$ (iii) $\int \frac{\sin^{-1} x}{\sqrt{1-x^2}} dx$
 (iv) $\int \frac{dx}{2x^2 + x + 1}$ (v) $\int \frac{dx}{\sqrt{(x-2)(3-x)}}$
- Q6. (a) State the fundamental theorem of calculus. 5
 (b) Evaluate the following definite integrals: 20

$$(i) \int_0^2 \left(\frac{1}{x} - x^2 \right) dx \quad (ii) \int_0^1 (\sqrt{x} - e^{3x}) dx \quad (iii) \int_0^{\frac{\pi}{2}} (\cos 4x) dx \quad (iv) \int_{-4}^2 (x^5 - 3) dx \quad (v)$$

$$\int_0^{\frac{\pi}{2}} \frac{dx}{3 + 2 \cos x}$$

Q7.

(a) Define reduction formula. Find a reduction formula for $\int \sin^n x dx$. Hence 15

evaluate $\int \sin^3 x dx$

(b) Find a reduction formula for $\int x^3 e^{2x} dx$ 10

Q8. (a) Find the area of the region enclosed by the curves $y^2 = x$ and $x^2 = y$ 12.5

(b) Find the area of the region that is inside the cardioids $r = 4(1 + \cos \theta)$ and outside the circle $r = 6$. 12.5

University of Asia Pacific
Department of Basic Sciences and Humanities
Final Examination Fall – 2014
Program: B. Sc Engineering (Civil)

Course Title: Physics I
Time: 3.00 Hours

Course Code: PHY-101

Credit: 3.00
Full Marks: 150

[N.B- The figures in the right margin indicate marks. There are two sections in the question paper namely "SECTION A" and "SECTION B". Answer from both sections according to the instruction mentioned in each section.]

SECTION A

There are FOUR questions. Answer any THREE

1. (a) Derive the expressions for the apparent pitch when the observer moves towards and away from a stationary source. [15]

- (b) A motor car sounding a horn at a frequency of 100 hertz moves away from a stationary observer towards a rigid flat wall with a velocity of 36 km/hr. How many beats per second will be heard by the observer? [Velocity of sound = 350 m/s] [10]

2. (a) Discuss about how Laplace made correction to Newton's formula and prove that the equation of Laplace's correction to Newton's formula for velocity of sound in gas can be written as $V = \sqrt{\frac{\gamma P}{\rho}}$. Where P is pressure and ρ is density of the gas. [15]

- (b) Discuss the effect of temperature on the velocity of sound in gas. [10]

3. (a) How can you prove that the total energy of the simple harmonic oscillator is given by [15]

$$E = \frac{1}{2} kA^2$$

where E is the total energy and A is the amplitude of the simple harmonic oscillator.

- (b) For a particle vibrating simple harmonically the displacement is 8 cm at the instant the velocity is 6 cm/s and the displacement is 6 cm at the instant the velocity is 8 cm/s. Calculate (i) amplitude (ii) frequency and (iii) time period. [10]

4. (a) Prove that the differential equation of a progressive wave can be written as [15]

$$\frac{d^2 y}{dt^2} = v^2 \frac{d^2 y}{dx^2}$$

where v is the velocity and y is the displacement of the wave.

- (b) A particle executes simple harmonic motion given by the equation $y = 12 \sin\left(\frac{2\pi t}{10} + \frac{\pi}{4}\right)$ [10]
calculate (i) amplitude, (ii) frequency, (iii) epoch, (iv) acceleration at $t = 5$ s.

SECTION B

There are FOUR questions. Answer any THREE

5. (a) State and explain the laws: Zeroth law of thermodynamics, First law of thermodynamics, Second law of thermodynamics. [15]
- (b) When a system is taken from the state A to state B along the path ACB , 80 joules of heat flows into the system and the system does 30 joules of work (fig. below). [10]

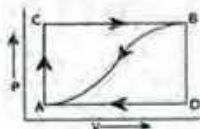

- (i) How much heat flows into the system along the path ADB , if the work done is 10 joules?
- (ii) The system is returned from the state B to the state A along the curved path. The work done on the system is 20 joules. Does the system absorb or liberate heat and how much?
- (iii) If $U_A = 0$, $U_B = 40$ joules, find the heat absorbed in the process AD and DB .
6. (a) Show that the work done for expanding the gas during an adiabatic process can be expressed by the equation $W = \frac{1}{1-\gamma} [RT_2 - RT_1]$, where the symbols have their usual meaning. [15]
- (b) A motor car tyre has a pressure of 2 atmospheres at room temperature of 27°C . If the tyre suddenly bursts, find the resulting temperature. [10]

7. (a) Derive that the difference between the two principle specific heats of a gas can be written as [15]

$$C_p - C_v = R$$

Where C_p and C_v are the specific heat at constant pressure and constant volume respectively.

- (b) A quantity of air at 27°C and normal atmospheric pressure is suddenly compressed to half its original volume. Find the final pressure and temperature. [10]
8. (a) Prove that the efficiency of the Carnot's heat engine in terms of temperature is given by the relation [15]

$$\eta = 1 - \frac{T_2}{T_1}$$

Where T_1 and T_2 are the temperatures of source and sink respectively.

- (b) A Carnot's engine whose temperature of the source is 400 K takes 200 calories of heat at this temperature and rejects 150 calories of heat to the sink. What is the temperature of the sink? Also calculate the efficiency of the engine. [10]

University of Asia Pacific
Department of Civil Engineering
Final Examination Fall 2014
Program: B.Sc Engineering (Civil)

Course Title: Engineering Mechanics I
 Time: 3.0 hours

Course Code: CE 101
 Full Marks: 10 x 10 = 100

Answer any 10 (Ten) of the following 14 Questions
The symbols have their usual meanings.

1. Find the resultant of the force system shown below.

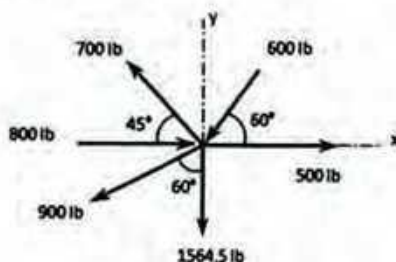

2. In the following figure, find the reactions at A and B. Given that $W_{\text{SPHERE}} = 500$ lb (assume all surfaces smooth and frictionless).

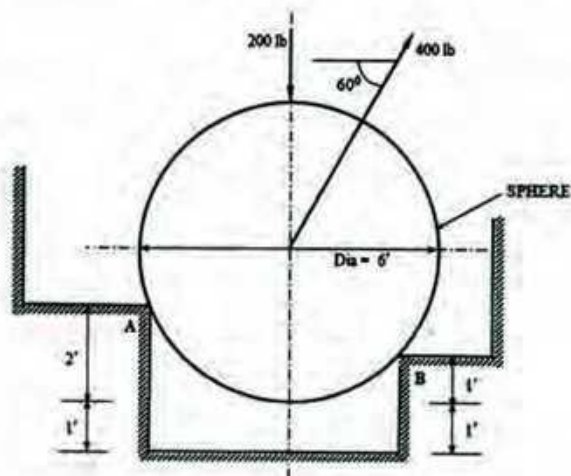

3. In the beam shown below, calculate the reactions at supports A, B, F, G and the bending moment at B.

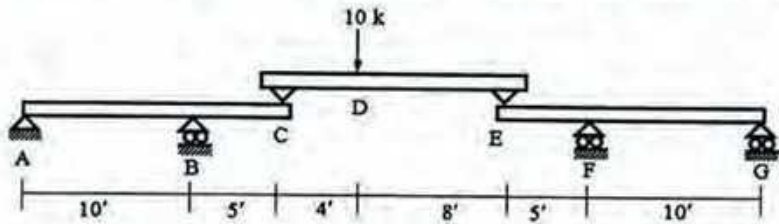

4. In the structure shown below, calculate the force in member EC and the reactions at pin B.

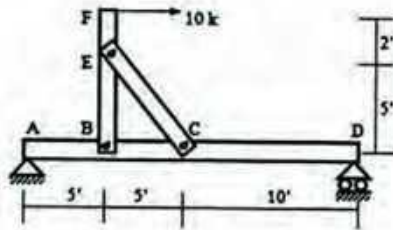

5. In the structure shown below, the weight of sphere G is 10 lb and member ABCD is 20 lb. Calculate the force in EB and the reactions at D. Also draw the free-body diagram of ABCD.

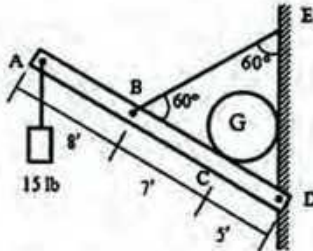

6. Find the forces in members AB, BG, DG and DE of the following truss.

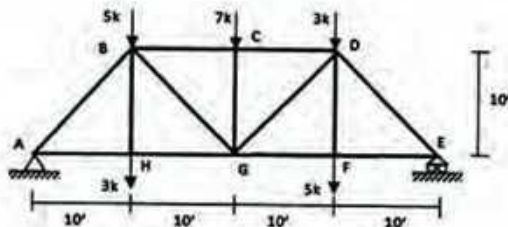

7. A cable weighing 2 lb per ft. is 400 ft long. The distance between the points of support, which are on a horizontal, is 398 ft. Compute the sag and the maximum tension in the cable.

8. On the horizontal boom of the figure, are placed three loads, F , $2F$ and $3F$, as shown. What value of F will produce a thrust of 30,000 lb. on the strut BC. What are the vertical and horizontal components of the resulting pin load at A?

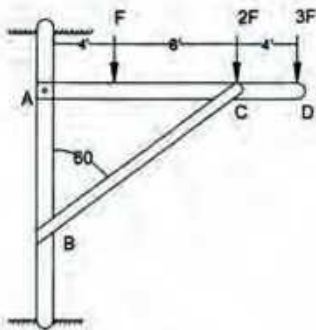

9. What are the theorems of Pappus and Guildinus ? Prove the theorems.

10. An area is bounded by the parabola $y^2 = 8x$ and the straight line $x = 5$ in. Determine by integration the centroid of this area.

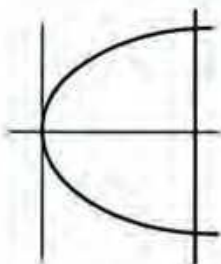

11. Determine the centroid of the following composite area.

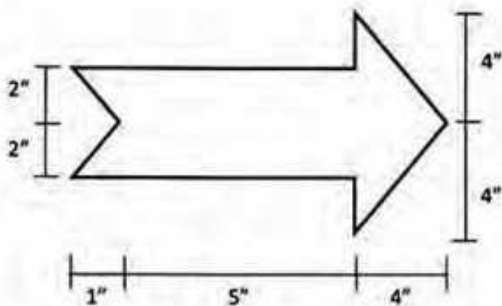

12. A right circular cone of homogenous material has a diameter $D = 20''$, a height $h = 30''$. A cylindrical hole, whose geometric axis is coincident with that of cone, is bored in the base. This hole has a diameter $d = 8''$ and a depth $b = 6''$. Locate the center of gravity of the cone with the hole. Figure is given below.

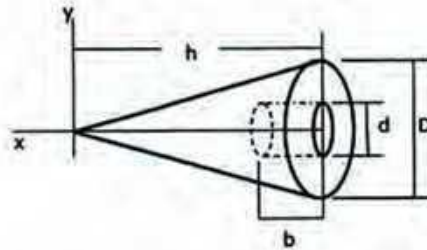

13. Find the moment of inertia about the axis M-M as shown in the following composite section.

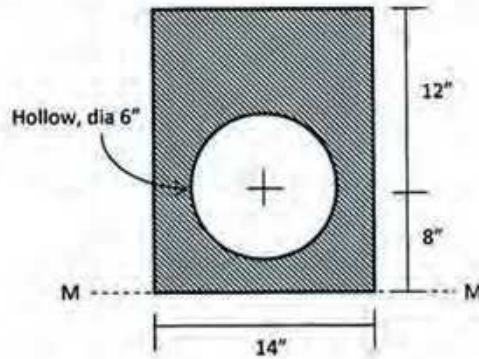

14. For a standard structural steel angle, figure below, $a = 1 \text{ in}$, $b = 6 \text{ in}$, $c = 8 \text{ in}$, $\bar{x} = 2.65 \text{ in}$, $\bar{y} = 1.65 \text{ in}$,

$I_x = 38.8 \text{ in}^4$, $I_y = 80.8 \text{ in}^4$. Locate the principal axes and determine the least radius of gyration.

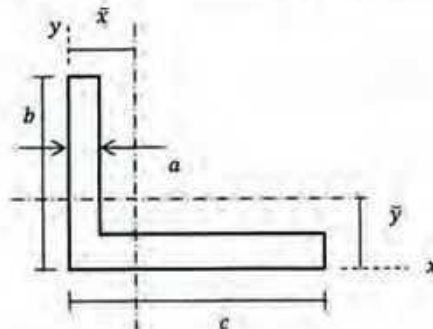

University of Asia Pacific
Department of Civil Engineering
Final Examination Fall 2014
Program: B.Sc. Engineering (Civil)

Course Title: Engineering Mechanics II
 Time: 3.0 hr

Course Code: CE 103
 Full Marks: 100

[Answer any ten (10) out of the following fourteen (14) questions]

Full Marks: 100 [=10*10]

[Assume reasonable values for any missing data]

1. What weight W is necessary to start the system of blocks shown in the figure below moving to the left? The co-efficient of friction for Plane AB is 0.3 and AC is 0.5 and the pulleys are smooth.

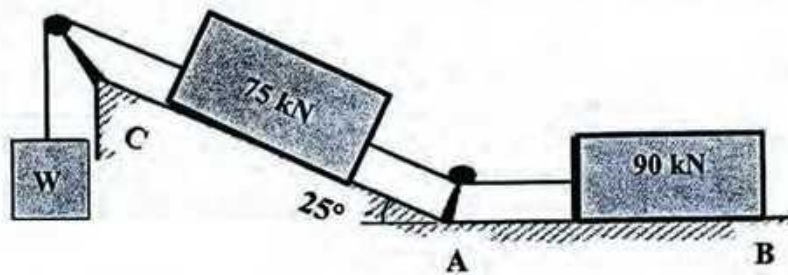

2. A homogeneous block of weight W rests upon the incline shown below. If the co-efficient of friction is 0.25, determine the greatest height h at which a force P parallel to the incline may be applied so that the block will slide up the incline without tipping over. Also calculate the value of P when $W = 50$ kN.

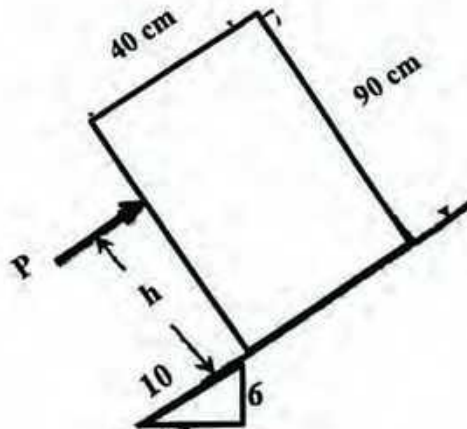

3. In the following figure, determine the minimum weight of block B that will keep it at rest while a force P starts block A up the inclined surface of B. $W_A = 250 \text{ lb}$ and angle of friction for all surfaces in contact is 32° , what is the value of P ?

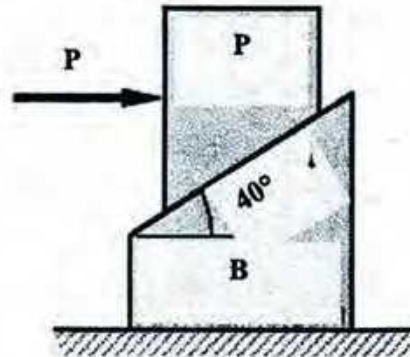

4. The pendulum is suspended from point O and consists of two thin rods, each having a weight of 65 N . Determine the pendulum's moment of inertia about the z axis.

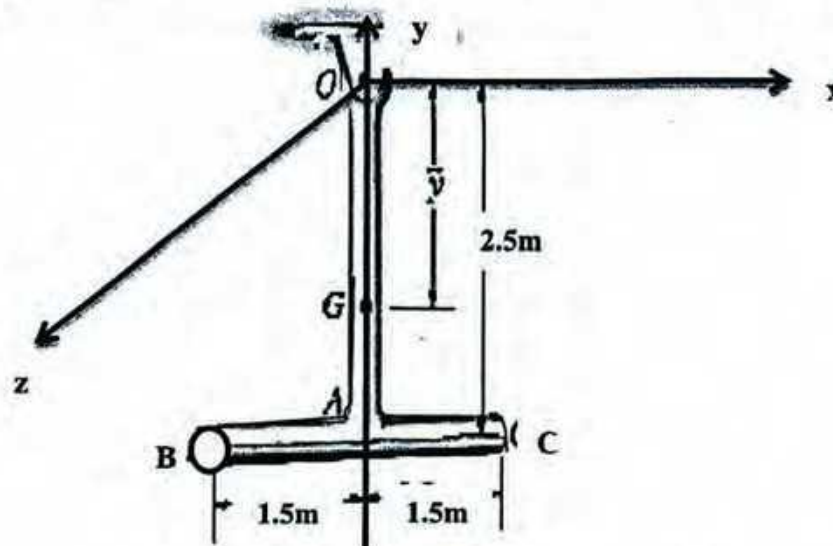

5. If the plate shown below has a density of 9000 kg/m^3 and a thickness of 25 mm , determine its moment of inertia about an axis directed perpendicular to the page and passing through point P.

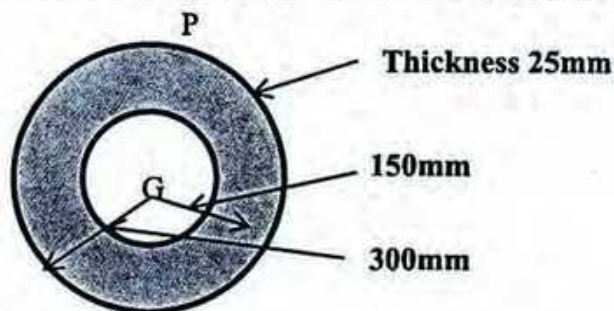

6. In the figure below, weight of rod, $W_{AB} = 250\text{lb}$. If the reaction at B is 25lb upward and $f_k = 0.3$, find resultant acceleration of the mass center of slender rod, \ddot{a} and force Q.

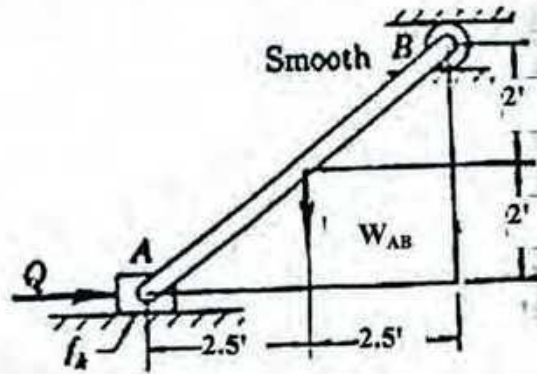

7. In the figure below, the body A weighs 1500lb . Let $\theta = 36^\circ$ and $f_A = 0.25$. The pulleys are weightless and frictionless.

- Determine the weight W when body A is on the point of turning over.
- Determine corresponding tension in the weightless cord.

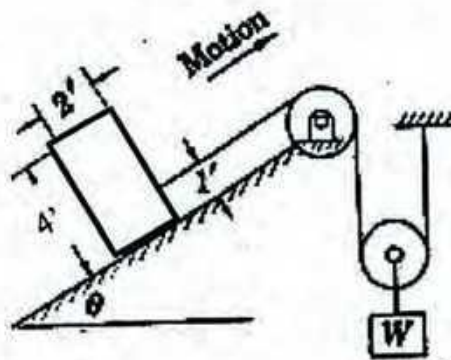

8. In the figure, Weight A is supported from a cable which is wound about a 4-ft drum. An 8ft flywheel turns with the drum. The total weight of the rotating drum is 1288lb and the radius of gyration is 3 ft . While A travels 65ft vertically downward, the speed of the rotating parts changes from 20rpm to 180 rpm . The frictional force in the bearings acting tangentially to the 6 in shaft is $F=70\text{lb}$. What is the weight W of A?

(Note: Use Work Energy Principle to solve the problem)

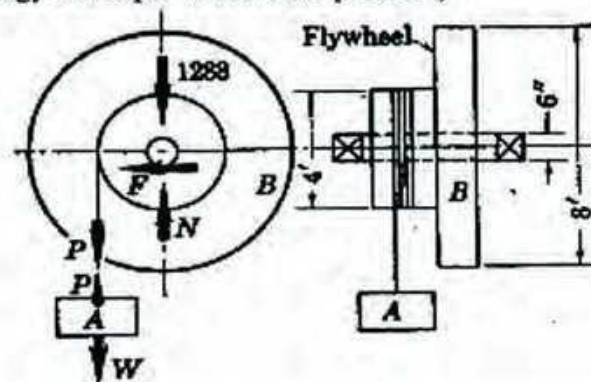

9. The weight of the rotating drum assembly B is 3000 lb and its radius of gyration with respect to the axis is 14 inch. The weight is suspended from a cable which wraps about the $D = 40$ inch in diameter. While W moves downward through a distance of 55ft, the speed of the drum is increased from 20 rpm to 60 rpm. If the frictional effects are negligible, what is the weight of W ? (Note: Use Work Energy Principle to solve the problem.)

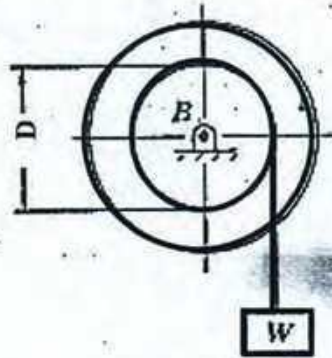

10. A point P moves in the path of the parabola, $x^2 + 75y = 15625$, so that $V_x = \text{a constant}$ and $a_y = -g$. Determine the magnitude and direction of its velocity when the point is at the position $(-125, 0)$.

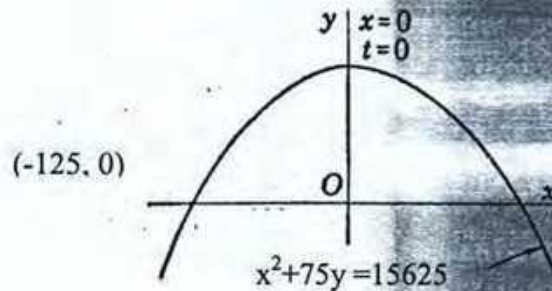

11. In the given figure, sliding members A and B are constrained to move at all times in the y and x directions respectively. They are connected by the rod whose length is, $L = 34$ ft. At the instant, when $x = 21$ ft, $V_B = 37$ fps towards the right and $a_B = -29$ fps^2 towards the left. Determine

- Value of y when $x = 21$ ft
- Velocity of A, V_A
- Acceleration of A, a_A at this instant.

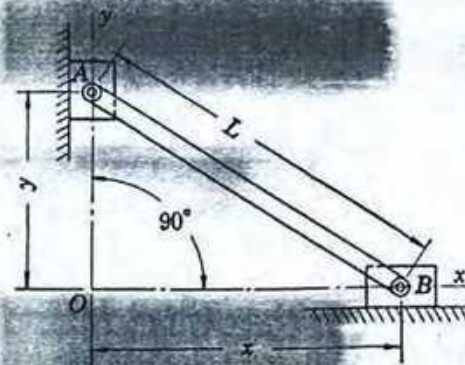

12. A box of sand A weighing 15lb is moving left on a horizontal plane, where $f=0.4$ with $V_A=6\text{fps}$. The box is struck by a bullet B weighing 0.5lb, moving right with $V_B=1500\text{fps}$. The bullet embeds itself in the box.
- What is the resulting velocity of the box?
 - When does the box come to rest?
 - How far does it move from the point of impact?

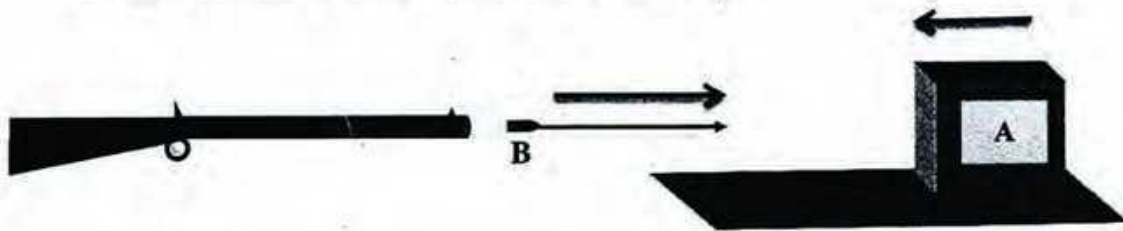

13. A 745 lb disk, 7ft diameter, is keyed to 322lb shaft which is 4inch in diameter. The shaft is turning 845 rpm, where $f=0.04$. If there is no torque on the rotating members except that due to the frictional force in the bearings, how long does it take for the angular speed to be reduced to 250rpm (Use Impulse-momentum principle).

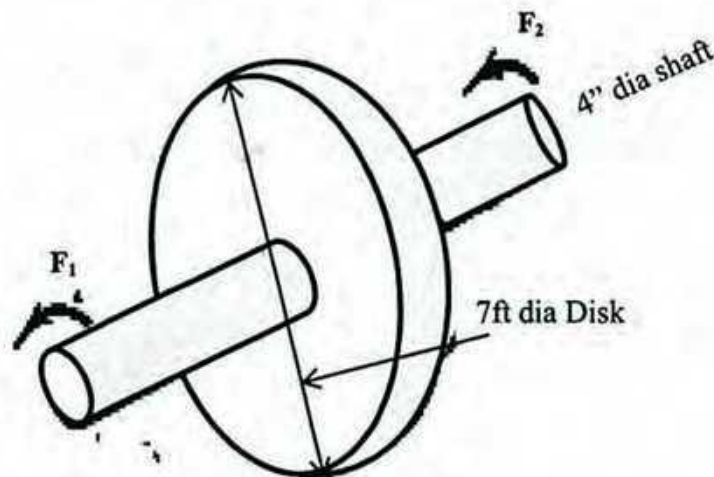

14. Determine the force in each cable (AB, AC, AD) to support the 60lb crate shown in the figure below.

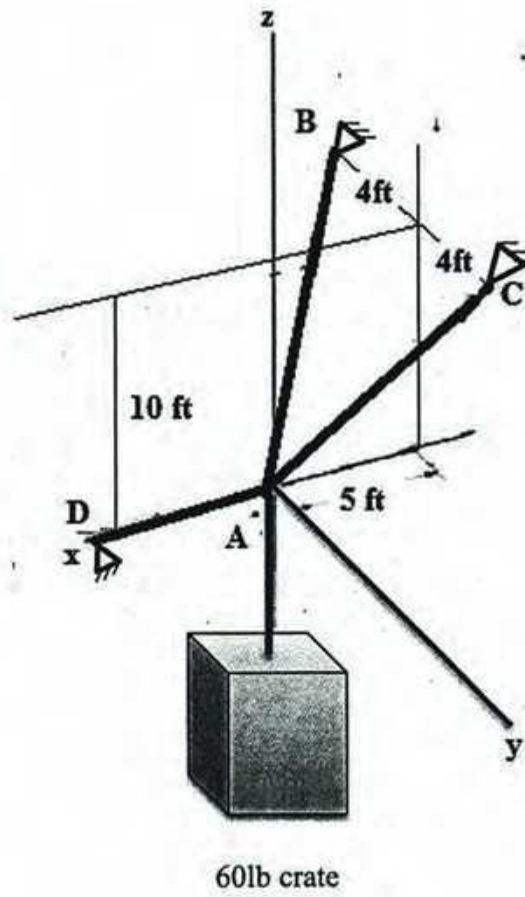

University of Asia Pacific
Department of Civil Engineering
Final Examination Fall 2014
Program: B.Sc. Engineering (Civil)

Course Title: Surveying
 Time: 3 hours

Course Code: CE 105
 Full Marks: 100

SECTION I

(There are **Four** questions in this section. Answer any **Three** of them.)

1. (a) What are the characteristics of contour lines? (03)
 (b) Draw contour lines of 20m, 25m and 28m for the grid shown in Figure 1(b). (09)
 (c) Draw simple, compound, reverse and broken-back curves. (04 $\frac{2}{3}$)
2. (a) What is transition curve? What are the functions of a transition curve? (04)
 (b) Explain curve setting method by radial offset from the tangent. (with figure) (06)
 (c) Define mid ordinate, apex distance, deflection angle, super-elevation and tangent distance. (06 $\frac{2}{3}$)
3. (a) Explain the working principle of GPS. (06 $\frac{2}{3}$)
 (b) A roadway embankment with formation width of 10 m and side slope of 2H:1V is to be constructed. The ground level along the center line is as follows: (10)

Chainage	0	30	60	90	120
GL(m)	102	105	97	106	104

The embankment formation level has a rising gradient of 1 in 60 and the formation level at zero chainage is 100 m. Assuming the ground is level across the center line, compute the volume of earth works. (both cutting and filling)
4. (a) Draw level section, two level section and three level section. (03)
 (b) The following offsets were taken from a chain line to an irregular boundary line at an interval of 10 ft (All offset values are in ft): (08)
 0, 2.15, 3.05, 2.55, 1.55, 2.12, 3.15, 2.25, 1.25
 Compute the area formed by the chain line, the irregular boundary line and the end offsets by
 i. The mid ordinate rule
 ii. The trapezoidal rule
 iii. Simpson's rule
 iv. Average ordinate rule
 (c) What is GPS? Write the name of different segments of GPS. (05 $\frac{2}{3}$)

SECTION II

(There are **Four** questions in this section. Answer any **Three** of them.)

5. (a) Explain plan table survey basics. (05)
 (b) Explain intersection method of plane table surveying. (07)

- (c) Briefly explain remote sensing. (04 $\frac{2}{3}$)
6. (a) What is project survey? Briefly explain reconnaissance and detail engineering survey. (06 $\frac{2}{3}$)
- (b) What is astronomical surveying? What are the applications of astronomical surveying? (05)
- (c) Define latitude and longitude. Show tropic of cancer and tropic of capricorn in a qualitative figure. (05)
7. (a) What do you mean by scale of photograph? What are the reasons of overlapping? (04 $\frac{2}{3}$)
- (b) Differentiate between terrestrial and aerial photogrammetry. (03)
- (c) The scale of an aerial photography is 1 cm = 50 m. The photograph size is 15 cm x 10 cm. Determine the number of photographs required to cover an area of 200 sq. km if the longitudinal lap is 60% and the side lap is 40%. (09)
8. (a) Determine the values of stadia constants from the following observation (13)

Instrument station	Staff reading on	Distance (m)	Stadia readings (cm)	
			Upper	Middle
O	P	50	25.5	20.5
	Q	35	30.5	27.5
	R	80	25	15

- i. Determine the values of stadia constants.
 - ii. A staff is placed at point S where upper and lower stadia readings were found to be 55 cm and 30 cm respectively. Find the distance between point O and S.
- (b) What is the principle of tacheometric surveying? (03 $\frac{2}{3}$)

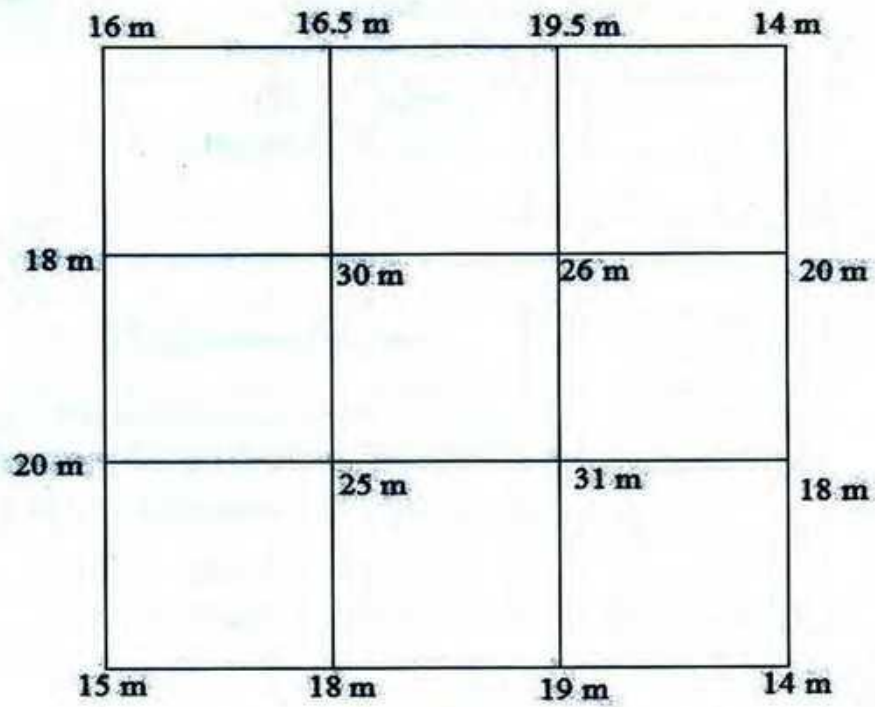

Figure 1(b)

Formula:

For a level Section,

$$A = (b+sh)h$$

University of Asia Pacific
Department of Civil Engineering
Final Examination Fall 2014
Program: B.Sc Engineering (Civil)

Course Title: Surveying
Time: 3 Hours

Course Code: CE 105
Full Marks: 120

Section- A :Answer any 3 (Three) out of 4 (Four)

1. (a) Define Chain Survey. Write down the name of different instruments used for chain survey. (05)
- (b) Define check line, tie station and tie line with a figure. (04)
- (c) A distance measured by using a 100 ft chain was 1840 ft. Standard pull and standard temperature for the chain was 30 lb and 85° F respectively. However, the force pulled to pull the chain was a 20 lb and field temperature was 75° F. Calculate the correct distance. Given $A=0.05 \text{ cm}^2$, $E= 2.109 \times 10^6 \text{ kg/cm}^2$. (neglect correction for sag) (11)
2. (a) Define true meridian and magnetic meridian. (04)
- (c) A line has true bearing of N 25° W and magnetic bearing of N 45° W. Find the declination angle of the line. (06)
- (d) A closed traverse was conducted and following observations were made. Find out the missing quantities. (10)

Side	Length(m)	Bearing(W.C.B)
AB	500	98°30'
BC	620	30°20'
CD	468	298°30'
DE	?	230°0'
EA	?	150°10'

3. (a) Draw the figure of a circular curve and show its various components. Write down the factors affecting the location and configuration of horizontal alignment of a curve. (10)

- (b) Define contouring. Write down the characteristics of a contour. (10)
4. (a) What are the differences between chain survey and traverse survey? (05)
- (b) The following figures were extracted from a levelling field book, some of the entries being illegible due to exposure to rain. Insert the missing figures and check your results. Rebook all the figures by the rise and fall method. (15)

Station	B.S.	I.S.	F.S.	Rise	Fall	RL	Remarks
1	2.285					232.46	B.M. 1
2	1.650		?	0.020			
3		2.105			?		
4	?		1.960	?			
5	2.050		1.925		0.300		
6		?		?		232.255	B.M. 2
7	1.690		?	0.340			
8	2.865		2.10		?		
9			?	?		233.425	B.M. 3

Section- B: Answer any 3 (Three) out of 4 (Four)

5. (a) What do you mean by tacheometric survey? What are the characteristics of tacheometer? (08)
- (b) The following data is found from reciprocal levels. (12)

Instrument At	Staff readings on		Remarks
	P	Q	
P	2.824	1.748	Distance PQ=2050 m
Q	1.928	1.006	RL of P=125.000

Find the angular error in the collimation adjustment of the instrument. Also find the elevation of Q.

6. (a) Write down the steps in levelling with figure. (06)
- (b) Distance between two points A and B is 2.5 km. The level and staff are placed at A and B and staff reading is found to be 7.405 ft. Distance from point A to observer's eye is 3 ft and RL of point B is 558.59m. Find the elevation of A, considering error due to curvature and refraction only. (14)

7. (a) Write down the procedure of drawing perpendicular offset from tangent of a circular curve. (08)
- (b) What do you mean by transition curve? What are the primary functions of a transition curve? (12)
8. (a) What do you mean by photogrammetry survey? What are the functions of Oop (Office of Photogrammetry)? (08)
- (b) Determine the values of stadia constants from the following observations. (12)

Instrument Station	Staff reading on	Distance (m)	Stadia Reading	
			Lower	Upper
O	A	150	1.255	2.750
	B	200	1.000	3.000
	C	250	0.750	3.255

University of Asia Pacific
Department of Civil Engineering
Final Examination Fall 2014
Program : B.Sc Engineering (Civil)

Course Title: Chemistry
Time: 3 hours

Course Code: CHEM111
Full Marks: 150

Section: A

There are FOUR questions in this section. Answer any THREE.

1. (a) What is solution? What are the different types of solution? [7]
(b) Explain the freezing point depression and boiling point elevation by drawing the phase diagram of water upon addition of a non-volatile solute. [10]
(c) An aqueous solution is 0.0222 *m* glucose. What are the boiling point and the freezing point of this solution? Boiling-point-elevation constant (K_b) and freezing-point-depression constant (K_f) of water are 0.512 and 1.858 °C/*m* respectively. [8]
2. (a) State and explain Raoult's law. Define ideal and non-ideal solution. [10]
(b) Camphor is a white solid that melts at 179.5 °C. It has been used to determine the molecular masses of organic compounds because of its unusually large freezing-point-depression constant (40 °C/*m*), which allows ordinary thermometers to be used. The organic substance is dissolved in melted camphor, and then the melting point of the solution is determined.
 - i. A 1.07-mg sample of a compound was dissolved in 78.1 mg of camphor. The solution melted at 176.0 °C. What is the molecular mass of the compound?
 - ii. If the empirical formula of the compound is CH, what is the molecular formula? [15]
3. (a) Define lattice energy and hydration energy. How do they play role in determining the solubility of an ionic solid in water? [12]
(b) Estimate the freezing point of a 0.010 *m* aqueous solution of aluminum sulfate, Al₂(SO₄)₃. Assume the value of 'i' based on the formula of the compound. Freezing-point-depression constant (K_f) of water is 1.858 °C/*m*. [13]
4. (a) Define rate of reaction. What are the parameters that influence the rate of a reaction? [8]
(b) Calculate the average rate of decomposition of N₂O₅, $-\Delta[N_2O_5]/\Delta t$, by the reaction $2N_2O_5(g) \rightarrow 4NO_2(g) + O_2(g)$ during the time interval from $t = 600$ s to $t = 1200$ s. Use the following data:

Time	$[N_2O_5]$
600 s	$1.24 \times 10^{-2} M$
1200 s	$0.93 \times 10^{-2} M$

[9]
(c) Shown below is a plot of the concentration of a reactant D versus time.
 - i. How do the instantaneous rates at points A and B compare?
 - ii. Is the rate for this reaction constant at all points in time?



[8]

Section: B

There are FOUR questions in this section. Answer any THREE.

5. (a) Define equilibrium constant. [5]
 (b) Write down the equilibrium constant expression for the following chemical reactions:

$$\text{CO}(g) + 3\text{H}_2(g) \rightleftharpoons \text{CH}_4(g) + \text{H}_2\text{O}(g)$$

$$\text{CH}_4(g) + \text{H}_2\text{O}(g) \rightleftharpoons \text{CO}(g) + 3\text{H}_2(g)$$

$$\text{N}_2(g) + 3\text{H}_2(g) \rightleftharpoons 2\text{NH}_3(g)$$

$$\frac{1}{2}\text{N}_2(g) + \frac{3}{2}\text{H}_2(g) \rightleftharpoons \text{NH}_3(g)$$
 [10]
 (c) Carbon monoxide and hydrogen react according to the following equation:

$$\text{CO}(g) + 3\text{H}_2(g) \rightleftharpoons \text{CH}_4(g) + \text{H}_2\text{O}(g)$$
 When 1.000 mol CO and 3.000 mol H₂ are placed in a 10.00-L vessel at 927°C (1200 K) and allowed to come to equilibrium, the mixture is found to contain 0.387 mol H₂O. What is the molar composition of the equilibrium mixture? That is, how many moles of each substance are present? [10]
6. (a) What is the relationship between the equilibrium constants K_p and K_c ? What will be K_p for the methanation reaction if $K_c = 3.92$? The reaction is:

$$\text{CO}(g) + 3\text{H}_2(g) \rightleftharpoons \text{CH}_4(g) + \text{H}_2\text{O}(g)$$
 [4+6]
 (b) Define reaction quotient, Q_c . Predict the direction of the above methanation reaction if
 i. $Q_c > K_c$, ii. $Q_c = K_c$, iii. $Q_c < K_c$ [6]
 (c) A 50.0-L reaction vessel contains 1.00 mol N₂, 3.00 mol H₂, and 0.500 mol NH₃. Will more ammonia, NH₃, be formed or will it dissociate when the mixture goes to equilibrium at 400°C? The equation is:

$$\text{N}_2(g) + 3\text{H}_2(g) \rightleftharpoons 2\text{NH}_3(g)$$
 K_c is 0.500 at 400°C. [9]
7. (a) Define enthalpy. Explain why enthalpy is an extensive property and why it is a state function. [8]
 (b) What is internal energy? Derive a relationship between enthalpy change and internal energy change. [9]
 (c) Use values of ΔH_f° (ΔH_f° for CS₂(g) is 116.9 kJ/mol and CS₂(l) is 89.70 kJ/mol) to calculate the heat of vaporization, $\Delta H_{\text{vap}}^\circ$, of carbon disulfide at 25°C. The vaporization process is:

$$\text{CS}_2(l) \longrightarrow \text{CS}_2(g)$$
 [8]
8. (a) Describe a coffee-cup calorimeter. [8]
 (b) What is the enthalpy of reaction, ΔH , for the formation of tungsten carbide, WC, from the elements?

$$\text{W}(s) + \text{C}(\text{graphite}) \longrightarrow \text{WC}(s)$$
 The enthalpy change for this reaction is difficult to measure directly, because the reaction occurs at 1400°C. However, the heats of combustion of the elements and of tungsten carbide can be measured easily using the following thermochemical equation:

$$2\text{W}(s) + 3\text{O}_2(g) \longrightarrow 2\text{WO}_3(s); \Delta H = -1685.8 \text{ kJ} \quad (1)$$

$$\text{C}(\text{graphite}) + \text{O}_2(g) \longrightarrow \text{CO}_2(g); \Delta H = -393.5 \text{ kJ} \quad (2)$$

$$2\text{WC}(s) + 5\text{O}_2(g) \longrightarrow 2\text{WO}_3(s) + 2\text{CO}_2(g); \Delta H = -2391.8 \text{ kJ} \quad (3)$$
 [11]
 (c) Define heat of formation. Explain why it is important in thermochemistry. [6]

University of Asia Pacific
Department of Civil Engineering
Final Examination Fall 2014
Program: B.Sc Engineering (Civil)

Course Title: English Language II

Time: 3.00 Hours

Course Code: HSS 103

Full Marks: 50

* Marks are indicated in the right margin

1. Read the following passage and answer the questions that follow:

The **Bangladesh Army** is the land forces branch and the largest of the three uniformed service of the Bangladesh Armed Forces. The primary mission of the Army is to provide necessary forces and capabilities in support of Bangladesh's security and defence strategies including defence of the nation's territorial integrity against external attack. Control and operations are administered by the Department of the Army of the Armed Forces Division. The civilian head is the Prime Minister, who by law also holds the defence ministry portfolio. Presently the size of the army is 180,000 and the Headquarters is in Dhaka Cantonment. The motto of Bangladesh Army is "*In War, In Peace, We are Everywhere for our Country*". The Bangladesh Army has been actively involved in a number of United Nations Peace Support Operations (UNPSO) since its formation in the 1970s. Its first deployments came in 1988, when it participated in two operations – UNIIMOG in Iraq and UNTAG in Namibia. Later, as part of the UNIKOM force deployed to Kuwait and Saudi Arabia following the Gulf War, the Bangladesh Army sent a mechanised infantry battalion (approx. 2,193 personnel). Since then, the Bangladesh Army has been involved in up to thirty different UNPKOs (United Nations Peace Keeping Operations) in as many as twenty five countries. As a result of its contributions to various UN peacekeeping operations, up to 88 Bangladeshi soldiers have lost their lives (as of February 2009). However, the performance of Bangladesh's contingents has been described as being of the "highest order" and the appointment of several senior Bangladesh military officers as the Commander of UN peacekeeping missions and Senior Military Liaison Officers. In January 2004, BBC described the Bangladeshi UN Force as "**Cream of UN Peacekeepers**". UN peacekeepers are often referred to as **Blue Berets** or **Blue Helmets** because of their light blue berets or helmets. Bangladesh Armed Forces participated in the Gulf war in 1991 in *Operation Desert Storm*.

Bangladesh Military Academy (BMA) is the training institute for the officer cadets of Bangladesh Army. It is located in Bhatiary, near **Chittagong Hill Tracts**, in **Chittagong** of south-east Bangladesh, about 13 kilometres north of Chittagong city. The Academy is situated on the slopes of the Sitakunda hill ranges and the shore of the Bay of Bengal. The Academy was initially established at Comilla Cantonment on 11 January 1974 and later relocated at Bhatiary in 1976. This Academy was awarded National Standard in the year 1979. BMA is the only academy for training commissioned officers and transforming a civilian into one of the finest and most professional military officers in the world. It has a rich tradition of leadership training and excellence.

Now, answer the following questions:

01 x 07 = 07

- a) What do the passages primarily discuss about?
- b) What is the chief duty of Bangladesh Army?
- c) By law, who is the defence minister of Bangladesh?
- d) Why did BBC describe Bangladesh UN Force as the "**Cream of UN Peacekeepers**"?
- e) In how many missions did the Bangladesh Armed Force participate?
- f) What were the first two missions of Bangladesh Army as UN peacekeepers?
- g) Where was BMA originally located?

2. Complete the following sentence using appropriate Modal verbs:

0.5 x 10 = 05

- a) You seem to be having trouble there. _____ I help you?
- b) I don't have enough money to buy lunch. _____ you lend me a couple of dollars?
- c) That ice is dangerously thin now. You _____ go ice-skating today.
- d) It's way past my bedtime and I'm really tired. I _____ go to bed.
- e) He _____ have committed this crime. He wasn't even in the city that night.
- f) Jamil is over two hours late already, He _____ missed the bus again.
- g) If you don't start working harder you _____ repeat the course next year.
- h) That bus is usually on time. It _____ to be here any time now.
- i) I read about your plane's near disaster. You _____ terrified!

j) Professor Rahman, we've finished our work for today. _____ we leave now, please?

3. Join any ten of the following pairs of sentences with appropriate conjunctions or relative pronouns
0.5 x 10 = 05

- a) I used torchlight. It was very dark by then.
- b) She went to see the manager personally. She had a very serious complaint to make.
- c) We had waited for you for a long time. You did not turn up at all.
- d) He was very pleased with himself. He had won first prize in the competition.
- e) You must come early. We will have time to make all the arrangements.
- f) The boys are afraid to go near that place. They have heard that it is haunted.
- g) I could not find him in his own house. I went over to Tomal's house to see if he was there.
- h) The bull rushed straight at the little boy. He quickly moved to one side.
- i) I shouted for help as loudly as I could. No one heard me.
- j) The girl did not buy that expensive pair of shoes. She liked them very much.
- k) He walked out of the room very angrily. He slammed the door hard.
- l) Shopon locked himself in my bedroom. He would not be disturbed by the children.

4. Write single sentence definitions of any five (5) of the following: 01 x 05 = 05

- a) Dictatorship (class)
- b) Liberty (negation)
- c) Plagiarism (synonym)
- d) Fridge (function)
- e) Pediatrician (class)
- f) Mentor (synonym)

5. Write a letter to your friend describing a recent farewell program of the outgoing batch in your department that you have attended. 05

6. UAP will take part in the 'International Math Olympiad 2015' to be held at Bangabandhu International Conference Centre, Agargaon. As the convener of UAP co-curriculum activities committee, write a memorandum to this effect. 05

7. The 'Dhaka International Trade Fair (DITF) 2015' took place at Sher-e-Bangla Nagar, Dhaka. As a reporter of *The Daily Star*, write a news-report on the event for publication in your newspaper. 05

8. Write a paragraph on any one of the following (word limit 200) 08

a) CE Festival

b) The Best Restaurant You Have Experienced

9. The graph below shows information from a 2008 report about consumption of energy in the USA since 1980 with projections till 2030. Describe the information available in the graph in your own words. 05

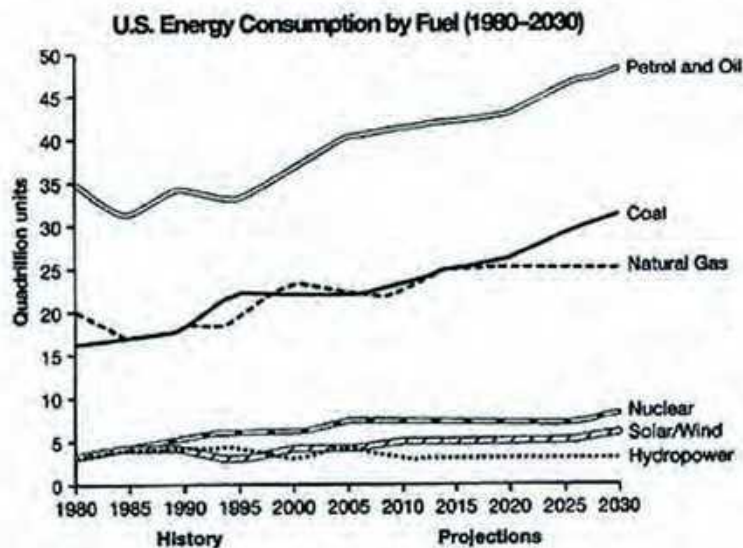

University of Asia Pacific
Department of Basic Sciences & Humanities
Semester Final Examination, Fall-2014
Program: B. Sc. Engineering (Civil)
1st year/ 2nd semester

Course Title: Mathematics II
 Time: 3 hours

Course Code: MTH 103

Credit: 3.00
 Full Marks: 150

N.B: There are two sections in the question paper namely "**SECTION A**" and "**SECTION B**". You have to answer from both sections according to the instruction mentioned in each section.

SECTION A

There are **FOUR** questions in this section. Answer any **THREE**.

1. (a) Determine the angles which the vector $\mathbf{A} = 3\mathbf{i} - 6\mathbf{j} + 2\mathbf{k}$ makes with the coordinate axes. 12
- (b) Find a unit vector parallel to the resultant of vectors $\mathbf{r}_1 = 2\mathbf{i} + 4\mathbf{j} - 5\mathbf{k}$ and $\mathbf{r}_2 = \mathbf{i} + 2\mathbf{j} + 3\mathbf{k}$. 8
- (c) Show that the addition of vectors is associative. 5
2. (a) If $\mathbf{A} = (2x^2y - x^4)\mathbf{i} + (e^{xy} - y\sin x)\mathbf{j} + (x^2\cos y)\mathbf{k}$, find 18

$$\frac{\partial A}{\partial x}, \frac{\partial A}{\partial y}, \frac{\partial^2 A}{\partial x^2}, \frac{\partial^2 A}{\partial y^2}, \frac{\partial^2 A}{\partial x \partial y}, \frac{\partial^2 A}{\partial y \partial x}$$
- (b) Find the unit tangent vector to any point on the curve $x = t^2 + 1, y = 4t - 3, z = 2t^2 - 6t$. Also determine the unit tangent at the point where $t = 2$. 7
3. (a) If $\mathbf{A} = A_1\mathbf{i} + A_2\mathbf{j} + A_3\mathbf{k}$; $\mathbf{B} = B_1\mathbf{i} + B_2\mathbf{j} + B_3\mathbf{k}$ and $\mathbf{C} = C_1\mathbf{i} + C_2\mathbf{j} + C_3\mathbf{k}$ then prove that 7

$$\mathbf{A} \cdot (\mathbf{B} \times \mathbf{C}) = \mathbf{C} \cdot (\mathbf{A} \times \mathbf{B})$$
- (b) If $\mathbf{A} = 3\mathbf{i} - \mathbf{j} + 2\mathbf{k}$; $\mathbf{B} = 2\mathbf{i} + \mathbf{j} - \mathbf{k}$ and $\mathbf{C} = \mathbf{i} - 2\mathbf{j} + 2\mathbf{k}$ find $(\mathbf{A} \times \mathbf{B}) \times \mathbf{C}$. 6
- (c) If $\mathbf{A} = \sin u \mathbf{i} + \cos u \mathbf{j} + u \mathbf{k}$; $\mathbf{B} = \cos u \mathbf{i} - \sin u \mathbf{j} - 3\mathbf{k}$ and $\mathbf{C} = 2\mathbf{i} + 3\mathbf{j} - \mathbf{k}$ find $(\mathbf{A} \times (\mathbf{B} \times \mathbf{C}))$ at $u = 0$. 12

4. (a) Define Gradient, Divergence and Curl. 9
- (b) i. Find $\text{grad } \phi$ if $\phi = \frac{1}{r}$. 16
- ii. Prove $\nabla \times (\nabla \times \mathbf{A}) = -\nabla^2 \mathbf{A} + \nabla(\nabla \cdot \mathbf{A})$.

SECTION B

There are FOUR questions in this section. Answer any THREE.

5. (a) To find the condition that the general equation of the second degree $ax^2 + 2hxy + by^2 + 2gx + 2fy + c = 0$ may represent a pair of straight lines and also find the value of their point of intersection. 17
- (b) Show that the equation $2x^2 - 2xy + x + 2y - 3 = 0$ represents a pair of straight lines; also find their point of intersection and the angle between them. 8
6. (a) Determine the angle between two lines whose direction cosines are given by the equations relations $l + m + n = 0$ and $l^2 + m^2 - n^2 = 0$. 10
- (b) Find the equation of the plane through $(2, -1, 0)$ and $(3, -4, 5)$ and perpendicular to the plane $2x + y - z + 6 = 0$. 8
- (c) Compute the projection of the join of points $(-1, -1, 3)$ and $(2, 0, 1)$ on the line through the points $(-7, 5, 3)$ and $(2, 6, 8)$. 7
7. (a) Define Direction Cosines of a line. 5
- (b) If P & Q are $(1, -5, 7)$ and $(-3, 6, -2)$ and O be the origin, find the direction cosines of OP, OQ and PQ. Also find the angle POQ. 10
- (c) Find the equation of the plane through the points $(2, 1, -3)$, $(3, -1, 4)$, $(7, 5, 6)$. 10
8. (a) Find for what value of δ the equation $x^2 - 4xy - y^2 + 6x + 8y + \delta = 0$ represents a pair of straight lines. 8
- (b) Find the equation of the plane through the line of intersection of the planes $x + 2y + 3z - 4 = 0$ and $2x + y - z + 5 = 0$ that is perpendicular to the plane $5x + 3y + 6z + 8 = 0$. 8
- (c) Find the equation of the plane through the point $(4, 0, 1)$ and parallel to the plane $4x + 3y - 12z + 6 = 0$. 9

University of Asia Pacific
Department of Civil Engineering
Final Examination Fall 2014
Program: B.Sc. Engineering (Civil)

Course Title: Engineering Materials
Time: 3 Hours

Course Code: CE 201 (B)
Full Marks: 150

There are **EIGHT** questions. Answer any **SIX** questions including **Question #1** and **Question# 2**.
QUESTIONS 1 and 2 are compulsory.

1. Concrete mix design is required for slabs of a building project on the following data: (40)

Volume ratio of sand to total aggregate = 0.40
Air Content = 2% (air entraining admixture is not used)
Specific gravity of cement 2.9 (CEM II B-M)
Specific gravity of coarse aggregate (SSD) = 2.6
Specific gravity of fine aggregate (SSD) = 2.5
Design compressive strength (28 days) = 4000 Psi
Minimum required slump = 100 mm
Maximum aggregate size = 3/4 inch, Aggregate type = Stone chips
Dosage of superplasticizer = 5 ml/kg of cement if w/c is less than 0.45

The following graphs are provided:

- Variation of compressive strength (28 day with w/c)
- Variation of cement content with compressive strength (28 day) for different aggregate size and slump value.

Calculate the following:

- (i) Calculate unit contents based on the given data.
- (ii) Calculate the unit weight of the proposed mix.
- (iii) Prepare a mixture proportion table of the proposed mix. Typical form of mixture proportion table is attached.
- (iv) Calculate the volume ratio of the mix. Assume unit weights of cement, sand (SSD) and coarse aggregate (SSD) with void are 1400 kg/m³, 1550 kg/m³ and 1200 kg/m³ respectively
- (v) Estimate the materials in weight and volume (cement, water, sand, and coarse aggregate) required to make a slab of 20 feet length, 18 feet width, and 6 inch depth.
- (vi) Why you need to consider the compaction factor in mix design? Calculate the compaction factor of the mix.
- (vii) What consideration will you make if the temperature is very high during concrete mixing?
- (viii) Explain the advantages and disadvantages of volumetric and weight based mix design.

2. For a culvert construction project, the recommended FM is 2.7 for sand and 6.8 for brick chips. The samples were collected from nearby market and tested in Concrete laboratory of University of Asia Pacific (UAP) for sieve analysis. The Sieve analysis data are given below: (22)

ASTM Sieve	Amount Retained (g)	
	Sand	Brick Chips
3"	0	0
1.5"	0	0
1.0"	0	0
3/4"	0	300
1/2"	0	2500
3/8"	0	1700
# 4	0	400
# 8	0	0
# 12	80	0
# 16	140	0
# 30	10	0
# 40	50	0
# 50	90	0
# 100	40	0
# 200	45	0
Pan	45	100

- (i) Calculate the FM of the sample.
(ii) Draw the grading curve of the samples,
(iii) Discuss the possible ways to improve the FM to the recommended value.
(iv) Comment on the samples based on the sieve analysis data and grading curves.
3. (a) Draw typical stress-strain curves of concrete, steel reinforcement, rubber, CFRP, and glass. (2.5)
(b) Write short note on: (i) Creep, (ii) Relaxation, (iii) Ductility. (3)
(c) Explain the strength development process of brick during burning. How bricks are classified in Bangladesh? (4)
(d) Distinguish between clamp burning and kiln burning of bricks. (2)
(e) What are the benefits of brick aggregate over stone aggregate in concrete construction works? (2.5)
(f) Explain different field tests that are commonly used to check the quality of bricks in the construction site. (4)
(g) What is efflorescence? What will happen if the bricks used in wall have significant efflorescence? (4)
4. (a) What do you mean by hydration of cement? Write the hydration reactions of cement and discuss the morphology of the hydration product. (5)

- (b) Write short notes on CEM I, CEM II A-M, CEM II B-M, CEM II A-L, and CEM II B-S cement as per BDS EN 197-1:2003. (5)
- (c) Define normal consistency, initial setting, and final setting time of cement. (3)
- (d) Draw the flow diagram of cement manufacturing process. Also, draw a schematic diagram of rotary kiln (used in cement manufacturing) and discuss the physical and chemical changes that happen in the different zones of the kiln. (7)
- (e) How will you consider ignition loss in cement? (2)
5. (a) Discuss the following factors associated with the strength of concrete: (7.5)
- (i) Cement content
 - (ii) Cement type
 - (iii) Aggregate gradation
 - (iv) Cement fineness
 - (v) Curing
- (b) Define workability of concrete? How it is measured? (3)
- (c) Write short notes on the followings: (7.5)
- (i) Recycled concrete
 - (ii) Pervious concrete
 - (iii) Self-compacting concrete
 - (iv) Fiber reinforced concrete
 - (v) High performance concrete
- (d) What is plaster? Discuss the uses of plaster in civil engineering. (4)
6. (a) Distinguish between segregation and bleeding. (3)
- (b) Write a short note about: (i) Honey comb, (b) Laitance. (3)
- (c) "Compressive strength of cube is higher than cylinder compressive strength for same mix batch"-Why? (3)
- (d) Discuss the following factors associated with the workability of concrete: (6)
- (i) Cement type
 - (ii) Fineness of cement
 - (iii) Fine aggregate to total aggregate ratio
 - (iv) Shape of aggregate
- (e) Explain different methods of curing of concrete. (3)
- (f) What is shrinkage? Explain different types of shrinkage of concrete. (4)
7. (a) Explain the seawater attack (chloride, sulphate, and CO₂) of concrete with chemical reactions. (8)
- (b) "W/C ratio is the key parameter related to strength and durability of concrete"-explain briefly. (3)
- (c) How is corrosion cell formed over the steel bar inside concrete? Explain with anodic and cathodic reactions. (4)
- (d) What is carbonation? What will happen if concrete is carbonated? (4)
- (e) Write a short note about electroplating. (3)

8. (a) What are the uses of rubber in civil engineering construction? (3)
- (b) Draw typical cross-section of a exogenous tree. Write the objectives of seasoning of timber. (5)
- (c) Explain natural and artificial defects in a tree. Show sketch where necessary. (8)
- (d) Determine the time to start corrosion of steel inside concrete in a beam with clear cover =25 mm. [Given, Coefficient of carbonation= 3.75] (3)
- (e) What is Ferro-cement? Explain the use of ferrocement in civil engineering works. (3)

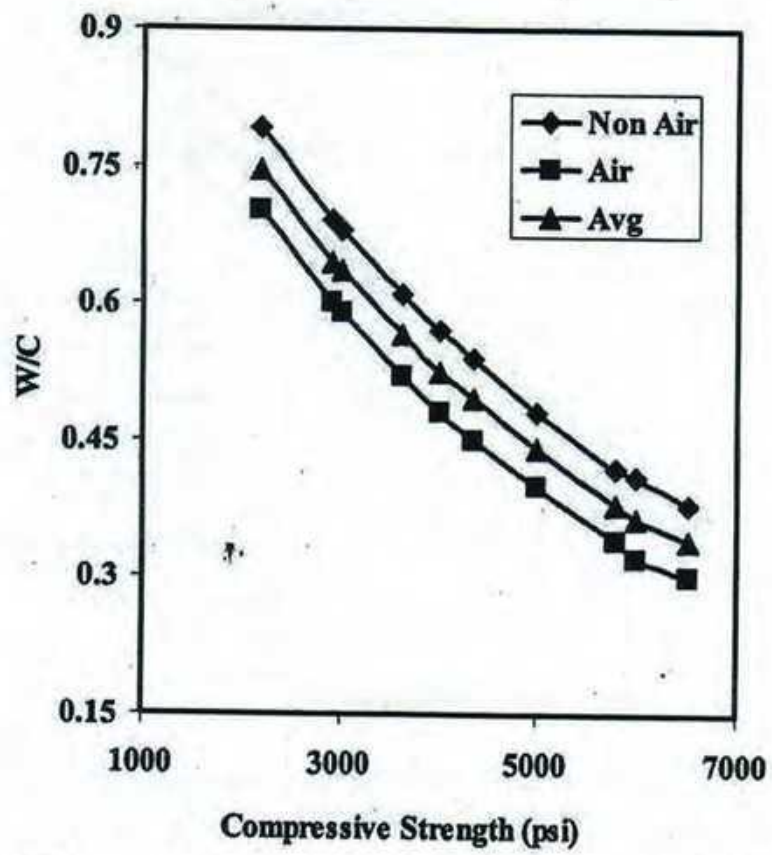

Fig. W/C versus Compressive Strength (aggregate type = stone chips)

University of Asia Pacific
Department of Civil Engineering
Final Examination Fall 2014
Program: B.Sc Engineering (Civil)

Course Title: Mechanics of Solids I
 Time: 3:00 hours

Course Code: CE 211
 Full Marks: 10 x 10 = 100

*Answer any 10 (Ten) of the following 14 Questions
 The symbols have their usual meanings.*

1. Draw SFD and BMD for the beam with loading shown below. *B* is an internal hinge.

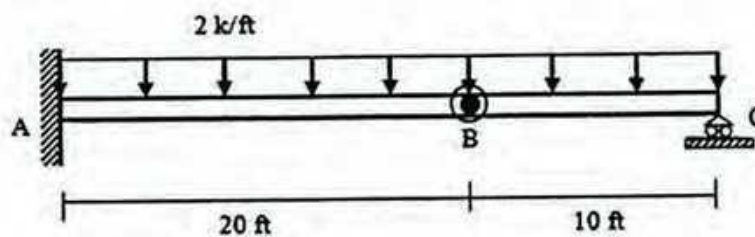

2. Derive the complete equations of Shear Force and Bending Moment of the beam shown below.

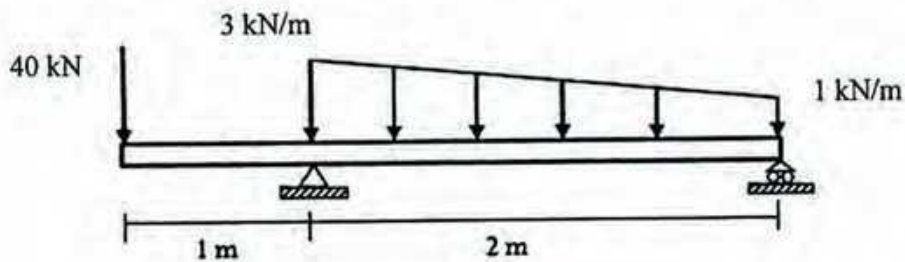

3. Use singularity functions to write equations of SF and BM of the beam loaded as shown below.

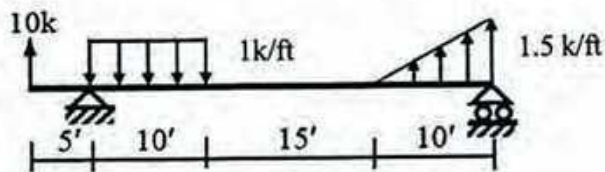

4. Draw AFD, SFD and BMD for the beam with loading shown below. *B* is a internal hinge.

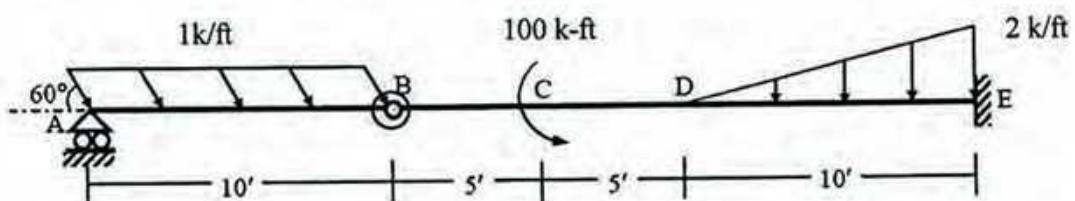

5. Calculate the shearing stress in the rivets and the maximum tearing and bearing stresses in the plates at joint B of the structural member ABC loaded as shown below.

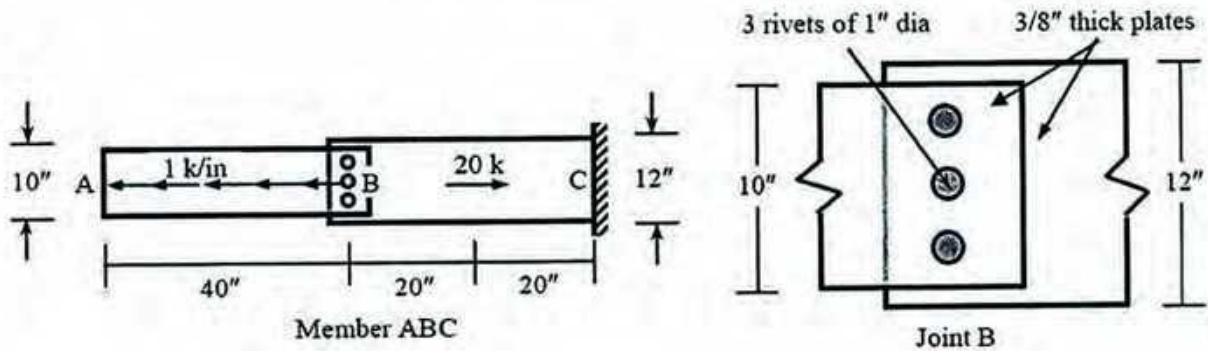

6. A 4 x 4 x 3/8 in. angle, which is to be welded to a gusset plate, carries a load of 80 kips applied along its centroidal axis. Assuming the allowable shearing stress through the throat of each weld is 21 ksi and maximum weld size of 5/16 in., determine the minimum length of welds along 3 sides (a, b, and c) of the angle.

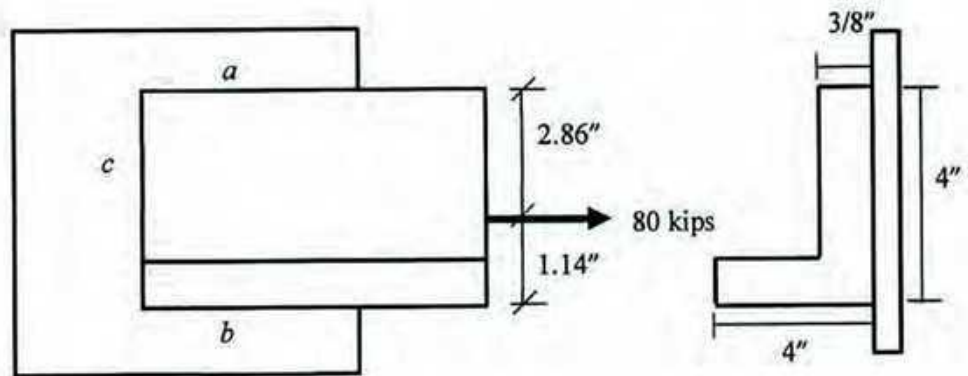

7. A bronze bar is fastened between a steel bar and aluminum bar as shown below. Axial loads are applied at the positions indicated. Determine the largest value of P that will cause no more than 3.0 mm overall deformation or the following stresses: 140 MPa in steel, 120 MPa in bronze and 80 MPa in the aluminum. Use $E_{st} = 200$ GPa, $E_{al} = 70$ GPa and $E_b = 83$ GPa.

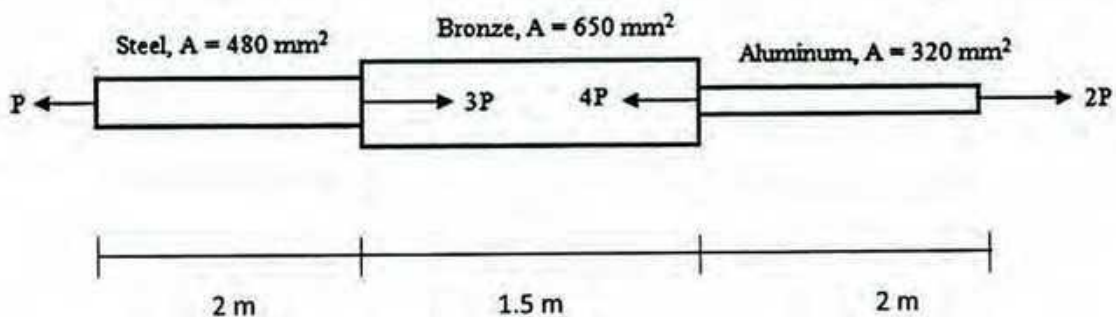

8. As shown below, a rigid bar with negligible mass is pinned at O and attached to two vertical rods. Assuming that the rods were initially stress-free, what maximum load P can be applied without exceeding stresses of 150 MPa in the steel rod and 70 MPa in the bronze rod?

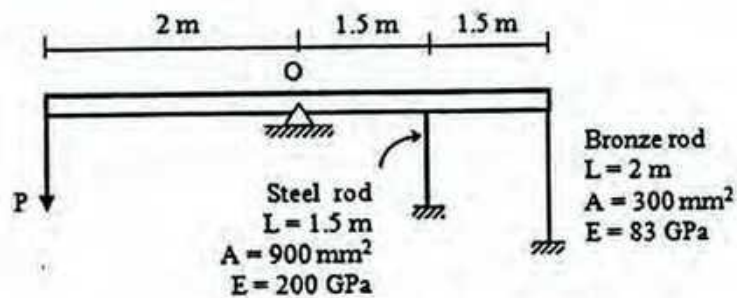

9. A cylindrical pressure vessel is fabricated from steel plate that has a thickness of 20 mm. The diameter of the pressure vessel is 450 mm and its length is 2.0 m. Determine the maximum internal pressure that can be applied if the longitudinal stress is limited to 140 MPa and circumferential stress is limited to 60 MPa.

10. An inverted small steel T beam is supported at A and B as shown below. What is the value of P if a strain gage attached at x point measures 0.0002 mm/mm when the load is applied. All dimensions are in mm. $E = 200 \text{ GPa}$. Units are in mm.

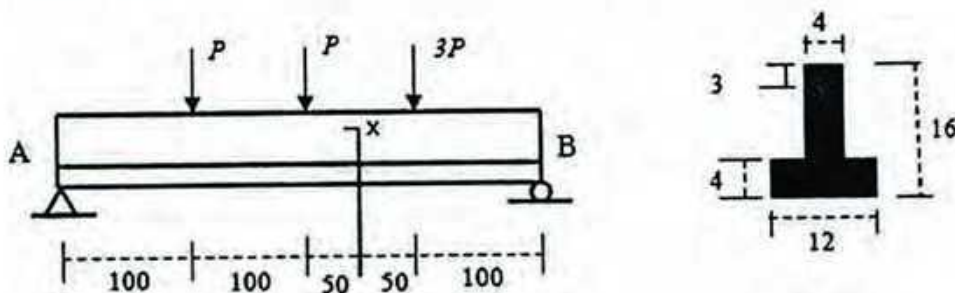

11. Consider a composite beam of the cross-sectional dimensions shown below. The upper 150x250 mm part is aluminum with the lower 10x150 mm strap is steel. If the beam is subjected to a bending moment of 30 kN-m about horizontal axis, what are the maximum stresses in the steel and aluminum?

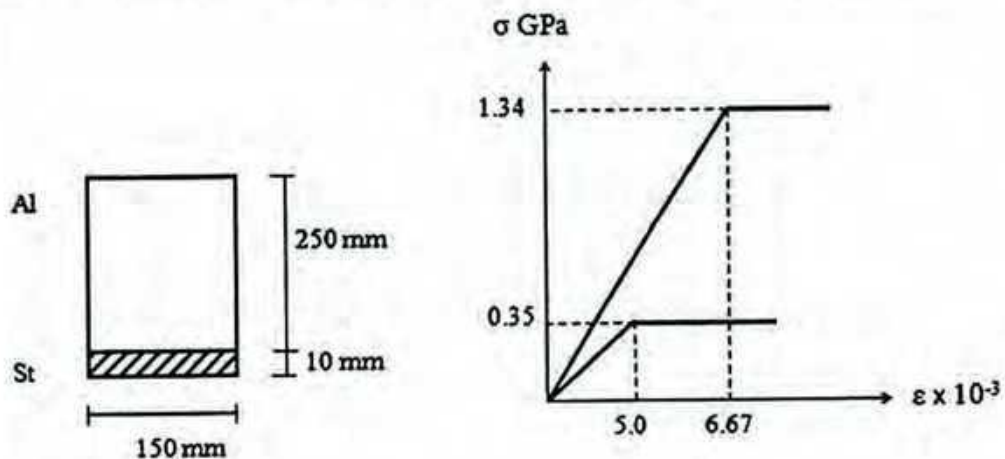

12. Determine the maximum stress in the concrete and the steel for a reinforced concrete beam with the section shown below if it is subjected to a positive bending moment of 50 kip-ft. The reinforcement consists of four #9 steel bars. Assume cracked section and $n = 15$.

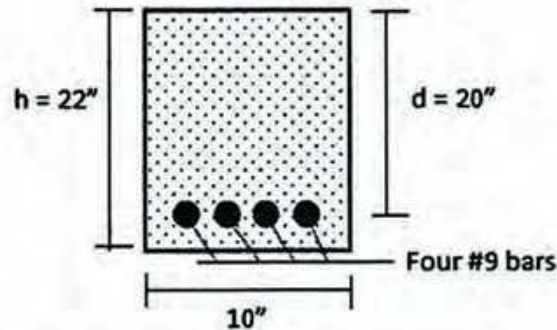

13. A simple beam on 6-m span carries a load of 3 kN/m including its own weight. Specify the spacing of 10-mm screw (as shown) necessary to fasten the parts together. Assume that allowable shear capacity for 10-mm screw is 2 kN.

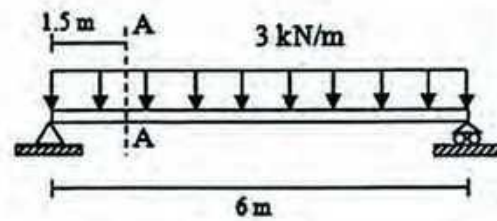
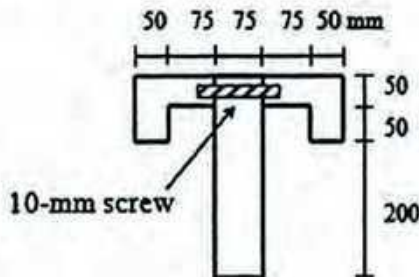

14. A beam having the cross section with dimension shown below, transmits a vertical shear $V = 7$ kip. Determine the shear stress at section a-a, b-b and c-c. Section b-b is at neutral axis.

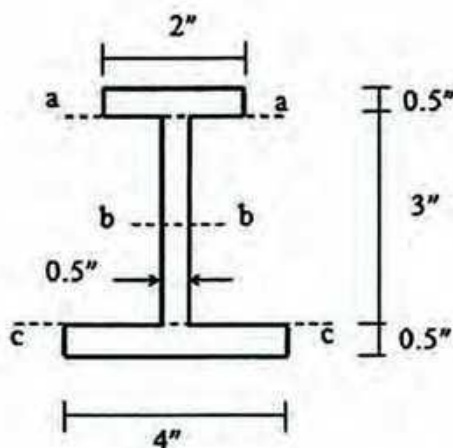

University of Asia Pacific
Department of Civil Engineering
Semester Final Examination, Fall-2014
Program: B. Sc Engineering (2nd Year / 1st Semester)

Course Title: Basic Electrical Engineering Course No. ECE (CE) 201 Credits: 3.00
 Time: 3.00 Hours. Full Marks: 150

There are **Eight** Questions. Answer any **Six**. Figures in the right margin indicate marks.

1. (a) Determine the Norton equivalent of the following circuit as seen from terminals a-b. Use the equivalent to find I_o . (13)

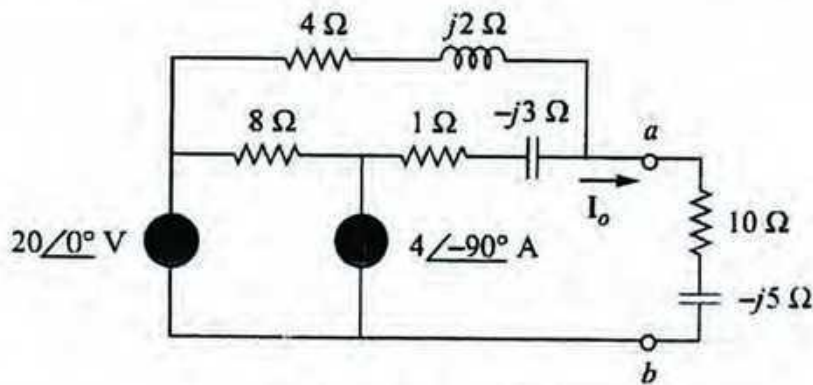

Circuit diagram for question 1(a)

- (b) State and prove Maximum Power Transfer Theorem. (12)
2. (a) Find i_x in the following circuit using nodal analysis. (12)

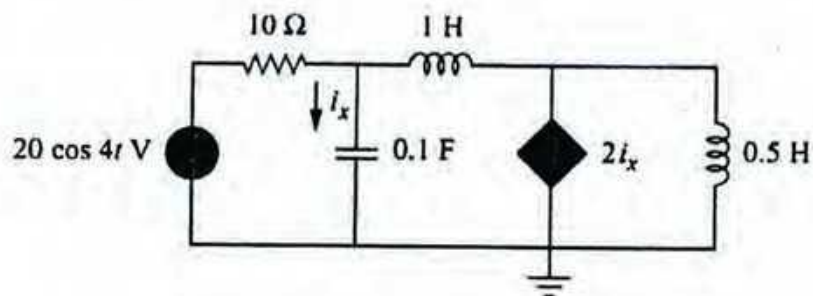

Circuit diagram for question 2(a)

(b) Find I_o in the following circuit using mesh analysis.

(13)

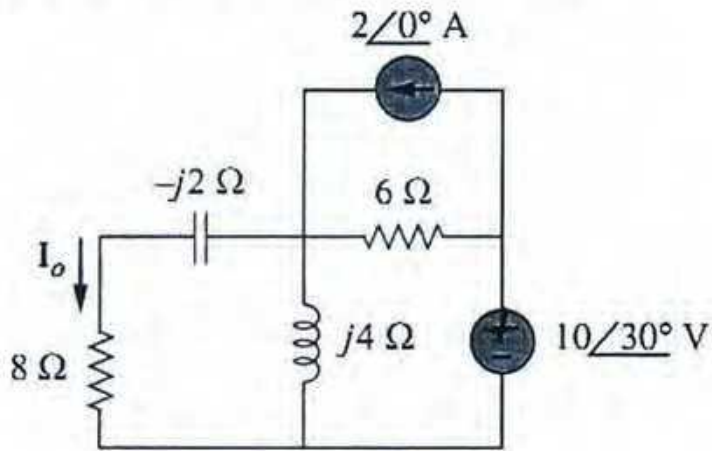

Circuit diagram for question 2(b)

3. (a) Determine the secondary current I_2 for the transformer of the following figure if the resultant clockwise flux in the core is 2.5×10^{-5} Wb. (13)

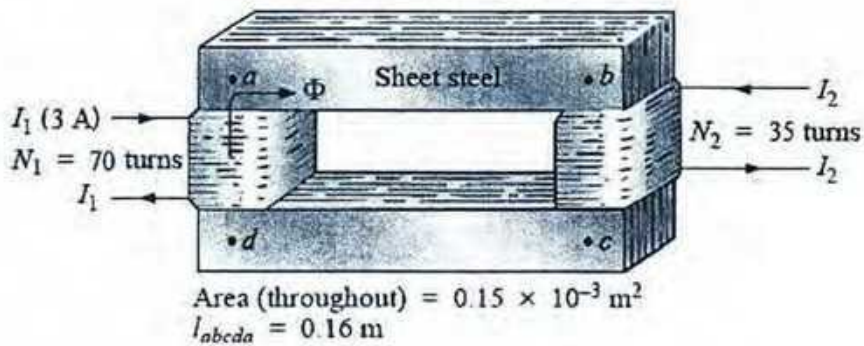

Circuit diagram for question 3(a)

Required B-H table:

B (T)	0.1	0.167	0.2	0.25
H (A-t/m)	20	30	40	45

(b) Given $v_1=20\sin(\omega t + 60^\circ)$ and $v_2=60\cos(\omega t - 10^\circ)$. Determine the phase angle between the two sinusoids and which one lags the other?

If voltage $v=6\cos(100t-30^\circ)$ is applied to $50\mu\text{F}$ capacitor, calculate the current through the capacitor. (8+5)

6. (a) For the following circuit, find the voltages across each capacitor. (13)

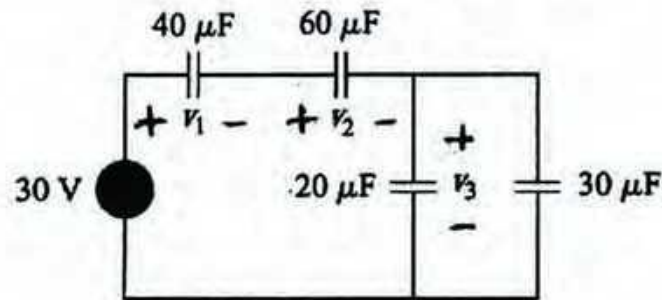

Circuit diagram for question 6(a)

(b) In the following circuit $i_1(t)=0.6e^{-2t}$. If $i(0)=1.4\text{A}$, find (i) $i_2(0)$ (ii) $i_2(t)$ (iii) $i(t)$ (iv) $v(t)$ (v) $v_1(t)$ (vi) $v_2(t)$ (12)

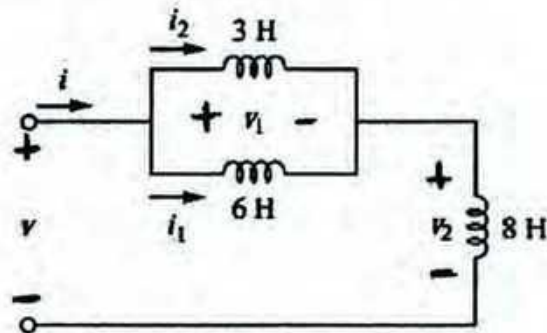

Circuit diagram for question 6(b)

7. (a) Show that the voltage current relationship in frequency domain for inductor is $V=j\omega LI$ when assume the current through the inductor is $i=I_m \cos(\omega t + \varphi)$ (13)

(b) Prove that for the sinusoid $i(t)=I_m \cos \omega t$, the rms or effective value is $I_{\text{rms}}=I_m/\sqrt{2}$ (12)

(a) The waveform shown in the following figure is a half wave rectified sine wave. Find the rms value and average power dissipated in 10Ω resistor. (13)

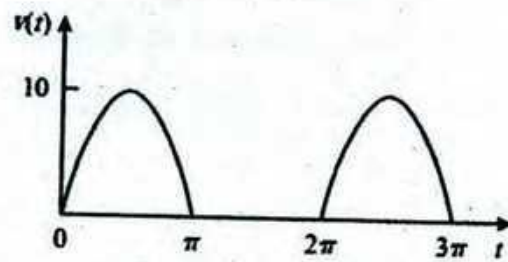

Circuit diagram for question 8(a)

(b) A series connected load draws a current $i(t) = 4\cos(100\pi t + 10^\circ)$ A when applied voltage is $v(t) = 120\cos(100\pi t - 20^\circ)$. Find the apparent power and power factor of the load. Determine the element values that form the series connected load. (12)

- (b) Calculate V_x in the following circuit using the method of source transformation. (12)

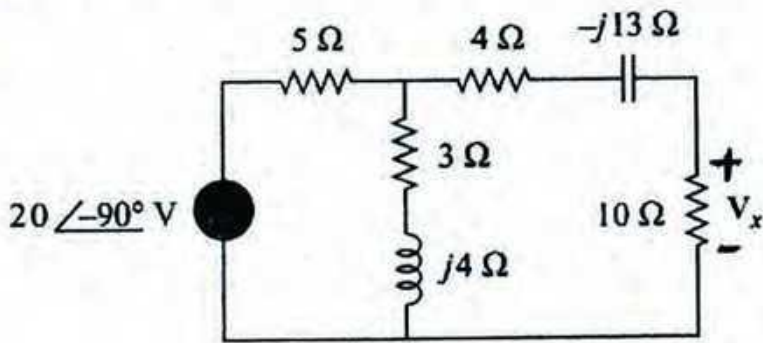

Circuit diagram for question 3(b)

4. (a) Use the superposition theorem to find I_o in the following circuit. (18)

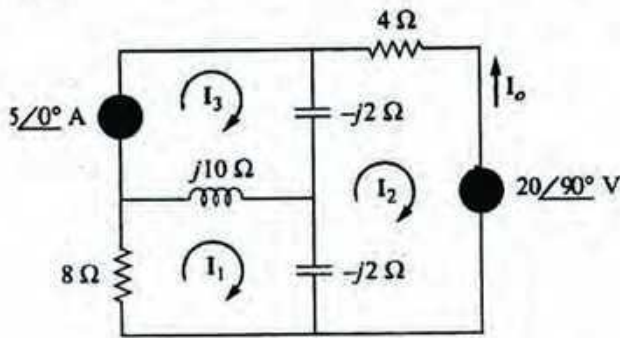

Circuit diagram for question 4(a)

- (b) Show that the equivalent capacitance of N parallel-connected capacitors is the sum of individual capacitances. (7)

5. (a) Calculate V_o in the following circuit. (12)

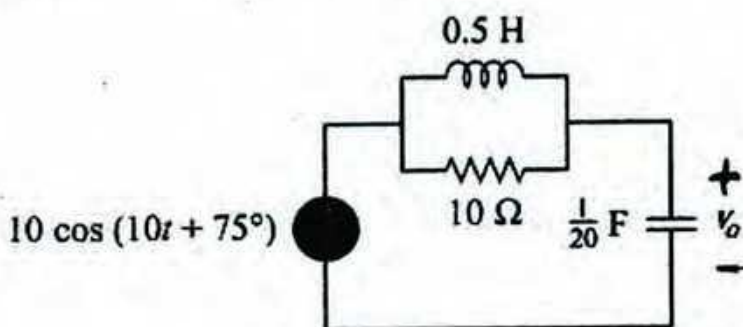

Circuit diagram for question 5(a)

University of Asia Pacific
Department of Basic Sciences and Humanities
Semester Final Examination, Fall 2014
Programme: B. Sc. Engineering (Civil)
(2nd Year 1st Semester)

Course Title: Bangladesh Studies: Society and Culture

Course Code: HSS 211(a)

Credit: 2.00

Time: 2 Hours

Full Marks: 100

There are SIX questions. Answer any FOUR. (4x25)

Figures in the right margin indicate marks.

1. Define social stratification. What are the characteristics of social stratification? "No society is classless or un-stratified" describe the different types of social stratification?
8+7+10
2. What is the difference between crime and deviance? What are the different schools of crime? Briefly describe Sutherland's theory.
5+5+15
3. Define social mobility. What are the vertical, horizontal, intergenerational and intragenerational social mobility? What are the causes of social mobility in Bangladesh?
7+8+10
4. What is economic institution? What are the differences between food collecting and food producing economy? What are the characteristics of horticultural, agricultural and industrial societies?
5+5+15
5. Define culture and civilization. What are the characteristics of culture? "Culture is what we are and civilization is what we use"-- justify the statement.
5+10+10
6. What is political institution? What are the functions of rural and urban local government in Bangladesh?
5+10+10

University of Asia Pacific
Department of Basic Sciences and Humanities
Semester Final Examination, Fall 2014
Program: B.Sc. Engineering (Civil)
2nd year 1st semester

Course Title: Bangladesh Studies: History
Credit: 2.00

Course Code: HSS 211(b)

Total Time: 2 Hours

Full Marks: 100

Answer ANY FOUR (4 x 25)

1. What was *permanent settlement*? Why did Lord Cornwallis introduce it in Bengal?
2. How did *Pandit Ishwar Chandra Vidyasagar* contribute to the society?
3. Why did Lord Curzon *Partition Bengal* in 1905? How did the Muslims and Hindus react?
4. Describe the background of *Lahore Resolution*. How did the term '*States*' replace by '*State*'?
5. Describe the first phase and significance of *Language Movement*.
6. Explain the *Six Points* of Awami League.

UNIVERSITY OF ASIA PACIFIC
Department of Basic Sciences & Humanities
Final Examination Fall 2014
Program: B. Sc. Engineering (Civil)
2nd year/ 1st semester

Course Title: Math III
 Time: 3 (Three) hours

Credit: 3.00

Course Code: MTH 201
 Full Marks: 150

Section- A

Answer any 3 (Three) of the following questions:

1. (a) Define basis and dimension of a vector space. Write down the standard basis and dimension of \mathbb{R}^4 , P_4 and $M_{4 \times 4}$. 12
- (b) Let W be the subspace of \mathbb{R}^5 spanned by the vectors $(1, -2, 0, 0, 3)$, $(2, -5, -3, -2, 6)$, $(0, 5, 15, 10, 0)$ and $(2, 6, 18, 8, 6)$. Find a basis and dimension of W . 13
2. (a) Let S and T be the linear operators of \mathbb{R}^2 into \mathbb{R}^2 defined by
 $S(u, v) = (3u + 2v, -6u + v)$ and $T(u, v) = (2u + v, u - v)$.
 Find (i) $(ST)(u, v)$ (ii) $S^2(u, v)$ 10
- (b) State dimension theorem. Find the rank and nullity of the matrix
 $A = \begin{pmatrix} 1 & 3 & 1 & -2 & -3 \\ 1 & 4 & 3 & -1 & -4 \\ 2 & 3 & -4 & -7 & -3 \\ 3 & 8 & 1 & -7 & -8 \end{pmatrix}$ and verify the dimension theorem. 15
3. (a) Define the kernel and the image of a linear transformation. Let $T: \mathbb{R}^4 \rightarrow \mathbb{R}^3$ be a linear transformation defined by
 $T(x, y, s, t) = (x - y + s + t, x + 2s - t, x + y + 3s - 3t)$.
 Find a basis and the dimension of the kernel of T and the image of T . 15
- (b) Determine a basis and the dimension for the solution space of the homogeneous system of equations 10
- $$\begin{aligned} x_1 + x_2 - x_3 &= 0 \\ -2x_1 - x_2 + 2x_3 &= 0 \\ -x_1 + x_3 &= 0 \end{aligned}$$
4. (a) Define eigenvalues and eigenvectors and write the characteristic equation of a matrix. Determine the eigenvalues and associated eigenvectors of the matrix 15

$$A = \begin{pmatrix} 1 & 2 & 2 \\ 1 & 2 & -1 \\ -1 & 1 & 4 \end{pmatrix}$$

- (b) State Cayley-Hamilton theorem and verify this theorem for the matrix $A = \begin{pmatrix} 1 & 4 \\ 9 & 1 \end{pmatrix}$ also using the theorem find A^{-1} . 10

Section- B

Answer any 3 (Three) of the following questions:

5. (a) For the following frequency distribution table calculate mean, median and mode. 10

Weekly rent (in \$)	200-400	400-600	600-800	800-1000	1000-1200	1200-1400
No. of persons paying the rent	6	9	11	14	20	15

- (b) An incomplete distribution is given below:

Variable	10-20	20-30	30-40	40-50	50-60	60-70	70-80
Frequency	12	30	?	65	?	25	18

If the total frequency is 229 and median value is 46 then using the median formula, fill up the missing frequencies and calculate the mean of the completed table. 15

6. (a) What is variance and standard deviation? Compute the standard deviation for the following frequency distribution. 13

Mass in Kg	60-62	63-65	66-68	69-71	72-74
No. of students	5	18	42	27	8

- (b) From the following data of age of employees, calculate coefficient of skewness and comments on the result: 12

Age below (yrs)	25	30	35	40	45	50	55
No. of employees	8	20	40	65	80	92	100

7. (a) The following table gives the age and blood pressure of 10 patients: 15

Age (yrs)	56	42	36	47	49	42	60	72	63	55
Pressure	147	125	118	128	145	140	155	160	149	150

Compute the coefficient of correlation between the age and blood pressure.

- (b) A student takes his examination in four subjects A, B, C and D. He estimates his chances of passing in A as $\frac{4}{5}$, in B as $\frac{3}{4}$, in C as $\frac{5}{6}$ and in D as $\frac{2}{3}$. To qualify, he must pass in B and at least two other subjects. What is the probability that he qualifies? 10
8. (a) The probability that a contractor will get a plumbing contract is $\frac{2}{3}$ and the probability that he will not get an electric contract is $\frac{4}{9}$. If the probability of getting at least one contract is $\frac{3}{5}$, what is the probability that he will get both? 5
- (b) What do you know about binomial distribution and Poisson distribution? The overall percentage of failures in a certain examination is 20. If six candidates appear in the examination, what is the probability that at least five pass the examination? 10

- (c) A die is thrown 8 times and it is required to find the probability that 3 will show
(i) Exactly 2 times (ii) At least seven times (iii) At least once.

10

The End

University of Asia Pacific
Department of Civil Engineering
Final Examination (Fall 2014)
Program: B.Sc. Engg(3rd year 1st semester)

Course Title: Principles of Accounting
Time : 2 hrs.

Course: ACN 301

Credit Hours: 2.0
Full marks : 50

(Answer any four from the followings)

Q.1. Superior Development Company Ltd. has the following cost and expense data for the year ended December 31, 2014.

Raw Material, 1/1/14	\$30,000	Factory Insurance	\$14,000
Raw Material, 31/12/14	20,000	Factory –Property tax	6,000
Finished Goods, 1/1/14	110,000	Raw material purchases	205,000
Finished Goods, 31/12/14	120,000	Administrative Expense	300,000
Work in process, 1/1/14	80,000	Sales (Net)	1,500,000
Work in process, 31/12/14	50,000	Utilities, Factory	65,000
Direct labor	350,000	Delivery Expense	100,000
Indirect labor	90,000	Sales commission	150,000
Indirect material	15,000	Machine rent, Factory	40,000
Factory Manager's Salary	35,000	Depreciation, Factory Building	24,000

INSTRUCTION:

- A. Prepare a cost of goods manufactured schedule for Superior Development Company Ltd. for the year ended, December 31, 2014. (6.5)**
- B. Prepare an income statement for the year ended, December 31, 2014. (6.0)**

Q.2. On May 31, 2012, Sabre Company had a cash balance per books of \$6,781.50. The bankstatement from New York State Bank on that date showed a balance of \$6,404.60. A comparison of the statement with the cash account revealed the following facts.

- a. The statement included a debit memo of \$40 for the printing of additional company checks.
- b. Cash sales of \$836.15 on May 12 were deposited in the bank. The cash receipts journal entry and the deposit slip were incorrectly made for \$886.15. The bank credited Sabre Company for the correct amount.
- c. Outstanding checks at May 31 totaled \$576.25. Deposits in transit were \$1,916.15.
- d. On May 18, the company issued check No. 1181 for \$685 to Carol Stills on account. The check, which cleared the bank in May, was incorrectly journalized and posted by Sabre Company for \$658.
- e. A \$2,500 note receivable was collected by the bank for Sabre Company on May 31 plus \$80 interest. The bank charged a collection fee of \$20. No interest has been accrued on the note.
- f. Included with the cancelled checks was a check issued by Rapier Company to Tom Lujak for \$800 that was incorrectly charged to Sabre Company by the bank.
- g. On May 31, the bank statement showed an NSF charge of \$680 for a check issued by Jo Bennett, a customer, to Sabre Company on account.

INSTRUCTION:

Prepare the bank reconciliation at May 31, 2012.

(12.5)

Q.3.a. Carver Construction Company is under contract to build a condominium at a contract price of \$4,000,000. The building will take 18 months to complete at an estimated cost of \$2,800,000. Construction began in November 2011, and was finished in April 2013. Actual construction costs incurred in each year were: 2011, \$280,000; 2012, \$1820,000; and 2013, \$700,000.

PTO

INSTRUCTION:

Compute the gross profit to be recognized in each year keeping in mind revenue recognition and matching principles. (6.5)

Q.3.b. The controller of Loran Industries has collected the following monthly expense data for use in analyzing the cost behavior of maintenance costs.

<u>Month</u>	<u>Total Maintenance Costs</u>	<u>Total Machine Hours</u>
January	\$2,400	300
February	3,000	400
March	3,600	600
April	4,500	790
May	3,200	500
June	4,900	800

INSTRUCTION:

Determine the fixed and variable cost components using the high-low method and write down the cost function for the maintenance cost. (6.0)

Q.4. Wales Company sells small commercial spaces of a mall that sell for \$3000 each. Each shop has similar floor space and facility. For the coming year, management expects fixed costs to total \$200,000 and variable costs to be \$2000 per unit.

- (a) Compute the break-even point in dollars.
- (b) Compute the margin of safety percentage assuming actual sales are \$750,000.
- (c) Compute the sales required in units to earn net income of \$120,000.
- (d) Due to tough market competition management at Wales is thinking of reducing the selling price to \$2900 per commercial space. If the selling price is reduced, compute the sales required in units to earn the net income of \$12,000. (3+3+3+3.5)

Q.5. DDC Ltd. supervises construction of an extension to a residential building. The standard cost per unit of per square feet is as follows:

Direct materials 2 pounds at \$5.00 per pound	\$10.00
Direct labor 2 hours at \$12.00 per hour	24.00
Variable manufacturing overhead	12.00
Fixed manufacturing overhead	<u>6.00</u>
Total standard cost per unit	<u>\$52.00</u>

Actual costs for November in producing 7,700 square feet were as follows:

Direct materials (15,000 pounds)	\$ 72,000
Direct labor (14,900 hours)	183,270
Variable overhead	88,990
Fixed overhead	<u>44,000</u>
Total manufacturing costs	<u>\$388,260</u>

INSTRUCTIONS:

Compute the followings and make comments:

- (1) Material price variance, where $MPV = AQ(AP-SP)$
- (2) Material quantity variance, where $MQV = SP(AQ-SQ)$
- (3) Labor price variance, where $LPV = AH(AR-SR)$
- (4) Labor quantity variance, where $LQV = SR(AH-SH)$

(12.5)

Q.6.a. Armando Company is considering a capital investment project of \$150,000 in its construction facilities. The new machinery bought for the project is expected to have a useful life of 5 years with no salvage value. Depreciation is by the straight-line method. During the life of the investment, annual net income and cash inflows are expected to be \$18,000 and \$48,000, respectively. Armando has a 12% cost of capital rate, which is the minimum acceptable rate of return on the investment.

INSTRUCTION:

Using the discounted cash flow technique, compute the net present value. Should Armando accept the project?

(5.5)

Q.6.b. Gabriela Herzog, a recent graduate of Rolling's architecture program, evaluated the operating performance of real estate-Emaar's six divisions. Gabriela made the following presentation to Emaar board of directors and suggested the Graphics Division be eliminated. "If Graphics Division is eliminated," she said, "our total profits would increase by \$16,870."

	<u>The Other Five Divisions</u>	<u>Graphics Division</u>	<u>Total</u>
Sales	\$1,664,200	\$ 98,200	\$1,762,400
Cost of goods sold	978,520	76,470	1,054,990
Gross profit	685,680	21,730	707,410
Operating expenses	527,940	38,600	566,540
Net income	<u>\$ 157,740</u>	<u>\$(16,870)</u>	<u>\$ 140,870</u>

In the Graphics Division, cost of goods sold is \$56,000 variable and \$20,470 fixed, and operating expenses are \$12,000 variable and \$26,600 fixed. None of the Graphics Division's fixed costs will be eliminated if the division is discontinued.

INSTRUCTION:

Is Gaby right about eliminating the Graphics Division? Prepare a schedule to support your answer.

(7.0)

TABLE 2 Present Value of \$1

$$PV = \frac{\$1}{(1 + i)^n}$$

n/	1.0%	1.5%	2.0%	2.5%	3.0%	3.5%	4.0%	4.5%	5.0%	5.5%	6.0%	7.0%	8.0%	9.0%	10.0%	11.0%	12.0%	20.0%
1	0.99010	0.98522	0.98039	0.97561	0.97087	0.96618	0.96154	0.95694	0.95238	0.94787	0.94340	0.93458	0.92593	0.91743	0.90909	0.90090	0.89286	0.83333
2	0.98030	0.97066	0.96117	0.95181	0.94260	0.93351	0.92456	0.91573	0.90703	0.89845	0.89000	0.87344	0.85734	0.84168	0.82645	0.81162	0.79719	0.69444
3	0.97059	0.95632	0.94232	0.92860	0.91514	0.90194	0.88900	0.87630	0.86384	0.85161	0.83962	0.81630	0.79383	0.77218	0.75131	0.73119	0.71178	0.57870
4	0.96098	0.94218	0.92385	0.90595	0.88849	0.87144	0.85480	0.83856	0.82270	0.80722	0.79209	0.76290	0.73503	0.70843	0.68301	0.65873	0.63552	0.48225
5	0.95147	0.92826	0.90573	0.88385	0.86261	0.84197	0.82193	0.80245	0.78353	0.76513	0.74726	0.71299	0.68058	0.64993	0.62092	0.59345	0.56743	0.40188
6	0.94205	0.91454	0.88797	0.86230	0.83748	0.81350	0.79031	0.76790	0.74622	0.72525	0.70496	0.66634	0.63017	0.59627	0.56447	0.53464	0.50663	0.33490
7	0.93272	0.90103	0.87056	0.84127	0.81309	0.78599	0.75992	0.73483	0.71068	0.68744	0.66506	0.62275	0.58349	0.54703	0.51316	0.48166	0.45235	0.27908
8	0.92348	0.88771	0.85349	0.82075	0.78941	0.75941	0.73069	0.70319	0.67684	0.65160	0.62741	0.58201	0.54027	0.50187	0.46651	0.43393	0.40388	0.23257
9	0.91434	0.87459	0.83676	0.80073	0.76642	0.73373	0.70259	0.67290	0.64461	0.61763	0.59190	0.54393	0.50025	0.46043	0.42410	0.39092	0.36061	0.19381
10	0.90529	0.86167	0.82035	0.78120	0.74409	0.70892	0.67556	0.64393	0.61391	0.58543	0.55839	0.50835	0.46319	0.42241	0.38554	0.35218	0.32197	0.16151
11	0.89632	0.84893	0.80426	0.76214	0.72242	0.68495	0.64958	0.61620	0.58468	0.55491	0.52679	0.47509	0.42888	0.38753	0.35049	0.31728	0.28748	0.13459
12	0.88745	0.83639	0.78849	0.74356	0.70138	0.66178	0.62460	0.58966	0.55684	0.52598	0.49697	0.44401	0.39711	0.35553	0.31863	0.28584	0.25668	0.11216
13	0.87866	0.82403	0.77303	0.72542	0.68095	0.63940	0.60057	0.56427	0.53032	0.49856	0.46884	0.41496	0.36770	0.32618	0.28966	0.25751	0.22917	0.09346
14	0.86996	0.81185	0.75788	0.70773	0.66112	0.61778	0.57748	0.53997	0.50507	0.47257	0.44230	0.38782	0.34046	0.29925	0.26333	0.23199	0.20462	0.07789
15	0.86135	0.79985	0.74301	0.69047	0.64186	0.59689	0.55526	0.51672	0.48102	0.44793	0.41727	0.36245	0.31524	0.27454	0.23939	0.20900	0.18270	0.06491
16	0.85282	0.78803	0.72845	0.67362	0.62317	0.57671	0.53391	0.49447	0.45811	0.42458	0.39365	0.33873	0.29189	0.25187	0.21763	0.18829	0.16312	0.05409
17	0.84438	0.77639	0.71416	0.65720	0.60502	0.55720	0.51337	0.47318	0.43630	0.40245	0.37136	0.31657	0.27027	0.23107	0.19784	0.16963	0.14564	0.04507
18	0.83602	0.76491	0.70016	0.64117	0.58739	0.53836	0.49363	0.45280	0.41552	0.38147	0.35034	0.29586	0.25025	0.21199	0.17986	0.15282	0.13004	0.03756
19	0.82774	0.75361	0.68643	0.62553	0.57029	0.52016	0.47464	0.43330	0.39573	0.36158	0.33051	0.27651	0.23171	0.19449	0.16351	0.13768	0.11611	0.03130
20	0.81954	0.74247	0.67297	0.61027	0.55368	0.50257	0.45639	0.41464	0.37689	0.34273	0.31180	0.25842	0.21455	0.17843	0.14864	0.12403	0.10367	0.02608
21	0.81143	0.73150	0.65978	0.59539	0.53755	0.48557	0.43883	0.39679	0.35894	0.32486	0.29416	0.24151	0.19866	0.16370	0.13513	0.11174	0.09256	0.02174
24	0.76757	0.69954	0.62172	0.55288	0.49193	0.43796	0.39012	0.34770	0.31007	0.27666	0.24698	0.19775	0.15770	0.12440	0.10153	0.08170	0.06588	0.01258
25	0.77977	0.68921	0.60953	0.53939	0.47761	0.42315	0.37512	0.33273	0.29530	0.26223	0.23300	0.18425	0.14602	0.11597	0.09230	0.07361	0.05882	0.01048
28	0.75684	0.65910	0.57437	0.50088	0.43708	0.38165	0.33348	0.29157	0.25509	0.22332	0.19563	0.15040	0.11591	0.08955	0.06934	0.05382	0.04187	0.00607
29	0.74934	0.64936	0.56311	0.48866	0.42435	0.36875	0.32065	0.27902	0.24295	0.21168	0.18456	0.14056	0.10733	0.08215	0.06304	0.04849	0.03738	0.00506
30	0.74192	0.63976	0.55207	0.47674	0.41199	0.35628	0.30832	0.26700	0.23138	0.20064	0.17411	0.13137	0.09938	0.07537	0.05731	0.04368	0.03338	0.00421
31	0.73458	0.63031	0.54125	0.46511	0.39999	0.34423	0.29646	0.25550	0.22036	0.19018	0.16425	0.12277	0.09202	0.06915	0.05210	0.03935	0.02980	0.00351
40	0.67165	0.55126	0.45289	0.37243	0.30656	0.25257	0.20829	0.17193	0.14205	0.11746	0.09722	0.06678	0.04603	0.03184	0.02209	0.01538	0.01075	0.00068

University of Asia Pacific
Department of Civil Engineering
Final Examination Fall 2014
Program: B. Sc. Engineering (Civil)

Course # : CE 203

Course Title: Engineering Geology & Geomorphology

Full Marks: 120 (6 X 20 = 120)

Time: 3 hours

Section A

There are four (4) questions in this section. Answer any three (3):

1. (a) Draw a schematic diagram of the rock cycle and discuss (with at least two examples of each) about igneous, sedimentary and metamorphic rocks according to the cycle. 14
 (b) Describe, in brief, the principal zones of the earth from geologic point of view. 6

2. (a) What is geomorphic process? Distinguish between physical and chemical weathering processes. Mention the names of major chemical weathering processes and discuss any two of them. 7
 (b) For the following basin, x is a constant factor. For what value of x , the flow rate (Q) will be the maximum for the basin? Find the FF and CC of the basin for maximum runoff. 7

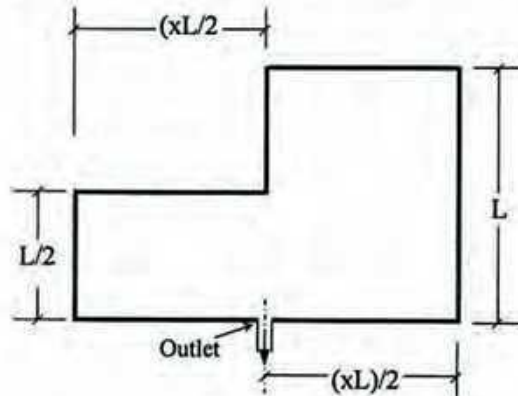

- (c) Classify (mention names only) and draw sketches of different types of faults. 6

3. (a) Discuss with neat sketch of different routes/ways of total runoff (total flow). 7
 (b) Discuss, in brief, the factors affecting runoff. 8
 (c) Calculate Peak runoff for the following facility under the following conditions: 5
 - Rainfall Intensity for the whole area = 2.25 in/hr
 - Co-efficient of runoff for----
 - Concrete paved area = 0.85
 - Asphalt paved area = 0.75
 - Lawn area = 0.25
 - Consider d in yard

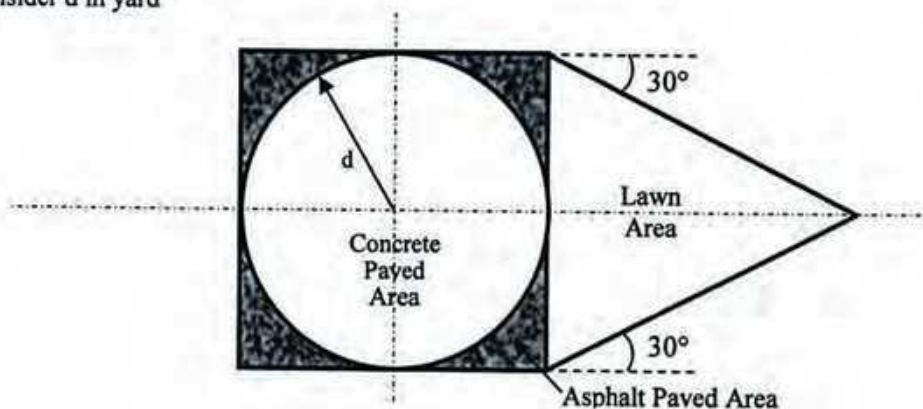

4. Briefly discuss, mention or draw sketches, as asked for, on **any four** of the following topics: 5 X 4 = 20
- (i) Neat sketches of Horst and Graben.
 - (ii) Classification (names only) of folds (based on geometry) and neat sketches of Homocline and Syncline.
 - (iii) Rational method, hydrograph and time of concentration.
 - (iv) Fault classification according to net slip.
 - (v) Surface waves of earthquake (no sketch required)

Section B

There are four (4) questions in this section. Answer any three (3):

5. (a) Prove that $\tau = \gamma_w R_H S$; where symbols carry their usual meanings. 5
 (b) Prove that $H = ae^{-bx}$; where symbols carry their usual meanings. 4
 (c) The longitudinal and cross-sectional profiles of a channel are shown below. Calculate the tractive pressure along the channel. 6

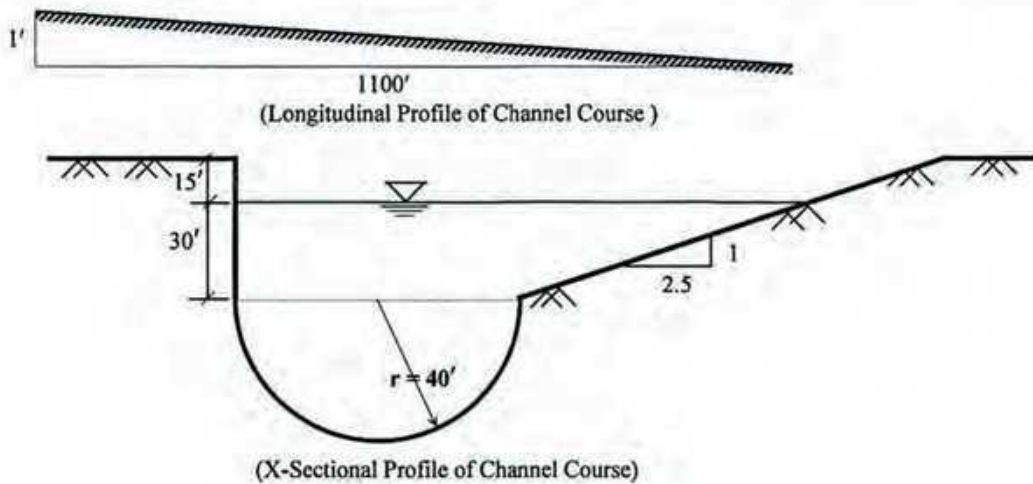

- (d) The cross-sectional profiles at two locations (location-1 and location-2) of a river are shown in the figures below. If all other factors affecting erosion remain constant, which location will exhibit more erosion? Justify your answer. 5

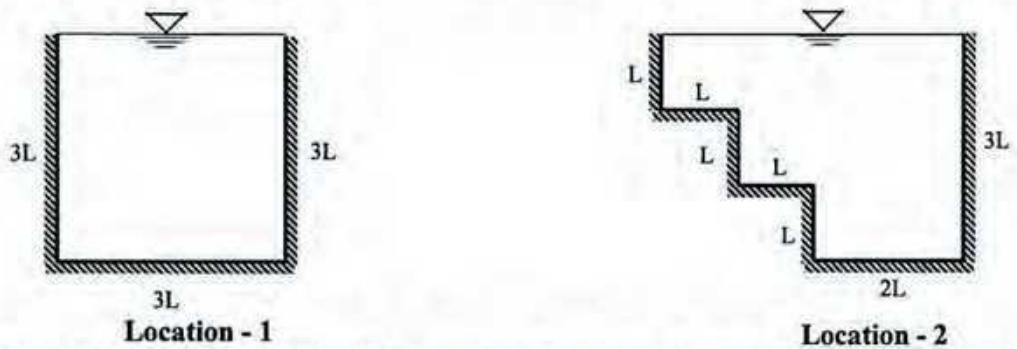

6. (a) What is drainage pattern? Classify drainage pattern (mention names only). Write short notes of dendritic, basin and ring like pattern with neat sketch. 9
 (b) Draw x-section of a typical river valley. Write down the classification of river valley. Also write short notes on the ways valleys are deepened. 7
 (c) For a stream having triangular X-section and $T \lll D$, prove: $\tau \propto T$ 4
 Where symbols carry their usual meanings.

7.

(a) Define river transportation, load, capacity and competence. Write short notes on various types of loads of a river. 6

(b) Using the figure shown below, calculate the horizontal distance between A and C. 4

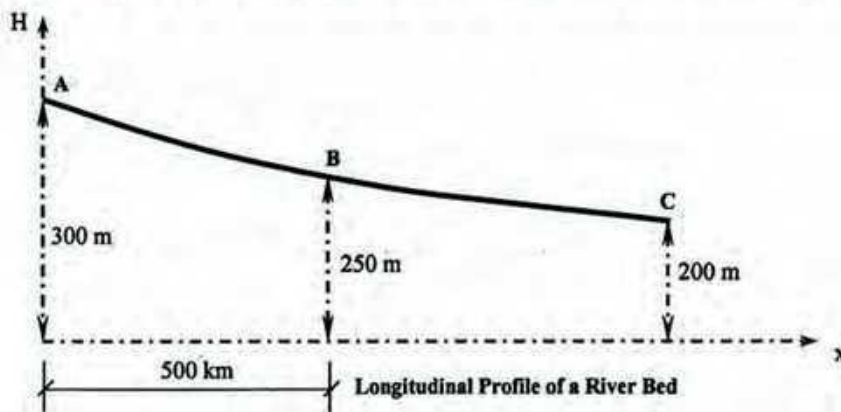

(c) Rank the streams of the following drainage basin having a total catchment area of 8,999 square kilometer. The results of the survey are summarized in the table below. 10

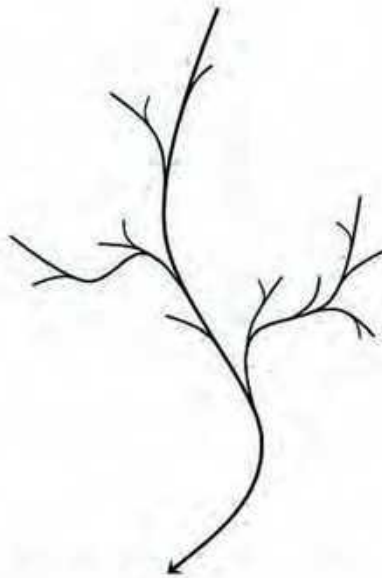

Stream Rank	Average Length (km)
1	7.0
2	18.9
3	44.8
4	99.9

Calculate the following parameters:

(i) Average Bifurcation Ratio (ABR)

(ii) Average Length Ratio (ALR)

(iii) Stream Frequency

8. (a) Define earthquake. Mention the causes of earthquake. Define the major earthquake parameters (geometric) with neat sketches. 8

(b) Discuss liquefaction phenomenon (with basic mechanism) due to earthquake. 7

(c) Tabulate Modified Mercalli intensity scales of earthquake (V to IX). 5

University of Asia Pacific
Department of Civil Engineering
Final Examination Fall 2014
Program: B.Sc Engineering (Civil)

Course Title: Numerical Analysis & Computer Programming
Time: 3 Hours

Course Code: CE 205
Full Marks: 90

Section- A : Answer any 6(Six) out of 8(Eight)

1. Determine the root of the equation $5x^3 - 3x^2 + 2x - 9 = 0$ by Bisection method. Correct upto 4 decimal places. 10

2. Using Euler's modified method, obtain a solution of the equation 10

$$dy/dx = x + |y|$$

with initial condition $y=1$ at $x=0$ for the range $0 \leq x \leq 0.6$ in steps of 0.2

3. Use Cramer's rule to approximate the solution of the following system of linear equations. 10

$$\begin{aligned}x - 3z &= -5 \\2x - y + 2z &= 16 \\7x - 3y - 5z &= 19\end{aligned}$$

4. Fit a second degree parabola to the following data by Least Squares Method. 10

X	1945	1946	1947	1948	1949	1950	1951	1952	1953
Y	382	386	389	390	395	396	396	388	386

5. Using Lagrangian polynomials, find $f(0.25)$ for 10

x	0.1	0.2	0.3	0.4	0.5
f(x)	9.9833	4.9667	3.2836	2.4339	1.9177

6. Use Gauss Jordan method to approximate the solution of the following system of linear equations. 10

$$\begin{aligned}4x - 2y + 3z &= 1 \\x + 3y - 4z &= -7 \\3x + y + 2z &= 5\end{aligned}$$

7. Find $y(1.0)$ using R-K method of order four by solving the equation 10

$$dy/dx = 3x^2 + 2y$$

$y(0) = 1$ with step length 0.5

8. Using Rombergs method, compute 10

$$I = \int_1^3 [1/(1+x+x^2)] dx$$

Take at least up to eight intervals for better accuracy.

Section- B :Answer any 3 (Three) out of 4 (Four)

9. Write a program to find the area (A) and moment of inertia (I) of a circular X-section where diameter is known. $A = \frac{\pi d^2}{4}$, $I = \pi d^4/64$ 10
10. Write a program that calculates the real roots of any quadratic equation $ax^2+bx+c=0$ for given values of a, b and c. 10
11. Write a program to find the summation of $1+3^3+5^3+7^3+\dots+n^3$. 10
12. Write a program that takes two integer variables as input and interchanges them. 10

University of Asia Pacific
Department of Civil Engineering
Final Examination Fall 2014 (Set 2)
Program: B. Sc. Engineering (Civil)

Course Title: Mechanics of Solids II
 Time: 3 hours

Course Code: CE 213
 Full Marks: 100 (= 10 × 10)

[Answer any 10 (ten) of the following 14 questions]

1. Calculate the equivalent polar moments of inertia (J_{eq}) for the three cross-sections shown in Fig. 1 by centerline dimensions [Given: Wall thickness = 0.10" throughout].

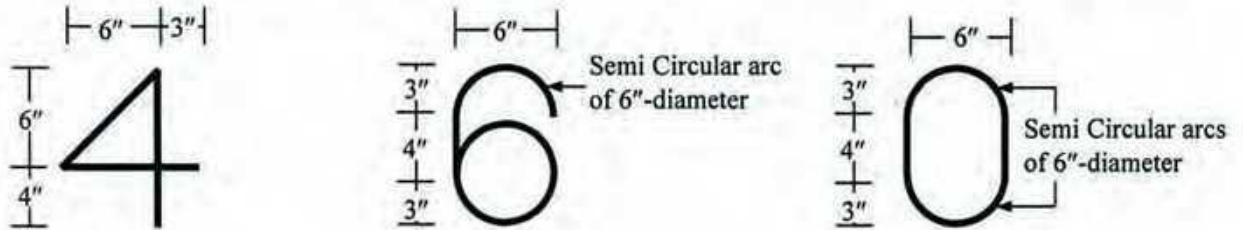

Fig. 1

2. Calculate the torsional rotation at A for the cricket bat $OABC$ subjected to the eccentric force F_z (and resulting torque) as shown in Fig. 2(a), if the point O is
 (i) Free (as shown), (ii) Fixed [Given: Shear Modulus = 2×10^3 MPa].

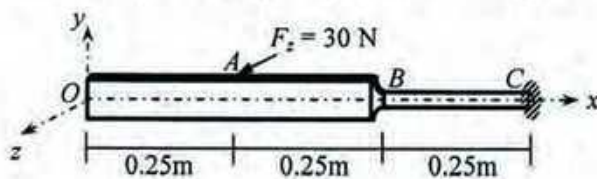

Fig. 2(a)

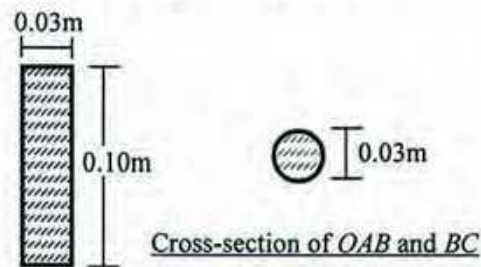

Fig. 2(b)

3. Fig. 3 shows a cricket stump (weighing 1.4 lb) abc inclined 45° with the horizontal. At section b of the stump, calculate the
 (i) Combined normal stress and shear stress
 (ii) Principal stresses and angle of corresponding principal planes.
4. Determine the maximum possible radius of the Mohr's circle of stresses for a cricket ball (with yield strength equal to 100 kPa) if it satisfies the
 (i) Von Mises yield criterion.
 (ii) Tresca yield criterion.

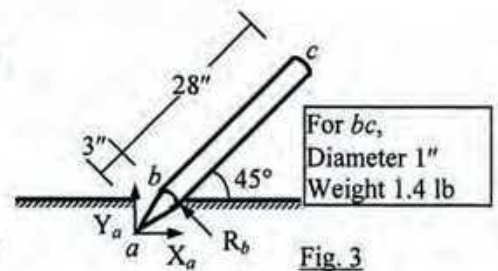

Fig. 3

5. Fig. 4(a) shows a cricketer in his bowling action, supporting the entire body-weight on his right footstep, which is approximated by the section shown in Fig. 4(b).

If his weight ($W = 150$ lb) works through the point G [in Fig. 4(b)], calculate the combined normal stress at point A of his footstep.



Fig. 4(a)

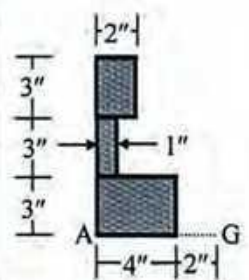

Fig. 4(b)



Fig. 5(a)

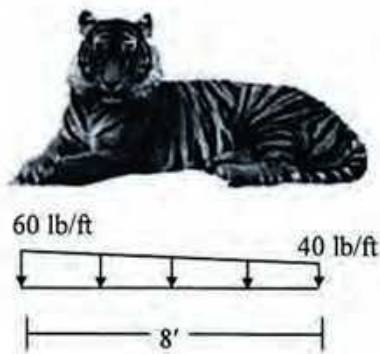

Fig. 5(b)

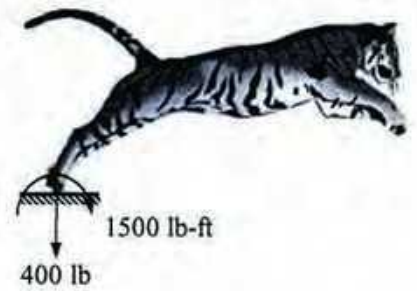

Fig. 5(c)

6. For the beams shown in Fig. 6(a), 6(b) and carrying loads shown in Fig. 5(a), 5(b), 5(c)
- Write down the equations for load $w(x)$ using singularity functions.
 - Write down the boundary conditions.
 - Determine whether the beams are statically determinate or indeterminate.
 - Draw the qualitative deflected shapes of the beams under the given loads.

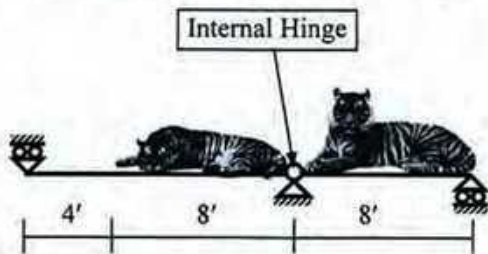

Fig. 6(a)

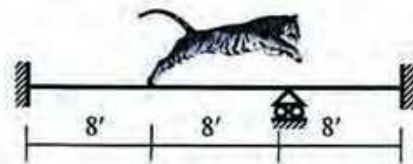

Fig. 6(b)

7. For beam $abcde$ shown in Fig. 7 carrying loads of Fig. 5(a), 5(c), use *Singularity Functions* to calculate
- Vertical deflection at joint b
 - Rotation just left and right of joint c
- [Given: $EI = \text{constant} = 30 \times 10^3 \text{ lb-ft}^2$].

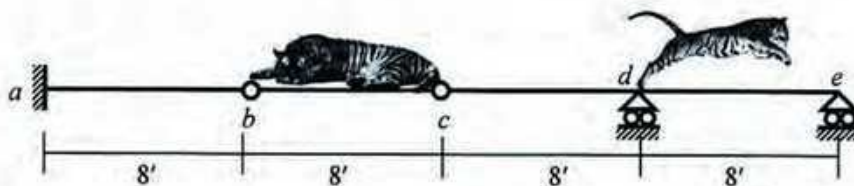

Fig. 7

b and c are
Internal Hinges

- Answer Question 7 using the *Moment-Area Theorems*.
- Answer Question 7 using the *Conjugate Beam Method*.
- Fig. 8 shows statically indeterminate beam abc carrying the load shown in Fig. 5(c). Calculate the vertical deflection at a (support movement) required to make deflection at b equal to zero [Given: $EI_{ab} = 60 \times 10^3 \text{ lb-ft}^2$, $EI_{bc} = 30 \times 10^3 \text{ lb-ft}^2$].

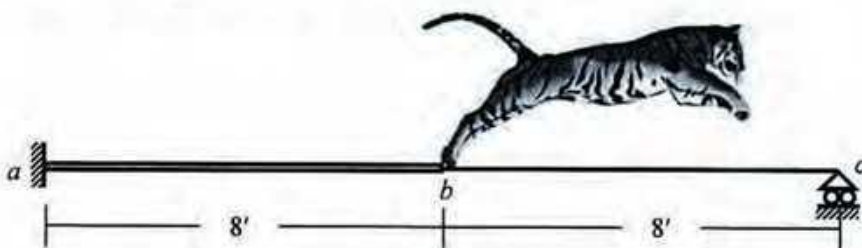

Fig. 8

11. Fig. 9(a) shows an initially imperfect simply supported beam AB [with $v_i(x) = v_{0i} \sin(\pi x/L)$] subjected to concentric compressive force P , and is connected to an initially straight beam BC subjected to the same eccentric compressive force P . Fig. 9(b) shows the cross-section of both beams.

If $v_{0i} = 1''$, $v_{m(a)} = 2''$, $E = 2000$ ksi, determine the eccentricity e required to make $v_{m(b)} = v_{m(a)}$.

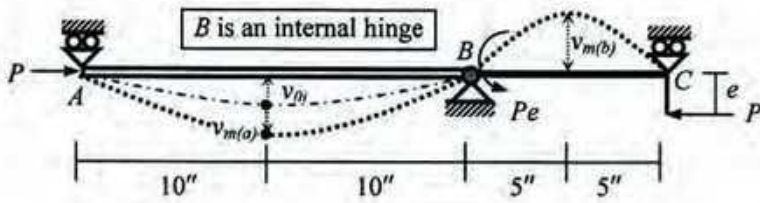
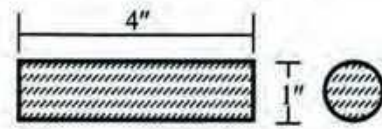

Fig. 9(a)



Cross-section of AB and BC

Fig. 9(b)

12. A 28-in long cricket stump [modeled as cantilever column shown in Fig. 10(a)] has a cross-section shown in Fig. 10(b) and is made of timber whose stress-strain relationship is $\sigma = 12 (\epsilon/\epsilon_u)(e^{-\epsilon/\epsilon_u})$, where σ is the stress (ksi), ϵ is the strain and $\epsilon_u = 0.004$. Calculate the critical load for the column.

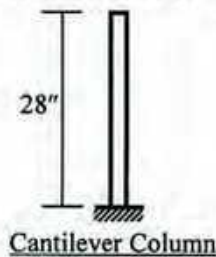

Cantilever Column

Fig. 10(a)

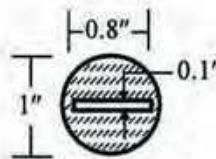

Cross-section

Fig. 10(b)

13. Calculate the Euler buckling force of the columns bc and fg shown in Figs. 11(a), (b), (c) [Given: $E = 2000$ ksi].

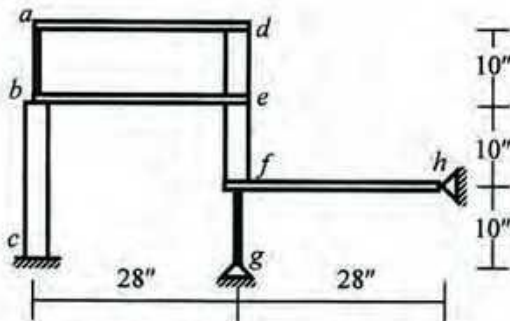
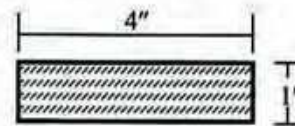

Fig. 11(a)



Cross-section of columns bc, de, ef

Fig. 11(b)



Cross-section of columns ab, fg and all beams

Fig. 11(c)

14. Use the AISC-ASD criteria to calculate the allowable value of F to avoid buckling of any member of the truss shown in Fig. 12 [Given: $E = 200 \times 10^3$ MPa, $f_y = 300$ MPa].

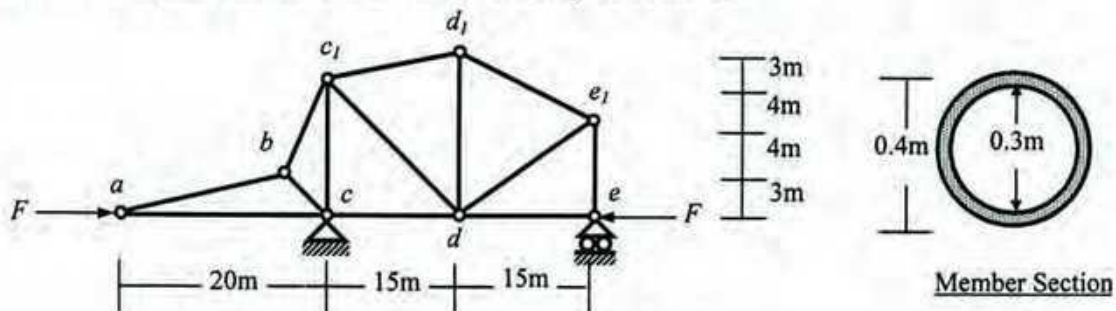

Fig. 12

University of Asia Pacific
Department of Civil Engineering
Final Examination Fall 2014
Program: B.Sc. Engineering (Civil)

Course Title: Fluid Mechanics
Time: 3 hours

Course Code: CE 221
Full Marks: 150

SECTION I

(There are **Four** questions in this section. Answer any **Three** of them.)

1. (a) Prove that "Hydrostatic pressure at a point is same in all directions". (08)
(b) Find the pressure difference between point A and B shown in figure 1(b). (09)
(c) Explain stability of floating/submerged body. (08)
2. (a) What is center of pressure? Derive an expression to determine center of pressure for submerged plane surface. (13)
(b) Draw the hydrostatic pressure variation on the inclined surface AB shown in figure 2(b). Also find the value and location of total hydrostatic force on that inclined surface. All values in the figure 2(b) are in meter. [Unit weight of fluid=12.0 kN/m³, width of AB is 10 m.] (12)
3. (a) Derive Bernoulli's energy equation. Also state its limitation. (13)
(b) A liquid (S=1.50) with a $P_v=40$ kN/m², abs flows through the horizontal pipe as shown in figure 3(b). $P_{atm}=70$ cm of Hg. Find the maximum theoretical flow rate without cavitation to occur. Neglect head loss. (12)
4. (a) Classify different types of energy associated with fluid flow. (05)
(b) A fluid (S=1.50) is flowing through a pipe of 1.0 m diameter. The actual velocity is expressed by an equation of $u = 0.25 [1 - 2.25(\frac{r}{0.75})^2]$ where u =velocity (m/s) and r = radius (m). Find out mean velocity and energy correction factor. (10)
(c) A fluid (S=2.8) is flowing through a pipe of 4 inch radius under an absolute pressure of 150 kN/m² and with a discharge of 3.5 m³/s. Neglecting friction, determine the total head if the pipe is 1 ft below the datum line. (10)

SECTION II

(There are **Four** questions in this section. Answer any **Three** of them.)

5. (a) What is cavitation? What are the effects and remedies of cavitation? (09)
(b) Draw actual and ideal velocity distribution for a pipe flow. (04)
(c) A fluid (S=1.75) is flowing as shown in figure 5(c). Section 1-1 has an absolute pressure of 175 kN/m² and elevation of +15 m. Section 2-2 has an elevation of

+5m and absolute pressure of 125kN/m^2 . Section 1-1 and 2-2 has diameter of 250 cm and 150 cm respectively. Find out velocities at section 1-1 and section 2-2. Neglect head loss.

6. (a) What is Reynolds Number? How can you classify fluid flow on the basis of Reynolds Number? (05)
 (b) What is momentum correction factor? Why is it needed? Derive an equation for momentum correction factor. (15)
 (c) What is equivalent roughness? List different losses in pipe flow. (05)
7. (a) Determine the magnitude of the resultant force exerted on the double nozzle shown in figure 7(a). Both nozzle jets have a velocity of 10 m/s. The axis of the pipe and both nozzles lie in a horizontal plane. Neglect friction. [$S=1.35$]. (10)
 (b) State impulse momentum equation. (05)
 (c) An oil ($S=1.5$) having a kinematic viscosity of 60 stokes is flowing through a pipe of 400 cm radius. Find the theoretical maximum discharge under laminar flow condition. (10)
8. (a) A fluid is flowing in a series of pipes which is shown in figure 8(a). Determine total head loss for flowing liquid from A to B. Consider both major and minor loss. Use moody diagram for friction factor. Given that velocity in pipe 1 is 1.50 m/s and $k_c=0.04$. Use table 8(1) for k_c . Pipe properties are given as below: (20)

Pipe No	Diameter (mm)	Length (km)	Equivalent Roughness(e), mm
1	500	0.50	0.25
2	300	0.85	0.30
3	400	0.65	0.275

- (b) Define Cross sectional mean velocity and discharge. (05)

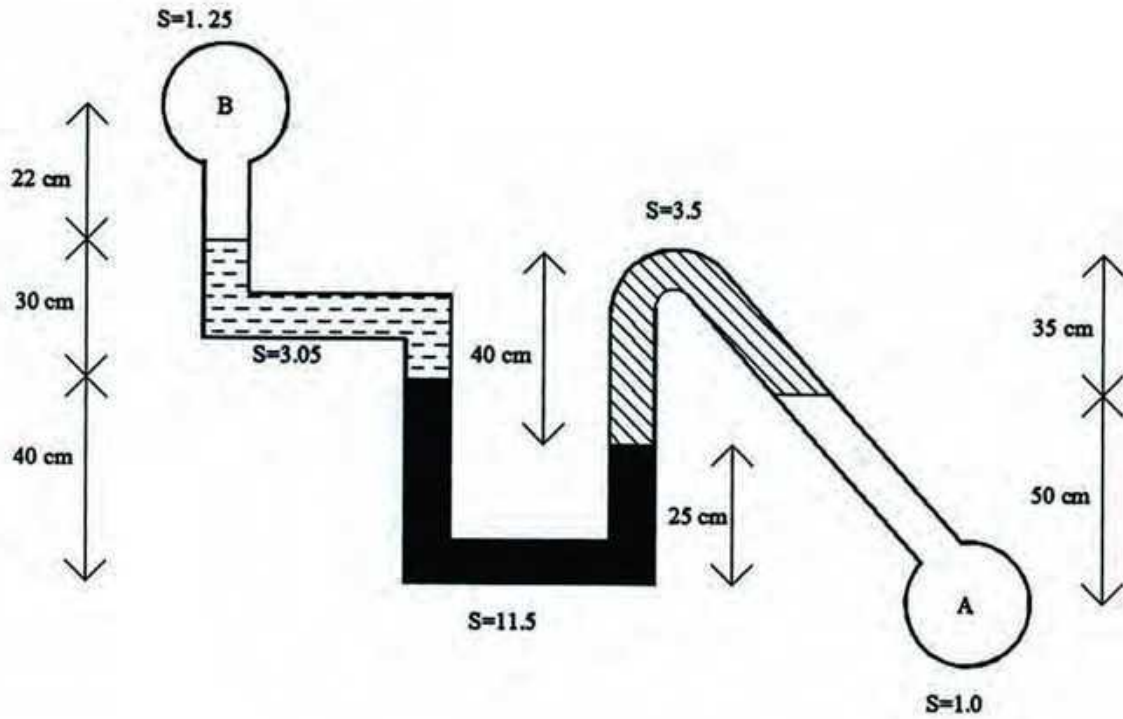

Figure 1(b)

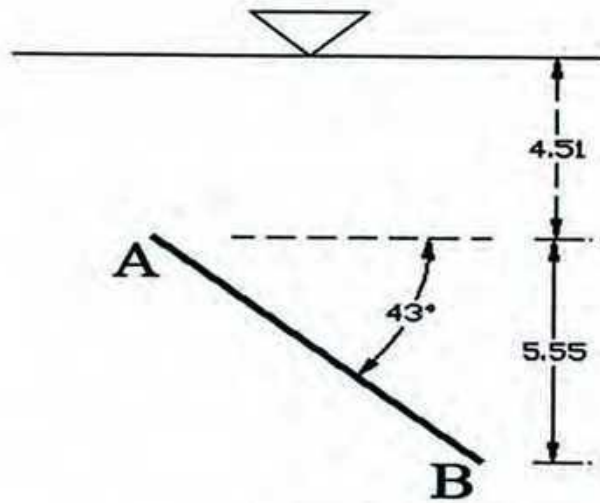

Figure 2(b)

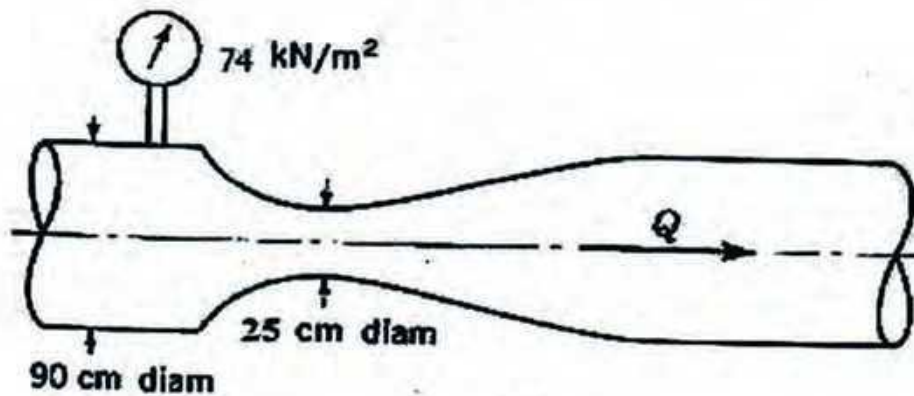

Figure 3(b)

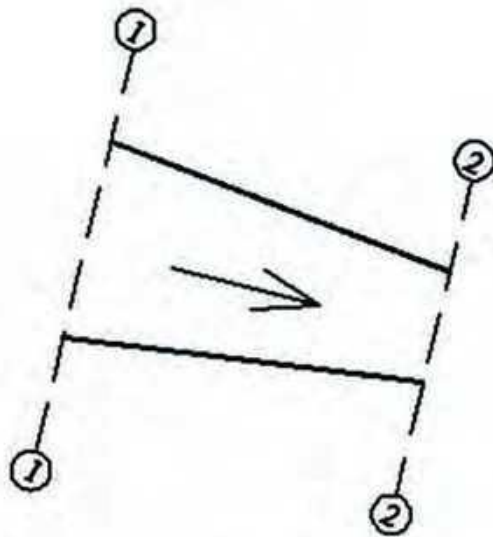

Figure 5(c)

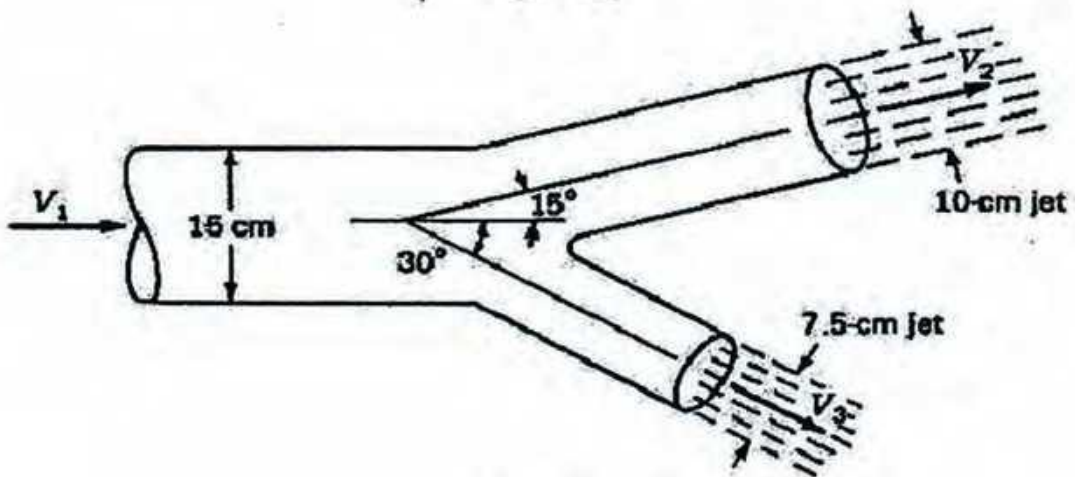

Figure 7(a).

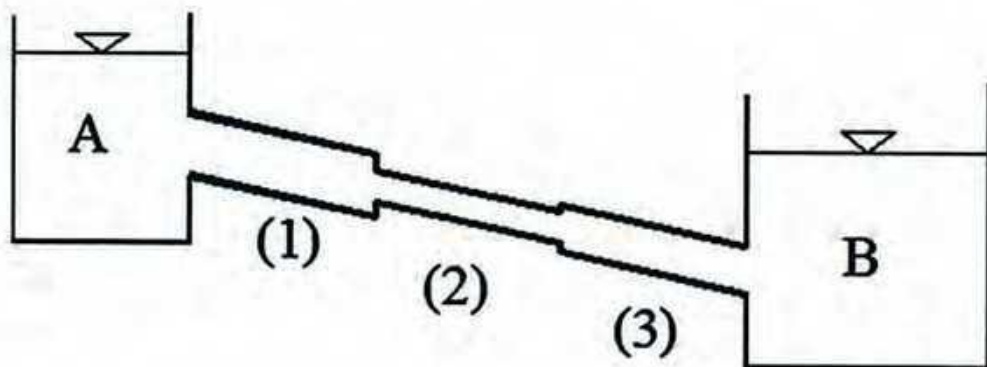

Figure 8(a).

Table 8.1

D_2/D_1	0.0	0.2	0.4	0.6	0.8
k_c	0.5	0.42	0.36	0.28	0.15

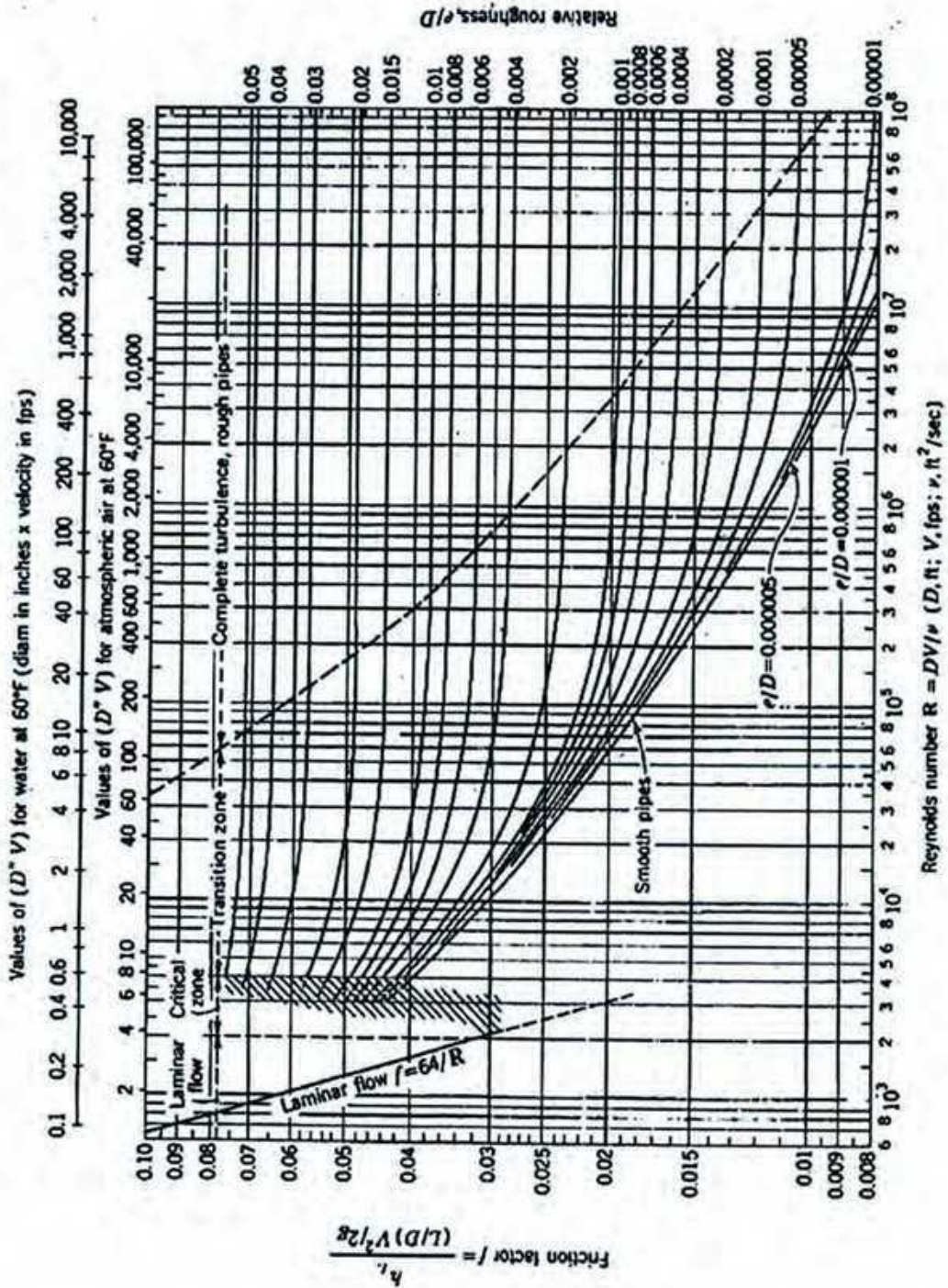

Figure Moody Diagram

University of Asia Pacific
Department of Civil Science and Engineering
Semester Final Examination, Fall-2014
Program: B.SC Engineering (2nd Year/2nd Semester)

Course Title: Principle of Economics

Course Code: ECN 201

Credit: 2.00

Time: 2 Hours

Full Marks: 50

Answer any **five** from the following questions:

1. (a) What are the features of monopoly ? Explain deadweight loss with a diagram. (6)
- (b) In case of a monopolist: $P = 200 - 4Q$, $TC = 5Q + 4$ (4)
- Find out the profit maximizing price and quantity. (4)
2. (a) Calculate Nominal GDP, Real GDP, GDP Deflator : Here, Base Year = 2010 (6)

Year	Price of X	Quantity of X	Price of Y	Quantity of Y
2010	240	25	210	30
2013	265	30	300	36

- i. Estimate the Nominal GDP for 2010 and 2013. ii. What is the Real GDP in 2013?
- iii. Find the GDP deflator for 2013
- (b) What are the differences between GDP Deflator and CPI? Define: GDP Deflator. (4)
3. How can economy revive itself after recession? What kind of policies should be taken to tackle the problem of recession? Explain (10)
4. What is inflation? Explain the reasons behind inflation (10)
5. (a) Suppose price of a consumer basket of goods in year 2000=160 and in 2010=235. Find the CPI in 2010. What is the inflation rate for 2010? [Base Year= 2000] (5)
- (b) What are the consequences of inflation? Explain. (5)
6. Explain different types of unemployment. (10)

University of Asia Pacific
Department of Basic Sciences & Humanities
Semester Final Examination, Fall-2014
Program: B. Sc. Engineering (Civil)
2nd year/ 2nd semester

Course Title: Mathematics IV
 Time: 3(Three) hour

Course Code: MTH 203

Credit: 3.00
 Full Marks: 150

N.B: There are two sections in the question paper namely "**SECTION A**" and "**SECTION B**". You have to answer from both sections according to the instruction mentioned in each section.

SECTION A

There are **FOUR** questions in this section. Answer any **THREE**.

1. Solve the differential equation $y'' - 2y' - y = 2e^x - 10 \sin x$. [25]
2. Solve the differential equation $y'' - 4y' + 3y = 9x^2 + 4$, $y(0) = 6$, $y'(0) = 8$. [25]
3. Find the orthogonal trajectories of the family of curves $x^2 + y^2 = c^2$. [25]
4. Find a family of oblique trajectories that intersect the family of straight lines $y = cx$ at angle 45° . [25]

SECTION B

There are **FOUR** questions in this section. Answer any **THREE**.

5. Find the Fourier series for the function $f(x) = x^2$, $-\pi < x < \pi$. [25]
 Hence show that $\frac{\pi^2}{12} = 1 - \frac{1}{2^2} + \frac{1}{3^2} - \frac{1}{4^2} + \dots$
6. (a) Define Laplace Transform and Inverse Laplace Transform. Show that $\int_0^{\infty} \frac{\sin at}{t} dt = \frac{\pi}{2}$ [15]
 (b) Evaluate $L^{-1} \left\{ \frac{4s+2}{s^2+8s+16} \right\}$ [10]
7. Solve the IVP by Laplace Transform: $Y'' - 3Y' + 2Y = 4e^{2t}$, $Y(0) = -3$, $Y'(0) = 5$ [25]
8. Solve the partial differential equation by Laplace Transform: $\frac{\partial u}{\partial t} + \frac{\partial u}{\partial x} = x$, $x > 0$, $t > 0$ [25]
 with the boundary and initial condition: $u(0, t) = 0$, $t > 0$ & $u(x, 0) = 0$, $x > 0$

Best of Luck

University of Asia Pacific
Department of Civil Engineering
Final Examination Fall 2014
Program: B.Sc. Engineering (Civil)

Course Title: Structural Engineering I
Time: 3.00 Hours

Course Code: CE 311 (A)
Full Marks: 100 (10×10)

There are Fourteen (14) questions. Answer any Ten (10).

1. Classify each of the structures shown below as statically determinate or statically indeterminate, stable or unstable. If statically indeterminate, report the number of degrees of indeterminacy.

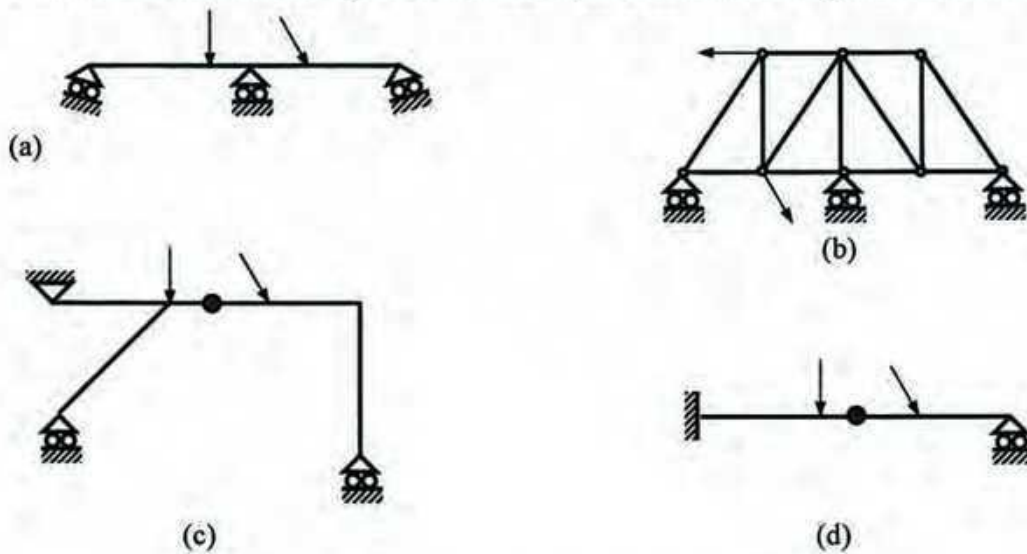

2. Draw the shear force and bending moment diagram for the entire structure in the following figure.

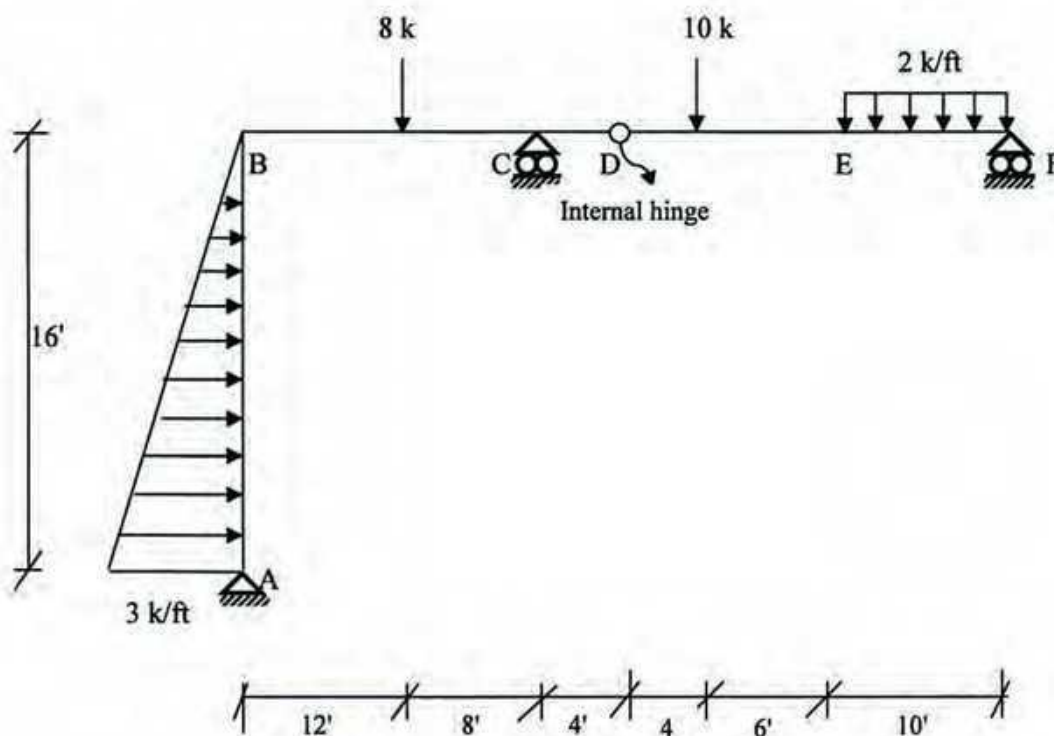

3. For the beam shown below, draw Influence lines for (i) Reaction at B, (ii) Shear at C, (iii) Shear just left of support D and (iv) Moment at C.

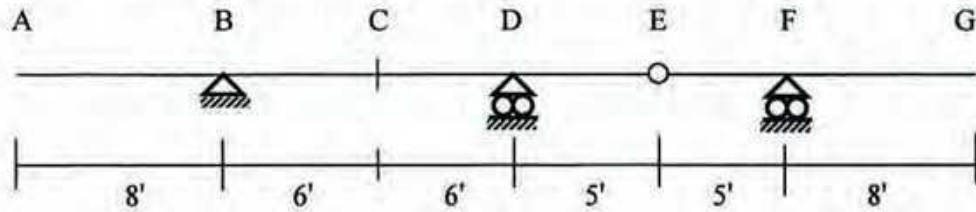

4. Calculate the maximum bending moment at the midpoint of a simply supported beam of span 80 ft due to the wheel loads shown in the figure below.

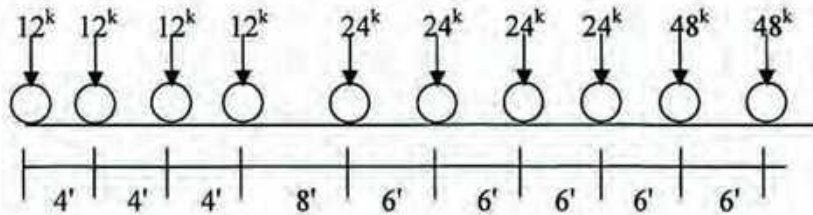

5. Calculate the maximum shear at 20' right of support A for a simply supported beam of span 80 ft due to the wheel loads shown in Question 4.
6. Calculate the maximum reaction at left support A of a simply supported beam of span 60 ft due to the axle loads of a heavy freight locomotive shown below.

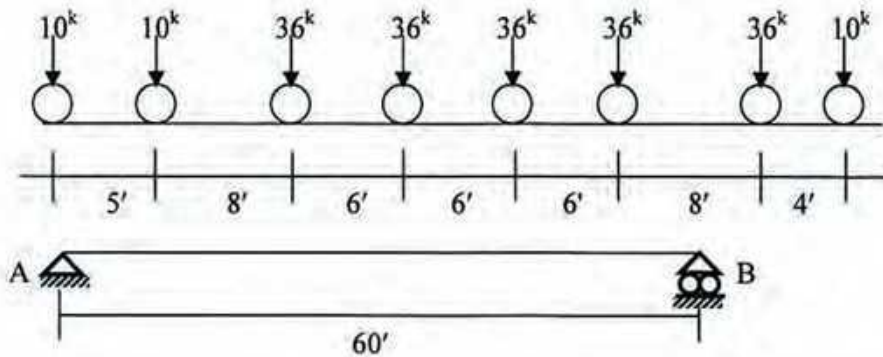

7. Calculate the maximum bar force U_3L_3 of the truss for the moving wheel loads shown in following figure.

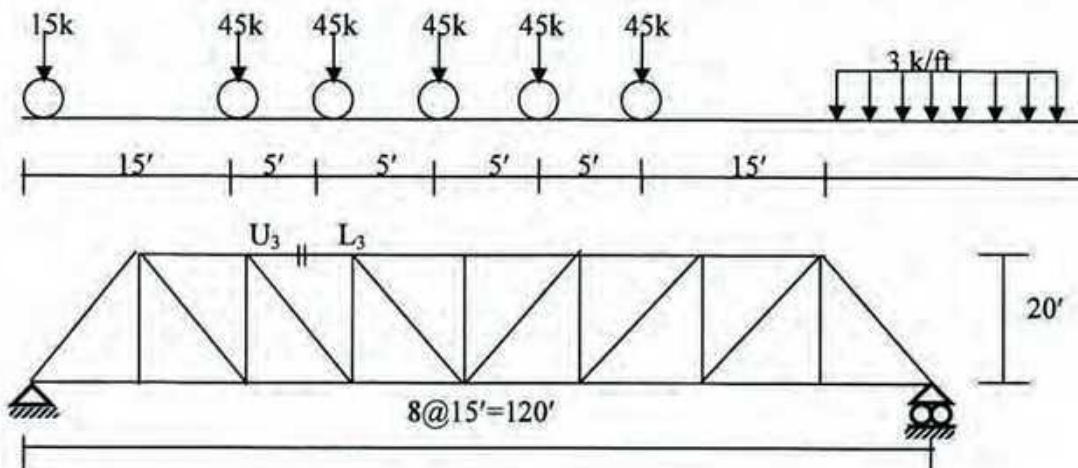

8. Draw influence line diagrams for bar forces of BC, CI and IJ for the truss shown in the figure below. Unit load moves from A to G.

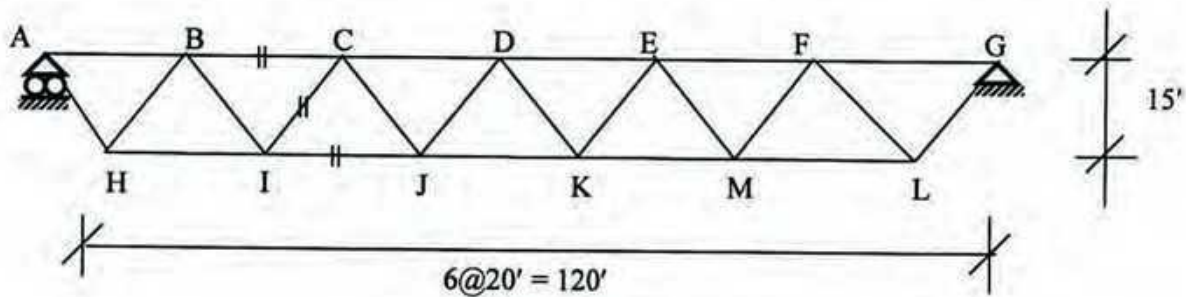

9. Calculate the absolute maximum bending moment of a simply supported beam of span 30 ft due to the wheel loads shown below.

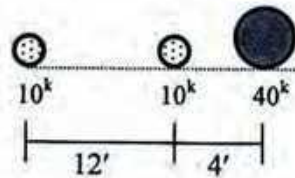

10. Girder AB supports a floor system shown in the figure below. Draw the influence line for
 i) Floor beam reaction at panel point 3.
 ii) Support reaction at A
 iii) Shear in panel 2-3
 iv) Bending moment for girder at panel point 2.

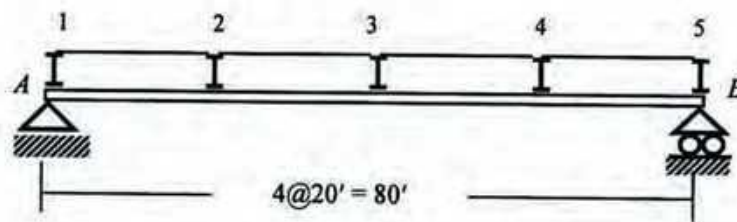

11. Using influence lines, calculate the maximum shear force and maximum bending moment at D due to a dead load of 4 kips per ft. and moving uniform load of 3 kips per ft.

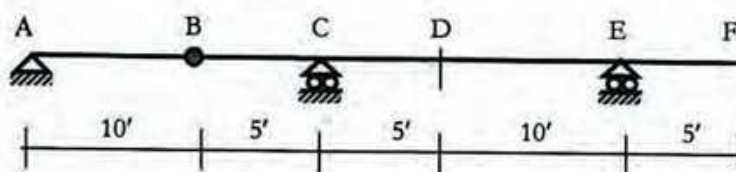

12. a) Derive the "General Cable Theorem".
 b) The cable shown below has supports A and E that lie at same elevation. Point C is on the cable 7 m below the line AE. Using general cable theorem determine the sags at B and D.

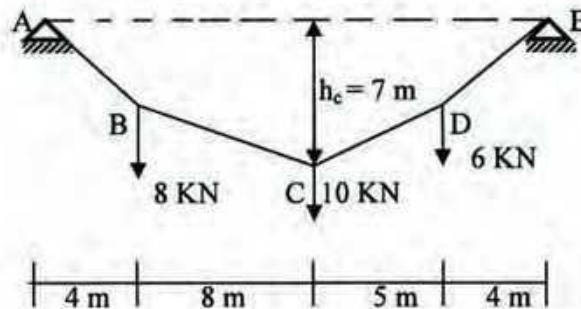

13. Calculate the (i) sustained wind pressure, (ii) sustained wind force at each story of the three-storied residential building (shown below) subjected to a basic wind speed of 210 km/hr with Exposure B.

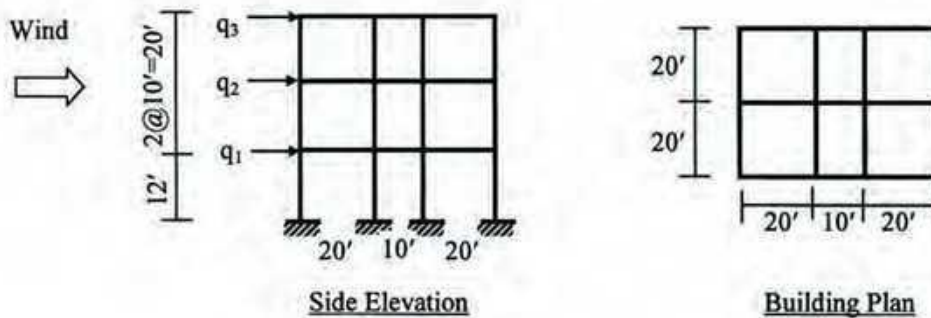

14. Calculate the (i) seismic base shear force, (ii) seismic force at each story of the three-storied hospital building (RCC) shown below located in Dhaka (Zone 2). Assume the structure to be a special moment resisting frame built on soil condition S_2 , carrying a dead load of 200 lb/ft² (including partition load) and live load of 75 lb/ft².

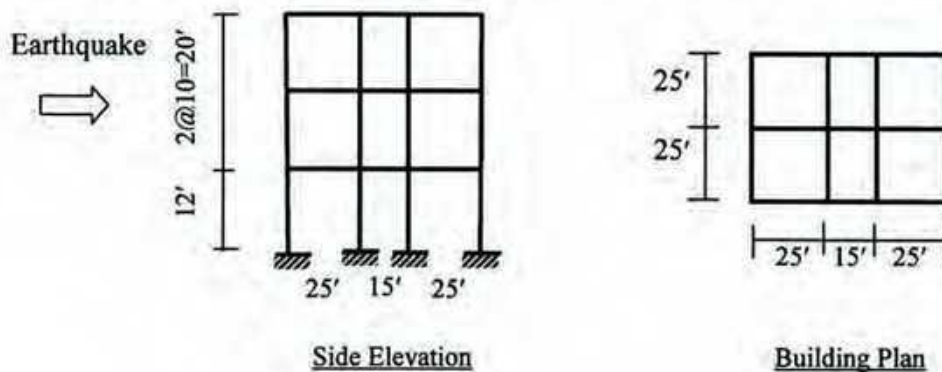

Wind Load Calculation

Table 6.2.9
Structure Importance Coefficients, C_I for Wind Loads

Structure Importance Category (see Table 6.1.1 for Occupancy)	Structure Importance Coefficient, C_I
I Essential facilities	1.25
II Hazardous facilities	1.25
III Special occupancy structures	1.00
IV Standard occupancy structures	1.00
V Low-risk structures	0.80

Table 6.2.10
Combined Height and Exposure Coefficient, C_z

Height above ground level, z (metres)	Coefficient, C_z ⁽¹⁾		
	Exposure A	Exposure B	Exposure C
0-4.5	0.368	0.801	1.196
6.0	0.415	0.866	1.263
9.0	0.497	0.972	1.370
12.0	0.565	1.055	1.451
15.0	0.624	1.125	1.517
18.0	0.677	1.185	1.573
21.0	0.725	1.238	1.623
24.0	0.769	1.286	1.667

Note : (1) Linear interpolation is acceptable for intermediate values of z .

Table 6.2.11
Gust Response Factors, G_h and G_z ⁽¹⁾

Height above ground level (metres)	G_h ⁽²⁾ and G_z		
	Exposure A	Exposure B	Exposure C
0-4.5	1.654	1.321	1.154
6.0	1.592	1.294	1.140
9.0	1.511	1.258	1.121
12.0	1.457	1.233	1.107
15.0	1.418	1.215	1.097
18.0	1.388	1.201	1.089
21.0	1.363	1.189	1.082
24.0	1.342	1.178	1.077

Note : (1) For main wind-force resisting systems, use building or structure height h for z .
(2) Linear interpolation is acceptable for intermediate values of z .

Table 6.2.15 (1)
Overall Pressure Coefficients, \bar{C}_p (2) for Rectangular Buildings with Flat Roofs

h/B	L/B					
	0.1	0.5	0.65	1.0	2.0	≥ 3.0
≤ 0.5	1.40	1.45	1.55	1.40	1.15	1.10
10.0	1.55	1.85	2.00	1.70	1.30	1.15
20.0	1.80	2.25	2.55	2.00	1.40	1.20
≥ 40.0	1.95	2.50	2.80	2.20	1.60	1.25

Note:(1) These coefficients are to be used with Method-2 given in Sec 2.4.6.6a(ii). Use $\bar{C}_p = \pm 0.7$ for roof in all cases.
(2) Linear interpolation may be made for intermediate values of h/B and L/B .

Earthquake Load Calculation

Table 6.2.23
Structure Importance Coefficients I, I'

Structure Importance Category (see Table 6.1.1 for occupancy)	Structure Importance Coefficient	
	I	I'
I Essential facilities	1.25	1.50
II Hazardous facilities	1.25	1.50
III Special occupancy structures	1.00	1.00
IV Standard occupancy structures	1.00	1.00
V Low-risk Structures	1.00	1.00

Table 6.2.24
Response Modification Coefficient for Structural Systems, R

Basic Structural System ⁽¹⁾	Description of Lateral Force Resisting System	R (2)
c. Moment Resisting Frame System	1. Special moment resisting frames (SMRF)	
	i) Steel	12
	ii) Concrete	12
	2. Intermediate moment resisting frames (IMRF), concrete ⁽⁴⁾	8
	3. Ordinary moment resisting frames (OMRF)	
i) Steel	6	
ii) Concrete ⁽⁵⁾	5	

Table 6.2.25
Site Coefficient, S for Seismic Lateral Forces ⁽¹⁾

Site Soil Characteristics		Coefficient, S
Type	Description	
S ₁	A soil profile with either : a) A rock-like material characterized by a shear-wave velocity greater than 762 m/s or by other suitable means of classification, or b) Stiff or dense soil condition where the soil depth is less than 61 metres	1.0
S ₂	A soil profile with dense or stiff soil conditions, where the soil depth exceeds 61 metres	1.2
S ₃	A soil profile 21 metres or more in depth and containing more than 6 metres of soft to medium stiff clay but not more than 12 metres of soft clay	1.5
S ₄	A soil profile containing more than 12 metres of soft clay characterized by a shear wave velocity less than 152 m/s	2.0
<p>Note : (1) The site coefficient shall be established from properly substantiated geotechnical data. In locations where the soil properties are not known in sufficient detail to determine the soil profile type, soil profile S₃ shall be used. Soil profile S₄ need not be assumed unless the building official determines that soil profile S₄ may be present at the site, or in the event that soil profile S₄ is established by geotechnical data.</p>		

University of Asia Pacific
Department of Civil Engineering
Final Examination Fall 2014
Program: B. Sc. Engineering (Civil)

Course Title: Structural Analysis & Design I
 Time: 3.00 Hours

Course Code: CE 311 (Sec B)
 Full Marks: 100 (=10×10)

*There are fourteen (14) questions in this paper. Answer any ten (10).
 Assume any missing data reasonably. Symbols have their usual meaning.*

1. Calculate the force on each hanger and also determine the shear force and bending moment at 'P' for the following ABC frame of cable suspension bridge. B is an internal hinge.

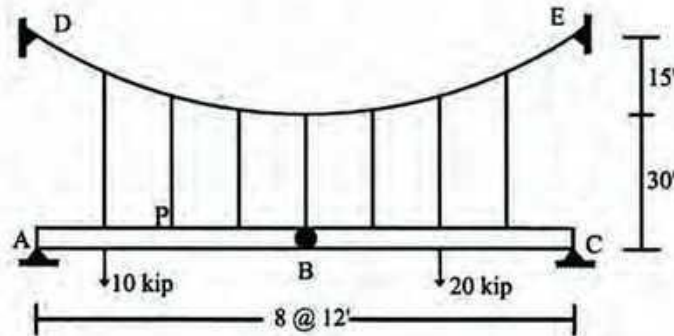

2. Draw shear force and bending moment diagrams of beams and columns of the two-storied frame subjected to lateral load as shown in the figure, assuming (i) Equal share of story shear forces between columns, (ii) Internal hinge at column mid spans.

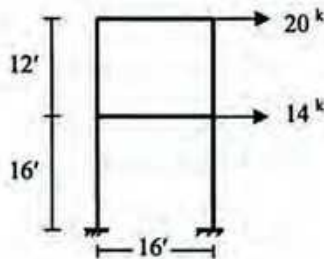

3. For the frame shown below, draw the influence lines for (i) Y_D , Y_E , (ii) V_F , $V_{B(AC)}$, (iii) M_F , $M_{B(AC)}$, if the unit load moves over (a) beam AC, (b) column EC.

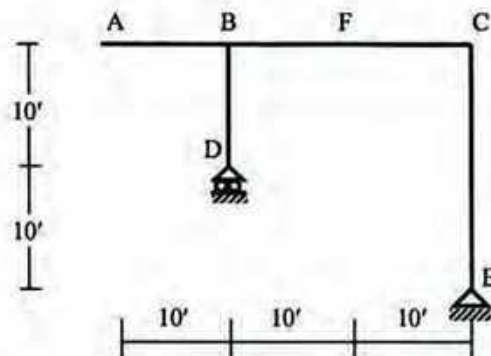

4. For the beam shown below, draw the influence lines for

- (i) R_A, R_C
- (ii) V_B, V_{CR}
- (iii) M_C, M_E

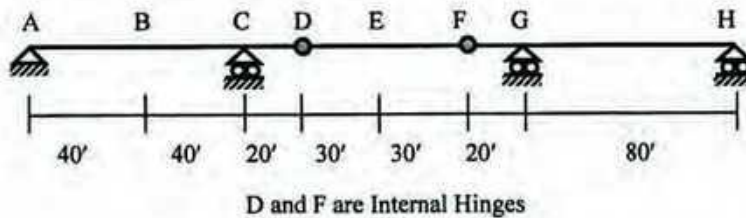

5. For the truss shown below, draw the influence lines for $F_{BC}, F_{BG}, F_{GH},$ and F_{BH} . Note, each bottom cord joint consists of a cross girder and load moves over the floor beam placed over the girders.

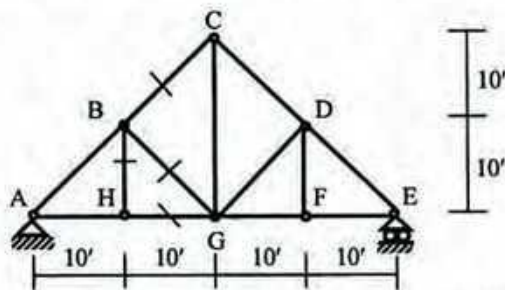

6. Girder AB supports a floor system as shown in the figure below. Draw the Influence line for

- (i) Floor beam reaction at panel point "1" and "2"
- (ii) Support reaction at "A"
- (iii) Shear in panel 1-2 and
- (iv) Bending moment for girder at panel point "2".

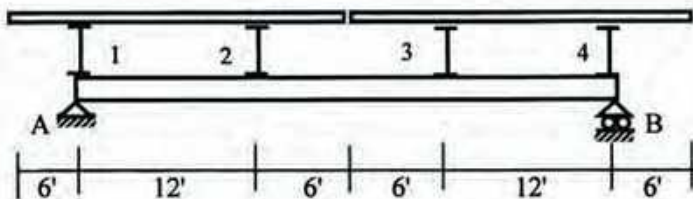

7. Determine - i) Maximum Reaction at support D
ii) Maximum Shear at point D
iii) Maximum Moment at point B

on the beam shown due to

- A single concentrated live load of 10 kips
- A uniform live load of 3 k/ft
- A beam weight of 1k/ft

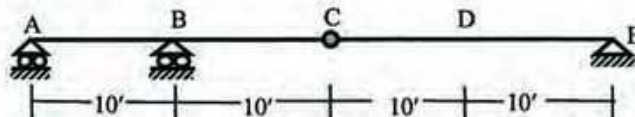

C is an Internal Hinge

Calculate the maximum value of R_A for the wheel load arrangement shown below.

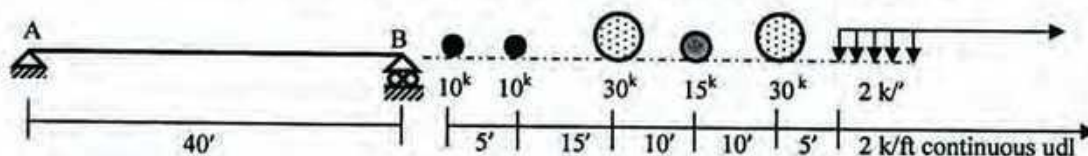

9. Calculate the maximum shear at 15' right of support A for the beam and the moving loads in *Question 8*.
10. Calculate the maximum moment at mid span for the beam and the moving loads in *Question 8*.
11. Calculate the absolute maximum bending moment of a simply supported beam of span 30 ft due to the wheel loads shown in the figure below.

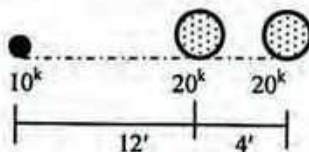

12. (a) State "General cable theorem".
 (b) The cable shown below has supports A and E that lie at the same elevation. Point B on the cable is 2m below the line AE. Use the general cable theorem to calculate the sags at C and D. Also calculate the maximum cable tension.

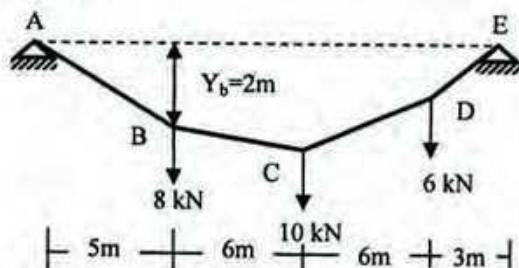

13. Calculate the wind load at each story (i.e. at joints) of a three-storied concrete made school building (shown below) located at a flat terrain in Dhaka (Basic wind speed = 130 mph). Assume the structure to be subjected to Exposure B.

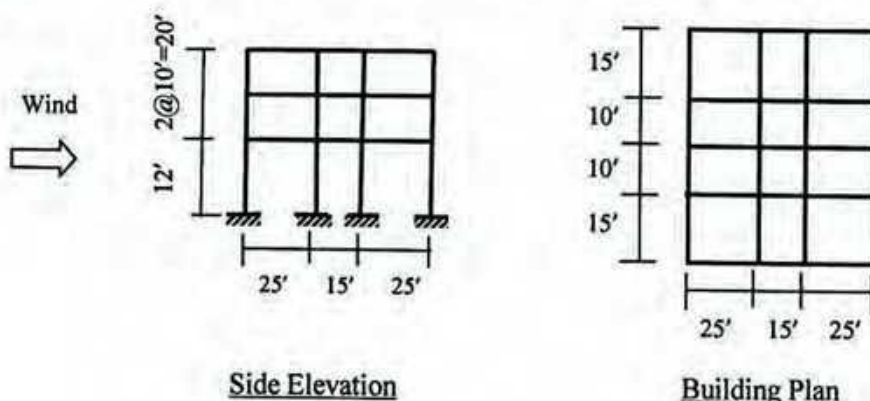

14. Calculate the seismic load at each story (i.e. at joints) of a three-storied concrete made hospital building (shown below) located in Dhaka (Zone 2). Assume the structure to be a Standard Moment Resisting Frame (SMRF) built on soil condition S_3 , carrying a Dead Load of 150 lb/ft^2 and Live load of 40 lb/ft^2 .

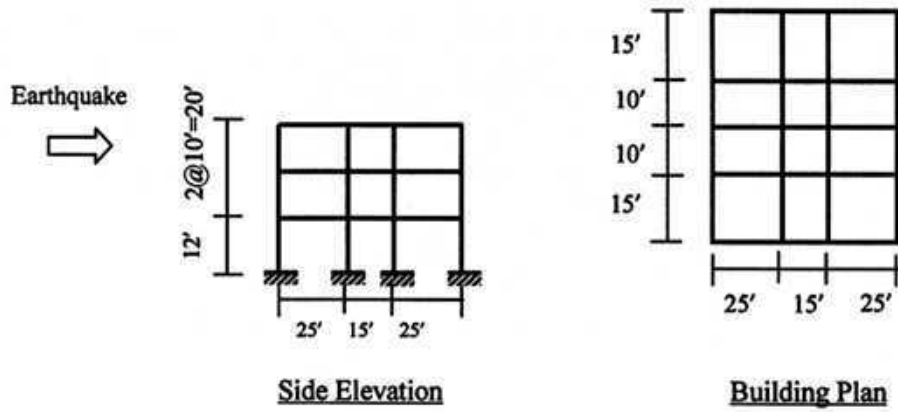

Annexure and Formula
(This Page can be detached)

Wind:

$$q_z = 0.00256 C_1 C_z V_b^2$$

$$p_z = C_G C_t C_p q_z$$

Category	C ₁ or I
Essential facilities	1.25
Hazardous facilities	1.25
Special occupancy	1.00
Standard occupancy	1.00
Low-risk structure	0.80

Height z (ft)	C _z		
	Exp A	Exp B	Exp C
0-15	0.368	0.801	1.196
50	0.624	1.125	1.517
100	0.849	1.371	1.743
150	1.017	1.539	1.890
200	1.155	1.671	2.002
300	1.383	1.876	2.171
400	1.572	2.037	2.299
500	1.736	2.171	2.404
650	1.973	2.357	2.547
1000	2.362	2.595	2.724

Overall Pressure Co-efficient (C_p)
for rectangular buildings with flat roof:

h/B	L/B					
	0.1	0.5	0.65	1.0	2.0	≥ 3.0
≤ 0.5	1.40	1.45	1.55	1.40	1.15	1.10
1.0	1.55	1.85	2.00	1.70	1.30	1.15
2.0	1.80	2.25	2.55	2.00	1.40	1.20
≥ 4.0	1.95	2.50	2.80	2.20	1.60	1.25

Height z (ft)	C _G (for non-slender structures)		
	Exp A	Exp B	Exp C
0-15	1.654	1.321	1.154
50	1.418	1.215	1.097
100	1.309	1.162	1.067
150	1.252	1.133	1.051
200	1.215	1.114	1.039
300	1.166	1.087	1.024
400	1.134	1.070	1.013
500	1.111	1.057	1.005
650	1.082	1.040	1.000
1000	1.045	1.018	1.000

For Flat Terrain, C_t = 1

Earthquake:

$$V = (ZIC/R) W$$

$$C = 1.25 S/T^{2/3}$$

$$T = C_t (h_n)^{3/4}$$

$$F_j = (V-F_1) [w_j h_j / \sum w_i h_i]$$

Soil Type	S
S ₁	1
S ₂	1.2
S ₃	1.5
S ₄	2

Response Modification Factor		R
Moment Resisting Frame System	SMRF (steel)	12
	SMRF (concrete)	12
	IMRF	8
	OMRF (steel)	6
	OMRF (concrete)	5

C_t = 0.083 for steel moment resisting frames
 = 0.073 for RCC moment resisting frames,
 and eccentric braced steel frames
 = 0.049 for all other structural systems

Z = 0.075, 0.15 and 0.25 for Seismic Zones 1, 2 and 3 respectively

Wheel Load:

- $\Delta R = \{(\sum P) d_1 + P'e\}/L - P_1$
- $\Delta V = \{(\sum P) d_1 + P'e + P_0 e_0\}/L - P_1$
- $\Delta M = (P_2 d_1 + P'e) (il/b) - (P_1 d_1 + P_0 e_0) (il/a)$
- $M_{(Max)} = (\sum P/L) (L/2 - a/2)^2 - P b$

University of Asia Pacific
Department of Civil Engineering
Final Examination Fall 2014
Program : B.Sc Engineering (Civil)

Course Title: Design of Concrete Structures I
Time : 3 hr

Course Code: CE 315 (Sec A)
Full Marks : 60

Answer any 3 Questions from each section (Assume any missing data)

Use either USD or WSD method if not specified

The symbols have their usual meaning

Section A

1. a) Calculate the uniformly distributed load (in addition to beam self-weight) which will cause the hollow section (Fig. 1) to begin crack. Given, Simply supported span = 28 ft, $f'_c = 4$ ksi, $f_y = 60$ ksi, $n=9$, concrete unit weight = 150 pcf. (5)

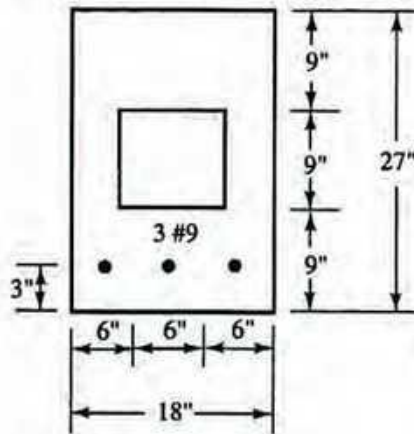

Fig. 1

- b) Use Transformed Area method to determine the allowable resisting moment of the beam (Fig. 1), if the allowable bending stresses of concrete and steel are $f_c = 1.35$ ksi and $f_s = 20$ ksi. (5)
2. a) What is the justification of selecting strength reduction factor (ϕ) based on net tensile strain (ϵ_t)? Discuss the variation of ϕ with ϵ_t as given in ACI code addressing the tension controlled and compression controlled design. (3)
- b) A rectangular concrete beam of width $b = 14$ " is limited by architectural considerations to a maximum total depth $h = 32$ ". The beam must carry a service (i.e. unfactored) DL moment of 200 k-ft and service LL moment of 450 k-ft. Design the flexural reinforcement for the beam using compression steel if necessary. Assume double layer tension reinforcement. Use, $d=28$ ", $d' = 3$ ", $f'_c = 4$ ksi, $f_y = 60$ ksi, $n = 9$. (7)

3. Design a T beam for the floor system shown in Fig 2. Given, $M_D = 200$ k-ft, $M_L = 400$ k-ft, $f'_c = 4000$ psi, $f_y = 60000$ psi, $f_s = 24$ ksi, $n=9$ and simple span= 24 ft. (10)

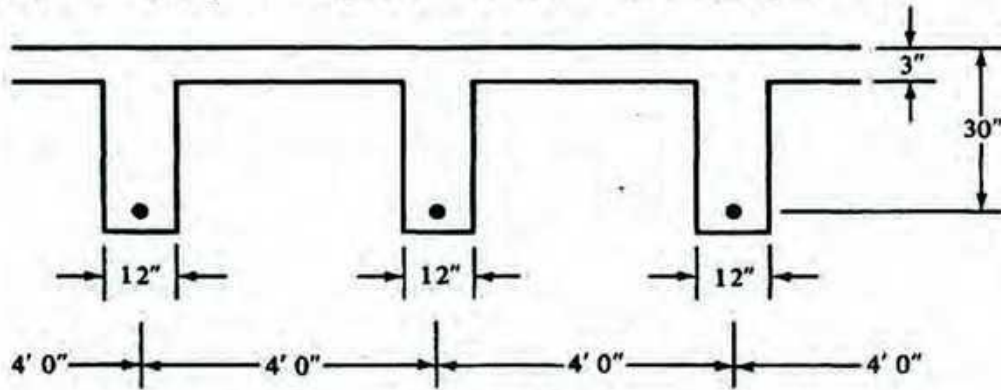

Fig. 2

4. Design the beam (Fig. 3) for shear with a 1.5 k/ft service DL over entire span and a 30 kip concentrated service LL at midspan. Also show the stirrup spacing over the half span. Use #3 U stirrups. Given, $f'_c = 4000$ psi, $f_y = 60000$ psi, $f_s = 24$ ksi. Loads are unfactored. (10)

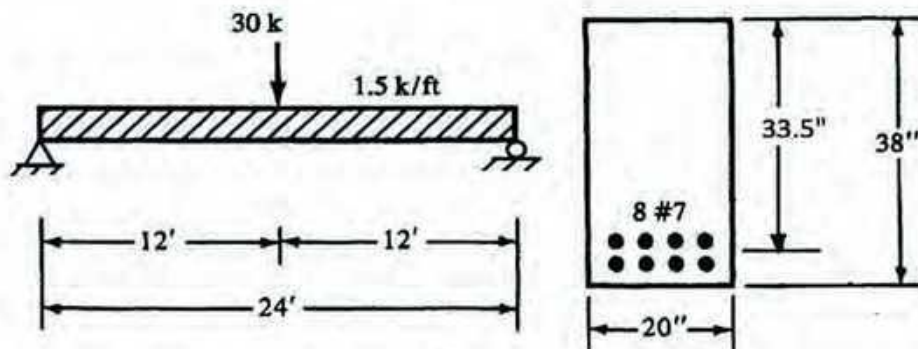

Fig. 3

Section B

5. a) Differentiate between USD and WSD. Which method of design provides maximum factor of safety? Justify your answer. (2)
- b) A rectangular beam has a width of 12" and an effective depth to the centroid of the tension reinforcement of 17". The tension reinforcement consists of three no. 9 bars in a row. Calculate the design moment capacity of the beam using both USD and WSD. Given, $f'_c = 5$ ksi, $f_y = 60$ ksi, $f_s = 24$ ksi, $E_s = 29000$ ksi, $E_c = 3222.22$ ksi. (8)

6. a) Write down the ACI specifications for determining the effective width of T-beams and L-beams. (2)
- b) Define development length. Explain the relationship of (i) Location of reinforcement (2) and (ii) Coating of bars, with development length by means of the factors Ψ_t and Ψ_e . (2)
- c) Calculate the nominal and design moment capacity of the beam shown in Fig. 4. (6)
- Given, $f'_c = 5$ ksi, $f_y = 60$ ksi, $f_s = 24$ ksi, $E_s = 29000$ ksi, $E_c = 3222.22$ ksi.

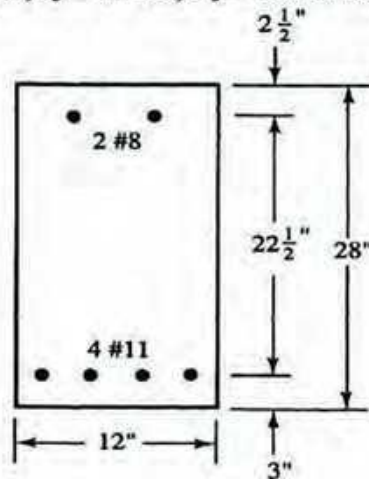

Fig. 4

7. a) The beam of Fig. 5 is subjected to a service DL of 1 k/ft and service LL of 2 k/ft. After designing the beam for maximum flexure, 3-#10 uncoated bar has been selected. Given, normal weight concrete $f'_c = 5$ ksi, $f_y = 60$ ksi, $f_s = 24$ ksi, $E_s = 29000$ ksi, $E_c = 3222.22$ ksi.
- (i) Calculate the theoretical cut-off point of the centre rebar. (3)
- (ii) Also, calculate the actual cut-off point of the centre rebar considering the fact that, adequate development length is to be provided. Consider simplified equation for development length calculation. (5)

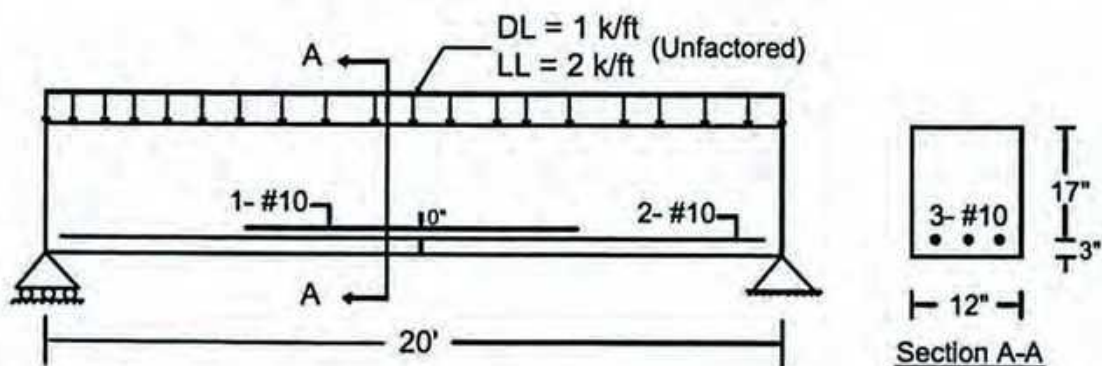

Fig. 5

b) Although the reaction from the support surface introduces vertical compression at the end of the beam, the maximum shear to be considered for design will be computed at a distance 'd' from the interior face of support, explain why? (2)

8. a) A reinforced concrete one way slab is built integrally with its supports and consists of two equal spans. The slab panels are continuous in one direction and each panel has a clear span of 16 ft (Fig. 6). The service live load is 100 psf and 4000 psi concrete is specified for use with steel with a yield stress equal to 60000 psi. Design the slab and show the reinforcement detailing. Note, this slab is okay for serviceability. Use ACI moment co-efficients (indicated on the top of the longitudinal slab section shown in Fig. 6). (8)

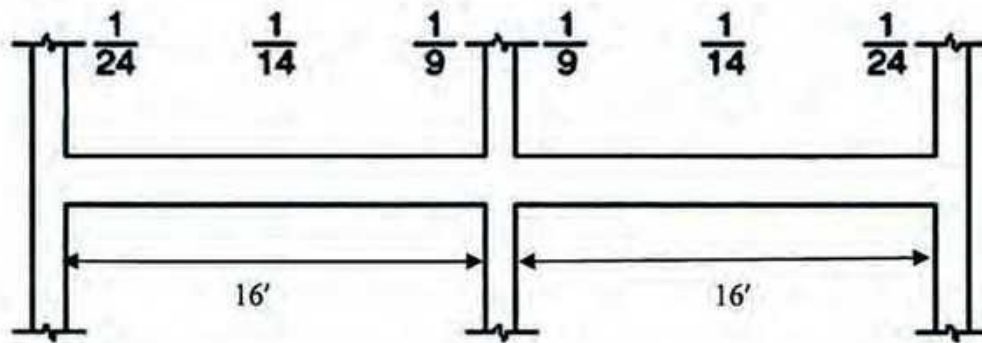

Fig. 6

b) How can you differentiate one-way slab from two-way slab system? (2)

This page can be detached

Formulae:

$$\phi M_n = M_u = \phi A_s f_y d \left(1 - \frac{1}{1.7} \frac{\rho f_y}{f'_c} \right)$$

$$\rho = \frac{0.85 f'_c}{f_y} \left(1 - \sqrt{1 - \frac{2R_n}{0.85 f'_c}} \right)$$

$$\phi = 0.65 + (\epsilon_t - 0.002) \left(\frac{250}{3} \right)$$

$$\frac{M_u}{\phi b d^2} = \rho f_y \left(1 - \frac{1}{1.7} \frac{\rho f_y}{f'_c} \right)$$

$$A_{s \min} = \frac{3 \sqrt{f'_c}}{f_y} b_w d$$

$$\text{nor less than } \frac{200 b_w d}{f_y}$$

$$A_s f_y = 0.85 f'_c \beta_1 c b + A'_s \left(\frac{c - d'}{c} \right) (0.003) (29,000)$$

$$M_n = A_{s1} f_y \left(d - \frac{a}{2} \right) + A_{s2} f_y (d - d')$$

$$\beta_1 = 0.85 - \left(\frac{f'_c - 4000}{1000} \right) (0.05) \geq 0.65$$

$$a = \frac{A_s f_y}{0.85 f'_c b} = \beta_1 c$$

$$\phi M_n = \phi A_s f_y \left(d - \frac{a}{2} \right)$$

$$k = \sqrt{2 \rho n} + (\rho n)^2 - \rho n$$

$$j = 1 - \frac{k}{3}$$

$$f_c = \frac{2M}{b d^2 k j}$$

$$f_s = \frac{M}{A_s j d}$$

$$f_c = 0.45 f_c$$

$$V_s = \frac{V_u - \phi V_c}{\phi}$$

$$s = \frac{A_v f_y d}{V_s}$$

$$s = \frac{A_v f_y}{0.75 \sqrt{f'_c} b_w}$$

$$\leq s = \frac{A_v f_y}{50 b_w}$$

Compute maximum spacing: $d/2 \leq 24$ in., if $V_s \leq 4 \sqrt{f'_c} b_w d$.

Compute maximum spacing: $\frac{d}{4} \leq 12$ in., if $V_s > 4 \sqrt{f'_c} b_w d$.

$$\frac{\ell_d}{d_b} = \frac{f_y \psi_t \psi_e \lambda}{20 \sqrt{f'_c}}$$

University of Asia Pacific
Department of Civil Engineering
Final Examination Fall 2014
Program: B.Sc. Engineering (Civil)

Course Title: Design of Concrete Structures I
 Time: 3.0 hr

Course Code: CE 315
 Full Marks: 100

Part A

[Answer any three (03) out of the following four (04) questions]

Full Marks: 30 [=3*(5+5)]

1. (i) Explain the difference between analysis and design of an RC section.
 (ii) What is a doubly reinforced RC section? Explain how it differs from a singly reinforced section.
2. (i) What is the balanced steel ratio (ρ_b)? Why does ACI recommend maximum steel ratio $< \rho_b$?
 (ii) What are the load and resistance factors? Explain why they are used in USD.
3. (i) What is one-way slab? Give some common examples of one-way slabs in engineering structures.
 (ii) Narrate the ACI code provisions for choosing the minimum thickness of one-way slabs.
4. (i) What is development length? Mention the factors influencing development length of deformed bars
 (ii) Explain why the development length of compression bars is smaller than that of tension bars.

Part B

[Answer any seven (07) out of the following ten (10) questions]

Full Marks: 70 [=7*10]

[Given: $f_c' = 3$ ksi, $f_y = 60$ ksi, $f_{call} = 1.35$ ksi, $f_{sall} = 30$, ksi for all questions]

[Assume reasonable values for any missing data]

5. (a). Calculate the nominal compression and tensile force capacity of the RC section.
 (b). Calculate the stresses in concrete and steel when the section is subjected to one-fifth of its ultimate load capacity.

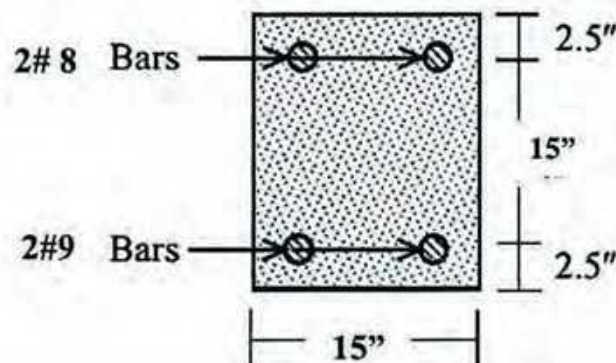

6. (a). Calculate the 'Cracking' positive moment capacity (M_{cr}) of the RC section shown below when allowable tensile stress in concrete, $f_t = 0.351$ ksi
 (b) Calculate the allowable positive moment (M_{call} and M_{sall}) in the same RC section when it is cracked.

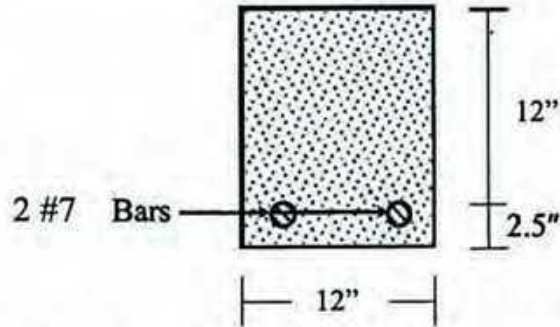

7. Use WSD Method to design the simply supported RC beam as shown, consider self-weight of the beam section.

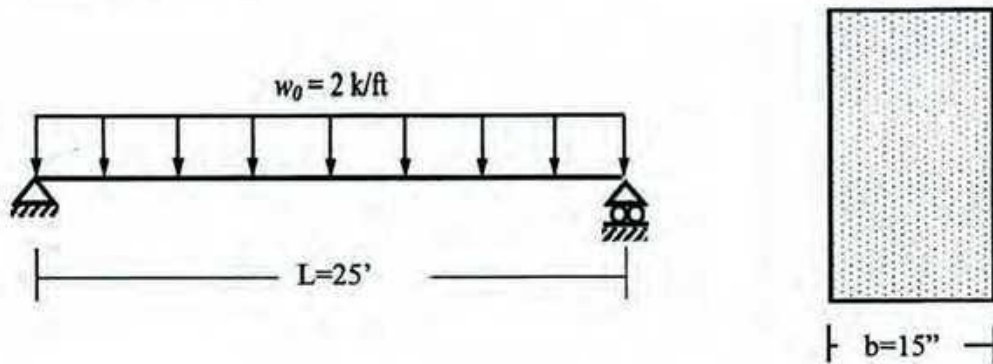

8. Calculate the nominal moment capacity of the singly reinforced beam sections using Whitney's rectangular stress block.

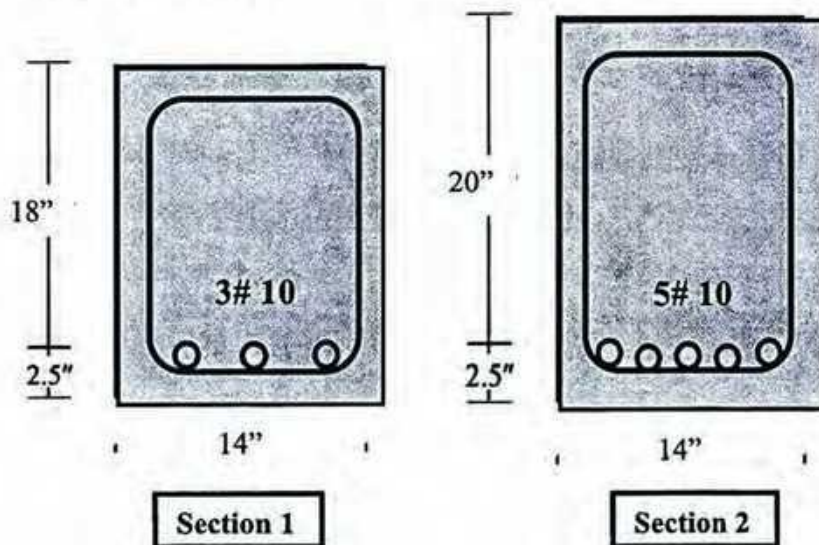

9. A beam section ($b = 15''$, $h = 25''$, $d = 22''$, clear cover = $1.5''$), made of normal-density concrete with $f'_c = 3$ ksi, is reinforced with epoxy coated 2#10 bars ($d_b = 1.25''$, $A_s = 3.5$ in², with $f_y = 60$ ksi), whereas the reinforcement required from structural analysis is 3.10 in², in addition to #3 stirrups @6" c/c, Calculate the development length l_d of the bars, using given table in formula sheet.

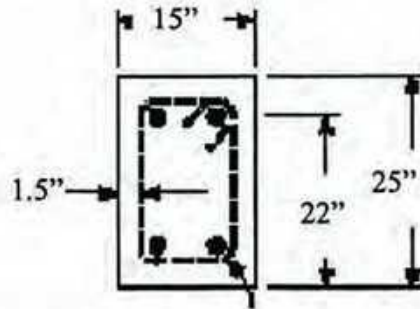

10. Design the RC slab shown below (carrying FF = 45 psf, RW = 55 psf, LL = 60 psf, in addition to self weight) by WSD method.

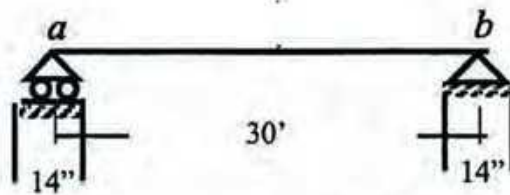

11. Use the ACI provisions to calculate the concrete shear strength for a beam section with $A_s = 5.5$ in², $b = 12''$, $h = 30''$, $d = 26''$, when (i) shear force $V_u = 50$ kip, $M_u = 100$ k-ft (ii) compressive force $N_u = 100$ kip, (iii) tensile force $N_u = 100$ kip.
12. Use the USD Method to design the vertical stirrups for the simply supported RC beam loaded as shown, in addition to self-weight (assume column dimension = $14'' \times 14''$).

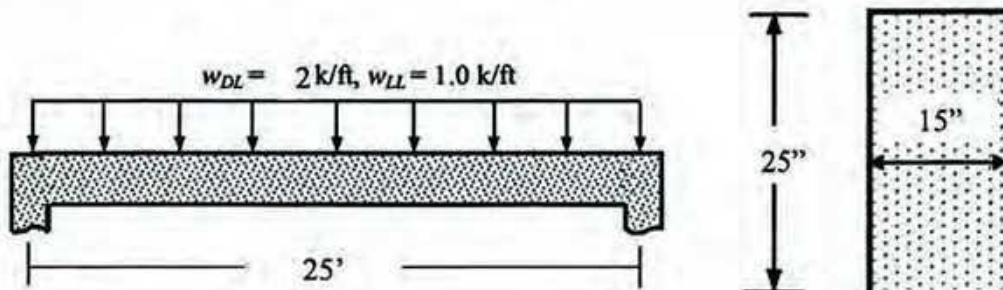

13. Using USD method, determine, total load, b_{eff} for the T-beam loaded as shown below, in addition to its self-weight if it is part of a beam system carrying a 4" thick slab (with $FF = 60$ psf, $RW = 80$ psf and $LL = 150$ psf, $\phi = 0.9$) a transverse distance of 12' c/c apart. Check whether this beam acts like T beam (Note: you do not need to calculate reinforcements).

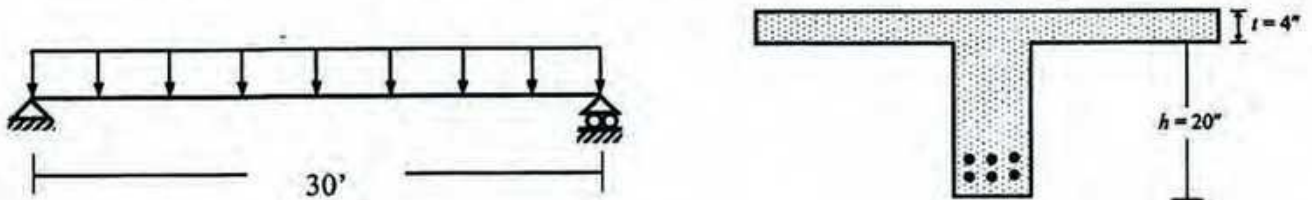

14. Use the WSD Method to design the doubly reinforced simply supported RC beam loaded as shown below, in addition to its self-weight.

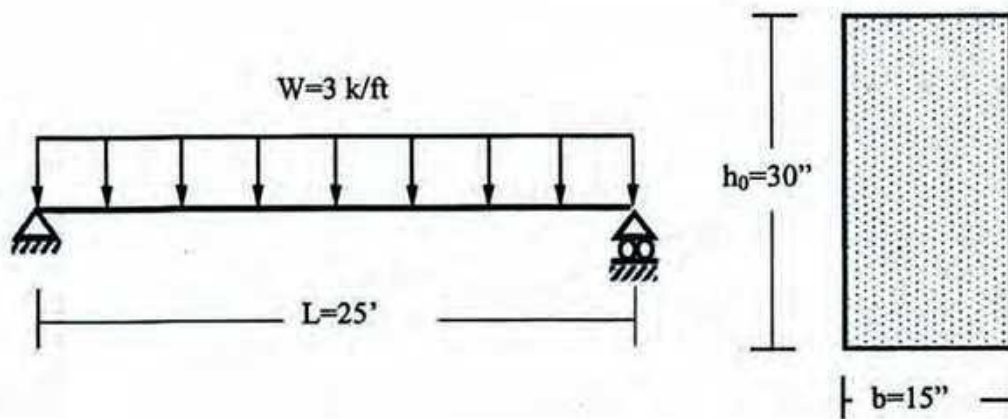

development length of deformed bars in tension $l_d/d_b = (3/40) (f_y/\sqrt{f'_c}) (\alpha\beta\gamma\lambda) / \{(c + K_{tr})/d_b\}$

Table 10.1: Parameters of Development Length of Tension Bars

Symbol	Parameter	Variable	Value
α	Reinforcement Location Factor	* Horizontal Reinforcement over $\geq 12"$ concrete	1.3
		* Other Reinforcement	1.0
β	Coating Factor	* Epoxy-coated bars with cover $< 3d_b$ or clear spacing $< 6d_b$	1.5
		* All other epoxy-coated bars or wires	1.2
		* Uncoated bars	1.0
		* Maximum value of $\alpha\beta$	1.7
γ	Reinforcement Size Factor	* $\geq \#7$ bars	1.0
		* $\leq \#6$ bars and deformed wires	0.8 (?)
λ	Lightweight Aggregate Concrete Factor	* When lightweight aggregate concrete is used	1.3
		* When normal-weight concrete is used	1.0
c	Spacing or Cover Dimension (in)	* Bar center to nearest concrete cover * One-half the c/c spacing of bars	Smaller than both
K_{tr}	Transverse Reinforcement Index	S = Maximum spacing of transverse reinforcement A_{tr} = Area of all transverse reinforcement within S f_y = Yield strength of transverse reinforcement, ksi n = No. of bars being developed along the plane of splitting	$A_{tr}f_y/(1.5Sn)$

Shear Design

* $S = A_v f_y d / (V_{ext} - V_{ci}) = A_v f_y / \{(v_{ext} - v_c) b\}$ for vertical stirrups, and

Summary of ACI Shear Design Provisions (Vertical Stirrups)

	WSD	USD	Additional Provisions
Design Shear Force	V_w	$V_n = V_u/\phi$ [$\phi = 0.75$]	Calculated at d from Support face
Min ^m Section Depth	$V_w/5\sqrt{f'_c}b_w$	$V_u/8\sqrt{f'_c}b_w$	$f_y \leq 60$ ksi
Concrete Shear Strength v_c	$1.1\sqrt{f'_c}$	$1.9\sqrt{f'_c} + 2500\rho_s(V_u d/M_u)$ OR $2\sqrt{f'_c}$	$\sqrt{f'_c} \leq 100$ psi $V_d/M \leq 1.0$
No Stirrup	$V_w \leq V_u/2$	$V_n \leq V_u/2$	
Max ^m Spacing	$d/2, 24" S = A_v f_y / 50b_w$	$d/2, 24" S = A_v f_y / 50b_w$	To be halved if $V_n \geq 4\sqrt{f'_c}b_w d$ OR $V_w \geq 2\sqrt{f'_c}b_w d$ in WSD

Effect of Axial Force on Shear Strength

* Axial Compression

$v_c = 2\sqrt{f'_c} (1 + N_u/2000A_g)$

$v_c = 1.9\sqrt{f'_c} + 2500\rho_s (V_u d/M_u)$

* Axial Tension

$v_c = 2\sqrt{f'_c} (1 + N_u/500A_g)$, but not less than zero (N_u is negative for tension). As an alternative $v_c = 0$

Table 9.1: Minimum Thickness of Non-Prestressed One-way Slabs (for $f_y = 60$ ksi)

Simply Supported	One end continuous	Both ends continuous	Cantilever
$L/20$	$L/24$	$L/28$	$L/10$

Table 9.2: Minimum Ratios of Temperature and Shrinkage Reinforcement in Slabs

Slabs with $f_y = 40$ or 50 ksi	0.0020
Slabs with $f_y \geq 60$ ksi	$0.0018 \times (60/f_y) \geq 0.0014$

University of Asia Pacific
Department of Civil Engineering
Final Examination Fall 2014
Program: B. Sc. Engineering (Civil)

Course Title: Environmental Engineering I
Time: 3 hours

Course Code: CE 331
Full marks: 100

Question No. 1 is compulsory. Answer any FOUR from the rest. (5 X 20 = 100)
(Note: Assume any missing data)

1. A $45 \text{ m}^3/\text{hour}$ drinking water treatment plant is being designed for a small community. The plant needs a settling tank for chemical precipitation followed by disinfection.
- (a) Design (indicate diameter and depth in meters) a **circular** settling basin for the plant using an overflow rate of $0.5 \text{ m}^3/\text{m}^2\text{-hr}$. The detention time is 3 hours. (8)
- (b) What percent of particles with a settling velocity of $0.8 \text{ m}/\text{hour}$ will settle out in this tank? (2)
- (c) The disinfection chlorine demand curve for the river water used in the plant is presented below. Answer questions i) through iv) relevant to this figure

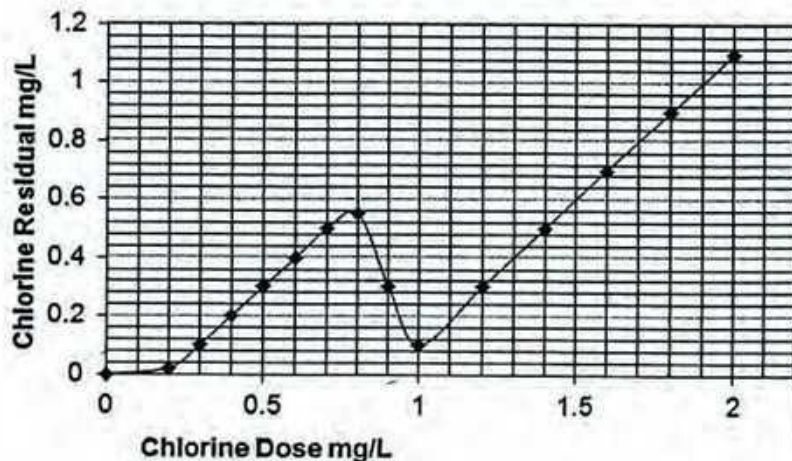

- i) What is the chlorine dose at Break Point in mg/L. (2)
- ii) What is the chlorine dose for maintaining a Free Residual of $0.3 \text{ mg}/\text{L}$? (2)
- iii) What types of residuals are formed during the chlorine doses ranging from 0.2 to $0.8 \text{ mg}/\text{L}$? What compound reacts with chlorine in this region? (3)
- iv) Why does the chlorine residual decrease during the chlorine doses ranging from 0.8 to $1.0 \text{ mg}/\text{L}$? (3)

2. (a) Indicate the chemical or chemicals (write the chemical formula with name) needed for each of the water treatment processes indicated below. Also indicate the name of the precipitate if formed during the treatment process. (11)

Treatment	Chemical Added	Precipitate Formed
Coagulation-Flocculation		
Disinfection		
Softening (hardness removal) If water has only temporary hardness having $\text{Ca}(\text{HCO}_3)_2$, $\text{Mg}(\text{HCO}_3)_2$		
Softening (hardness removal) If water has only MgSO_4		

- (b) A $1,550\text{m}^3/\text{hour}$ drinking water plant needs rapid mix basins for chemical addition. If the detention time is 60 seconds and the volume of the tank cannot exceed 8 m^3 , how many tanks will be needed? What is the power in watts that needs to be supplied to each tank if the velocity gradient G is 80 sec^{-1} ? Assume that the absolute viscosity of the water is 8.91×10^{-4} Pascals.second. (6)
- (c) How can an operator tell when to backwash a rapid sand filter? (3)
3. (a) What are the instances when pumps are required in a water distribution system? When would you use an electric pump and when would you use a centrifugal pump? (6)
- (b) Derive the expression for the pump head for case I and case II as shown below. (5)

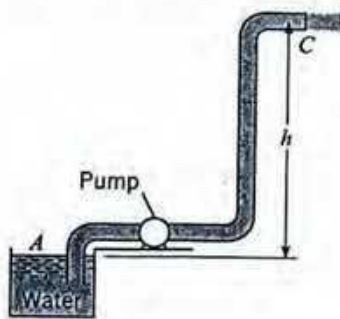

Case I

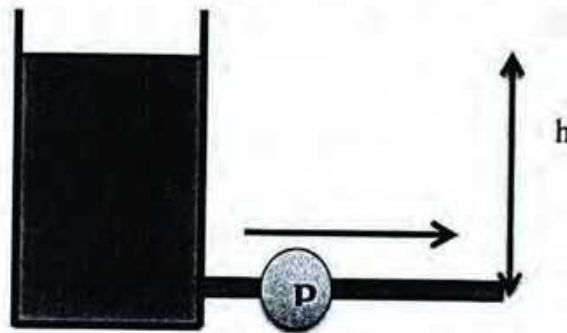

Case II

- (c) Water is supplied at a rate of 35 gallons per capita per day for a city with a population of 50,000. The pump house is located at 135 ft from ground and the treatment plant is located at 220 ft from ground. Total length of the pipe has to be within 2500 ft and the velocity through the pipe has to be maintained at 5 fps. The pump has to work for 10 hours daily at an efficiency of 65%. Design the transmission main (diameter of the pipe) and the pumping

unit (working and break horse power). Assume friction factor, $f = 0.01$. (9)

4. (a) Why is it not feasible to install regular tube wells in coastal areas, although freshwater is available at shallow depths? What kind of adjustment or change is introduced to overcome this difficulty? (4)
- (b) Which alternative water supply options can be adopted if nearby pond water is required to be used for drinking purpose? Explain the technologies in brief. (6)
- (c) Water has to be pumped from an elevation of 25 ft to an elevation of 40 ft. The pump is located at an elevation of 32 ft. The pipe has total length of 1200 ft (supply main, 200 ft and distribution main, 1000 ft), diameter = 10 inches and friction factor = 0.01. Pump characteristics curve has to be plotted using the following data of flow versus head.

Q, gpm	0	1000	2000	3000	4000	5000
H, ft	75	72	70	60	50	0

Find out the discharge of water in the system. [Assume: pipe entrance is well rounded i.e. $r/D > 0.2$, $K_{\text{entrance}} = 0.03$, $K_{\text{bend}} = 0.35$, $K_{\text{exit}} = 1$] (10)

5. (a) What are the main principles behind the design procedure of looped network? (3)
- (b) What is a storage reservoir and why is it required in the distribution system? (4)
- (c) Calculate the flow in each of the pipes in the following looped pipe network (using Hardy Cross method and two trials are required): (13)

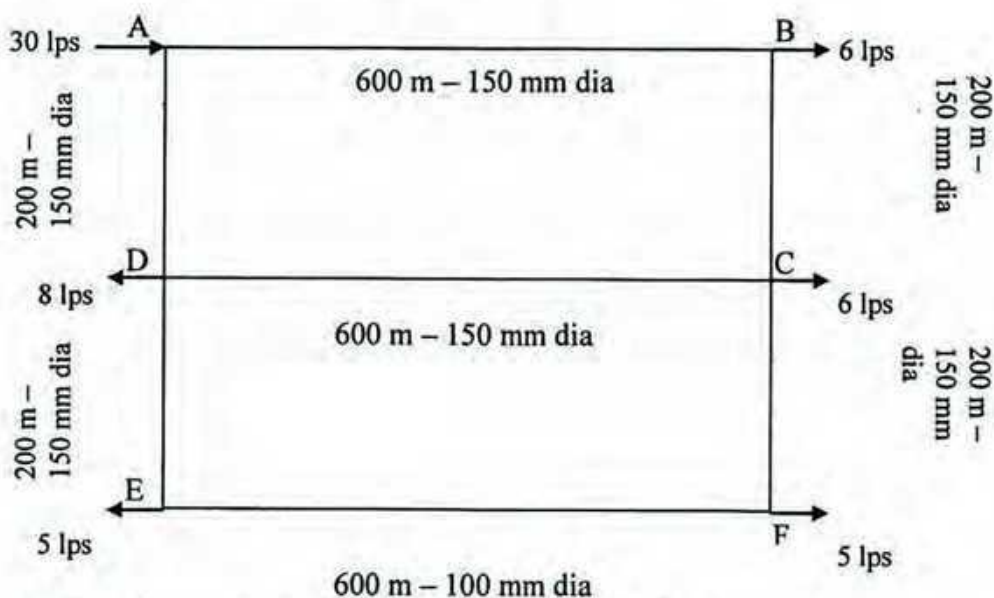

6. (a) What is the function of blank pipe at the bottom of the strainer? (4)

- (b) Design the appropriate details of a well following the given steps and according to the data provided below: (4 X 4 =16)

Sample Depth (ft)	D ₁₀	D ₃₀	D ₆₀	U = D ₆₀ / D ₁₀	FM	% Course Sand	% Medium Sand	% Fine Sand
170-210	0.12	0.195	0.3	2.50	1.26	3	67	30
210-220	0.15	0.21	0.33	2.20	1.41	4	70	26
220-270	0.17	0.28	0.3	1.76	1.63	6	77	17
270-310	0.17	0.28	0.31	1.82	1.69	11	72	17
310-370	0.17	0.24	0.38	2.24	1.5	5	75	20
370-410	0.17	0.29	0.395	2.32	1.63	5	80	15
410-430	0.15	0.22	0.37	2.47	1.47	5	71	24

- Find out the water bearing/most productive part of the aquifer (depth range) from the given grain size distribution summary at different depths showing suitable reasoning.
- Find out the length of the casing pipe, considering static water level at 250 ft, drawdown of 15 ft with water level declination of 2.5 ft per year, design life of 30 years and a safe distance of 10 ft. Assume, 80% of the aquifer screening can be made and find out the length of the strainer.
- Find out the yield from the well, if 40 slot strainer is used with the diameter of 4.5 inches. (Assume, the minimum permissible velocity of 0.1 fps and factor of safety of 2.0). What is the yield per day from the well, if it pumps water for 10 hours per day?
- If the well has to serve a community with 55,000 people with water demand of 40 liter per capita per day, how many wells will be required to be installed?
- Provide the well log in a schematic diagram. (BONUS MARKS = 3)

Useful Equations

$$t_d = V/Q$$

$$v_o = Q/A_s$$

$$P = 100 \frac{v_s}{v_o}$$

$$G = \sqrt{\frac{P}{uV}}$$

University of Asia Pacific
Department of Civil Engineering
Final Examination Fall 2014
Program: B.Sc. Engineering (Civil)

Course Title: Geotechnical Engineering I
Time: 3 hours

Course Code: CE 341
Full Marks: 100

Section A

There are 5 questions. Answer any 4 questions.

(4x13=52 marks)

1. (a) Briefly discuss on the significance of particle size distribution curve in coarse grained soil classification according to unified soil classification system. 3
(b) Derive the expression to calculate total flow-rate (per meter length) below the sheet pile wall, taking the advantage of flow-net. 5
(c) Determine compression index, swelling index coefficient of compressibility, coefficient of volume compressibility and coefficient of consolidation for the following records. 5
In a consolidation test, the pressure on a sample was increased from 150 to 300 kN/m². The void ratio after 100% consolidation under 150 kN/m² was 0.945 and that under 300 kN/m² was 0.812. The coefficient of permeability was 25x10⁻⁶ mm/s.

2. (a) Identify differences between consolidation and compaction. 3
(b) Derive the expression of settlement calculation for a clay soil, which was initially in normally consolidated state. 5
(c) Briefly discuss on the drainage conditions of three types of triaxial tests. 3
(d) Draw a typical Mohr circle presenting the data of unconfined compressive strength test. Show the relation between unconfined compressive strength and unconfined cohesion. 2

3. (a) Identify differences between standard Proctor test and modified Proctor test. 3
(b) Derive the expression of coefficient of passive earth pressure (K_p) for cohesionless soil. 5
(c) Draw typical shear stress vs shear displacement curve for loose and dense sand. 2
(d) Draw Mohr circles for at-rest, active and passive earth pressure conditions, and also the Mohr-Coulomb failure envelope. 3

4. (a) Estimate the energy delivered in standard proctor test. 3
(b) Compute OCR and pre-consolidation pressure at point A in the following timeline. The following data presents the stress-states of that points. 5
(a) In the year 2007, the soil, supporting a structure, was normally consolidated.
 $\sigma_{\text{present}}' = 450$ kPa.
(b) In 2010, the old structure was demolished. $\sigma_{\text{present}}' = 150$ kPa.
(c) In January 2011, new construction commenced. $\sigma_{\text{present}}' = 240$ kPa.
(d) In 2014, due to progress of the construction project, $\sigma_{\text{present}}' = 480$ kPa.
(c) Calculate the maximum dry density of the soil having 2.13 g/cm³ bulk density at optimum moisture content. From a laboratory compaction test on a sample of the soil, the optimum moisture content is found to be 14.28%. 5
Also calculate the dry density at optimum moisture content for zero air void condition.

5. (a) Define 'Relative Density'. Derive the expression to calculate field relative density. 3
 (b) Write Bernoulli's equation and Darcy's law for a soil media. 2
 (c) Derive the expression of coefficient of permeability for fine grained soil. Mention the name of the permeameter used in the laboratory for this purpose. 3
 (d) Briefly discuss on the following for fine grained soil: 5
 (i) Index properties
 (ii) Soil structure

Section B

There are seven questions. Answer any 6 questions.

(6x8 = 48 marks)

6. A concrete gravity dam, 150 m long and 90 m wide, lies on a permeable soil with a coefficient of permeability of 30×10^{-3} mm/s. The head of water is maintained at 30 mm upstream and zero at the tail-end. The soil is underlain by an impervious stratum. A flownet is constructed for this condition which yielded 8 flow lines and 16 equipotential drops. 8
 (i) Calculate the seepage loss per day (flow rate) under the dam, considering a two-dimensional flow.
 (ii) Plot the distribution of the uplift pressure on the base of the dam.
7. A total load of 900 kN is uniformly distributed over a rectangular footing of size 2m x 3m. Find the vertical stress at a depth of 2.5 m below the point A. If another footing size 1m x 3m with a total load of 450 kN is constructed adjoining the previous footing, what is the additional vertical stress at the same point below A due to the construction of the second footing. 8

Influence chart for vertical stress below corner of rectangular load is attached.

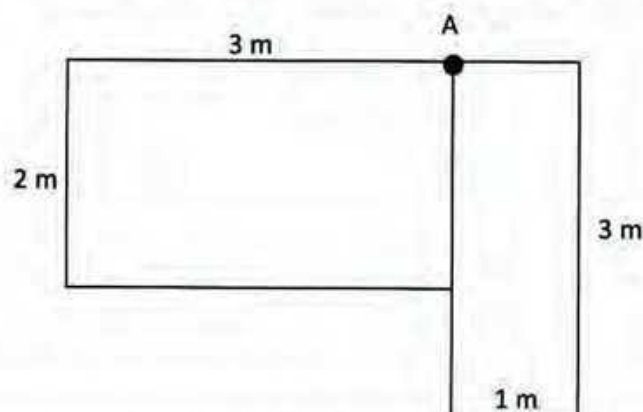

For $m=1.2$

n	0.2	0.3	0.4	0.5	0.6	0.7	0.8
Influence factor, I	0.05733	0.083	0.106	0.126	0.143	0.157	0.168

8. Classify the following soils:
- (a) Percent finer than 0.075 mm = 52 4
 Percent of coarse fraction passing 4.75 mm sieve = 62
 Liquid limit = 35%
 Plastic limit = 25%
- (b) Percent of soil material in the pan = 3.5 4
 Percent of coarse fraction passing 4.75 mm sieve = 60
 30% of the total soil material having a diameter less than 1.18 mm
 10% of the total soil material having a diameter less than 0.3 mm
 Liquid limit = 33%
 Plastic limit = 33%
9. Draw the lateral earth pressure diagrams for both the active and passive conditions for the following backfill soil. 8

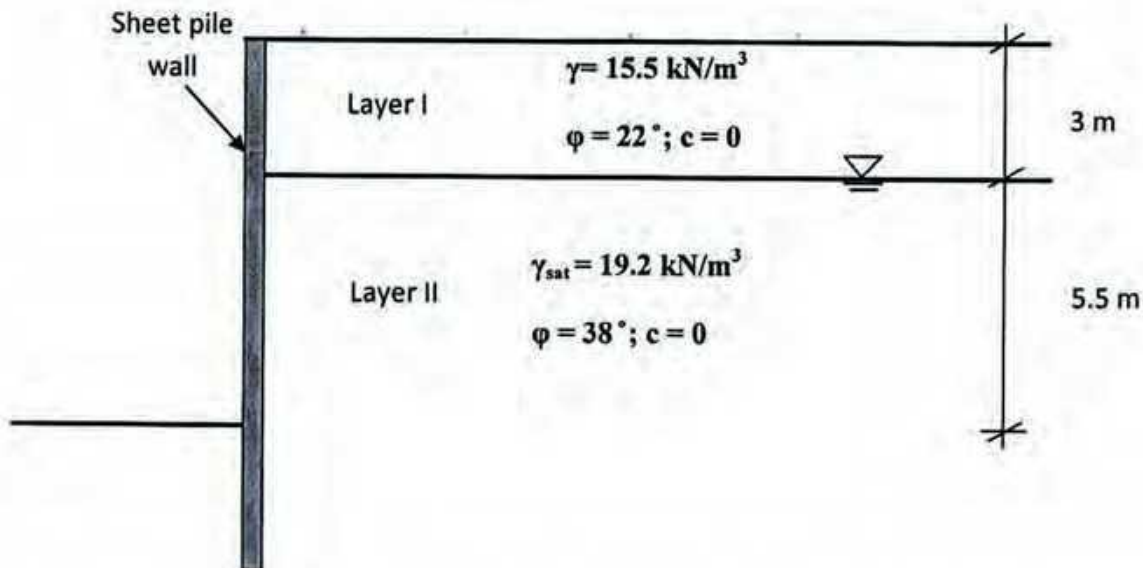

10. A 6 m thick saturated clay layer has a compression index of 0.28. At a stress of 120 kN/m^2 the void ratio was 1.02. Calculate the void ratio if the stress on soil is increased to 180 kN/m^2 . Also calculate the primary consolidation settlement for each of the following cases: 8
- (i) Pre-consolidation pressure = 120 kN/m^2
 (ii) Pre-consolidation pressure = 220 kN/m^2
 (iii) Pre-consolidation pressure = 150 kN/m^2
11. If the shear box is 60 mm square and the proving ring constant is 20 N per division, estimate the shear strength parameters of the soil. 8
 Would failure occur on a plane within this soil at a point where the normal stress is 320

kN/m^2 and the corresponding shear stress is 138 kN/m^2 ?

The following results were obtained from a direct shear test on a sandy clay sample:

Normal load (N)	Shear load proving ring reading (division)
360	13
720	19
1080	26
1440	26

12. Triaxial compression tests were conducted on a specimen. All tests were run slowly, permitting complete drainage. Determine shear strength parameters for the given soil.

8

Deviator stress at failure (kN/m^2)	Confining pressure (kN/m^2)
331	481
155	231
133	131
119	53

University of Asia Pacific
Department of Civil Engineering
Final Examination Fall 2014
Program: B.Sc. Engineering (Civil)

Course Title: Open Channel flow
Time: 3 Hours

Course Code: CE 361
Full Marks: 150

All notations are having usual meaning. Assume any reasonable data, if not given

Section A

Answer any 3 (Three) out of 4 (Four) questions

1. (a) What do you mean by uniform flow? What are the conditions imply for uniform flow? (05)
- (b) Write down the relationship between Chezy's C, Darcy-Weisbach friction factor f and Manning's n. (05)
- (c) A circular channel 2 m in diameter is laid on a slope of 0.001 and carries a discharge of 4 m³/s. Compute the normal depth and velocity when n= 0.013. (15)
2. (a) What do you mean by best hydraulic section? Compare between the non-silting and the non-scouring velocity. (09)
- (b) Design a stable alluvial channel using the Lacey's theory. The channel is to carry 10 m³/s and having mean sediment size 1 mm. (16)
3. (a) What is hydraulic jump? Describe the types of jump occurs in open channel flow. (09)
- (b) A hydraulic jump occurred in a horizontal rectangular channel of 6 m wide and 0.52 m depth. The length of the jump is found 29.56 m. Determine
 - i. Type of jump
 - ii. Efficiency of the jump
 - iii. Relative height of the jump(16)
4. (a) Write short notes on laminar viscous sublayer and section factor of a channel (06)
- (b) Prove that in a critical flow Froude number is equal to unity. (06)
- (c) What is shear stress? Derive an expression of drag velocity of a channel. (13)

Section B

Answer any 3 (Three) out of 4 (Four) questions

5. (a) Write some factors affecting Manning's n . (05)
- (b) Water flows in open channel at a depth of 1 m and a mean velocity of 3 m/s. (20)
Compute the discharge and determine the state of flow if the channel is
- i. Wide
- ii. Triangular with $s=2$
- If elementary waves are created in these channels, determine the speeds of the wave fronts upstream and downstream.
6. (a) Write short notes on Momentum equation. (05)
- (b) Write down the practical applications of hydraulic jump. (05)
- (c) For a trapezoidal channel with $b=6\text{m}$ and $s=2$, compute the critical depth by the Newton-Raphson method if $Q=14\text{ m}^3/\text{s}$ and $\alpha=1$. (15)
7. (a) Prove that conveyance computed by Manning equation for triangular section is 5.33. (05)
- (b) Show that best hydraulic rectangular section is one half of a square. (05)
- (c) Compute the hydraulic exponent for uniform flow computation N of a trapezoidal channel with $b=6.1\text{ m}$, $s=2$ and $h=2\text{ m}$ based on the Chezy's formula. (15)
8. (a) Write short notes on Jumps in sloping channel with classifications. (09)
- (b) A rectangular channel is 1 m wide and inclined at an angle of 3.5° with the horizontal. Determine the type of jump when the discharge is $0.15\text{ m}^3/\text{s}$, the initial depth of flow section is 0.02 m and the tail water depth is found 0.70m. Also compute the energy loss in the jump if the length of the jump is 2 m. (16)

University of Asia Pacific
Department of Civil Engineering
Final Examination Fall 2014
Program: B. Sc. Engineering (Civil)

Course Title: Structural Engineering II
 Time: 3 hours

Course Code: CE 313
 Full Marks: 10×10 = 100

[Answer any 10 (ten) of the following 14 (fourteen) questions]

(Symbols have their usual meanings)

1. For the 2-storied frame loaded as shown in *Fig.1*, (i) Use the Portal Method to determine the value of applied forces F_1 and F_2 if shear in beam ab and cd is -3.33 k and -8.33 k respectively, (ii) Also draw the BMD of the beams and the columns.

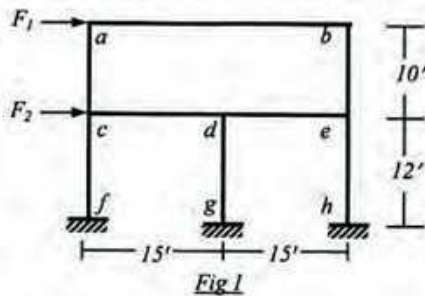

Fig.1

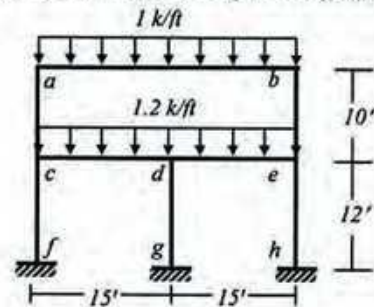

Fig.2

2. For the 2-storied frame loaded as shown in *Fig.1*, use Cantilever Method to draw the AFD of the columns when, $F_1 = 12$ k and $F_2 = 20$ k. Assume all column areas are equal.
3. For the 2-storied frame structure loaded as shown in *Fig.2*, use the approximate location of hinges to draw the SFD and BMD of the beams and columns.
4. Calculate the vertical deflection at point b of the beam shown in *Fig.3*, using Virtual Work Method [Given: $EI = 40,000$ k-ft²].

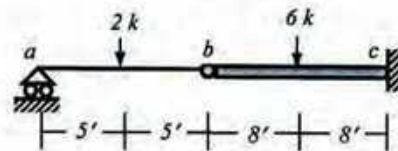

Fig.3

5. For the truss shown in *Fig.4*, use Virtual Work Method to calculate the vertical deflection of the point f due to the external loads applied [Given: $EA/L = 500$ kip/ft, for all the truss members].
6. Use the Virtual Work Method to calculate the vertical deflection at point a of the frame shown in *Fig.5* [Given: $EA = 400 \times 10^3$ k, $GA^* = 125 \times 10^3$ k, $EI = 40 \times 10^3$ k-ft²].

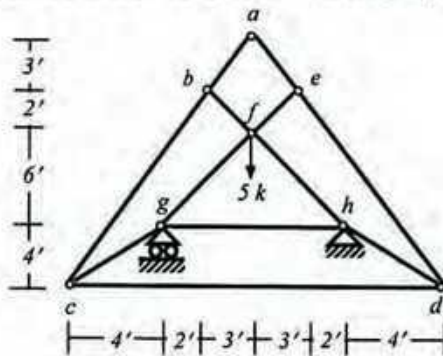

Fig.4

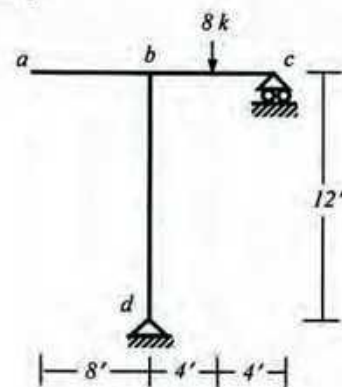
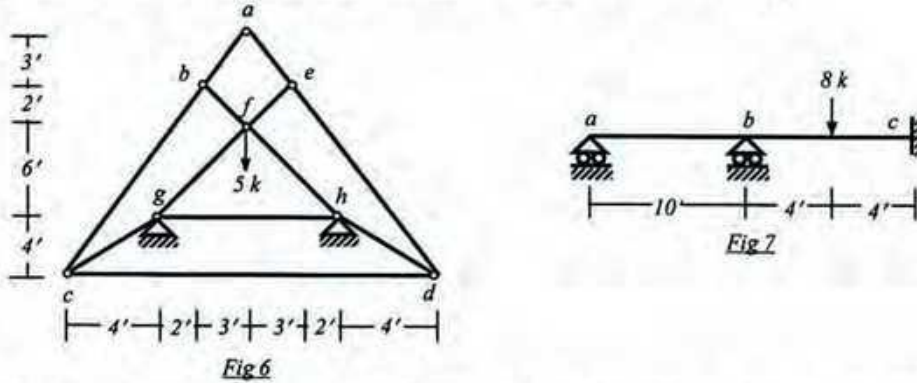

Fig.5

7. Use the Flexibility Method to calculate the member forces of the truss shown in *Fig.6*, if in addition to the applied load, support *g* moves 0.10' leftward [Given: $EA/L = 1000$ kips/ft].



8. Use the Flexibility Method (considering flexural deformation only) to draw the bending moment diagram of the beam shown below, if in addition to the applied load, support *a* settles 0.10' downward [Given: $EI = 40 \times 10^3$ k-ft²].

9. Using Flexibility Method, draw the bending moment diagram of the frame shown in *Fig.8* [Given: $EA = 400 \times 10^3$ k, $GA^* = 125 \times 10^3$ k, $EI = 40 \times 10^3$ k-ft²].

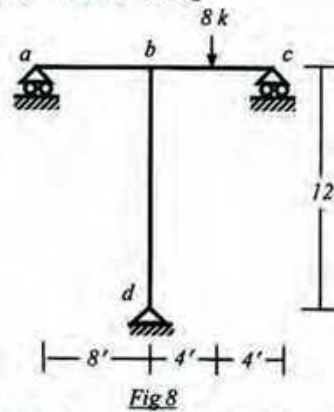

10. Use the Moment Distribution Method to calculate the joint moments and draw bending moment diagram of the beam shown in *Fig.9* [Given: $EI_{ab} = EI_{cd} = 2EI$, $EI_{bc} = EI$].

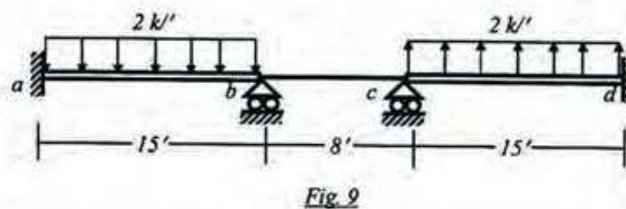

11. Use the Moment Distribution Method to calculate the joint moments and draw bending moment diagram of the frame shown in *Fig.10* [Given: $EI = \text{Constant}$].

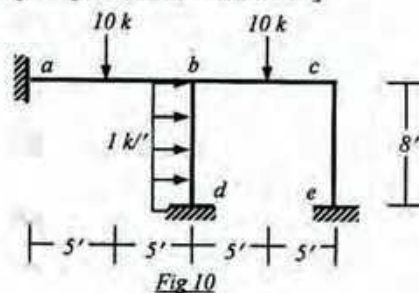

12. Use Moment Distribution Method to calculate the joint moments and draw bending moment diagram of the beam shown in *Fig.11*, if support *c* moves 0.1 ft upward and support *d* rotates 0.04 rad clockwise [Given: $EI = 2000 \text{ k-ft}^2$].

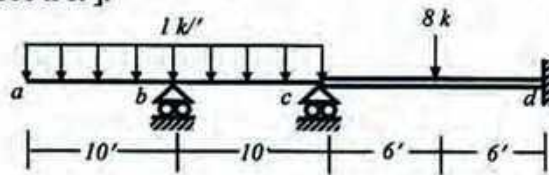
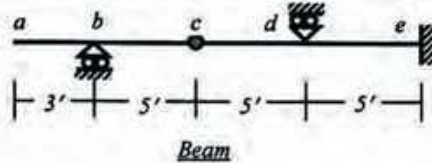

Fig.11

13. Draw the Qualitative Influence lines for the indeterminate structures shown in *Fig.12*

- (i) $R_b, R_d, V_{d(L)}, V_{d(R)}, M_e$ for the beam
 (ii) $R_{c(y)}, R_{e(x)}, V_g, M_g, M_a$ for the frame



Beam

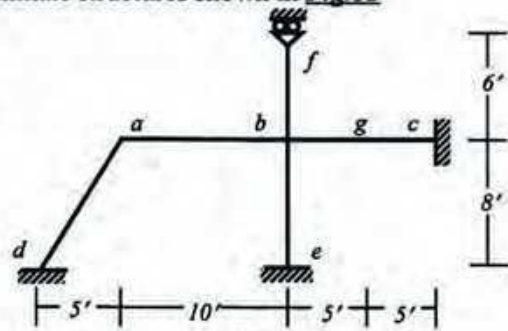

Fig.12

Frame

14. For the beam shown in *Fig.13* calculate the maximum positive value of M_e , if the beam is subjected to a uniformly distributed DL = 1.5 k/ft and moving LL = 0.5 k/ft (uniformly distributed) and 3 k (concentrated) [Given: $EI = \text{Constant}$].

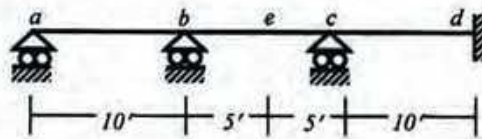

Fig.13

University of Asia Pacific
Department of Civil Engineering
Final Examination Fall 2014
Program: B.Sc. Engineering (Civil)

Course Title: Design of Concrete Structures II
 Time: 3.0 hr

Course Code: CE 317
 Full Marks: 100

Part A

[Answer any five (05) out of following Seven (07) questions]

Full Marks: 25 [=5*(5)]

1. State the limitations of Direct Design Method (DDM) for two way slabs.
2. What is punching shear failure? Discuss the design options to prevent punching shear failure with neat diagram.
3. What is pre-stressed concrete? Discuss the advantages and types of pre-stressed concrete.
4. What kind of failure may occur in a retaining wall? Draw different types of Retaining wall.
5. What is short column? Mention and justify the maximum and minimum steel ratios specified by ACI for RC columns
6. Explain why transverse reinforcements are used in RC columns.
7. Mention different types of RC foundations and also mention when they are used.

Part B

[Answer any Five (05) out of following eight (08) questions]

Full Marks: 75 [=5*15]

[Given: $f_c' = 3$ ksi, $f_y = 60$ ksi, $f_{call} = 1.35$ ksi, $f_{sall} = 30$, ksi for all questions]

[Assume reasonable values for any missing data]

All symbols have their usual meanings

8. A floor system of panel 25' by 18' consists of solid slab and beams (Section A-A) shown below. The floor system is supported by column 18 x 18 in² columns. Determine the following for interior panel
 - a) Determine I_{beam} and I_{slab}
 - b) Determine α_{long} and α_{short}
 - c) Determine minimum slab thickness required

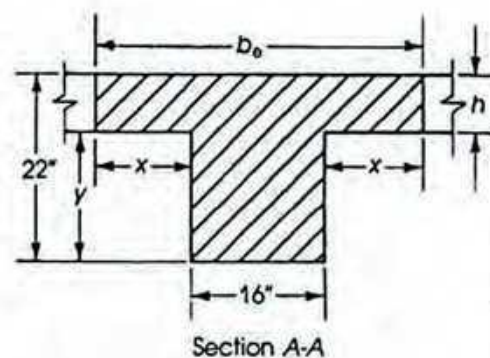
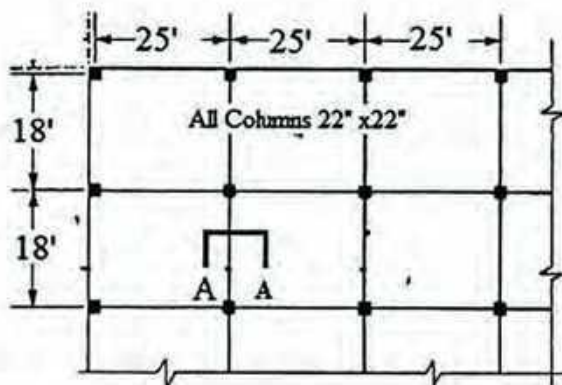

9. A flat slab system with column of 22 x 22 inch² is shown below. The slab contains floor finish of 35 psf, random wall = 50 psf and live load = 75 psf. Determine the following for Slab 3 in USD : (Use DL and LL factor 1.4 and 1.7 respectively)

- Co-efficient $C_{a(D)+}$, $C_{a(L)+}$, C_{a-} , $C_{b(D)+}$, $C_{b(L)+}$, C_{b-}
- Moments, M_{a+} , M_{b+} , M_{a-} , M_{b-}
- Reinforcement required, A_{sa+} , A_{sa-} , A_{sb+} , A_{sb-}
- Draw reinforcement diagram in a neat figure

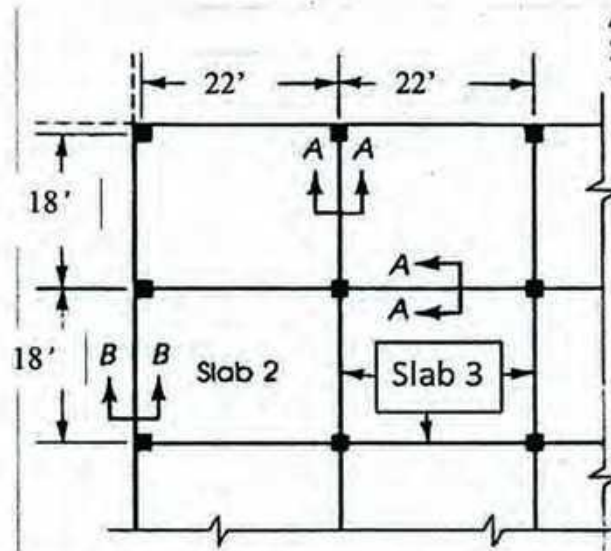

10. A flat plate floor has thickness $h=8.5''$ and is supported by 20" columns spaced 20ft on centres each way. The floor will carry a total factored load of 300 psf. Check the adequacy of the slab in resisting punching shear at a typical interior column and provide shear at a typical interior column and provide shear reinforcement using bent bars. (Use WSD method, $V_c = 1.1\sqrt{f'_c}b_0d$ and $V_s = (V_u - \phi V_c)/\phi$)

11. Use USD method to design the footing for the 14"-thick brick wall supporting RC slabs shown below (in a 7-storied building with 12'-high stories), if they carry loads including FF = 40 psf, RW = 55 psf and LL = 40 psf [Given: Depth of footing = 5 ft, Allowable soil bearing pressure = 4 ksf,]

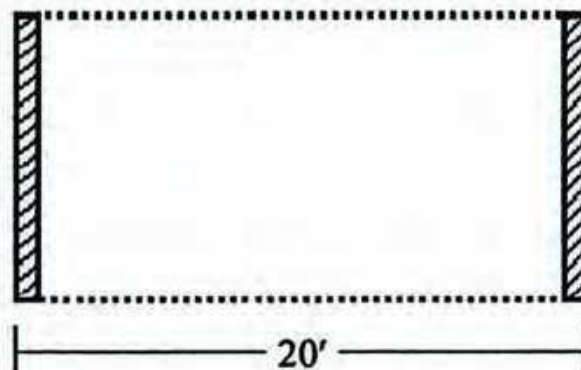

12. Figure below shows the working loads (half DL, half LL), arrangement of 12"×12" columns C_1 , C_2 , C_3 and boundaries of other footings (firm lines for property lines and dotted lines for adjacent footing boundaries, Allowable soil bearing pressure = 2.0 ksf).

- What type of footing can be provided in this area? Why?
- Determine required thickness of the footing from shear and moment diagram (WSD)

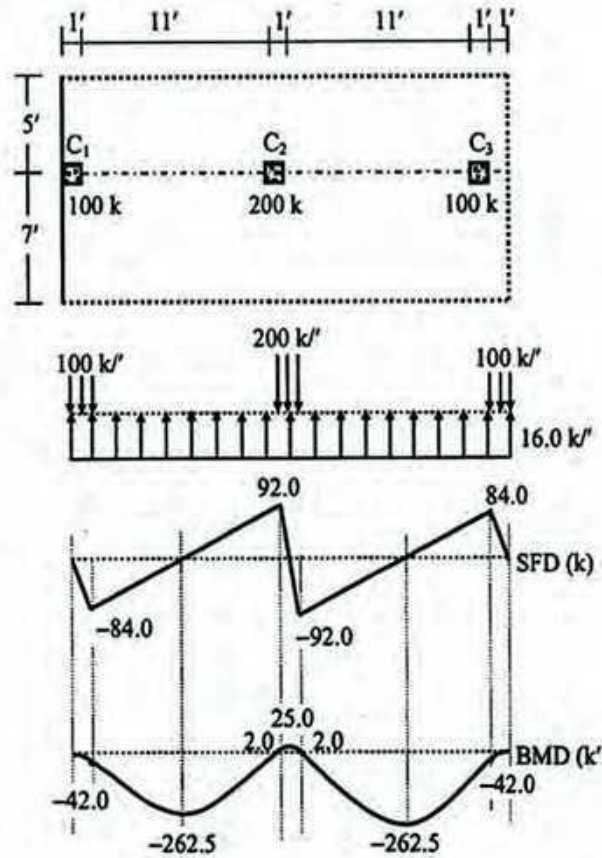

13. A gravity wall is to retain a bank 11.5ft high whose horizontal surface is subject to a live load surcharge of 500psf. The soil is a stiff clay and the allowable bearing capacity is 8500psf. Determine whether the retaining wall designed below is safe against overturning

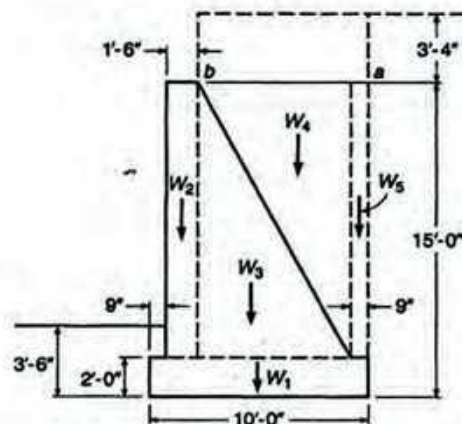

14. (a) Determine suitable tie arrangements (with spacing) for the following column sections in figure below, as per ACI Code

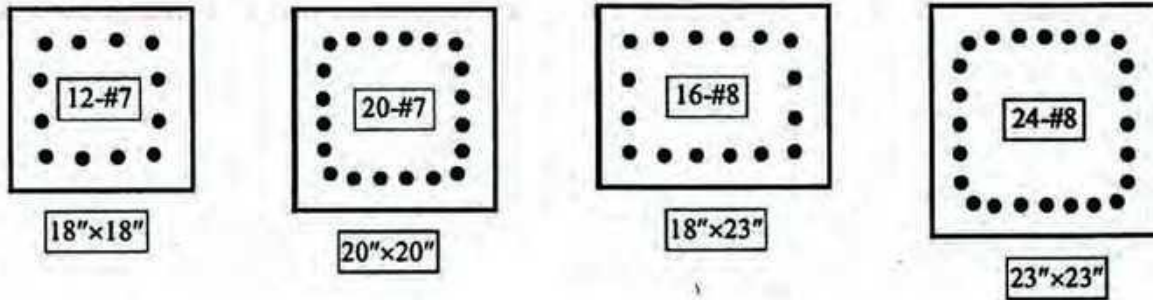

(b) Calculate the required spacing of spiral reinforcements for circular column sections of

i) 18"-dia, (ii) 30"-dia, with $d_{core} = d_{col} - 3"$

12. For the column section shown, select reinforcing bars. Take $P_D = 125k$, $P_L = 140k$, $M_D = 75k\text{-ft}$, $M_L = 90k\text{-ft}$. Assume section is compression controlled.

(Only for this problem, use $f'_c = 4\text{ ksi}$, $f_y = 60\text{ ksi}$ and take $\phi = 0.7$, for tied column)

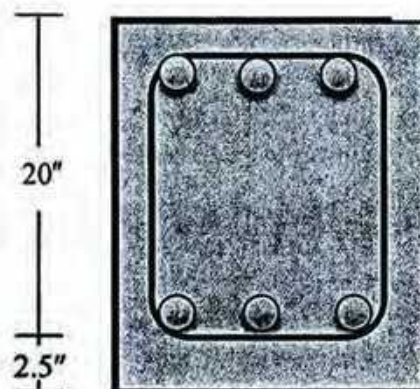

Formula Sheet

(a) For $0.2 \leq \alpha_m \leq 2$

$$h = \frac{I_u \left(0.8 + \frac{f_y}{200,000} \right)}{36 + 5\beta(\alpha_m - 0.2)}$$

f_y in psi. But not less than 5 in.

(b) For $2 < \alpha_m$

$$h = \frac{I_u \left(0.8 + \frac{f_y}{200,000} \right)}{36 + 9\beta}$$

f_y in psi. But not less than 3.5 in.

$$\alpha = \frac{4E_{cb}I_b/l}{4E_{cs}I_s/l} = \frac{E_{cb}I_b}{E_{cs}I_s}$$

E_{cb} = Modulus of elasticity of beam concrete

E_{cs} = Modulus of elasticity of slab concrete

I_b = Moment of inertia of uncracked beam

I_s = Moment of inertia of uncracked slab

note

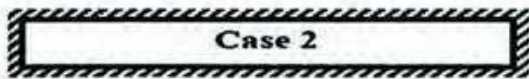
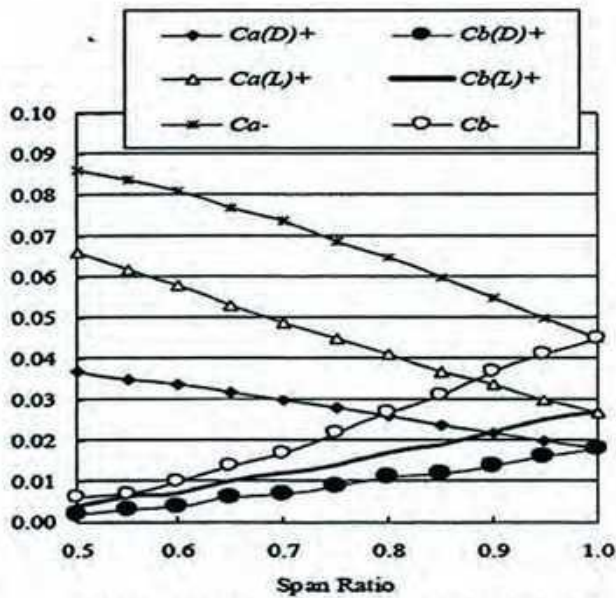
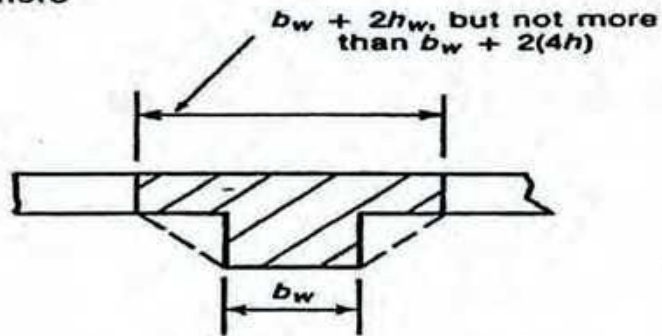

$$\begin{aligned} * -M_A &= C_{A-} \times W_T \times A^2, & * -M_B &= C_{B-} \times W_T \times B^2 \\ * +M_A &= C_{A(d)} \times W_{DL} \times A^2 + C_{A(LL)} \times W_{LL} \times A^2, \\ * +M_B &= C_{B(d)} \times W_{DL} \times B^2 + C_{B(LL)} \times W_{LL} \times B^2 \end{aligned}$$

$$A_s = (f_c / f_y) [1 - \sqrt{1 - 2 M_n / (f_c b d^2)}}] b d$$

$$f_c = 0.85 f_c'$$

$$A_s(\text{Temp}) = 0.0030 b t$$

Design Table For Wall footing

Parameter	Equation
w_{slab} (psf)	$SW + FF + RW + LL$
w_{wall} (lb/ft)	$t_{wall} \times h_{wall} \times \gamma_{wall}$
w_f (k/ft)	$N (w_{slab}L/2 + w_{wall})$
q_{net} (ksf)	w_{wall}/B
V_{max} (k/ft)	$q_{net} \{ (B - t_{wall})/2 - d \}$
v_{max} (ksi)	V_{max}/bd
d_{reqd} (")	$v_{max} = v_c$
M_{max} (k-ft)	$q_{net} \{ (B - t_{wall})/2 \}^2/2$
d_{reqm} (")	$\sqrt{(M_{max}/Rb)}$
d (")	$\geq d_{reqd}$
t (")	$d + 3.5$
A_s (in ² /ft)	$M_{max}/(f_{sall}jd)$, OR $0.85f_c'f_y[1 - \sqrt{(1 - 2M_u/(0.85f_c'bd^2))}]bd$
A_{st} (in ² /ft)	$0.003bt$
L_d (")	$0.020 f_y \sqrt{f_c'} d_b$ [Anchored]

For USD, $\rho_b = 87/(87 + f_y) (\alpha f_c'/f_y)$
 $\Rightarrow R_u = \phi \rho_{max} f_y (1 - 0.59 \rho_{max} f_y/f_c')$
 Also $v_{cu} = 2\phi \sqrt{f_c'}$ $\rho_{max} = 0.75 \rho_b$

Design Table For Combined footing

Parameter	Equation
V_p (k)	$P_c - q_{net} (c_1 + d) (c_2 + d)$
A_p (in ²)	$2(c_1 + d + c_2 + d)d$ OR $\{2(c_1 + d) + c_2 + d\}d$
Equation	$V_p/A_p = v_p$
d_{reqp} (")	$V_p/A_p = v_p$
V_f (k)	$V_{max} - w_{net} d$
v_f (ksi)	V_f/bd
d_{reqs} (")	$v_f = v_c$
M_{max} (k')	From BMD
d_{reqm} (")	$\sqrt{(M_{max}/Rb)}$
w_{ibm} (k/ft)	$P_{c2}/B, P_{c1}/B$
M_{ibm} (k')	$w_{ibm}L^2/2$
d_{reqt} (")	$\sqrt{(M_{ibm}/Rb)}$

TABLE 17.1

Unit weights w , effective angles of internal friction ϕ , and coefficients of friction with concrete f

Soil	Unit Weight w , pcf	ϕ , deg	f
1. Sand or gravel without fine particles, highly permeable	110-120	33-40	0.5-0.6
2. Sand or gravel with silt mixture, low permeability	120-130	25-35	0.4-0.5
3. Silty sand, sand and gravel with high clay content	110-120	23-30	0.3-0.4
4. Medium or stiff clay	100-120	25-35 ^a	0.2-0.4
5. Soft clay, silt	90-110	20-25 ^a	0.2-0.3

^a For saturated conditions, ϕ for clays and silts may be close to zero.

Co-efficient of active earth pressure = $K_{ah} = \frac{1 - \sin \phi}{1 + \sin \phi}$

Co-efficient of Passive earth pressure = $K_{ph} = \frac{1 + \sin \phi}{1 - \sin \phi}$

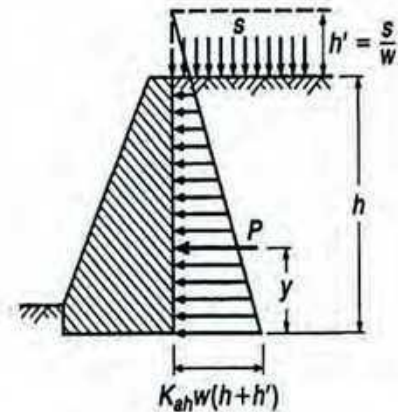

$y = \frac{h^2 + 3hh'}{3(h + 2h')}$

$P = \frac{1}{2} K_{ah} w h (h + 2h')$

Minimum ratio of spiral reinforcement $\Rightarrow \rho_s = 0.45(A_g/A_{core} - 1)(f_c'/f_y) =$

Spacing of spiral reinforcement $S = 4A_{sp}/(\rho_s d_{core})$

University of Asia Pacific
Department of Civil Engineering
Final Examination Fall 2014
Program: B.Sc. Engineering (Civil)

Course Title: Environmental Engineering II

Course Code: CE 333

Time: 3.0 hours

Full Marks: 150 (=6×25)

[ANSWER ALL PARTS (i.e. a, b) OF EACH QUESTION TOGETHER]

[Assume reasonable values for any missing data]

SECTION –A

[Answer any 3 (Three) of the following 4 (Four) questions]

1. (a) What are the technical advantages of SBS over conventional sewerage system? (8)
What are the advantages of combined and separate sewerage systems? (5)
- (b) A Residential area of 20 ha, has a total of 50 nos 6 storied buildings with two flats on each floor. The average occupancy is 6 persons per flat. The per capita water demand is 210 liter per day. (12)
- The area has the following surface characteristics:
- The average area of the roof is 60 m²/building, with runoff coefficient of 0.9.
 - The roads occupy 30% of total area. Impermeability factor for these roads could be taken as 0.6.
 - The remaining area is open space whose coefficient of runoff may be taken as 0.12.
- (i) For a rainfall with 50 minutes duration and 20-year return interval, what will be the storm discharge from the area?
- (ii) Also find the wet weather flow from the area.
2. (a) What are the advantages of pour-flush technologies over simple pit latrine? (5)
- (b) In a 10 unit apartment building, 50 residents are generating an average wastewater flow of 160 lpcd. Design a double chamber septic tank for the building that will be desludged at every 3 years. For ensuring better effluent quality, it is recommended that the minimum hydraulic retention time for the tank be 1.0 day. Due to space constraints, specific tank area has to be restricted within 12 m². Assume wastewater temperature within the tank to be 25°C. Check clear space depth. Draw a net sketch showing details of septic tank dimensions and depth of different zones. (20)
3. (a) Draw typical bacterial growth pattern and indicate different phases. (4)
Which phase of bacterial growth is important for sewage treatment and why? (3)
Explain the relation between food/microorganism ratio and biomass settling characteristics with figure. (6)

- (b) What are the objectives of sewage treatment? (5)
Briefly describe the unit operations in sewage treatment processes. (7)
4. (a) Write down the composition of a typical waste water sample. (5)
Briefly explain the significance of – (i) color, (ii) solid content and (iii) temperature of sewage in sewage treatment. (6)
- (b) What are the basic differences between suspended and attached growth processes? Give examples of these treatment processes. (6)
Calculate the effluent BOD from a trickling filter having a depth of 1.5 m and a recirculation rate of 110 percent of the flow. The influent BOD is 150 mg/L following primary treatment. Laboratory determined value of k is 0.21. (8)
Also calculate the BOD removal efficiency of the filter. What adjustment should be made in the recycling ratio to increase the BOD removal efficiency?

SECTION –B

[Answer any 3 (Three) of the following 4 (Four) questions]

5. (a) What are the basic functional elements of the conventional sewerage system? (5)
What are the suitable conditions for combined and separate sewerage system? (5)
- (b) A drainage area, having rain falls during five months of the year only, has an area of 25 ha, with 40 residential buildings/ha and 10 commercial buildings. The area has the following surface characteristics: (15)
- (i) The average roof area are 50 m²/ residential building and 20 m²/commercial building. Here, the runoff coefficient is 0.85 for both types of buildings.
(ii) The roads occupy 30% of the total area. Impermeability factor for these roads could be taken as 0.75.
(iii) The remaining area is open space whose coefficient of runoff may be taken as 0.10.
- If the rainfall records show that the intensity of an ordinary rainstorm is 5 cm/h, what will be the discharge from this district?
- Determine the dry weather flow from the area if the population is 400 persons/ha and the rate of water supply is 240 lpcd.
- Also find the ratio of storm sewage flow to dry weather flow and indicate the suitability of separate sewerage scheme in the area in preference to combined sewerage scheme.
6. (a) Which type of bacteria is important for aerobic treatment of sewage? (2)
Briefly describe the role of bacteria in sewage treatment. (6)
What are the purposes of secondary treatment process? (3)
- (b) Classify bacteria according to metabolism. Also mention their carbon and energy sources. (4)
Briefly explain the metabolism of bacteria with relevant equations. (3)
What are the advantages and disadvantages of waste stabilization ponds? (7)

7. (a) Briefly explain – (i) Black water, (ii) Grey water, (iii) Building sewer, (iv) Lateral sewer and (v) Trunk sewer. (10)
- (b) Using the enclosed nomogram (Fig. 3) and relevant equations, determine the maximum permissible and minimum required discharge in a 30 cm circular concrete pipe with Manning's roughness coefficient of 0.013. The self-cleansing and non-scouring velocities in a concrete pipe are 0.6 m/s and 3 m/s respectively. Also find the required slopes of the pipe to maintain self-cleansing and non-scouring velocities respectively. Now, if the pipe is laid on a slope of 0.03 and flowing half full, what will be the discharge and velocity through the pipe. Use the hydraulic elements diagram in Fig. 2. (15)
8. (a) What are the functions of aeration in activated sludge process? (3)
Explain the significance of high F/M ratio and low F/M ratio in activated sludge process. (6)
- (b) Design a waste stabilization pond system to treat 1500 m³/d of domestic sewage with a BOD contribution of 350 mg/l. The mean temperature of the coolest month is 22°C and 28°C during irrigation season. It is desired that the final effluent can be used for crop irrigation. Assume faecal coliform concentration in raw waste water to be 1×10⁸ per 100 ml. The required effluent standards are FC < 1000 per 100 ml. Assume k and k_b as 0.23 d⁻¹ and 2.6 d⁻¹ respectively at 20 °C. (16)

Formulae:

$$C_e = \left(\frac{C_i + rC_e}{1+r} \right) e^{-kD}$$

$$V_{sc} = 0.4 V_{slb} \quad t_h = 1.5 - 0.3 \log(Pq), \quad V_h = 10^{-3} P q t_h$$

$$t_d = 30(1.035)^{35-T}, \quad V_d = 0.5 \times 10^{-3} P t_d, \quad V_{sl} = C \times P \times N, \quad d_{sc} = 0.82 - 0.26A$$

$$Q = FCIA$$

$$\lambda_v = L_i Q / V_a, \quad \lambda_s = 10 L_i Q / A, \quad Q = V/t$$

$$N_e = \frac{N_i}{1 + k_b t}, \quad N_e = \frac{N_i}{(1 + k_b t_a) \times (1 + k_b t_f) \times (1 + k_b t_m)^x}, \quad t_{m1} = 10 L_i D_m / \lambda_s$$

$$t_m = \{ [N_i / N_e (1 + k_b t_a) (1 + k_b t_f)]^{1/n} - 1 \} / k_b$$

$$k_{b(T^{\circ}C)} = k_{b(20^{\circ}C)} \times (1.19)^{T-20}, \quad k_{(T^{\circ}C)} = k_{(20^{\circ}C)} \times (1.05)^{T-20}$$

$$Q = AV, \quad V = 1.486(R^{2/3}S^{1/2})/n, \quad R = D/4, \quad D = (2.16Qn/\sqrt{S})^{3/8}$$

Table 1: Design values of λ_v and BOD removal rate at various temperatures

Temperature ($^{\circ}$ C)	Volumetric Loading Rate, λ_v ($\text{g}/\text{m}^3 \text{ d}$)	BOD removal (%)
≤ 10	100	40
11	120	42
12	140	44
13	160	46
14	180	48
15	200	50
16	220	52
17	240	54
18	260	56
19	280	58
20	300	60
21	300	62
22	300	64
23	300	66
24	300	68
≥ 25	300	70

Table 2: Design values for surface BOD loading rates for facultative ponds at various temperatures

Temperature ($^{\circ}$ C)	Surface loading rate, λ_s (kg/ha d)	Temperature ($^{\circ}$ C)	Surface loading rate, λ_s (kg/ha d)
10	100	20	253
11	112	21	272
12	124	22	292
13	137	23	311
14	152	24	331
15	167	25	350
16	183	26	369
17	199	27	389
18	217	28	406
19	235	29	424

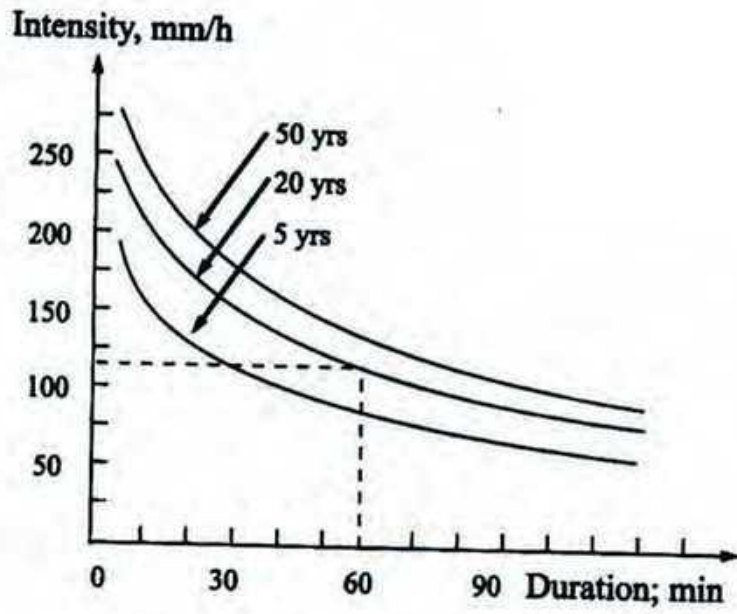

Figure 1: Rainfall Intensity-Duration-Frequency Curves

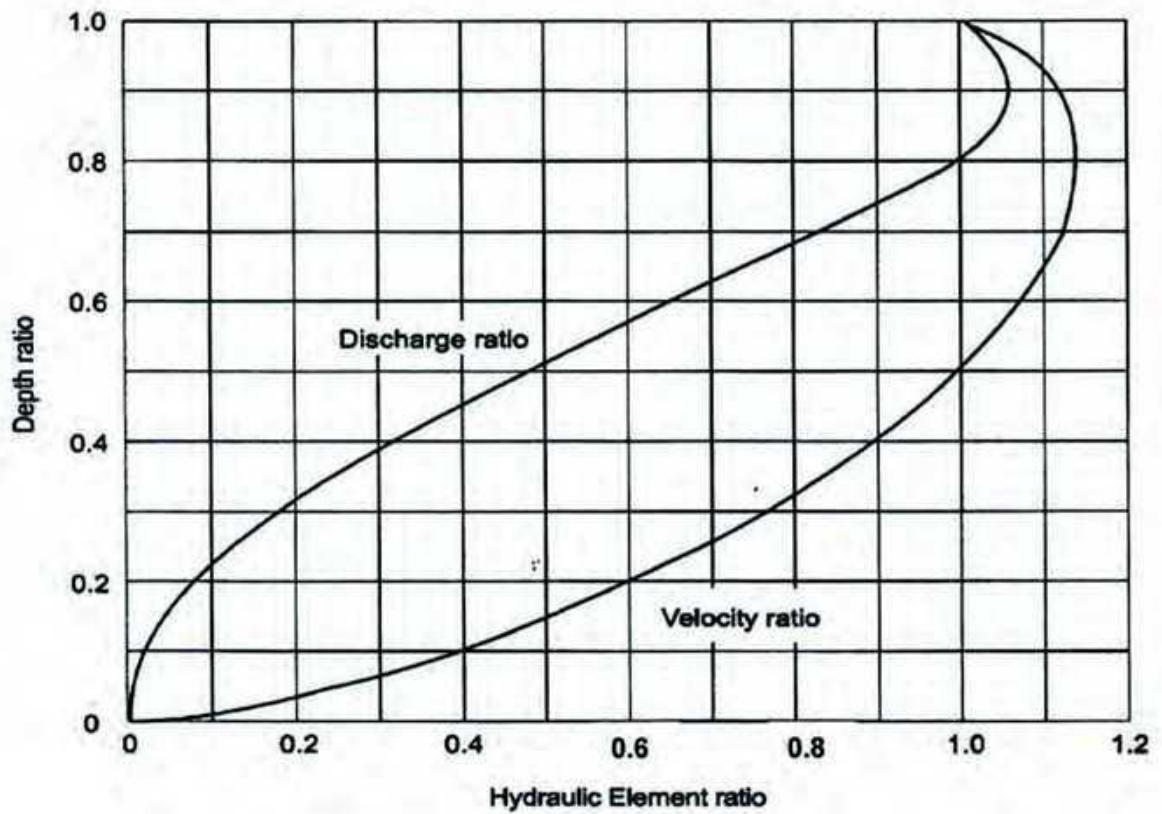

Figure 2: Hydraulic elements diagram

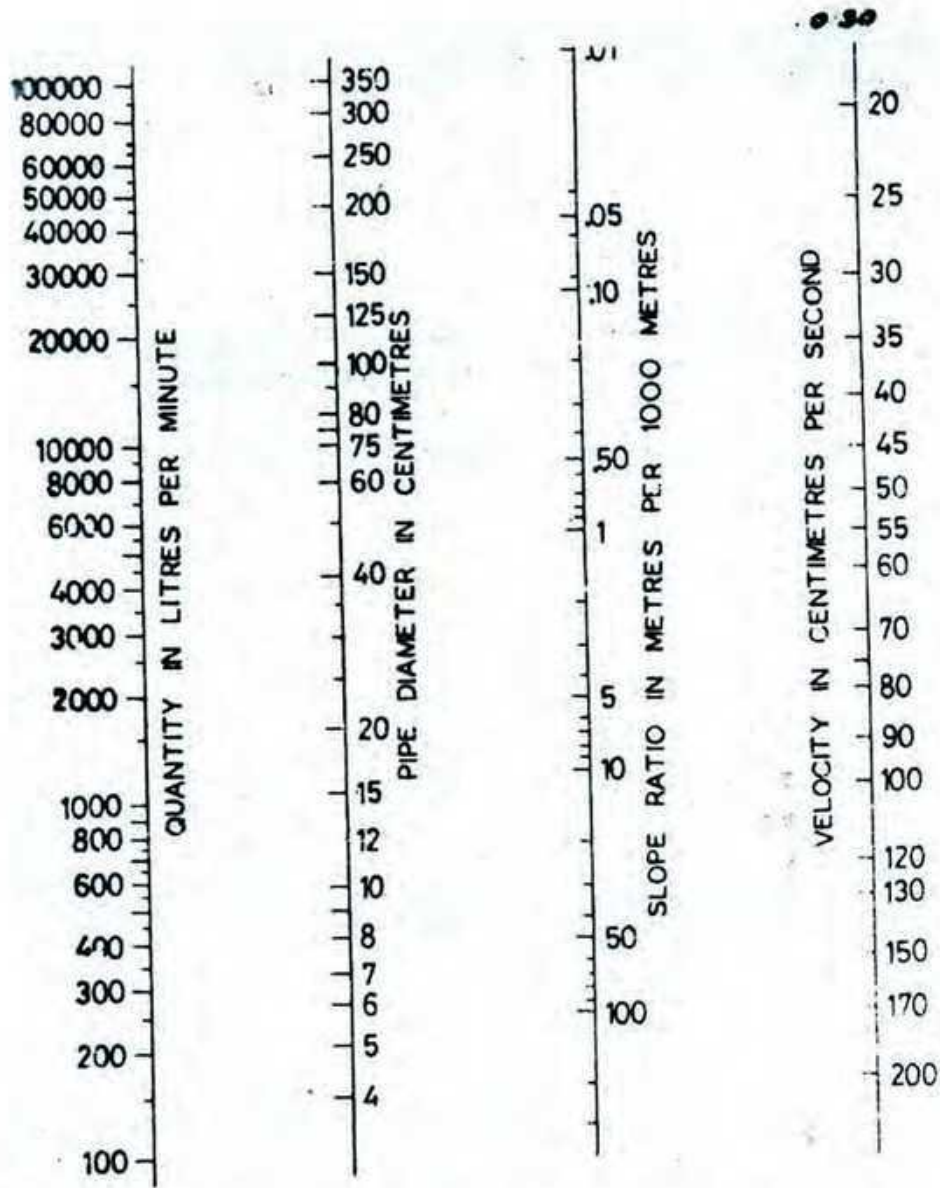

Figure 3: Nomogram based on Manning's formula for circular pipes running full (for $n = 0.013$)

University of Asia Pacific
Department of Civil Engineering
Final Examination Fall 2014
Program: B.Sc. Engineering (Civil)

Course Title: Transportation Engineering I (Transport and Traffic Design)
 Time: 3 Hours

Course Code: CE 351
 Full Marks: 150

Instructions:

1. Use separate scripts for each section.
2. Figures in the right margin indicate marks for each question.
3. Notations and symbols used here carry their usual meanings.
4. Assume reasonable values for missing data.

Section-A

(Answer any three questions)

1. a) What should be the regulations of an effective bus terminal? 7
 b) What are the possible benefits of street lighting? Name the key locations where adequate street lighting is necessary. 8
 c) What is traffic calming device? Explain how traffic calming devices are creating more problems than solving it in Dhaka city. 10

 2. a) What does the parking study include? 5
 b) The following spot speeds (km/hr) were observed for 30 vehicles traversing a segment of a highway. 20
 39, 46, 59, 53, 55, 53, 54, 48, 65, 46, 45, 43, 37, 45, 45, 68, 55, 56, 65, 66, 35, 49, 42, 55, 48, 38, 34, 43, 35, 73.
 Calculate the design speed, average speed, safe speed, median speed and lower limit of speed. (Consider pace as 11-20, 21-30 and so on)

 3. a) Write short note: 12
 (i) Cautionary Traffic Sign
 (ii) Park and ride system
 (iii) Reaction time
 b) Design a two-phase signal at an isolated cross-junction for the following data: 13
 Intergreen time for N-S: 9 sec and E-W: 6 sec.
 Lost time due to starting and end delays : 3 sec (N-S) and 2 sec (E-W)
- | | N | S | E | W |
|---------------------------|------|------|------|------|
| Flow(q), veh/hr | 650 | 710 | 860 | 690 |
| Saturation flow(s) veh/hr | 2250 | 2450 | 2790 | 2650 |
- Also draw the bar diagram.
4. a) What are the causes of delay? Describe them. 8
 b) What are the factors affecting the speed of vehicles? 4
 c) Draw a neat and clean diagram of a simple circular curve and illustrate the following: 13
 i) Mid-ordinate

- ii) Apex distance
- iii) Tangent distance
- iv) Long chord
- v) Length of curve

Section-B

(Answer any three questions)

- | | | |
|----|---|----|
| 5. | a) Define mobility and accessibility in terms of highway classification. | 9 |
| | b) A 4 degree curve (measured at the centerline of the inside lane) is being designed for a highway for a design speed of 80m/hr. What is the closest any roadside object may be placed to the centerline of the inside lane of the roadway? | 16 |
| 6. | a) Write short notes on any three : | 12 |
| | i) Sag vertical curve ii) Color vision | |
| | iii) Brake reaction time iv) Glare recovery | |
| | b) A horizontal curve with a radius of 600 ft is designed for a two-lane highway that has a posted speed limit of 65 mi/h. If the highway is level at this section determine the minimum distance that any roadside object can be placed from the centerline of the inside lane of the curve. Assume PR time 2.5 sec and friction factor 0.4. | 13 |
| 7. | a) Name the main components that influence highway geometric design? | 5 |
| | b) A vehicle initially traveling at 88 km/h skids to a stop on a 3% downgrade, where the pavement surface provides a coefficient of friction equal to 0.3. How far does the vehicle travel before coming to a stop? | 10 |
| | c) Consider a section of rural freeway with a design speed of 80 mi/h. On a section of 3% upgrade terrain, what safe stopping distance must be provided? Consider the AASHTO standard reaction time of 2.5 s. | 10 |
| 8. | a) Describe the various constraints in different transport sector of Bangladesh. | 15 |
| | b) Explain the function of transportation in economical development of Bangladesh. | 10 |

University of Asia Pacific
Department of Civil Engineering
Final Examination Fall 2014
Program: B.Sc. Engineering (Civil)

Course # : CE 363
 Full Marks: 150

Course Title: Engineering Hydrology
 Time: 3 hours

Assume any reasonable value, if not given

Section A

Marks: 75

There are FOUR questions answer any THREE

1(a) What is residence time? Assuming that all the water in the oceans is involved in the hydrological cycle, calculate the average residence time of ocean water. Use the following data. (6)

Volume of ocean water = 1 338 000 000 km³
 Precipitation rate = 458 000 km³ /yr on ocean
 Precipitation rate = 119 000 km³ /yr on land
 Evaporation = 505 000 km³ /yr from ocean
 Evaporation = 72 000 km³ /yr from land

1(b) Calculate in a one step, the precipitable water in a saturated air column of 2000m high above 1 m² of ground surface. The surface pressure is 101.3 kPa, the surface air temperature is 30⁰C and the lapse rate is 6.5⁰C/km. (10)

1(c) Describe following: (3x3=9)

- i) Climate of Bangladesh
- ii) Hydrologic related works
- iii) Raingauge network as per WMO

2(a) Describe the procedure to estimate precipitable water from a static atmospheric air column. (10)

2(b) For a drainage basin of 575 km², isohyets drawn for a storm gave the following data: (10)

Isohyets interval (cm)	31-21	26-21	21-16	16-11	11-6	6-1
Inter isohyetal area (km ²)	80	100	120	150	75	50

Estimate the average depth of precipitation over the catchment.

2(c). A catchment area has five rain gauge stations. In a year the annual rainfall recorded by the gauges are as follows:

Station	A	B	C	D	E
Rainfall (cm)	88	104	138	78	56

For a 10% error in the estimation of the mean rainfall, calculate the minimum number of additional stations required to be established in the catchment. (5)

3(a) Describe the different types of evaporimeters. What are the different analytical methods of evaporation estimation? (6+4=10)

3(b) Why pan coefficient is introduced to calculate evaporation using different evaporation pan? (5)

3(c) Estimate the daily potential evapotranspiration for the following data by Penman's formula: (10)

- i) Slope of the saturation vapour pressure vs. temperature at the mean air temperature = 1.00 mm/°C
- ii) Mean temperature = 19°C
- iii) Relative humidity = 75%
- iv) Wind velocity at 2 m height = 85 km/day
- v) Saturated vapour pressure $e_w = 16.5$ mm of Hg
- vi) Net radiation = 1.99 mm of water per day
- vii) Psychrometric constant = 0.49 mm of Hg/°C

4(a) Explain the following (any Three) (9)

- a) Depth-duration-frequency curve
- b) Infiltration capacity
- c) Rational method to estimate the magnitude of a flood peak
- d) Consistency test for rainfall records

4(b) Rainfall of magnitude 3.8 cm and 2.8 cm occurring on two consecutive 4-h durations on a catchment of area 27 km² produced the following hydrograph of flow at the outlet of the catchment. Estimate the rainfall excess and Φ -index. (7)

Time (h)	-6	0	6	12	18	24	30	36	42
Observed Flow (m ³ /s)	6	5	13	26	21	16	12	9	7
<hr/>									
Time (h)	48	54	60	66					
Observed Flow (m ³ /s)	5	5	4.5	4.5					

4(c) Distinguish between: (3x3=9)

- e) Actual and potential evapotranspiration
- f) Field capacity and permanent wilting point
- g) Recording and non-recording rain gauges

Section B

Marks: 75

There are FOUR questions answer any THREE

5(a) The following are the ordinates of the hydrograph of flow from a catchment area of 780 km² due to a 6-hr rainfall. Derive the ordinates of 6-hr unit hydrograph for the basin. Assume base flow to be uniform at 12m³/s. (15)

Time (hr)	0	6	12	18	24	30	36	42
Discharge(cumec)	12	40	64	215	360	405	350	270
Time (hr)	48	54	60	66	72	78	84	
Discharge(cumec)	205	145	100	70	50	42	11	

5(b) The ordinates of 4-hr UH are given below. Derive the ordinates of an 8-hr UH by the S-curve method. (10)

Time (hr)	0	4	8	12	16	20	24	28
4-hr UH ordinates (cumec)	0	24	82	159	184	151	103	64
Time (hr)	32	36	40	44				
4-hr UH ordinates (cumec)	36	17	6	0				

6(a) How does channel routing differ from reservoir flood routing? What are the factors to be considered in choosing the routing interval? (5)

6(b) The inflow and outflow hydrographs for a reach of a river are given below: (20)

Time (hr)	Inflow (cumec)	Outflow (cumec)
0	20	20
12	191	30
24	249	120
36	164	176
48	110	164
60	82	135
72	62	116
84	48	90
96	32	68
108	28	52

Determine the best values of the Muskingum coefficients k and x for the reach.

7(a) Derive the required expression and different steps for reservoir routing. What data are required for reservoir routing? (10)

7(b) The inflow hydrograph readings for a channel reach are given for which the Muskingum coefficients of $k=30$ hr and $x=0.2$. Route the flood through the reach and determine the attenuation and time lag of outflow. Outflow at the beginning of the flood may be taken as the same as inflow. (15)

Time (hr)	0	12	24	36	48	60	72	84	96
Inflow (cumec)	15	16	31	96	121	102	85	70	57

Time (hr)	108	120	132	144	156	168	180	192	204
Inflow (cumec)	47	39	32	28	24	22	20	19	18

Time (hr)	216	228	240
Inflow (cumec)	17	16	15

8(a) Describe different methods to estimate the magnitude of a flood peak. (7)

8(b) Annual maximum recorded floods in a tributary of the river Brahmaputra for the period 1939 to 1968 is given below which fits well the Gumbel extreme value distribution. Estimate the flood discharge with recurrence interval of 100 years and also find 95% confidence limits for these estimates. (18)

Year	1939	1940	1941	1942	1943	1944	1945	1946	1947	1948
Flood (cumec)	14570	8440	14000	22620	4820	29300	24200	12450	7270	6230

Year	1949	1950	1951	1952	1953	1954	1955	1956	1957	1958
Flood (cumec)	18300	9680	6480	3680	11430	21240	8500	9720	5810	19650

Year	1959	1960	1961	1962	1963	1964	1965	1966	1967	1968
Flood (cumec)	37300	7220	20860	18700	7650	6090	4390	10340	12880	42450

University of Asia Pacific
Department of Civil Engineering
Final Examination Fall 2014
Program: B.Sc. Engineering (Civil)

Course Title: Principles of Management
Time: 2 Hour

Course Code: IMG 301
Full Marks: 50

Answer All the Questions

- | | | |
|------|---|-----|
| 1(a) | What is meant by Power? | 1 |
| (b) | Briefly describe Economic and Cultural Power with examples. | 2+2 |
| (c) | What is meant by Authority? Briefly describe Charismatic Authority with examples. | 3 |
| 2 | Write short notes on: (2x5) | 10 |
| | (a) 80/20 rule | |
| | (b) Strategy Vs Tactics | |
| | (c) Dream Vs Goal | |
| | (d) At least 2 Strength, Weakness, Opportunity and Threat (SWOT) of UAP Civil Engineering Department | |
| | (e) Manager Vs Leader | |
| 3(a) | What is meant by leadership? What are the differences between a leader and a manager? | 1+2 |
| (b) | What are the 3 common traits found among many leaders? | 2 |
| (c) | Briefly describe autocratic leadership style and its limitation. | 3 |
| 4(a) | Why an organization needs control? | 2 |
| (b) | What are the benefits of control? | 2 |
| (c) | What are the demerits of 3 organizational controls? Write at least 2 of each. | 4 |
| 5(a) | Why is Time Management important? | 2 |
| (b) | What are the building blocks of Time Management? Describe Priority Matrix of Time Management with examples. | 1+3 |
| (c) | Mention at least 4 time wasters with examples. | 2 |
| 6(a) | What is Ethics? Why is it important? | 1+2 |
| (b) | Briefly describe ethical decision making rules with examples. | 3 |
| (c) | What are the major causes of corruption? Explain with examples. | 2 |

.....

University of Asia Pacific
Department of Civil Engineering
Final Examination Fall 2014
Program: B.Sc. Engineering (Civil)

Course Title: Project Planning and Management
 Time: 3 hour

Course Code: CE401
 Full Marks: 50

(Answer any 5 out of 6 Questions)

- 1(a) Why is construction safety in Bangladesh not up to the standard? 2
 (b) What is meant by hazard? Give examples in the view of construction management. 2
 (c) Write down the 7 principles to prevent accident in construction site. 3
 (d) Write down the differences between Traditional Quality Control and Modern Quality Control. 3
- 2 Write short notes of the following: 2x5
 (a) ISO 9000
 (b) 80/20 rule
 (c) OSHA
 (d) PPE
 (e) WBS
- 3(a) What is meant by procurement? 2
 (b) Briefly describe Limited Tendering Method (LTM) 3
 (c) What are the criteria to find out the potential sources/bidders in procurement? 2
 (d) What are the points to be remembered for procuring/purchasing? 3
- 4(a) Write down the difference between CPM and PERT 2
 (b) A software firm has estimated the following time for its project. The company has quoted 35 days for the project to be completed. What would be the probability of success that the project will complete on time? 8

Activity	Predecessor	Optimistic Time	Most likely Time	Pessimistic Time
a	-	6	8	10
b	-	7	10	13
c	a	4	4	4
d	b, c	9	12	15
e	a	5	6	7
f	b, c	4	7	10
g	e, f	8	10	12
h	d, e, f	9	12	15

Also determine the total duration of the project and critical path of the project.

... Continued

- 5(a) What do you understand by 'Time Value of Money'? 2
(b) What are major reasons that needed to be considered for 'Replacement'? 1
(d) An asset purchased 2 years ago for \$40,000 is harder to maintain than expected. 7
It can be sold now for \$12,000 or kept for a maximum of 2 more years, in which case its operating cost will be \$20,000 each year, with a salvage value of \$9,000 two years from now. A suitable challenger will have a first cost of \$60,000 with an annual operating cost of \$4,100 per year and a salvage value of \$15,000 after 5 years. Interest rate is 12%. What is the decision?
- 6(a) How will you apply "Project Planning and Management" subject in your professional career? Explain with specific examples. 2
(b) Write down the objectives of material management. 2
(c) A factory has a current market value of \$60,000 and can be kept in service for 4 more years. With an MARR of 12%/year, when should it be abandoned? The following data are projected for future years: 6

	<u>Year 1</u>	<u>Year 2</u>	<u>Year 3</u>	<u>Year 4</u>
Net revenue	\$50,000	\$40,000	\$15,000	\$20,000
Market value	\$35,000	\$20,000	\$15,000	\$10,000
Factory overhauling expenses	-	-	-	\$15,000

Z Score Table- chart value corresponds to area below z score.

z	0.09	0.08	0.07	0.06	0.05	0.04	0.03	0.02	0.01	0.00
-3.4	0.0002	0.0003	0.0003	0.0003	0.0003	0.0003	0.0003	0.0003	0.0003	0.0003
-3.3	0.0003	0.0004	0.0004	0.0004	0.0004	0.0004	0.0004	0.0005	0.0005	0.0005
-3.2	0.0005	0.0005	0.0005	0.0006	0.0006	0.0006	0.0006	0.0006	0.0007	0.0007
-3.1	0.0007	0.0007	0.0008	0.0008	0.0008	0.0008	0.0009	0.0009	0.0009	0.0010
-3.0	0.0010	0.0010	0.0011	0.0011	0.0011	0.0012	0.0012	0.0013	0.0013	0.0013
-2.9	0.0014	0.0014	0.0015	0.0015	0.0016	0.0016	0.0017	0.0018	0.0018	0.0019
-2.8	0.0019	0.0020	0.0021	0.0021	0.0022	0.0023	0.0023	0.0024	0.0025	0.0026
-2.7	0.0026	0.0027	0.0028	0.0029	0.0030	0.0031	0.0032	0.0033	0.0034	0.0035
-2.6	0.0036	0.0037	0.0038	0.0039	0.0040	0.0041	0.0043	0.0044	0.0045	0.0047
-2.5	0.0048	0.0049	0.0051	0.0052	0.0054	0.0055	0.0057	0.0059	0.0060	0.0062
-2.4	0.0064	0.0066	0.0068	0.0069	0.0071	0.0073	0.0075	0.0078	0.0080	0.0082
-2.3	0.0084	0.0087	0.0089	0.0091	0.0094	0.0096	0.0099	0.0102	0.0104	0.0107
-2.2	0.0110	0.0113	0.0116	0.0119	0.0122	0.0125	0.0129	0.0132	0.0136	0.0139
-2.1	0.0143	0.0146	0.0150	0.0154	0.0158	0.0162	0.0166	0.0170	0.0174	0.0179
-2.0	0.0183	0.0188	0.0192	0.0197	0.0202	0.0207	0.0212	0.0217	0.0222	0.0228
-1.9	0.0233	0.0239	0.0244	0.0250	0.0256	0.0262	0.0268	0.0274	0.0281	0.0287
-1.8	0.0294	0.0301	0.0307	0.0314	0.0322	0.0329	0.0336	0.0344	0.0351	0.0359
-1.7	0.0367	0.0375	0.0384	0.0392	0.0401	0.0409	0.0418	0.0427	0.0436	0.0446
-1.6	0.0455	0.0465	0.0475	0.0485	0.0495	0.0505	0.0516	0.0526	0.0537	0.0548
-1.5	0.0559	0.0571	0.0582	0.0594	0.0606	0.0618	0.0630	0.0643	0.0655	0.0668
-1.4	0.0681	0.0694	0.0708	0.0721	0.0735	0.0749	0.0764	0.0778	0.0793	0.0808
-1.3	0.0823	0.0838	0.0853	0.0869	0.0885	0.0901	0.0918	0.0934	0.0951	0.0968
-1.2	0.0985	0.1003	0.1020	0.1038	0.1056	0.1075	0.1093	0.1112	0.1131	0.1151
-1.1	0.1170	0.1190	0.1210	0.1230	0.1251	0.1271	0.1292	0.1314	0.1335	0.1357
-1.0	0.1379	0.1401	0.1423	0.1446	0.1469	0.1492	0.1515	0.1539	0.1562	0.1587
-0.9	0.1611	0.1635	0.1660	0.1685	0.1711	0.1736	0.1762	0.1788	0.1814	0.1841
-0.8	0.1867	0.1894	0.1922	0.1949	0.1977	0.2005	0.2033	0.2061	0.2090	0.2119
-0.7	0.2148	0.2177	0.2206	0.2236	0.2266	0.2296	0.2327	0.2358	0.2389	0.2420
-0.6	0.2451	0.2483	0.2514	0.2546	0.2578	0.2611	0.2643	0.2676	0.2709	0.2743
-0.5	0.2776	0.2810	0.2843	0.2877	0.2912	0.2946	0.2981	0.3015	0.3050	0.3085
-0.4	0.3121	0.3156	0.3192	0.3228	0.3264	0.3300	0.3336	0.3372	0.3409	0.3446
-0.3	0.3483	0.3520	0.3557	0.3594	0.3632	0.3669	0.3707	0.3745	0.3783	0.3821
-0.2	0.3859	0.3897	0.3936	0.3974	0.4013	0.4052	0.4090	0.4129	0.4168	0.4207
-0.1	0.4247	0.4286	0.4325	0.4364	0.4404	0.4443	0.4483	0.4522	0.4562	0.4602
-0.0	0.4641	0.4681	0.4721	0.4761	0.4801	0.4840	0.4880	0.4920	0.4960	0.5000

Interest Rate		12.00%							12.00%	
n	F/P	P/F	A/F	A/P	F/A	P/A	A/G	P/G	n	
1	1.120	0.8929	1.0000	1.1200	1.000	0.893	0.000	0.000	1	
2	1.254	0.7972	0.4717	0.5917	2.120	1.690	0.472	0.797	2	
3	1.405	0.7118	0.2963	0.4163	3.374	2.402	0.925	2.221	3	
4	1.574	0.6355	0.2092	0.3292	4.779	3.037	1.359	4.127	4	
5	1.762	0.5674	0.1574	0.2774	6.353	3.605	1.775	6.397	5	
6	1.974	0.5066	0.1232	0.2432	8.115	4.111	2.172	8.930	6	
7	2.211	0.4523	0.0991	0.2191	10.089	4.564	2.551	11.644	7	
8	2.476	0.4039	0.0813	0.2013	12.300	4.968	2.913	14.471	8	
9	2.773	0.3606	0.0677	0.1877	14.776	5.328	3.257	17.356	9	
10	3.106	0.3220	0.0570	0.1770	17.549	5.650	3.585	20.254	10	
11	3.479	0.2875	0.0484	0.1684	20.655	5.938	3.895	23.129	11	
12	3.896	0.2567	0.0414	0.1614	24.133	6.194	4.190	25.952	12	
13	4.363	0.2292	0.0357	0.1557	28.029	6.424	4.468	28.702	13	
14	4.887	0.2046	0.0309	0.1509	32.393	6.628	4.732	31.362	14	
15	5.474	0.1827	0.0268	0.1468	37.280	6.811	4.980	33.920	15	
16	6.130	0.1631	0.0234	0.1434	42.753	6.974	5.215	36.367	16	
17	6.866	0.1456	0.0205	0.1405	48.884	7.120	5.435	38.697	17	
18	7.690	0.1300	0.0179	0.1379	55.750	7.250	5.643	40.908	18	
19	8.613	0.1161	0.0158	0.1358	63.440	7.366	5.838	42.998	19	
20	9.646	0.1037	0.0139	0.1339	72.052	7.469	6.020	44.968	20	
21	10.804	0.0926	0.0122	0.1322	81.699	7.562	6.191	46.819	21	
22	12.100	0.0826	0.0108	0.1308	92.503	7.645	6.351	48.554	22	
23	13.552	0.0738	0.0096	0.1296	104.603	7.718	6.501	50.178	23	
24	15.179	0.0659	0.0085	0.1285	118.155	7.784	6.641	51.693	24	
25	17.000	0.0588	0.0075	0.1275	133.334	7.843	6.771	53.105	25	
26	19.040	0.0525	0.0067	0.1267	150.334	7.896	6.892	54.418	26	
27	21.325	0.0469	0.0059	0.1259	169.374	7.943	7.005	55.637	27	
28	23.884	0.0419	0.0052	0.1252	190.699	7.984	7.110	56.767	28	
29	26.750	0.0374	0.0047	0.1247	214.583	8.022	7.207	57.814	29	
30	29.960	0.0334	0.0041	0.1241	241.333	8.055	7.297	58.782	30	
31	33.555	0.0298	0.0037	0.1237	271.293	8.085	7.381	59.676	31	
32	37.582	0.0266	0.0033	0.1233	304.848	8.112	7.459	60.501	32	
33	42.092	0.0238	0.0029	0.1229	342.429	8.135	7.530	61.261	33	
34	47.143	0.0212	0.0026	0.1226	384.521	8.157	7.596	61.961	34	
35	52.800	0.0189	0.0023	0.1223	431.663	8.176	7.658	62.605	35	
36	59.136	0.0169	0.0021	0.1221	484.463	8.192	7.714	63.197	36	
40	93.051	0.0107	0.0013	0.1213	767.091	8.244	7.899	65.116	40	
48	230.391	0.0043	0.0005	0.1205	1911.59	8.297	8.124	67.41	48	
50	289.002	0.0035	0.0004	0.1204	2400.02	8.304	8.160	67.76	50	
52	362.524	0.0028	0.0003	0.1203	3012.70	8.310	8.189	68.06	52	
60	897.597	0.0011	0.0001	0.1201	7471.64	8.324	8.266	68.81	60	
70	2787.80	0.0004	0.0000	0.1200	23223.3	8.330	8.308	69.21	70	
72	3497.02	0.0003	0.0000	0.1200	29133.5	8.331	8.313	69.25	72	
80	8658.48	0.0001	0.0000	0.1200	72145.7	8.332	8.324	69.36	80	
84	13624.3	0.0001	0.0000	0.1200	113527.	8.333	8.327	69.39	84	
90	26891.9	0.0000	0.0000	0.1200	224091.	8.333	8.330	69.41	90	
96	53079.9	0.0000	0.0000	0.1200	442324.	8.333	8.332	69.43	96	
100	83522.3	0.0000	0.0000	0.1200	696011.	8.333	8.332	69.43	100	
inf.	inf.	0.0000	0.0000	0.1200	inf.	8.3333	8.333	69.44	inf.	

University of Asia Pacific
Department of Civil Engineering
Final Examination Fall 2014 (Set A)
Program: B.Sc. Engineering (Civil)

Course Title: Structural Engineering III
 Time: 3hrs

Course Code: CE 411
 Full Marks: 10x10=100

[Answer any 10 (ten) of the following 14 (fourteen) questions]

1. For the truss shown in *Fig. 1*, ignore the zero-force members and apply the boundary conditions to determine the value of unknown joint displacements [Given: $S_x = 1000 \text{ k/ft}$].

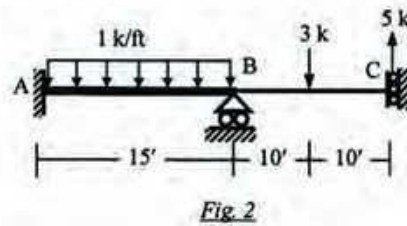
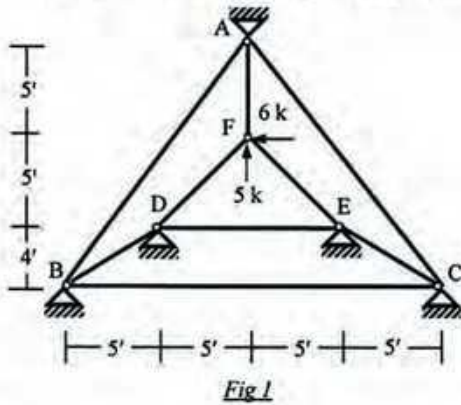

2. Use Stiffness Method (neglecting axial deformations) to calculate the joint deflection and rotation of the beam shown in *Fig. 2* [Given: $EI_{AB} = 40 \times 10^3 \text{ k-ft}^2$, $EI_{CD} = 20 \times 10^3 \text{ k-ft}^2$].

3. For the frame shown below in *Fig. 3*, assemble the global stiffness matrix considering boundary conditions and neglecting axial deformation. Also write down the global load vector [Given: $EI = 40 \times 10^3 \text{ ksf}$, $A = 1 \text{ ft}^2$].

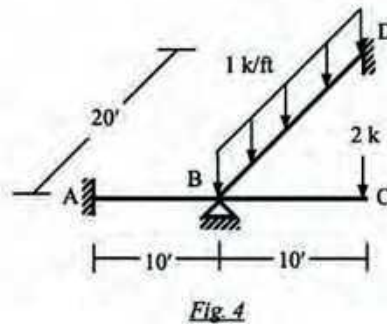
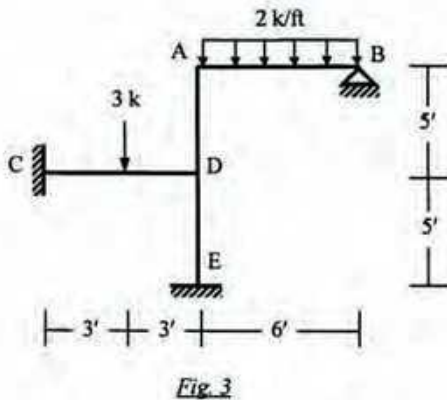

4. For the grid loaded as shown in *Fig. 4*, use the stiffness method to calculate the rotations at joint B [Given: $EI = 40 \times 10^3 \text{ k-ft}^2$, $GJ = 30 \times 10^3 \text{ k-ft}^2$].

5. In the three-dimensional truss shown in *Fig. 5*, ignore zero-force members and formulate the stiffness matrix, load vector and write down the boundary conditions [Given: $EA/L = 500 \text{ k/ft}$].

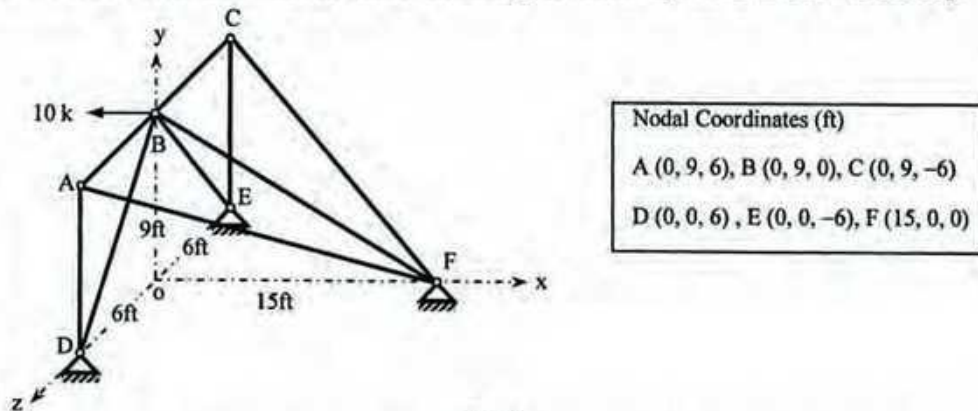

Fig. 5

6. Use Stiffness Method to calculate the unknown joint rotations and displacement for the beam ABC loaded as shown in *Fig. 6*, considering flexural deformations only with geometric nonlinearity [Given: $EI = 50 \times 10^3 \text{ k-ft}^2$].

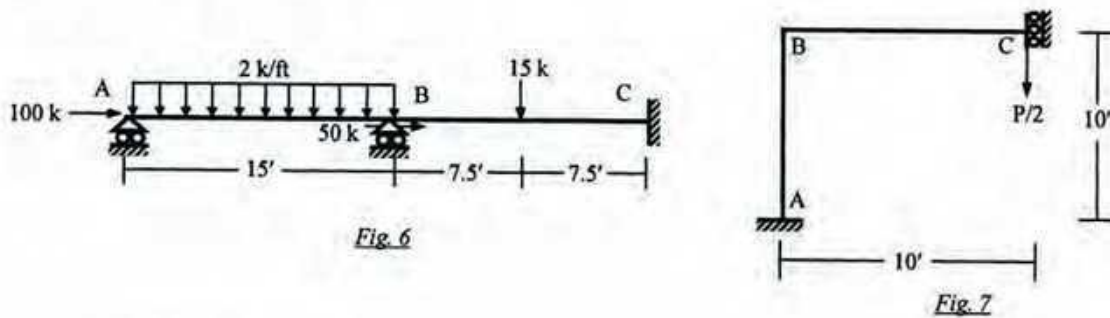

Fig. 6

Fig. 7

7. Use the Stiffness Method (considering geometric nonlinearity) to calculate the approximate first critical buckling load for the frame loaded as shown in *Fig. 7* [Given: $EI = 50 \times 10^3 \text{ k-ft}^2$].

8. Use the Energy Method to calculate the plastic moment M_p needed to prevent the development of plastic hinge mechanism in the beam ABCD loaded as shown in *Fig. 8* [Given: $M_{p(ABCD)} = M_p$].

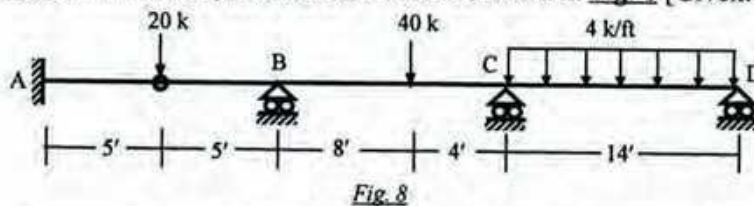

Fig. 8

9. Use bending moment diagram to calculate the force P needed to develop plastic hinge mechanism in the beam ABCD loaded as shown in *Fig. 9* [Given: $\sigma_{yp} = 40 \text{ ksi}$].

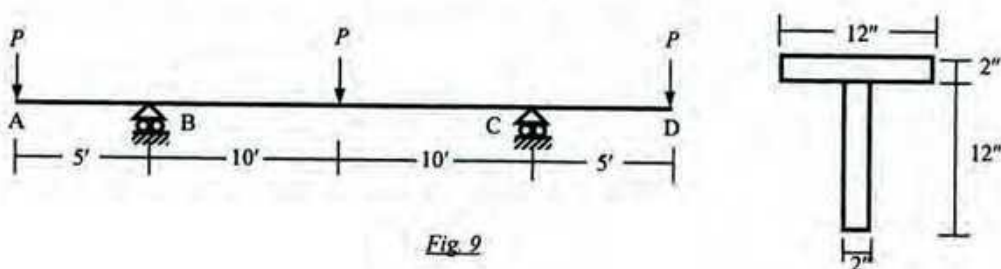

Fig. 9

10. For the plane truss shown in *Fig. 1*, applying boundary conditions calculate its natural frequencies using consistent mass matrices [Given, $E = 30000 \text{ ksi}$, $A = 2 \text{ in}^2$, $m = 1.5 \times 10^{-6} \text{ k-sec}^2/\text{in}^2$].

11. For the beam shown in *Fig. 2*, calculate the approximate first natural frequency in transverse direction using consistent mass matrices [Given, $EI = 54 \times 10^3 \text{ k-ft}^2$, $m = 0.0045 \text{ k-sec}^2/\text{ft}^2$].

12. For the beam loaded as shown in *Fig. 10*, use the Stiffness Method to calculate the rotation at joint B and vertical displacement of joint C, if B is supported by a circular foundation of radius 2-ft on sub-soil (half-space) [Given: Unit weight of soil = 0.12 k/ft^2 , shear wave velocity (v_s) = 500 ft/sec , Poisson's ratio = 0.25 , $EI = 40 \times 10^3 \text{ k-ft}^2$].

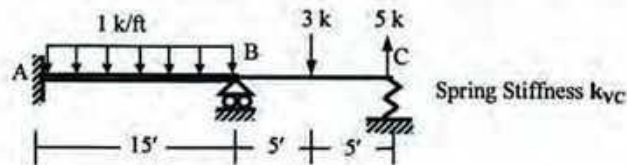

Fig. 10

13. Briefly explain why

- i. a truss member hinged at both ends is a zero-force member
- ii. axial deformations are sometimes neglected for the structural analysis of frames but not trusses
- iii. stiffness matrix of a 3D truss member is (6×6) while that of a 3D frame member is (12×12)
- iv. the effect of foundation flexibility can be beneficial or harmful to the structure
- v. a structure becomes unstable at buckling load (explain in terms of stiffness matrix)

14. Determine the size of the stiffness matrices (with and without considering boundary conditions) of the trusses and frames shown in *Fig. 11*. Also determine the size of the stiffness matrices of the frames if axial deformations are neglected.

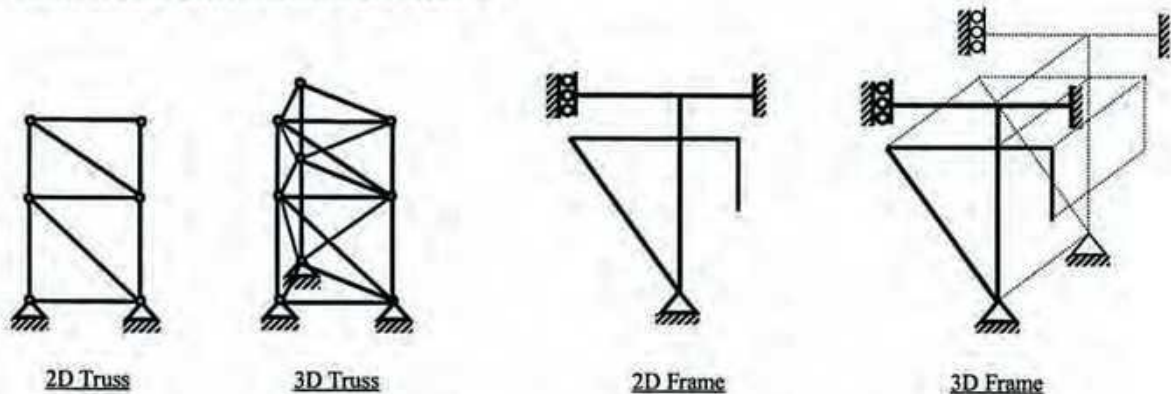

Fig. 11

University of Asia Pacific
Department of Civil Engineering
Final Examination Fall 2014 (Set B)
Program: B.Sc. Engineering (Civil)

Course Title: Structural Engineering III
 Time: 3hrs

Course Code: CE 411
 Full Marks: 10x10=100

[Answer any 10 (ten) of the following 14 (fourteen) questions]

1. For the truss shown in *Fig. 1*, ignore the zero-force members and apply the boundary conditions to determine the value of unknown joint displacements [Given: $S_x = 1000$ k/ft].

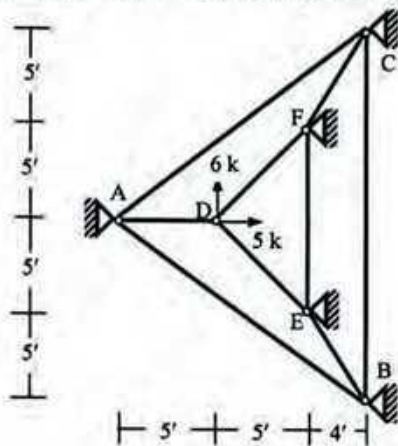

Fig 1

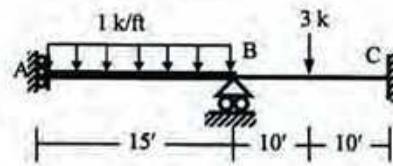

Fig. 2

2. Use Stiffness Method (neglecting axial deformations) to calculate the joint deflection and rotation of the beam shown in *Fig. 2* [Given: $EI_{AB} = 40 \times 10^3$ k-ft², $EI_{CD} = 20 \times 10^3$ k-ft²].

3. For the frame shown below in *Fig. 3*, assemble the global stiffness matrix considering boundary conditions and neglecting axial deformation. Also write down the global load vector [Given: $EI = 40 \times 10^3$ ksf, $A = 1$ ft²].

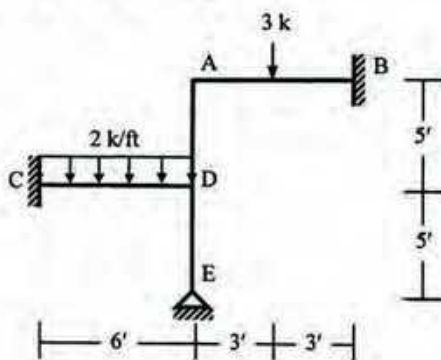

Fig. 3

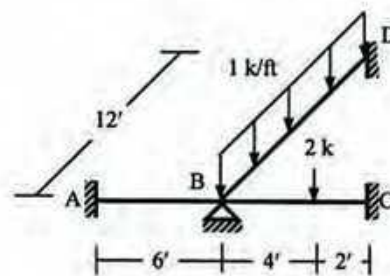

Fig. 4

4. For the grid loaded as shown in *Fig. 4*, use the stiffness method to calculate the rotations at joint B [Given: $EI = 40 \times 10^3$ k-ft², $GJ = 30 \times 10^3$ k-ft²].

5. In the three-dimensional truss shown in *Fig. 5*, ignore zero-force members and formulate the stiffness matrix, load vector and write down the boundary conditions [Given: $EA/L = 500$ k/ft].

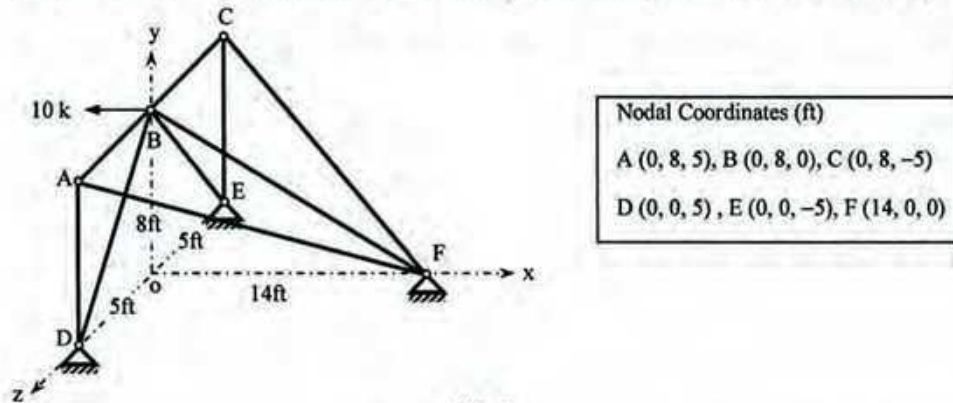

Fig. 5

6. Use Stiffness Method to calculate the unknown joint rotations and displacement for the beam ABC loaded as shown in *Fig. 6*, considering flexural deformations only with geometric nonlinearity [Given: $EI = 50 \times 10^3$ k-ft²].

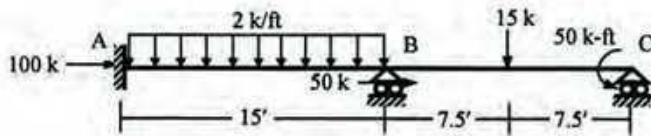

Fig. 6

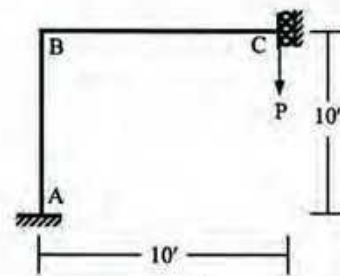

Fig. 7

7. Use the Stiffness Method (considering geometric nonlinearity) to calculate the approximate first critical buckling load for the frame loaded as shown in *Fig. 7* [Given: $EI = 50 \times 10^3$ k-ft²].

8. Use the Energy Method to calculate the plastic moment M_p needed to prevent the development of plastic hinge mechanism in the beam ABCD loaded as shown in *Fig. 8* [Given: $M_{p(ABCD)} = M_p$].

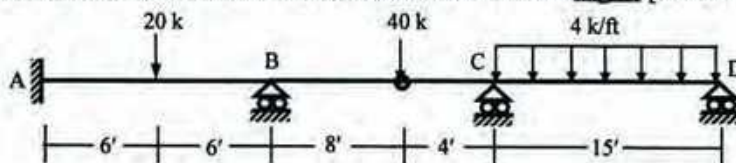

Fig. 8

9. Use bending moment diagram to calculate the force P needed to develop plastic hinge mechanism in the beam ABCD loaded as shown in *Fig. 9* [Given: $\sigma_{yp} = 40$ ksi].

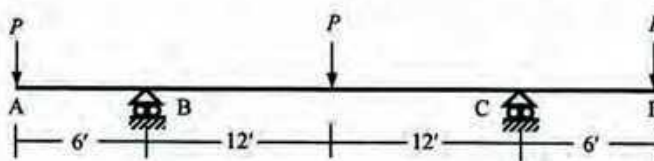
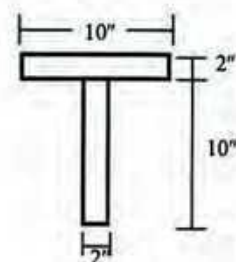

Fig. 9



10. For the plane truss shown in *Fig. 1*, applying boundary conditions calculate its natural frequencies using consistent mass matrices [Given: $E = 30000$ ksi, $A = 2$ in², $m = 1.5 \times 10^{-6}$ k-sec²/in²].

11. For the beam shown in *Fig. 2*, calculate the approximate first natural frequency in transverse direction using consistent mass matrices [Given: $EI = 54 \times 10^3$ k-ft², $m = 0.0045$ k-sec²/ft²].

12. For the beam loaded as shown in *Fig. 10*, use the Stiffness Method to calculate the rotation at joint B and vertical displacement of joint C, if B is supported by a circular foundation of radius 2-ft on sub-soil (half-space) [Given: Unit weight of soil = 0.12 k/ft², shear wave velocity (v_s) = 500 ft/sec, Poisson's ratio = 0.25 , $EI = 40 \times 10^3$ k-ft²].

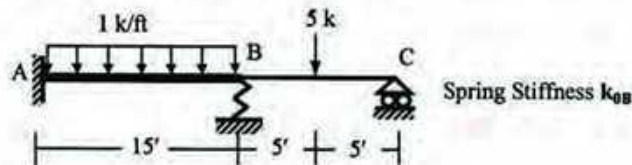

Fig. 10

13. Briefly explain why

- i. a truss member hinged at both ends is a zero-force member
- ii. axial deformations are sometimes neglected for the structural analysis of frames but not trusses
- iii. stiffness matrix of a 3D truss member is (6×6) while that of a 3D frame member is (12×12)
- iv. the effect of foundation flexibility can be beneficial or harmful to the structure
- v. a structure becomes unstable at buckling load (explain in terms of stiffness matrix)

14. Determine the size of the stiffness matrices (with and without considering boundary conditions) of the trusses and frames shown in *Fig. 11*. Also determine the size of the stiffness matrices of the frames if axial deformations are neglected.

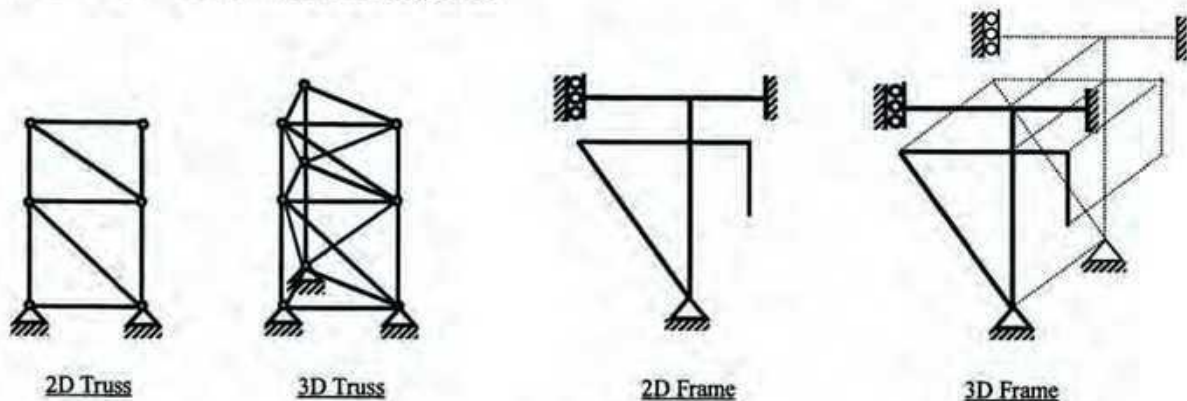

Fig. 11

University of Asia Pacific
Department of Civil Engineering
Final Examination Fall – 2014
Program: B. Sc. Engineering (Civil)

Course Title: Geotechnical Engineering II
 Time: 3 hours

Course Code: CE 441
 Full Marks: 120 (20 X 6 = 120)

Answer any 6 (six) of the following 8 (eight) questions

1. (a) What is subsurface exploration in terms of geotechnical engineering? Mention four purposes of geotechnical subsurface exploration. 6
- (b) What preliminary information should be available to a good geotechnical engineer to execute a subsurface exploration program for a multi-span bridge project. 2
- (c) Write down any four general guidelines used for the selection of depth of boreholes for different civil engineering projects. 4
- (d) Write short notes (any two): 4 x 2 = 8
- (i) Site reconnaissance
- (ii) Any one in-situ test, except SPT
- (iii) Observation of ground water table
2. (a) A geotechnical site investigation was conducted at a site near Munshiganj. The field blow counts as obtained at the site for a particular boring are tabulated below. Estimate the Field SPT values. Apply necessary corrections and calculate corrected SPT values as required (Use Appendix, as necessary). Ground water table was found to be located at a depth of 5 feet below the existing ground surface. Also determine undrained cohesion and angle of internal friction for clay and sand, as applicable, at corresponding depths. Assume CF_{60} to be equal to 1.0. 7

Soil Type as Obtained	γ (pcf)	γ_{sat} (pcf)	Depth below EGL (feet)	Blow Counts		
				1 st six inches	2 nd six inches	3 rd six inches
CLAY up to a depth of 7.5 feet	115	125	5	1	3	4
SAND below 7.5 to a depth of 12.5 feet	118	120	10	3	5	5
CLAY below 12.5 to a depth of 15 feet	110	112	15	3	4	5

- (b) Column load at a location for a site is estimated to be 288 Kips. The site is explored to a depth of 40 feet below EGL. Assuming an anticipated bearing capacity of 2.0 ksf for a square footing check whether the exploration is sufficient or not. Assume the foundation level to be about 5 feet below EGL. Justify your answer in terms of significant induced stress. 6
- (c) A geotechnical site investigation was conducted at a site in Bangladesh. From the sub-surface soil information as provided below and in the next page, estimate n_3 at corresponding depth. Use Appendix A in conjunction with the following information: 7
- (i) Borehole dia = 4 inches (ii) No liner was used during drilling
- n_1 = SPT blow counts for first 6-inch penetration
 n_2 = SPT blow counts for second 6-inch penetration
 n_3 = SPT blow counts for third 6-inch penetration

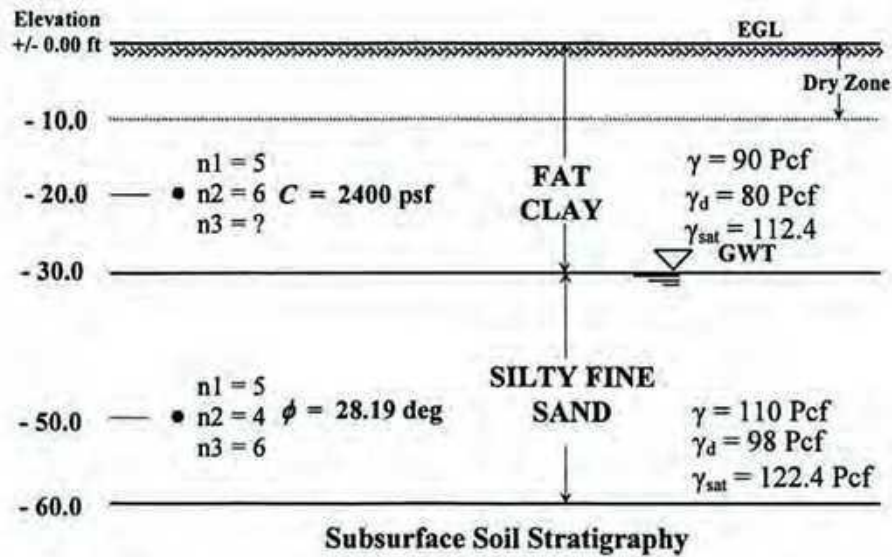

3. (a) Write the names of any five (5) in-situ testing performed in the field under the field investigation phase of a sub-surface exploration program. Write a very short note on the one frequently used in Bangladesh? 4
- (b) The outside and inside diameters of a split-spoon sampler are 2 inches and 1.4 inches, respectively and those of a Shelby tube sampler are 3 inches and 2.85 inches, respectively. Estimate the degree of disturbances for two soil samples; one obtained using the split-spoon sampler and the other using the Shelby tube. Also determine whether the samples are disturbed or undisturbed. 4
- (c) Depict and write short notes on general and local shear failure patterns for shallow foundation. 5
- (d) From a preliminary field investigation, the subsurface condition obtained is shown in the figure below. SPT-N values were obtained at each 5-foot depth intervals. Using Terzaghi's bearing capacity equation (as appropriate), determine the allowable column load (P_{all}) for the individual column rectangular footing founded as shown below. Use $F.S = 3$. 7

NOTE: No laboratory tests were conducted to obtain the shear strength of the clay formation. So, use empirical correlation to estimate the average shear strength below the foundation level.

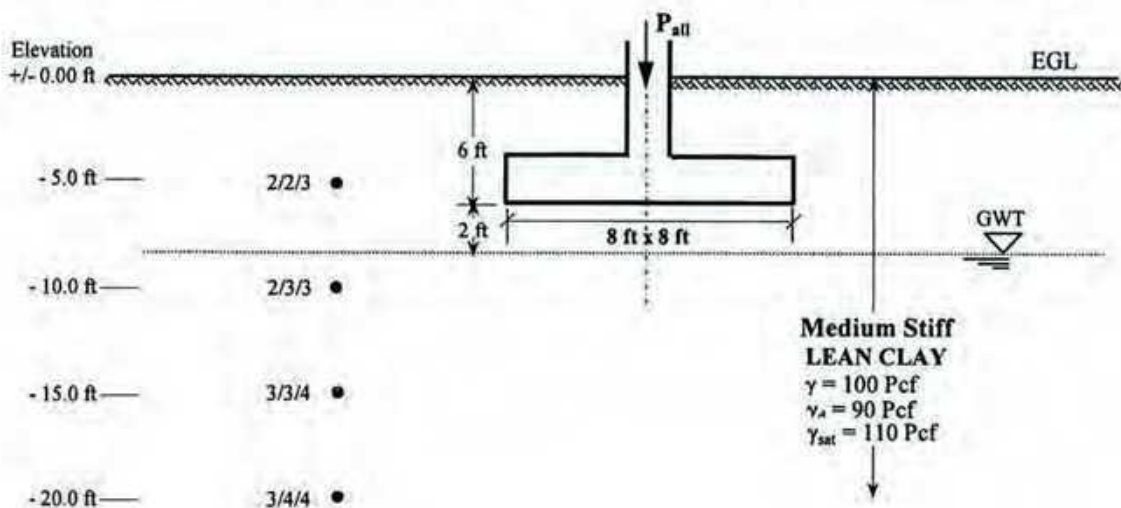

4. (a) A shallow circular foundation is to be constructed in sandy clay soil as shown in the figure below. Design the size of the circular footing (Use GBCE) for the allowable column load of 100 Kips. Use FS = 2.5 and assume $Df/B \leq 1$.

11

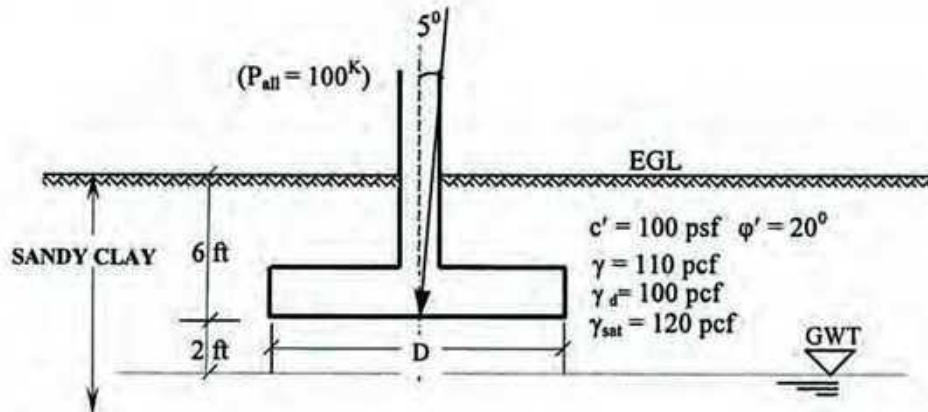

- (b) Allowable load of an eccentrically loaded rectangular footing (as shown below) using Meyerhof's effective area method is calculated to be 190 k. Determine the length of the footing. Use FS = 2.5.

9

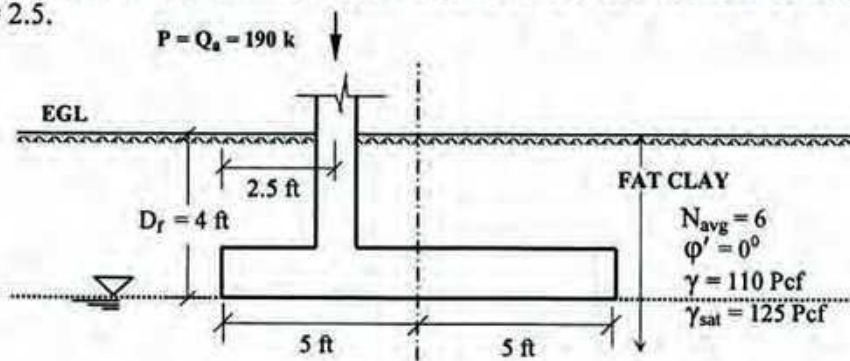

5. (a) For the following loading, geometric and boundary conditions a trapezoidal combined footing is designed. According to analysis, the dimension of the longer parallel of the trapezoid was estimated to be of 13.2 feet. Estimate the other dimension of the longer parallel and allowable bearing capacity for the system. Use bigger column dimensions as 18-inch by 18-inch and shorter dimensions as 12-inch by 12-inch.

8

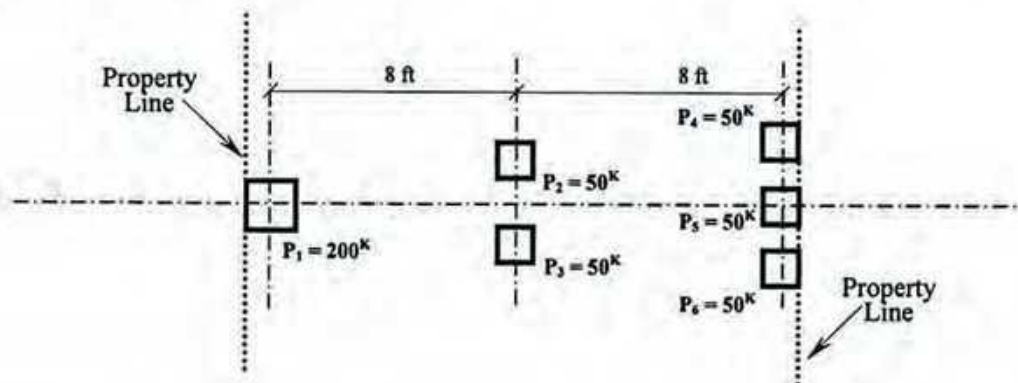

- (b) The plan of a mat foundation is shown in the figure in the next page. Calculate the soil pressures at points a, c and at the geometric centroid of the foundation (all the columns are 15 by 15 inches in size).

12

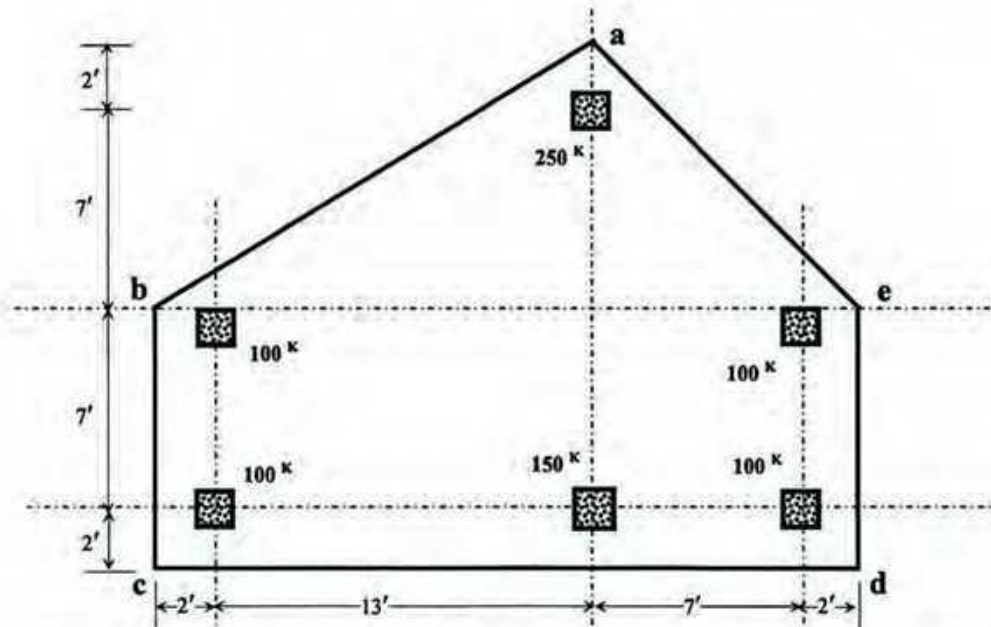

6. (a) For a fully compensated condition (floating foundation), if the depth of the mat foundation is selected to be 25 ft. below EGL, determine the number of stories that could be built. Consider uniform per floor load of 250 psf.

6

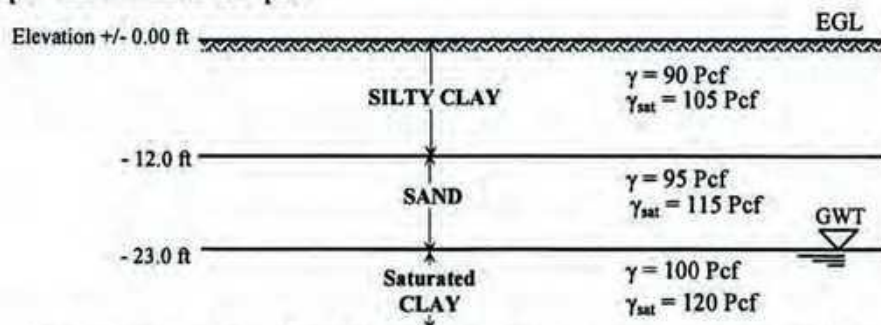

- (b) A footing designed as per allowable bearing capacity based on shearing failure is shown in the following figure. Estimate settlements for both sand and clay layers. Use $q_a = p = 2.4 \text{ ksf}$.

14

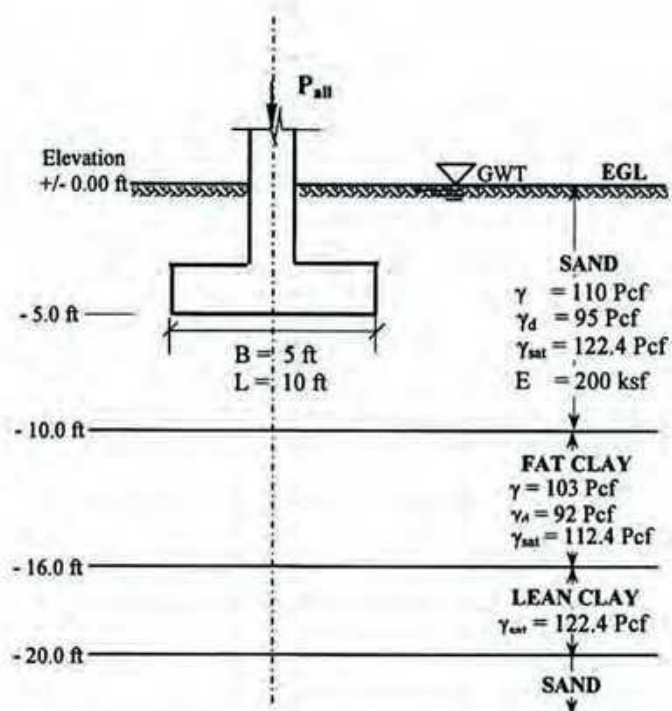
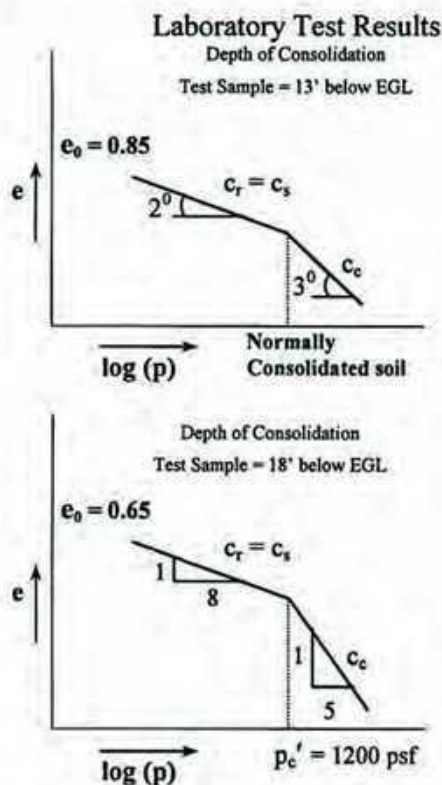

7. (a) For the soil stratigraphy as shown below, a concrete bored pile having diameter of 18 inches was installed. Calculate the capacity of the single pile.

9

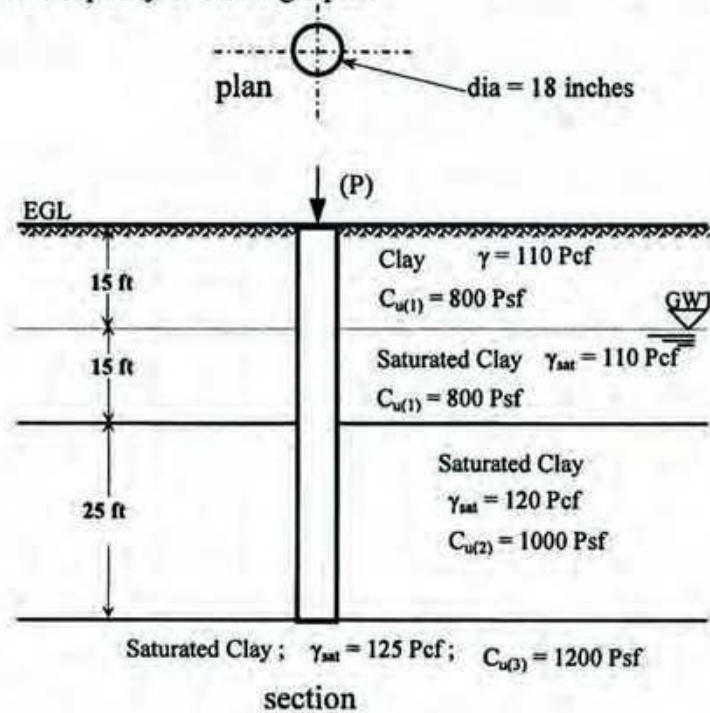

- (b) The plan and X-section of a 15-meter long single pre-cast concrete pile (square) driven in different sand deposits are shown below. Estimate the allowable capacity of the single pile.

11

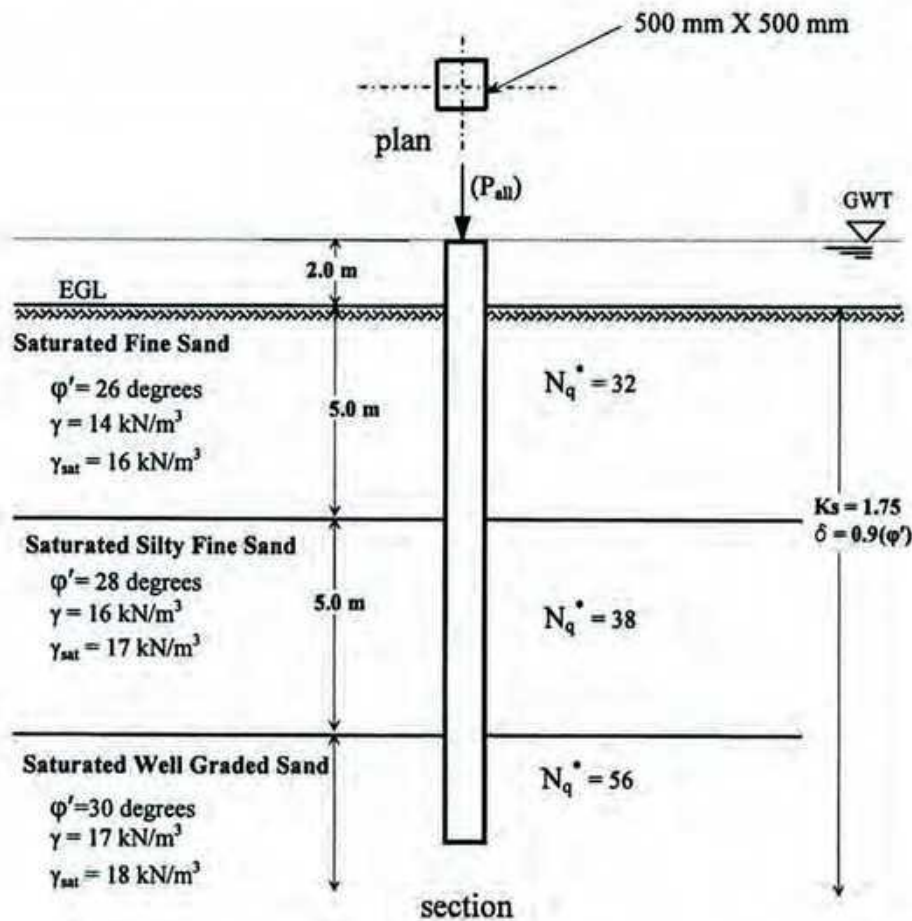

8. (a) Draw arrangement of group piles for the following sets of piles.

4

- (i) 7 piles (ii) Triple row for a wall

(b) Mention a few civil engineering features where slope stability problems are frequently encountered.

2

(c) Determine the factor of safety (slope stability) against the failure arc through the slope as shown below.

14

LAYER I: Sandy Clay; Unit Weight = 17 kN/m^3
Average SPT Blow Count, $N_{60} = 7$

LAYER II: Clay; Unit Weight = 18.0 kN/m^3
Average SPT Blow Count, $N_{60} = 10$

LAYER III: Clay; Unit Weight = 19 kN/m^3
Average SPT Blow Count, $N_{60} = 14$

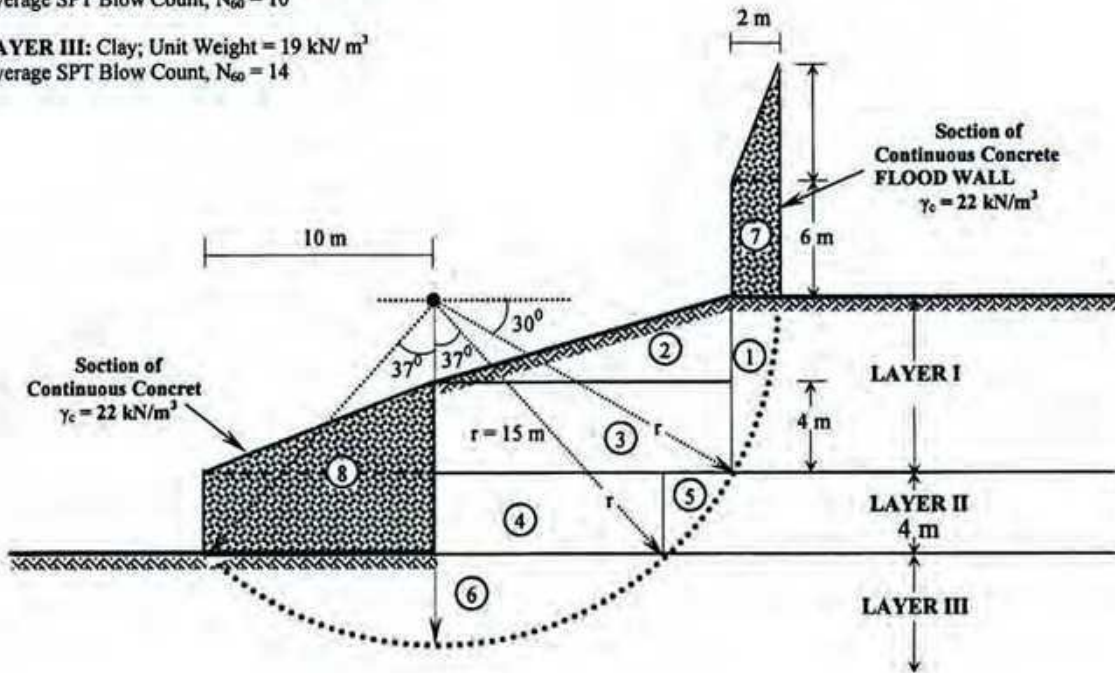

University of Asia Pacific
Department of Civil Engineering
Final Examination Fall 2014
Program: B.Sc. Engineering (Civil)

Course Title: Transportation Engineering II

Course Number: CE 451

Time: 3 hours

Full Marks: 150

Section: A

Answer any 3 (three) questions from the following 4 (four) questions (3x25=75)

1. (a) What is interlocking? What are the essential principles of interlocking? (4)
(b) Sketch various types of wear on rails with proper labeling. (6)
(c) Name the main constituents of a set of points or switches? (5)
(d) Explain: Minimum depth of Ballast Cushion (4)
(e) Write down the main considerations/requirements for design of ideal rail section components. (6)
2. (a) Define: Calendar System of Maintenance (3)
(b) Demonstrate fish plate and combination fish plate with proper diagram. (7)
(c) Briefly describe the main constituents of details of crossing. (6)
(d) What is tractive power? Describe briefly the resistance due to friction. (4)
(e) Find out the length of transition curve for a B. G. curve of four degrees, having a cant of 15 cm. The maximum permissible speed on the curve is 120 kmph. And the maximum permissible value of super-elevation is 165, 102 and 76 mm for B.G., M.G., and N.G. respectively. (5)
3. (a) What are the comparisons between block and non-block stations? (3)
(b) Write down the typical layout of signals at junctions with diagram. (4)
(c) What is grade compensation on curves? Explain. (5)
(d) What is shift? What are the reasons of curve resistance? (5)
(e) A transition curve is to be used to join the ends of three degree circular curve with the straight. The length of the transition curve is 180 m. Work out the shift and offsets at every 60 m in interval and also sketch a free-hand diagram. (8)
4. ~~(a)~~ Write down the comparisons between compressed air brakes and vacuum brakes. (3)
(b) What are the methods to improve embankment stability? (5)
~~(c)~~ What are the requirements of a good spike? (4)
~~(d)~~ Write down the classification of stations as per functional consideration. (5)
(e) What should be the equilibrium cant on a M. G. curve of 5° for an average speed of 60 kmph? Also find out the maximum permissible speed after allowing the maximum cant deficiency 5.10 cm. (8)

Section: B

Answer any 3 (three) questions from the following 4 (four) questions (3x25=75)

1. (a) What is resilient modulus? (2)
(b) Briefly demonstrate the Asphalt Institute Method for thickness design of a variety of asphalt pavements. (13)
(c) Calculate Equivalent 18000-lb Standard Axle Load Applications during the first year of service of a pavement, the pavement is expected to accommodate the following number of vehicles in the classes shown below:

Vehicle type	Number of vehicles	Truck factor
Two-axle, four-tire	94000	0.03
Two-axle, six-tire	23600	0.19
Three-axle or more	7300	0.56
Three-axle	4500	0.61
Four axle or more	7350	0.62
Five axle	50200	1.09
Six-axle or more	8900	1.23

Also determine Design ESAL for 25-Year Design Period if the traffic using the pavement grows at an annual rate of 5%. (10)

2. (a) Write down the comparisons between joint filler and joint sealer. (5)
(b) Briefly demonstrate various types of joints in case of pavement. (10)
(c) The amount of lime required for coarse grained soil in lime stabilization is lower than that of plastic soils. Why? Explain. (3)
(d) Write down the comparisons among prime coat, tack coat and seal coat. (4)
(e) What is surface dressing? Write down the functions of surface dressing. (3)
3. (a) Write down the comparisons among three types of concrete pavements. (5)
(b) Briefly describe the design criteria and design factors of Portland Cement Association Method in case of thickness design of a concrete pavement. (12)
(c) Describe various types of load on pavement with relevant examples. (3)
(d) Name separate steps sequentially for construction of a typical concrete pavement. (5)
4. (a) Define: Stability, Durability (3)
(b) Briefly demonstrate the general steps used in determining the job-mix formula. (12)
(c) The percentage by weight for coarse aggregate, fine aggregate and mineral filler is 50, 35 and 10 respectively. The bulk specific gravity of coarse and fine aggregates is 2.61 and 2.69 respectively, while the apparent specific gravity of mineral filler is 3.10. What is the bulk specific gravity of aggregate? If the maximum specific gravity of the paving mix is 2.40 and specific gravity of asphalt cement is 1.05, calculate the effective specific gravity of aggregate, asphalt absorption of aggregate and effective asphalt content of the paving mix. (10)

Equations:

$$1. S = \frac{L^2}{24R}$$

$$2. D = \frac{1746.50}{R}$$

$$3. D = \frac{5730}{R_1}$$

$$4. y = \frac{x^3}{6RL}$$

$$5. L = 7.20 * e$$

$$6. L = 0.073 C_d V_{max}$$

$$7. L = 0.073 e V_{max}$$

$$8. V = 4.4 \sqrt{(R - 70)}$$

$$9. V = 3.6 \sqrt{(R - 6)}$$

$$10. S.E. = 1.315 \frac{V^2}{R}$$

$$11. S.E. = 0.60 \frac{V^2}{R}$$

$$12. S.E. = 0.80 \frac{V^2}{R}$$

$$13. T = \left[\frac{(1+r)^n - 1}{r} \right] T_1$$

$$14. G_{se} = \frac{P_{mm} - P_b}{\frac{P_{mm}}{G_{mm}} - \frac{P_b}{G_b}}$$

$$15. G_{sb} = \frac{\frac{P_1 + P_2 + P_3}{g_1 + g_2 + g_3}}{\frac{P_1}{g_1} + \frac{P_2}{g_2} + \frac{P_3}{g_3}}$$

$$16. P_{ba} = 100 \frac{G_{se} - G_{sb}}{G_{sb} G_{se}} G_b$$

$$17. P_a = 100 \frac{G_{mm} - G_{mb}}{G_{mm}}$$

$$18. P_{be} = P_B - \frac{P_{ba}}{100} P_S$$

**All the parameters have their usual meanings.

University of Asia Pacific
Department of Civil Engineering
Final Examination Fall 2014
Program: B.Sc. Engineering (Civil)

Course title: Irrigation and Flood Control
 Time: 3 hours

Course code: CE 461
 Full marks: 100

There are TWO sections in the question paper namely "SECTION A" and "SECTION B". You have to answer from the both sections according to the instruction mentioned on each section.

SECTION A
MARKS: 75

There are SIX questions. Answer question no. 01 (COMPULSORY) and any THREE from the rest. (Assume any missing data.)

1. a) Define irrigation. Write the benefits of irrigation and the harmful effects of excess irrigation. 2+4
 b) What are the different methods of irrigation water distribution? Describe basin flooding method along with its advantages and disadvantages. 2+4
 c) What are cross-drainage works? Explain the necessity of cross-drainage works. 4
 d) Define spillway. Explain the procedures for determining the required discharge capacity and number of spillways. 1+4

2. a) Explain river training works. What are the purposes of marginal bunds? 2+2
 b) Determine the time required to irrigate a strip of land of 0.04 hectares in area from a tube-well with a discharge of 0.02 m³/sec. The infiltration capacity of the soil may be taken as 5 cm/h and the average depth of flow on the field as 10 cm. Also determine the maximum area that can be irrigated from this tube well. 7
 c) Wheat has to be grown at a certain place, the useful climatological conditions of which are tabulated below. Determine the evapo-transpiration and consumptive irrigation requirement of wheat crop. Also determine the field irrigation requirement if the water application efficiency is 80%. Use Blaney-Criddle equation and a crop factor is 0.8. 7

Month	Monthly temperature (°C) averaged over the last 5 years	Monthly percent of day time hour of the year computed from the Sun-shine	Useful rainfall in cm averaged over the last 5 years
November	18.0	7.20	1.7
December	15.0	7.15	1.42

January	13.5	7.30	3.01
February	14.5	7.10	2.75

3. a) Derive the relationship between Duty and Delta for a given base period. 3
 b) Explain the following with neat sketch: i) Aqueduct ii) Super passage iii) Level crossing. 6
 c) A stream of 130 liters per second was diverted from a canal and 100 liters per second were delivered to the field. An area of 1.6 hectares was irrigated in 8 hours. The effective depth of root zone was 1.7 m. The runoff loss in the field was 420 m³. The depth of water penetration varied linearly from 1.7 m at the head end of the field to 1.1 m at the tail end. Available moisture holding capacity of the soil is 20 cm per meter depth of soil. Irrigation was started at a moisture extraction level of 50% of the available moisture. 9
 Find out the following:
 • water conveyance efficiency
 • water application efficiency
 • water storage efficiency
4. a) Draw the schematic diagram of soil-water-plant relationship. 3
 b) Graphically demonstrate the following (in one figure): 5
 • Capillary water
 • Hygroscopic water
 • Optimum moisture content
 • Readily available moisture
 • Permanent wilting point
 • Field capacity
 c) After how many days will you supply water to soil in order to ensure sufficient irrigation of the given crop, if, 10
 • Field capacity of the soil = 30%
 • Permanent wilting point = 15%
 • Dry density of soil = 1.3 gm/cc
 • Effective depth of root zone = 77 cm
 • Daily consumptive use of water for the given crop = 12 mm
 • Readily available moisture is 75% of the available moisture.
5. a) Explain free board and berms. What are the purposes of free board? 2
 b) Draw the typical layout of diversion head works. What are the objectives of diversion head works? 4
 c) Describe how centrifugal pump works with neat sketch. 3
 d) Calculate the balancing depth for a channel section having a bed width equal to 18 m and side slopes of 1:1 in cutting and 2:1 in filling. The bank embankments are kept 3.0 m higher than the ground level (berm level) and crest width of banks is kept as 2.0 m. 9

6. a) Distinguish between weir and barrage with neat sketch. 2.5
 b) What is groyne? Explain different types of groyne with neat sketch. 3.5
 c) Explain the following: i) Coefficient of rugosity ii) Critical velocity ratio iii) Hydraulic mean depth iv) Non-alluvial soil 6
 d) Design a lined canal having the following data: 6
 Full supply discharge = $40 \text{ m}^3/\text{sec}$
 Side slope = 1:1
 Bed slope = 1 in 5000
 Rugosity coefficient = 0.0225
 Assume other reasonable data for the design.

SECTION B
MARKS: 25

There are FOUR questions. Answer question no. 07 (COMPULSORY) and any TWO from the rest. (Assume any missing data.)

7. What are the types of measures of flood management? Distinguish between them. 2+2+5
 Write down the methods of flood management under each type.
8. a) Explain the following (any three) 8
 i. Integrated Water Resources Management
 ii. Embankment
 iii. Flood plain
 iv. Polder
9. a) Write down the names of the major studies and plans that shaped the water resources development of Bangladesh. 4
 b) Write down the FAP guiding principles of flood management. 4
10. a) What are the advantages and disadvantages of flood control projects? 5
 b) Define integrated flood management. 3

University of Asia Pacific
Department of Civil Engineering
Final Examination Fall 2014
Program: B.Sc. Engineering (Civil)

Course Title: Professional Practices and Communication
Time: 2 Hour

Course Code: CE 403
Full Marks: 50

Answer all questions.

- 1 Read the following passage and give answer with explanation from Engineering ethical point of view: 10
- Engineer A, a renowned structural engineer, is hired for a nominal sum by a large city newspaper to visit the site of a state bridge construction project, which has had a troubled history of construction delays, cost increases, and litigation primarily as a result of several well-publicized, on-site accidents. Recently the state highway department has announced the date for the opening of the bridge. State engineers have been proceeding with repairs based upon a specific schedule. Engineer A visits the bridge and performs a one-day visual observation. Her report identifies, in very general terms, potential problems and proposes additional testing and other possible engineering solutions.
- Thereafter, in a series of feature articles based upon information collected from Engineer A's report, the newspaper alleges that the bridge has major safety problems that jeopardize its successful completion date. Allegations of misconduct and incompetence are made against the project engineers and the contractors as well as the state highway department. During an investigation by the state, Engineer A states that her report was intended merely to identify what she viewed were potential problems with the safety of the bridge and was not intended to be conclusive as to the safety of the bridge.
- Was it ethical for Engineer A to agree to perform an investigation for the newspaper in the manner stated?
- 2(a) What is meant by Dispute? Describe the most common causes of dispute in construction contract. 1+2
- (b) Mention the names of the methods (at least 4) of dispute resolution. 2
- (c) When Negotiation is a better option for resolving dispute? Briefly describe the method of Negotiation. 2+3
- 3(a) What is arbitration? Briefly describe the process of arbitration 1+2
- (b) What are the merits and demerits of arbitration? 2
- (c) What is Litigation? When can this method be applied? 1+2
- (d) Write down the disadvantages of litigation. 2
- 4(a) What are the common components of a thesis? 2
- (b) What are the criteria of a good abstract? What should be avoided in abstract writing? 2+2
- (c) Describe the points to be considered for a good Title of a proposal/thesis 4
- 5(a) Describe the 4 characteristics of a good procurement process. 2
- (b) Describe the Technical and Financial Evaluation of Bidder Selection Criteria. 2.5
- (c) Mention the 5 basic processes of Bid Management 2
- (d) What information is typically collected for pre-qualification? 2
- (e) What is meant by Winners curse and Lowball bids? Please Explain. 1.5
-

University of Asia Pacific
Department of Civil Engineering
Final Examination Fall 2014
Program: B.Sc. Engineering (Civil)

Course No: CE 415

Course Title: Structural Engineering V

Time: 2.0 hours

Full Marks: 100

There are five questions. Answer any four questions. The figures in the right margin indicate the marks of the questions. Assume value for any missing data.

1. (a) Make a preliminary design for section of a prestressed-concrete beam to resist a total moment of 420 KN-m including girder self weight moment 115 kN-m. Assume a trial depth of the section is $42\sqrt{M_T}$ in mm (where M_T is in kN-m) . The effective prestress for steel is 750 MPa, and allowable stress for concrete under working load is 12 MPa. (8)
- (b) A symmetric I-shaped beam is prestressed with $A_{ps}=2189 \text{ mm}^2$ as prestressing steel with an effective stress f_{se} of 1100 MPa. The c.g.s. of the strands is 115 mm above from the bottom of the beam. Determine the ultimate moment of the section in **Figure: 1** using strain compatibility method. (17)
 (Given: $f'_c = 48 \text{ MPa}$ and $\beta_1=0.7$, Start trial of 'c' value with 250 mm)

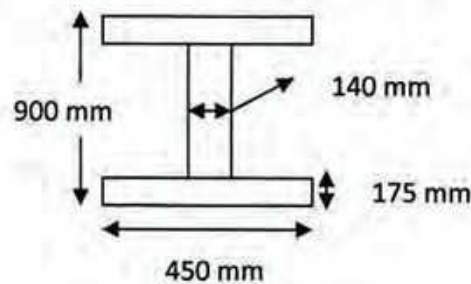

Figure: 1

2. (a) Show the stress distributions in a prestressed concrete beam section for different locations of compressive force (C) according to elastic theory. (10)
- (b) Fourteen steel wires of 9 mm diameter with anchorages are used for prestressing of a 15m pretensioned beam. The beam has symmetrical I-section shown in **Figure: 1**. Determine the position for the c.g.s. line. [Given: $f'_o=860\text{MPa}$, $f_{se}= 750 \text{ MPa}$, $f'_b= 3 \text{ MPa}$, $f'_t= 3 \text{ MPa}$, $M_G= 75 \text{ kN-m}$, $M_T=270 \text{ kN-m}$ at midspan]. (15)
3. A section of simply supported composite beam is shown in **Figure: 2**. The precast stem is prestressed with an effective force of 400 kips assuming a total loss as 15%. Compute the stresses in the section at different stage of loading and also draw the stress distribution at these stages if the bending moment at the section are as follows: (25)
 - Due to precast stem = 250 k-ft
 - Due to top slab = 80 k-ft
 - Due to live load = 400 k-ft

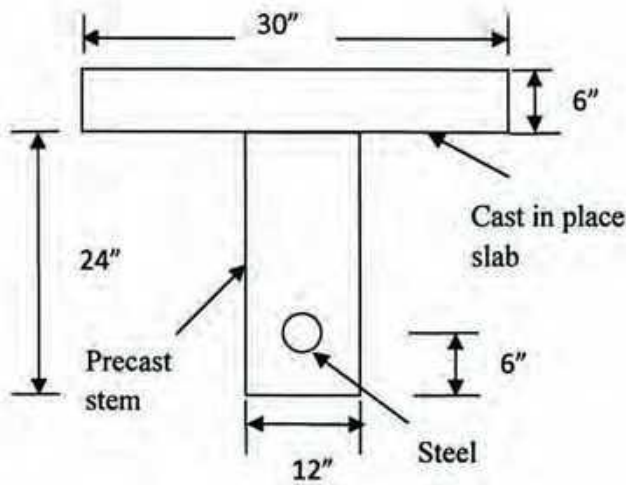

Figure: 2

4. (a) Check the shear strength for the beam shown in Figure: 3 at section 1-1 which is 3 m from support. Given that this section is adequate for $w_u = 70$ kN/m on the basis of its flexural strength. (Given: $f_c = 40$ MPa, $f_{se} = 1100$ MPa, $A_{ps} = 1760$ mm²) (15)

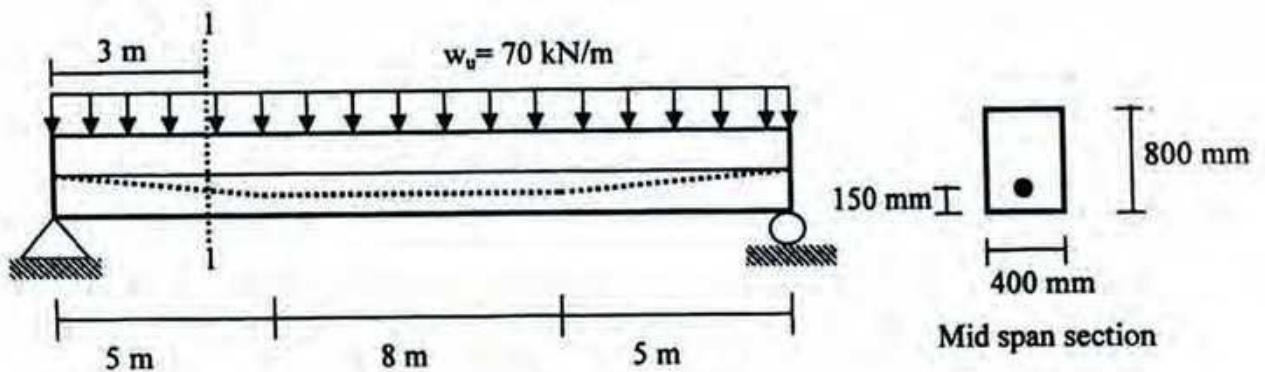

Figure: 3

- (b) What are the advantages and disadvantages of partial prestressing? Define “transfer length” and write down the parameters which affect the length of transfer for prestressing steel of pretensioned member. (4+2+4)
5. (a) Calculate the mid-span deflection of a 16 m span I-beam as shown in Figure: 4 (20)
- (i) Immediately at transfer of prestress and (ii) after 12 years.
- The beam carries a superimposed dead load of 4 kN/m and service load of 6 kN/m in addition to its self weight. It has to carry a concentrated live load of 75 kN at midspan. Assume that, superimposed dead loads are applied soon after prestress transfer.
- Given: $A_{ps} = 1760$ mm², $A_c = 240000$ mm², $I = 2.408 \times 10^{10}$ mm⁴, $f_t = 1300$ MPa, $f_{se} = 1120$ MPa, $E_c = 27400$ MPa, $C_c = 2.3$, $\gamma_{con} = 24$ kN/m³

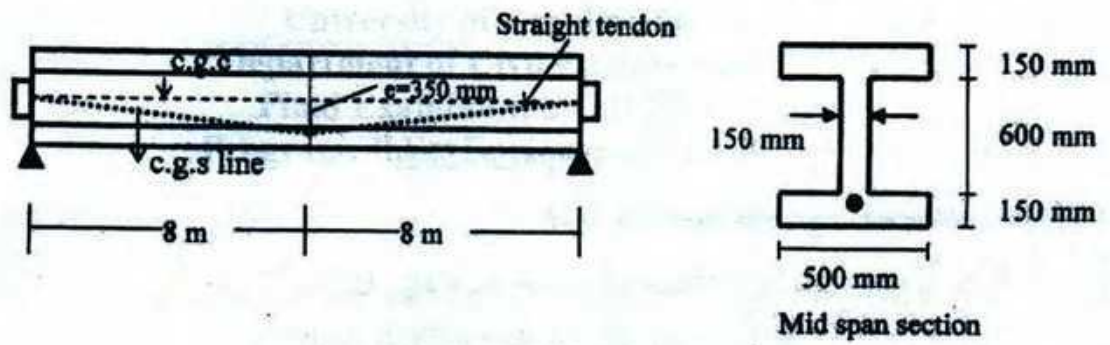

Figure: 4

(b) Draw the load deflection curve of a prestressed beam.

(5)

Formulae Sheet

* $F = M_T / (0.65h)$, if M_G is greater than 20% of M_T

* $F = M_L / (0.5h)$, if M_G is less than 20% of M_T , where $M_L = M_T - M_G$

* $A_c = A_{ps} f_{se} / 0.5 f_c$ * $\epsilon_{pu} = \epsilon_{pu} + \epsilon_{ce} + \epsilon_{ct} = (f_{se} / E_s) + (f_c / E_c) + [\epsilon_{pu} \{ (d-c) / c \}]$

* $K = r^2 / c$ * $M_t = f'_b A_c k_t$

* $F = -(F/A) \pm (Fey/I) \pm (My/I)$ * $V_{ci} = 0.05 \sqrt{f'_c} b_w d + V_d + V_i M_{cr} / M_{max}$

* $M_{cr} = (I/y_b) (0.5 \sqrt{f'_c} + f_{pe} - f_d)$ * $f_{pe} = (F/A) + (Fey_b / I)$ * $a_1 = M_T / F$ * $a_2 = M_G / F_o$

* $e_t = f'_b I / F c_b$ * $e_b = f'_t I / F_o c_t$

* Δ_p in a simply supported beam = $(5wl^4 / 384EI)$

* Δ_w in a simply supported beam = $(5wl^4 / 384EI)$

* Δ_m in a simply supported beam = $(Ml^2 / 8EI)$

* Δ_{pl} in a simply supported beam = $(Pl^3 / 48EI)$

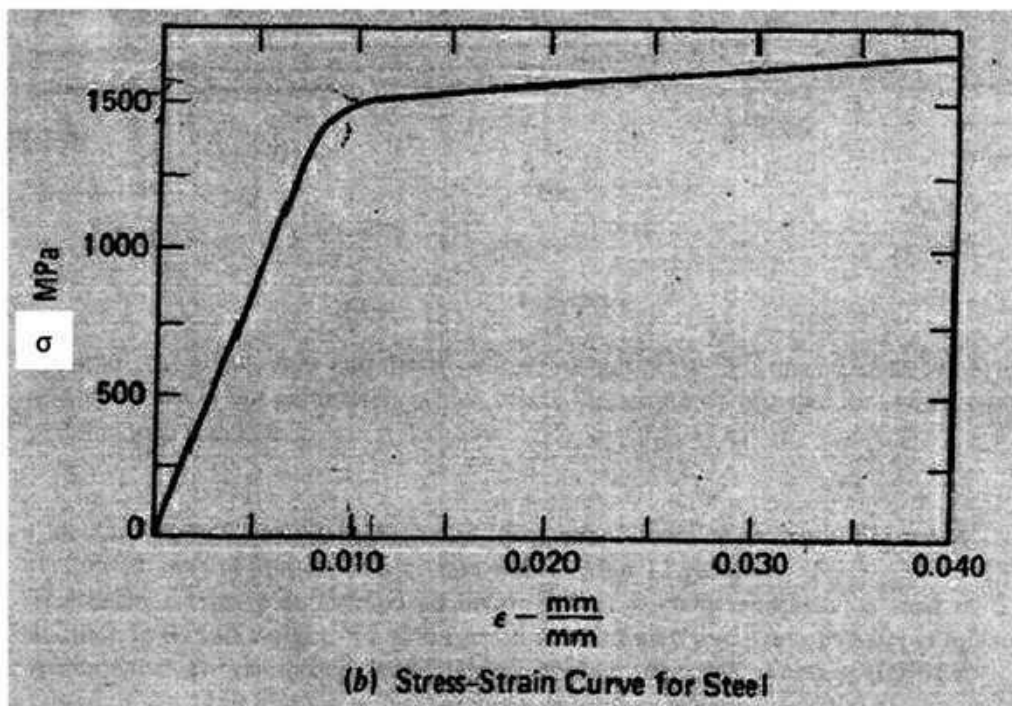

University of Asia Pacific
Department of Civil Engineering
Final Examination Fall 2014
Program: B.Sc. Engineering (Civil)

Course Title: Structural Analysis and Design VI
 Time: 2 Hours

Course Code: CE417
 Full Marks: 120

Section- A : Answer any 3 (Three) of the following 4 (Four) questions

1. (a) Write short notes on the following: (04)

- i. Stiffened and Unstiffened elements
- ii. Elastic and plastic section modulus

(b) The beam shown in the following figure has lateral support at locations a, b, c and d. Compute C_b for segment b-c. Use the unfactored service load as shown. (16)

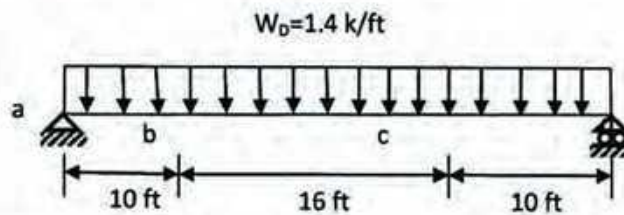

2. (a) Write short notes on compact and non-compact section. (04)

(b) Compute the following for the cross section shown in figure below. Assume A 992, 50 Grade steel. (16)

- i. Yield moment
- ii. Plastic moment
- iii. Shape factor

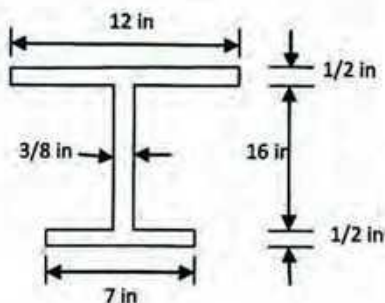

3. (a) Discuss residual stress including its effects. (05)
- (b) Define effective length factor. Calculate effective length factors for column BC, EF, CD and FG shown in the following figure. Moment of inertia of columns and beams are shown in figure. (Use Annexure-1). (15)

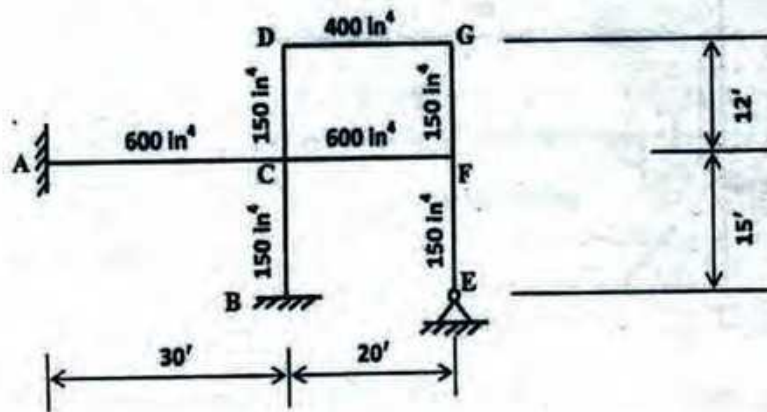

4. (a) State the typical differences between steel and concrete structures. (04)
- (b) The beam shown in the following figure is a W 10×77 and is laterally unsupported except at ends. If $F_y=50$ ksi, Calculate the maximum permissible value of P. Neglect self-weight of the beam and follow ASD principle. For this beam $C_b=1.32$. (Use Annexure-2). (16)

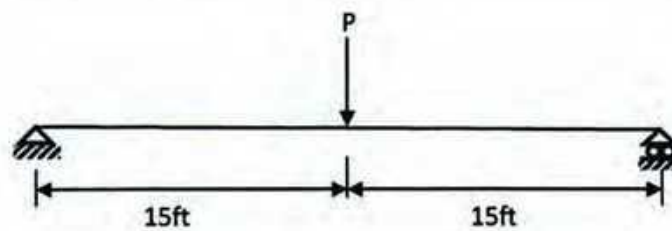

Section- B: Answer any 3 (Three) of the following 4 (Four) questions

5. (a) What is meant by C_b and L_c ? (04)
- (b) Calculate the allowable strength (in ASD) of a W 14 × 90 column section with a strong axis unbraced length of 30 ft and weak axis unbraced length of 15 ft. Assume ends of unbraced lengths as pinned. The materials is ASTM A 992 ($F_y=50$ ksi and $F_u=65$ ksi). Annexure 3 is provided to facilitate the design. (16)
6. (a) Draw a column strength curve and indicate regions of short, intermediate and long column. How does failure of short column differ from that of long column? (05)
- (b) Use ASD method to select lightest section of A 36 steel for a 20 feet long column to carry an axial load of 170 kip. Assume Fixed-Pinned ends of 20 ft long column in both axes. Probable column sizes with sectional properties are given below. (15)

Size	A_g (in ²)	r_x (in)	r_y (in)
W 10×39	11.5	4.27	1.98
W 10×45	13.3	4.30	2.01
W 12×40	11.8	5.13	1.93

7. (a) What do you understand by shear lag? Describe with figures. (04)
- (b) Investigate the adequacy of the connection if the total load applied is 75 k as shown in the figure. It includes 4 -7/8 dia A 325 bolts in standard hole bearing type connection with threads excluded from shear plate. Assume A 572 Grade 50 steel. (16)

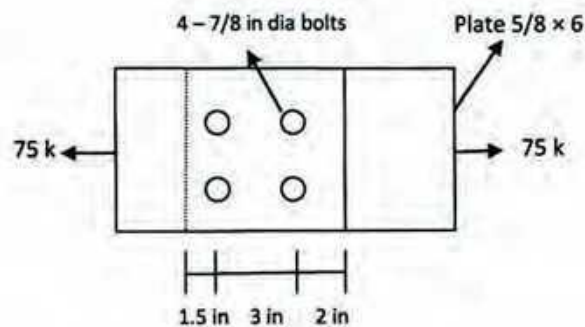

8. (a) What is Lateral Torsional Buckling? How is it prevented? (05)
- (b) The following figure shows a flat bar used as a tension member and connected to a gusset plate. The welds are $3/16$ in fillet weld made of E 70 XX electrode. The connected parts are A 992 steel. Determine the strength of the connection. (15)

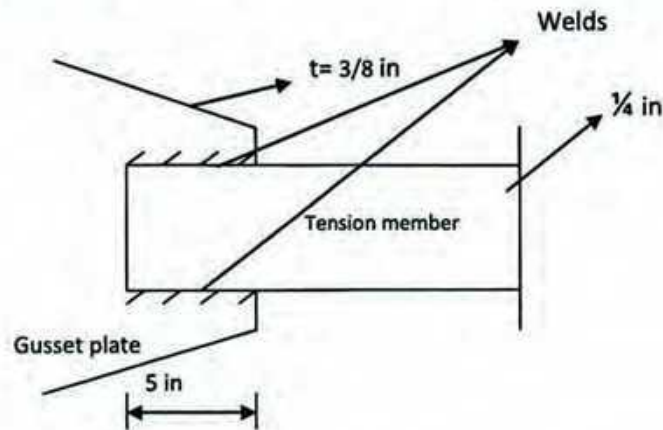

Annexure-1

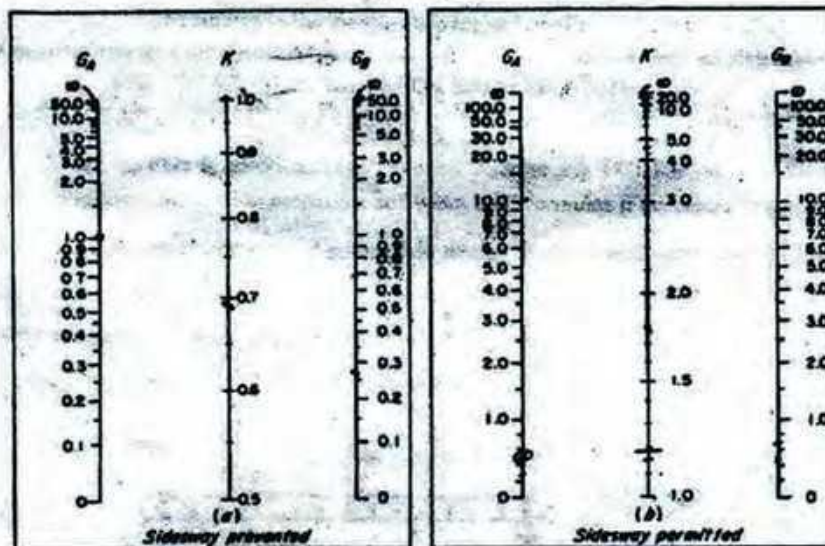

Nomograph for effective length of columns.

Annexure-2

W Shapes Dimensions										W Shapes Properties																		
Shape	Area, A	Depth, d	Web		Flange		Dimensions				Composite Section Criteria		Axis X-X					Axis Y-Y					Torsional Properties					
			Thickness, t _w	t _w /d	Width, b _f	Thickness, t _f	t _f /b _f	r _{xx}	r _{yy}	r _{xy}	r _{xx}	r _{yy}	r _{xy}	I _x	S _x	I _y	S _y	J	C _w									
			in.	in.	in.	in.	in.	in.	in.	in.	in.	in.	in.	in. ⁴	in. ³	in. ⁴	in. ³	in. ⁶	in. ⁴									
W14x12	36.8	14.7	14%	0.540	1/2	14.7	14%	1.03	1	1.83	2 1/8	1 1/2	10	6 1/2	7.18	17.7	1630	209	8.29	234	548	74.8	3.76	113	4.29	18.8	12.3	26900
x120	36.3	14.5	14%	0.530	1/2	14.7	14%	0.840	1 1/4	1.54	2 1/4	1 1/2	10	6 1/2	7.80	19.3	1390	190	8.24	212	485	67.3	3.74	102	4.20	13.5	9.37	22700
x108	32.0	14.3	14%	0.520	1/2	14.3	14%	0.860	1 1/4	1.46	2 1/4	1 1/2	10	6 1/2	8.49	21.7	1240	173	8.22	192	447	61.2	3.73	92.7	4.17	13.5	7.12	20200
x96	28.1	14.2	14%	0.483	1/2	14.5	14%	0.780	1 1/4	1.28	2 1/4	1 1/2	10	6 1/2	8.54	23.5	1110	157	8.17	173	462	55.2	3.71	83.8	4.14	13.5	5.37	18000
x84	26.6	14.0	14	0.440	1/2	14.5	14%	0.710	1 1/4	1.21	2	1 1/2	10	6 1/2	10.2	25.8	939	142	8.14	157	392	49.9	3.70	75.6	4.11	13.3	4.98	16000
W16x42	74.0	16.3	14%	0.510	1/2	16.1	10%	0.895	1 1/4	1.45	1 1/2	1 1/2	10 1/2	5 1/2	8.90	22.4	381	173	6.05	138	148	28.3	2.48	44.8	2.85	13.8	5.07	6710
x42	71.3	16.2	14%	0.490	1/2	16.1	10%	0.780	1 1/4	1.28	1 1/2	1 1/2	10 1/2	5 1/2	8.41	25.4	295	112	6.04	128	134	26.6	2.48	40.3	2.82	13.4	3.87	5900
x38	20.0	14.0	14	0.418	1/2	16.0	10	0.720	1 1/4	1.21	1 1/2	1 1/2	10 1/2	5 1/2	8.97	27.5	222	109	6.01	115	121	24.2	2.46	36.9	2.80	13.3	3.01	5380
x34	17.9	13.9	13%	0.375	1/2	16.0	10	0.645	1 1/4	1.24	1 1/2	1	10 1/2	5 1/2	7.75	30.4	140	92.1	5.88	102	107	21.5	2.45	32.8	2.79	13.2	2.19	4710
W16x33	15.1	13.8	13%	0.370	1/2	16.0	8	0.680	1 1/4	1.25	1 1/2	1	10 1/2	5 1/2	8.11	30.8	141	77.8	5.89	87.1	87.7	14.3	1.82	32.0	2.22	13.3	1.84	2540
x33	14.1	13.8	13%	0.340	1/2	16.0	8	0.595	1 1/4	1.19	1 1/2	1	10 1/2	5 1/2	8.75	33.8	104	70.2	5.85	78.4	51.4	12.8	1.81	18.8	2.20	13.2	1.45	2340
x31	12.8	13.7	13%	0.305	1/2	16.0	8	0.530	1 1/4	1.12	1 1/2	1	10 1/2	5 1/2	7.54	37.4	125	62.5	5.82	68.5	45.2	11.3	1.80	17.3	2.18	13.1	1.06	1950
W12x58	17.0	12.2	12%	0.380	1/2	10.0	10	0.840	1 1/4	1.24	1 1/2	1 1/2	9 1/2	5 1/2	7.62	27.8	476	78.0	5.28	86.4	107	21.4	2.51	32.5	2.82	11.5	2.10	3570
x58	15.8	12.1	12	0.345	1/2	10.0	10	0.575	1 1/4	1.16	1 1/2	1 1/2	9 1/2	5 1/2	8.88	33.1	425	70.8	5.23	77.5	95.8	18.2	2.46	28.1	2.79	11.5	1.58	3100
W12x50	14.8	12.2	12%	0.370	1/2	10.0	8	0.840	1 1/4	1.14	1 1/2	1 1/2	9 1/2	5 1/2	8.21	28.8	391	64.2	5.18	71.8	88.3	13.9	1.96	21.3	2.25	11.8	1.71	1880
x45	13.1	12.1	12	0.335	1/2	10.0	8	0.575	1 1/4	1.08	1 1/2	1 1/2	9 1/2	5 1/2	7.00	33.8	348	57.7	5.15	64.2	80.0	12.4	1.95	18.0	2.23	11.5	1.26	1650
x40	11.7	11.9	12	0.295	1/2	10.0	8	0.615	1 1/4	1.02	1 1/2	1 1/2	9 1/2	5 1/2	7.77	33.5	307	51.5	5.13	57.0	44.1	11.0	1.94	16.8	2.21	11.4	0.908	1440
W10x112	32.9	11.4	11%	0.795	1/2	10.4	10%	1.25	1 1/4	1.75	1 1/2	1 1/2	7 1/2	5 1/2	4.17	10.4	718	128	4.88	147	256	45.3	2.68	69.2	3.07	10.1	15.1	6020
x112	29.4	11.1	11%	0.880	1/2	10.3	10%	1.12	1 1/4	1.82	1 1/2	1 1/2	7 1/2	5 1/2	4.62	11.5	623	112	4.80	130	207	40.0	2.65	61.0	3.03	10.8	10.8	5150
x100	25.9	10.8	10%	0.805	1/2	10.3	10%	0.980	1	1.45	1 1/2	1 1/2	7 1/2	5 1/2	5.18	13.0	524	98.5	4.84	113	179	34.8	2.63	53.1	2.99	9.88	7.53	4320
x88	22.8	10.6	10%	0.730	1/2	10.2	10%	0.870	1 1/4	1.37	1 1/2	1 1/2	7 1/2	5 1/2	5.88	14.8	455	85.9	4.80	97.8	154	30.1	2.60	45.9	2.95	9.73	5.11	3630
x77	20.0	10.4	10%	0.670	1/2	10.1	10%	0.770	1 1/4	1.27	1 1/2	1 1/2	7 1/2	5 1/2	6.58	16.7	394	75.7	4.64	86.3	134	28.4	2.58	40.1	2.91	9.63	3.98	3100
x66	17.8	10.2	10%	0.620	1/2	10.1	10%	0.680	1 1/4	1.18	1 1/2	1 1/2	7 1/2	5 1/2	7.41	18.7	341	68.7	4.30	74.8	116	23.0	2.57	35.0	2.86	8.54	2.48	2840
x54	15.8	10.1	10%	0.570	1/2	10.0	10	0.615	1 1/4	1.12	1 1/2	1 1/2	7 1/2	5 1/2	8.15	21.2	303	60.0	4.37	68.8	103	20.6	2.56	31.3	2.88	8.48	1.82	2320
x48	14.4	10.0	10	0.540	1/2	10.0	10	0.580	1 1/4	1.08	1 1/2	1 1/2	7 1/2	5 1/2	8.92	23.1	272	54.9	4.35	63.4	93.4	18.7	2.54	28.3	2.84	8.42	1.59	2070

Angles Properties										Angles Properties														
Shape	k	WT	Area, A	Axis X-X					Plastic Section Properties			Axis Y-Y					Axis Z-Z					C _w		
				I	S	r	Z _x	Z _y	J	C _p	Z _x	I	S	r	Z _y	Z _x	I	S	r	Z _y				
				in. ⁴	in. ³	in.	in. ³	in. ³	in. ⁴	in. ³	in. ⁴	in. ³	in. ⁴	in. ³	in. ⁴	in. ³	in. ⁴	in. ³	in. ⁴	in. ³	in. ⁴			
L7x6x1/2	1 1/2	38.2	7.89	37.8	8.38	2.21	2.90	14.8	1.87	1.47	3.87	3.31	0.00	3.01	1.08	1.00	5.80	0.550	5.84	1.71	0.855	0.334	1.00	
x6	1 1/2	22.1	6.46	32.4	7.12	2.23	2.45	12.5	1.80	0.888	2.37	3.34	7.79	2.95	1.10	0.988	4.88	0.484	4.80	1.47	0.860	0.329	1.00	
x6	1	17.9	5.26	28.5	6.79	2.25	2.40	10.2	1.74	0.455	1.35	3.37	6.48	2.10	1.11	0.910	3.77	0.376	3.95	1.21	0.868	0.334	0.985	
x6	3/4	15.7	4.82	23.8	5.11	2.26	2.36	8.03	1.70	0.310	0.951	3.38	5.79	1.88	1.12	0.886	3.31	0.331	3.50	1.08	0.869	0.337	0.912	
x6	1/2	13.6	3.98	20.5	4.42	2.27	2.35	7.81	1.67	0.198	0.544	3.40	5.08	1.81	1.12	0.881	2.84	0.286	3.05	0.942	0.873	0.330	0.840	
L8x6x1	1 1/2	37.4	11.0	35.4	8.55	1.79	1.86	15.4	0.918	3.58	9.34	3.18	35.4	8.85	1.79	1.86	15.4	0.918	15.0	3.53	1.17	1.00	1.00	
x6	1 1/2	33.1	9.75	31.9	7.81	1.81	1.81	13.7	0.815	2.51	6.41	3.21	31.9	7.81	1.81	1.81	13.7	0.813	13.3	3.13	1.17	1.00	1.00	
x6	1 1/4	28.7	8.46	28.1	6.84	1.82	1.77	11.9	0.705	1.81	4.17	3.24	28.1	6.84	1.82	1.77	11.9	0.705	11.5	2.73	1.17	1.00	1.00	
x6	1 1/8	24.2	7.13	24.1	5.84	1.84	1.72	10.1	0.584	0.865	2.30	3.28	24.1	5.84	1.84	1.72	10.1	0.584	9.83	2.32	1.17	1.00	1.00	
x6	1	21.9	6.45	22.0	5.12	1.85	1.70	9.18	0.538	0.704	1.85	3.29	22.0	5.12	1.85	1.70	9.17	0.538	8.94	2.11	1.18	1.00	1.00	
x6	3/4	19.8	5.77	18.9	4.59	1.86	1.87	8.22	0.481	0.607	1.32	3.31	18.9	4.59	1.86	1.87	8.22	0.481	8.04	1.89	1.18	1.00	1.00	
x6	1/2	17.8	5.06	17.5	4.06	1.88	1.85	7.25	0.423	0.340	0.689	3.32	17.8	4.06	1.86	1.85	7.25	0.423	7.11	1.88	1.18	1.00	0.973	
x6	3/8	16.9	4.38	16.4	3.31	1.87	1.82	6.27	0.365	0.218	0.376	3.34	16.4	3.31	1.87	1.82	6.26	0.365	6.17	1.45	1.19	1.00	0.912	
x6	1/4	12.4	3.67	13.0	2.95	1.88	1.80	5.28	0.308	0.129	0.208	3.35	13.0	2.95	1.88	1.80	5.26	0.305	5.20	1.23	1.19	1.00	0.828	

Beam LTB formula's

$$L_p = 1.76 \sqrt{\frac{E}{F_y}} = \frac{300}{\sqrt{F_y}} \text{ ksi}$$

$$L_r = 1.95 r_{tt} \frac{E}{0.7 F_y} \sqrt{\frac{Jc}{S_x h_o}} \sqrt{1 + \sqrt{1 + 6.76 \left(\frac{0.7 F_y S_x h_o}{E Jc} \right)^2}}$$

$$F_{cr} = \frac{C_b \pi^2 E}{(L_b/r_t)^2} \sqrt{1 + 0.078 \frac{Jc}{S_x h_o} \left(\frac{L_b}{r_{tt}} \right)^2}$$

Annexure- 3

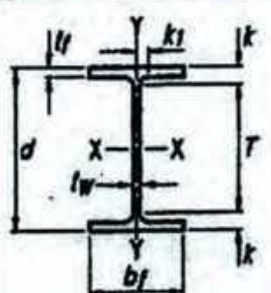

W Shapes Dimensions

Shape	Area, A	Depth, d		Web			Flange				Distance				
				Thickness, tw	tw 2	Width, bf	Thickness, tf	k		k1	T	Work- able Gage			
								kw	kdel				in.	in.	in.
in. ²	in.	in.	in.	in.	in.	in.	in.	in.	in.	in.	in.	in.	in.		
W14x132	38.8	14.7	14 ^{5/8}	0.845	5/8	5/16	14.7	14 ^{3/4}	1.03	1	1.63	2 ^{5/16}	1 ^{9/16}	10	5 ^{1/2}
x120	35.3	14.5	14 ^{1/2}	0.590	9/16	5/16	14.7	14 ^{5/8}	0.940	1 ^{5/16}	1.54	2 ^{1/4}	1 ^{1/2}	↓	↓
x109	32.0	14.3	14 ^{3/8}	0.525	1/2	1/4	14.6	14 ^{5/8}	0.860	7/8	1.46	2 ^{3/16}	1 ^{1/2}	↓	↓
x99 ^f	29.1	14.2	14 ^{1/8}	0.485	1/2	1/4	14.6	14 ^{5/8}	0.780	3/4	1.38	2 ^{1/16}	1 ^{7/16}	↓	↓
x90 ^f	26.5	14.0	14	0.440	7/16	1/4	14.5	14 ^{1/2}	0.710	1 ^{1/16}	1.31	2	1 ^{7/16}	↓	↓

W Shapes Properties



W14 - W12

Nom- inal Wt.	Compact Section Criteria		Axis X-X				Axis Y-Y				r _B	h _o	Torsional Properties	
			I	S	r	Z	I	S	r	Z			J	C _w
	lb/ft	bt 2t	h tw	in. ⁴	in. ³	in.	in. ³	in. ⁴	in. ³	in.	in. ³	in.	in.	in. ⁴
132	7.15	17.7	1530	209	6.28	234	548	74.5	3.76	113	4.23	13.6	12.3	25500
120	7.80	19.3	1380	190	6.24	212	495	67.5	3.74	102	4.20	13.5	9.37	22700
109	8.49	21.7	1240	173	6.22	192	447	61.2	3.73	92.7	4.17	13.5	7.12	20200
99	9.34	23.5	1110	157	6.17	173	402	55.2	3.71	83.6	4.14	13.4	5.37	18000
90	10.2	25.9	999	143	6.14	157	362	49.9	3.70	75.6	4.11	13.3	4.06	16000

University of Asia Pacific
Department of Civil Engineering
Final Examination Fall 2014
Program: B.Sc. Engineering (Civil)

Course Title: Structural Engineering IX
(Earthquake Resistant Design and Retrofitting)
Time: 2 Hours

Course Code: CE 423

Full Marks: 100

There are 7 (Seven) questions. Answer any 5 (Five)

1. a) Define undamped, critically damped and overdamped systems. Derive equation of motion of free vibration of an underdamped SDOF system. (11)
- b) The free vibration of an undamped system is shown below in *Figure 1*. Calculate its (i) undamped natural period, (ii) undamped natural frequency in Hz and radian/second, (iii) stiffness if its mass is $2 \text{ lb-sec}^2/\text{ft}$. (9)

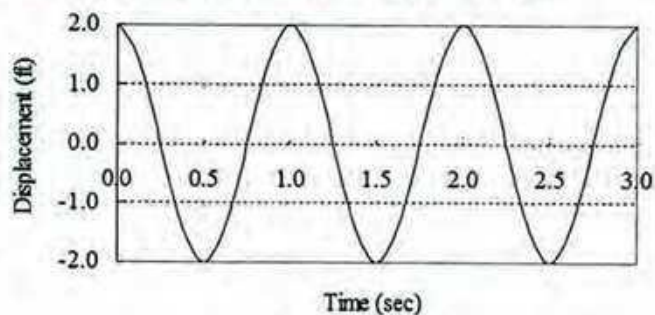

Figure 1

2. a) What are the effects of soil condition on isolated structure? (3)
- b) A 16 in wide and 20 in deep (including 5 in slab) reinforced concrete beam spans between two interior columns (*Figure 2*) in a building frame designed for a region of high seismic risk. (12)

The clear span of the beam is 22 ft and the reinforcement at the face of the support consists of four No. 9 top bars and four No. 8 bottom bars, each in one layer.

Design the shear reinforcement for the regions adjacent to the column faces for $DL = 1.2 \text{ kip/ft}$ and $LL = 1.4 \text{ kip/ft}$.
Given $f'_c = 3000 \text{ psi}$ and $f_y = 60000 \text{ psi}$.

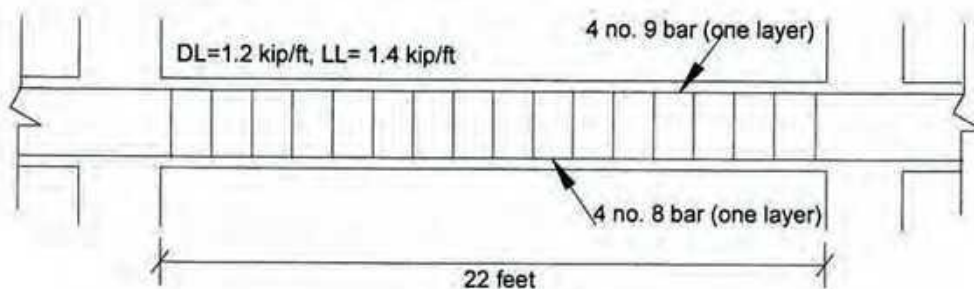
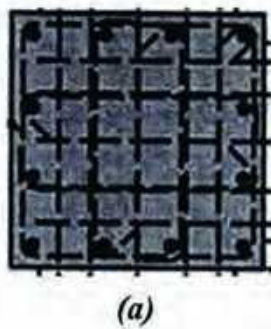

Figure 2

- (c) Explain how degree of confinement effects the nominal shear capacity of beam-column joints. (5)
3. a) What is seismic base isolation system? What are the characteristics of a well-designed seismic base isolation system? (8)
- b) Write short notes on: (i) Resonance, (ii) Spherical sliding bearing. (6)
- c) What is liquefaction? Explain how it takes place during earthquake. (6)
4. a) Write short notes on: (i) Anchorage, (ii) Development length. (6)
- b) What are the requirements for concrete and steel reinforcement for earthquake resistant design? (4)
- c) Determine the minimum transverse reinforcement of the column (*Figure 3*) required over length l_0 . Show the reinforcement detailing in neat sketch. (10)



Column Size
36 in x 36 in

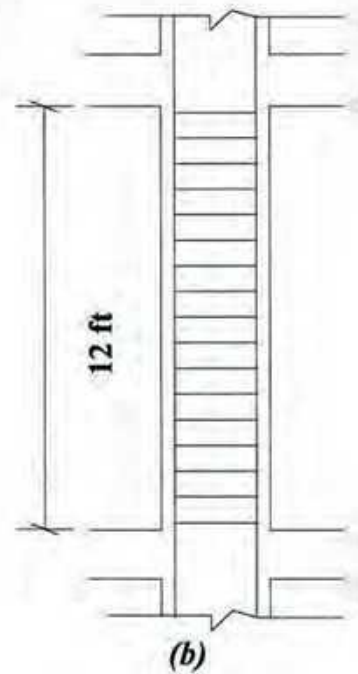

Figure 3

5. a) What assumptions are made in calculating the flexural resistance of a section strengthened with an externally applied FRP system? (8)
- b) What are the failure modes of FRP strengthened flexural member as per ACI. (5)
- c) "Confinement of circular column is better than confinement in rectangular column", Explain why? (4)
- d) Explain how concrete surface should be prepared before retrofitting. (3)
6. a) What are the main causes of deterioration of RC structures in Bangladesh? Discuss the problems that occur commonly during RC construction works in Bangladesh. (12)
- b) Explain concrete crack sealing by injection method. (4)

- c) Explain possible reasons for the cracks in RC beams and columns shown in *Figure 4*. (4)

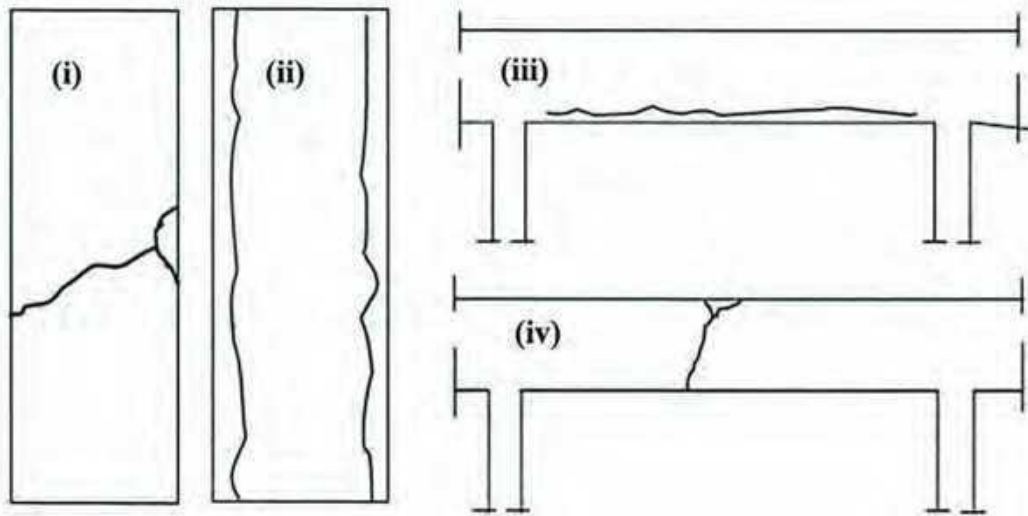

Figure 4

7. a) Why unreinforced masonry (URM) structures are vulnerable to earthquake? (8)
What steps should an engineer take to avoid failure of URM structures due to earthquake?
- b) Write short notes on: (i) Primer, (ii) Adhesive, (iii) FRP (6)
- c) Narrate the repair methods of the cracks shown in the brick walls in *Figure 5*. (6)

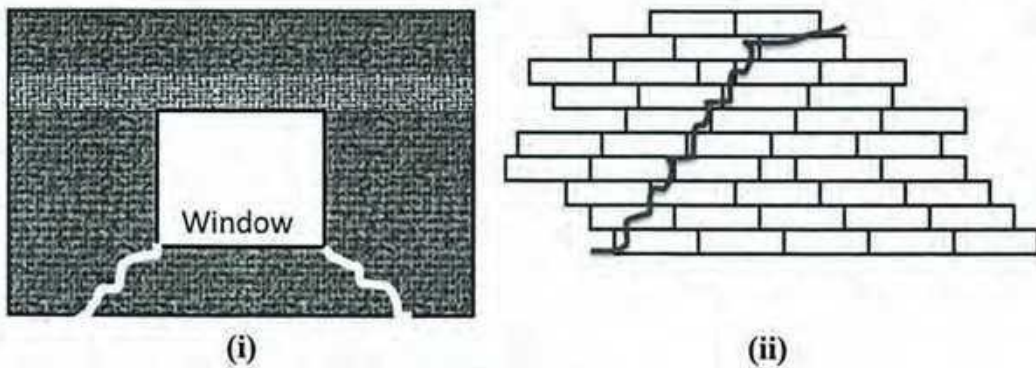

Figure 5

University of Asia Pacific
Department of Civil Engineering
Final Examination Fall 2014
Program: B. Sc. Engineering (Civil)

Course Title: Environmental Engineering III
Time- 2 hours

Course Code: CE 431
Full marks: 100

Question no. 6 is mandatory. Answer any **FOUR (4)** from question no. 1-5. (5 X 20 = 100)
(Assume any missing data)

1. (a) Define a hazardous waste emphasizing its characteristics. [5]
(b) Show in a schematic diagram/flowchart, the different ways that humans can be exposed to hazardous waste. [5]
(c) Consider you are an Engineer who works for an industry in Bangladesh that has a lot of toxic chemicals waste to dispose of as part of the manufacturing process. Being established in a developing country, list the general problems that you will expect in the treatment and disposal of this special category of waste. Also state what option would you choose for disposal of this waste? Lastly, as part of your assignment, what are the factors that you would have to consider if the company asks you to cite a landfill site for this type of waste? [10]
2. (a) What are the advantages and the challenges of composting process? [6]
(b) How is the anaerobic digestion process that occurs inside a digester (closed reactor) different than the anaerobic digestion when it occurs inside a landfill? State the names of at least three organizations that have implemented biogas technology in Bangladesh. [6]
(c) Estimate the theoretical requirement of air for composting of the organic waste having the structural formula $C_{40}H_{100}O_{30}N$. [8]
3. (a) Why is transfer station important in solid waste management system? [5]
(b) Which steps/elements are included in the consideration of economic costs of the solid waste collection? [5]
(c) A transfer station was built with an installation cost of 5,00,000 BDT with yearly operational cost being 50,000 BDT. The transfer station is meant to handle 500 tons/day operating 7 days a week. To be operated to and from the transfer station, a tractor-trailer was bought with 1,00,000 BDT which will require 10,000 BDT for yearly operation and maintenance. The truck carries 50 tons/trip. A driver appointed would require 4,000 BDT

per month including benefits. The capital cost of the building and transfer trucks are to be amortized over a 20 year period using a 10% discount factor. Suppose it takes 45 minutes to make a one-way trip from the transfer station to the disposal site and 5 round trips per day are made. Find the total cost of transfer station and hauling cost in BDT per ton. Plot the result showing the fixed cost and the variable cost varying over time.

4. (a) What is industrial waste? Provide examples of industrial waste and explain how these wastes can be treated? [7]
- (b) Distinguish between Resource Recovery by Material Separation and Resource Recovery by Material Conversion. [4]
- (c) A tannery in Hazaribagh dumps waste every day @ a rate of 50 tons per day into a nearby river except Friday. Also, there is no waste collection system available in the surrounding residential area that generates 0.1 tons per capita per day with 1500 people and the ultimate destination for these waste also is the same river beside tannery. If a waste collection vehicle to be bought for collecting the residential waste costs 50,000 BDT requiring 2 crew members with 10 BDT/hour wage rate @8 working hours/day for 7 days a week, calculate the cost of the total waste collection system for one year (no amortization required; consider yearly operational cost to be 5,000 BDT) if it is to be implemented in the area. Also calculate the total amount of waste that the river is receiving every month when there is no collection system available. [9]
5. (a) What is leachate and what is it composed of? How can leachate be controlled? What are the key components of leachate management? [3+3 = 6]
- (b) Draw the landfill gas generation profiles. [6]
- (c) A refuse has the following components and bulk densities: [8]

Component	Percentage by Weight	Uncompacted bulk density (lb/ft ³)
Newspaper	40	3.81
Garden waste	35	4.45
Glass	25	18.45

Assume that the compaction in the landfill is 44 lb/ft³. Estimate the % volume reduction achieved during compaction of the waste. Estimate the overall uncompacted bulk density if the garden waste is removed.

6. (a) Explain why sanitary landfill is an easily applicable option for waste disposal. [3]

(b) Design a sanitary landfill that will be built in a flat area which will be used ultimately for construction purpose after 20 years i.e. the land is being taken through lease by the Govt. Answer according to the steps given below: [17]

- i) State the general steps or factors that you will consider while selecting the area
- ii) Choose the type of method of landfilling
- iii) Mention a leachate management system
- iv) State the advantages/disadvantages of the site that you chose and the method that you selected for the area
- v) Calculate the required landfill capacity for the current year for a population size of 30,00,000 with per capita waste generation rate of 5.0 lb/capita/day and compacted density of 40 lb/ft³. Assume that the daily cover consists of 10% of the landfill volume.
- vi) State how you can make the landfill environmentally friendly

Given Formulae:

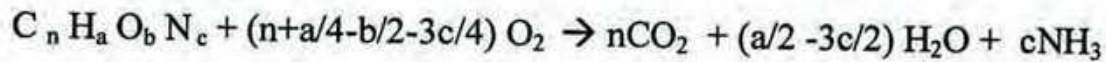

$$A = P \left[\frac{i(1+i)^n}{(1+i)^n - 1} \right]$$

$$CRF = \left[\frac{i(1+i)^n}{(1+i)^n - 1} \right]$$

Where, A = Annual cost (BDT/yr)

P = Purchase price, (BDT)

i = interest rate, discount rate (yr⁻¹)

n = amortization period (yr)

CRF = Capital Recovery factor

University of Asia Pacific
Department of Civil Engineering
Final Examination Fall 2014
Program: B. Sc. Engineering (Civil)

Course Title: Environmental Engineering IV
Time: 2 hour

Course Code: CE 433
Full marks: 100 (= 4×25)

[ANSWER ALL PARTS (i.e. a, b) OF EACH QUESTION TOGETHER]

(Note: Assume reasonable value for any missing data)

(The symbols have their usual meaning)

Answer any FOUR questions out of FIVE.

1. (a) On March, 4, 2015, the following air quality data have been recorded at CAMS (Continuous Monitoring Stations/Systems) in Dhaka. (10)
 $PM_{2.5} = 150 \mu\text{g}/\text{m}^3$ (24 hr)
 $PM_{10} = 180 \mu\text{g}/\text{m}^3$ (24 hr)
 $O_3 = 0.200$ ppm (1 hr)
Calculate Air Quality Index (AQI) for that day. Also, prepare the AQI report.
- (b) Briefly explain – (i) Criteria pollutant, (ii) Air toxin, (iii) Lofting plume, (iv) Fumigating plume and (v) Fanning Plume (15)
2. (a) A stack emitting 70 g/s of SO_2 has an effective stack height of 200 m. The wind speed is 3 m/s at 10 m, and it is a cloudy summer day. Estimate the ground level SO_2 concentration – (12)
(i) directly downwind at a distance of 1.5 km
(ii) at a point located 1.5 km downwind and 0.5 km of cross- downwind axis
(iii) at a point downwind where SO_2 is maximum
- (b) (i) Briefly describe the approaches for engineering control of air pollutants. (6)
(ii) Explain the effects of air-fuel ratio on pollution with relevant figure. (7)
3. (a) A lake of $150 \times 10^4 \text{ m}^2$ area is being fed by a stream flow of $10 \text{ m}^3/\text{s}$. Phosphorus (P) concentration in the stream water is $0.0004 \text{ g}/\text{m}^3$. The lake also receives a wastewater flow of $0.5 \text{ m}^3/\text{s}$, which contain $11.0 \text{ mg}/\text{L}$ ($= 11.0 \text{ g}/\text{m}^3$) of phosphorus. P settling rate is given by $10 \text{ m}/\text{yr}$ ($= 3.17 \times 10^{-7} \text{ m}/\text{s}$). (10)
(i) Estimate average P concentration in the lake.
(ii) Estimate P removal rate at the treatment plant to keep P concentration below $0.02 \text{ mg}/\text{L}$.
- (b) (i) What is eutrophication? Briefly explain the classification of lakes from the viewpoint of eutrophication. (6)
(ii) Briefly describe the layers in a lake due to availability of sunlight, with necessary figure. (4)
(iii) What are the principal controlling factors for eutrophication? (5)

4. (a) A city discharges $1500 \text{ m}^3/\text{d}$ of sewage into a stream whose minimum rate of flow is $5.0 \text{ m}^3/\text{s}$. The velocity of stream is 5 m/s . The temperature of the sewage is 20°C and that of the water stream is 15°C . The 20°C BOD_5 of the sewage is 190 mg/L and that of the stream water is 1 mg/L . The sewage contains no DO while the stream is 90% saturated with dissolved oxygen. The values of K_d and K_r at 20°C are $0.25/\text{d}$ and $0.65/\text{d}$ respectively. Use the temperature coefficient of 1.047 for K_d and 1.024 for K_r . Determine: (12)
- (i) The maximum oxygen deficit, critical (minimum) DO and its location.
 - (ii) Sketch the DO profile for a 150-km reach of the stream below the discharge. Attach the graph paper with your answer script.
- (b) (i) What are the source and sink of DO in river to be considered for Streeter-Phelps DO model? Also mention the assumptions to be made for the model. (5)
- (ii) What are the drawbacks of Streeter-Phelps oxygen-sag curve? (3)
- (iii) Explain the effects of – (i) temperature and (ii) NBOD on DO sag curve with relevant figures. (5)
5. (a) Briefly explain the effects of oxygen demanding waste on river water quality. (3)
- 30 mL wastewater is mixed with dilution water to fill 300 mL BOD bottle. The drop of DO after 5 days is 4.8 mg/L . For a BOD bottle filled with only dilution water, DO drop is 1.2 mg/L after 5 days. If $k = 0.21 \text{ d}^{-1}$ at 20°C , what is the CBOD remaining after 5 days? (10)
- Again, the total concentration of organic and ammonia nitrogen in the wastewater is 25.0 mg/L . Estimate the ultimate strength of the sample.
- (b) What are the problems associated with eutrophication? Explain the mechanisms of eutrophication control. (8)
- Explain why river water quality becomes worse during summer months. (4)

Formulae:

$$I_p = \frac{I_{Hi} - I_{Lo}}{BP_{Hi} - BP_{Lo}} (C_p - BP_{Lo}) + I_{Lo}$$

$$\sigma_y = ax^{0.894}, \quad \sigma_z = cx^d + f$$

$$C(x, y, z) = \frac{Q}{2\pi u \sigma_y \sigma_z} \times \exp\left(\frac{-y^2}{2\sigma_y^2}\right) \left[\exp\left(-\frac{(z-H)^2}{2\sigma_z^2}\right) + \exp\left(-\frac{(z+H)^2}{2\sigma_z^2}\right) \right]$$

$$C_{\max} = \frac{Q}{u} \times \frac{C_u}{Q_{\max}}$$

$$BOD_t = L_0 (1 - e^{-kt})$$

$$P = \frac{S}{Q + v_s \cdot A}$$

$$D = \frac{k_d L_0}{k_r - k_d} (e^{-k_d t} - e^{-k_r t}) + D_0 e^{-k_r t}$$

$$k_r = \frac{3.9u^{1/2}}{H^{3/2}} \quad t_c = \frac{1}{k_r - k_d} \ln \left[\frac{k_r}{k_d} \left(1 - \frac{D_0 [k_r - k_d]}{k_d \cdot L_0} \right) \right]$$

$$D_{\max} = \frac{k_d L_0}{k_r - k_d} (e^{-k_d t_c} - e^{-k_r t_c}) + D_0 e^{-k_r t_c}$$

$$DO_{(sat)} = 14.62 - 0.39 T + 0.007714 T^2 - 0.0000646 T^3$$

$$k_d (\text{at } T^\circ\text{C}) = k_{20^\circ\text{C}} \cdot (1.047)^{T-20}, \quad k_r (\text{at } T^\circ\text{C}) = k_{20^\circ\text{C}} \cdot (1.024)^{T-20}$$

$$BOD_m \cdot V_m = BOD_w \cdot V_w + BOD_d \cdot V_d$$

Breakpoints							AQI	Category
O ₃ (ppm) 8-hr	O ₃ (ppm) 1-hr (i)	PM _{2.5} (µg/m ³) 24-hr	PM ₁₀ (µg/m ³) 24-hr	CO (ppm) 8-hr	SO ₂ (ppm) 24-hr	SO ₂ (ppm) Annual		
0.000-0.064	---	0.0-15.4	0-54	0.0-4.4	0.000-0.034	(ii)	0-50	Good
0.065-0.084	---	15.5-40.4	55-54	4.5-9.4	0.035-0.144	(ii)	51-100	Moderate
0.085-0.104	0.125-0.164	40.5-65.4	155-254	9.5-12.4	0.145-0.224	(ii)	101-150	Unhealthy for sensitive group
0.105-0.124	0.165-0.204	65.5-150.4	255-354	12.5-15.4	0.225-0.304	(ii)	151-200	Unhealthy
0.125-0.374	0.205-0.404	150.5-250.4	355-424	15.5-30.4	0.305-0.604	0.65-1.24	201-300	Very unhealthy
(iii)	0.405-0.504	250.5-350.4	425-504	30.5-40.4	0.605-0.804	1.25-1.64	301-400	Hazardous
(iii)	0.505-0.604	350.5-500.4	505-604	40.5-50.4	0.805-1.004	1.65-2.04	401-500	Hazardous

(i) In some cases, in addition to calculating the 8-hr ozone index, the 1-hr ozone index may be calculated and the maximum of the two values is reported

(ii) NO₂ has no short term air quality standard and can generate an AQI only above 200

(iii) 8-hr O₃ values do not define higher AQI values (≥ 301). AQI values of 301 or higher are calculated with 1-hr O₃ concentrations.

Surface wind speed ^a (m/s)	Day solar insolation			Night cloudiness ^e	
	Strong ^b	Moderate ^c	Slight ^d	Cloudy (≥ 4/8)	Clear (≤ 3/8)
< 2	A	A-B	B	E	F
2-3	A-B	B	C	E	F
3-5	B	B-C	C	D	E
5-6	C	C-D	D	D	D
> 6	C	D	D	D	D

^aSurface wind speed is measured at 10 m above the ground.

^bCorresponds to clear summer day with sun higher than 60° above the horizon.

^cCorresponds to a summer day with a few broken clouds, or a clear day with sun 35-60° above the horizon.

^dCorresponds to a fall afternoon, or a cloudy summer day, or clear summer day with the sun 15-35° above the horizon.

^eCloudiness is defined as the fraction of sky covered by clouds.

^fFor A-B, B-C, or C-D conditions, average the values obtained for each.

Note: A, Very unstable; B, moderately unstable; C, slightly unstable; D, neutral; E, slightly stable; F, stable. Regardless of windspeed, class D should be assumed for overcast conditions, day or night.

Source: Turner (1970).

TABLE 7.7 WIND PROFILE EXPONENT p FOR ROUGH TERRAIN*

Stability class	Description	Exponent, p
A	Very unstable	0.15
B	Moderately unstable	0.15
C	Slightly unstable	0.20
D	Neutral	0.25
E	Slightly stable	0.40
F	Stable	0.60

Handwritten notes: "best" with arrow pointing to A, B, C; "neutral" with arrow pointing to D; "worst" with arrow pointing to E, F.

* For smooth terrain, multiply p by 0.6; see Table 7.8 for further descriptions of the stability classifications used here.

Source: Peterson (1978).

Stability	$x \leq 1 \text{ km}$				$x \geq 1 \text{ km}$		
	a	c	d	f	c	d	f
A	213	440.8	1.941	9.27	459.7	2.094	-9.6
B	156	106.6	1.149	3.3	108.2	1.098	2.0
C	104	61.0	0.911	0	61.0	0.911	0
D	68	33.2	0.725	-1.7	44.5	0.516	-13.0
E	50.5	22.8	0.678	-1.3	55.4	0.305	-34.0
F	34	14.35	0.740	-0.35	62.6	0.180	-48.6

* The computed values of σ will be in meters when x is given in kilometers.

Source: Martin (1976).

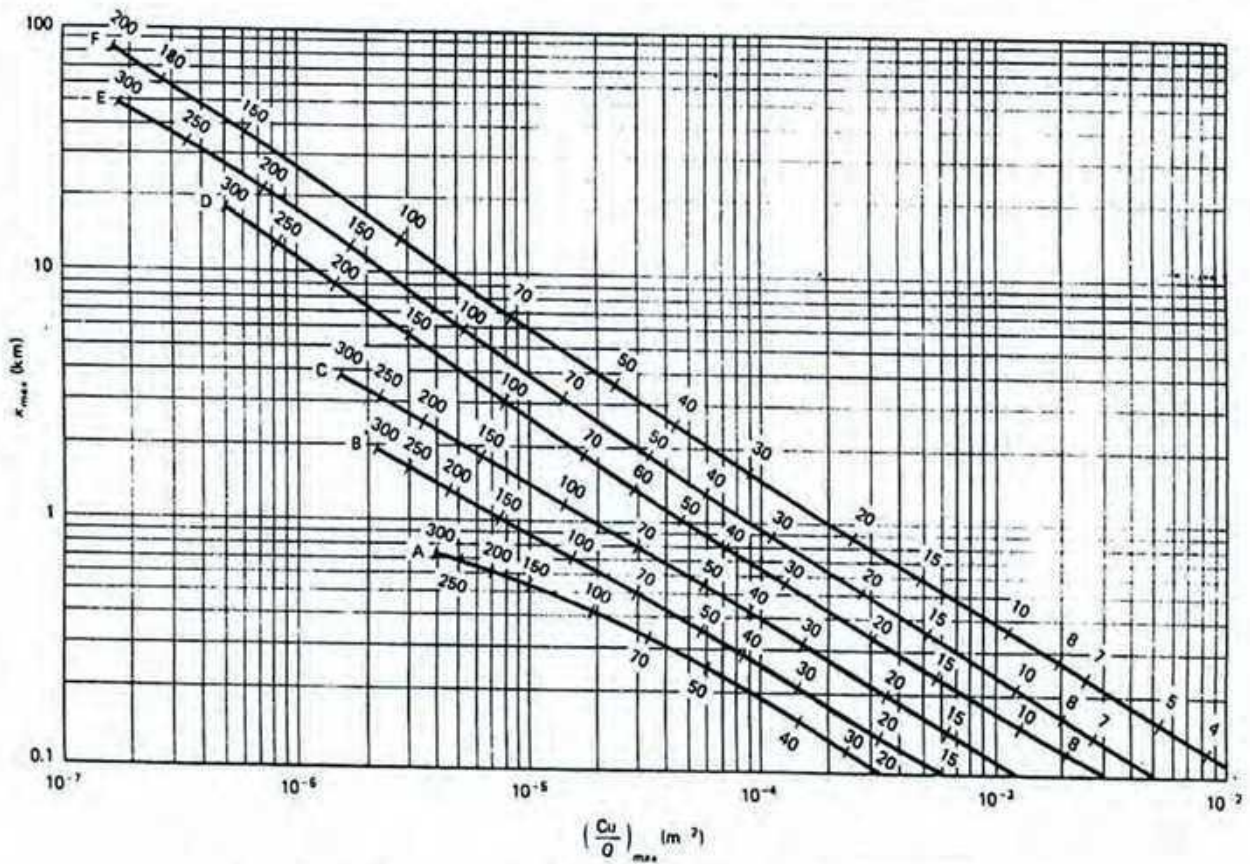

Figure 7.30 To determine the peak downwind plume concentration, enter the graph at the appropriate stability classification and effective stack height (numbers above the lines, in meters) and then move across to find the distance to the peak, and down, to find a parameter from which the peak concentration can be found (Turner, 1970).

University of Asia Pacific
Department of Civil Science and Engineering
Semester Final Examination, Fall-2014
Program: B.SC Engineering (2nd Year/2nd Semester)

Course Title: Principle of Economics

Course Code: ECN 201

Credit: 2.00

Time: 2 Hours

Full Marks: 50

Answer any **five** from the following questions:

1. (a) What are the features of monopoly ? Explain deadweight loss with a diagram. (6)

(b) In case of a monopolist: $P= 200-4Q$, $TC= 5Q+4$ (4)

Find out the profit maximizing price and quantity.

2. (a) Calculate Nominal GDP, Real GDP, GDP Deflator : Here, Base Year = 2010 (6)

Year	Price of X	Quantity of X	Price of Y	Quantity of Y
2010	240	25	210	30
2013	265	30	300	36

i. Estimate the Nominal GDP for 2010 and 2013. ii. What is the Real GDP in 2013?

iii. Find the GDP deflator for 2013

(b) What are the differences between GDP Deflator and CPI? Define: GDP Deflator. (4)

3. How can economy revive itself after recession? What kind of policies should be taken to tackle the problem of recession? Explain (10)

4. What is inflation? Explain the reasons behind inflation (10)

5. (a) Suppose price of a consumer basket of goods in year 2000=160 and in 2010=235. Find the CPI in 2010. What is the inflation rate for 2010? [Base Year= 2000] (5)

(b) What are the consequences of inflation? Explain. (5)

6. Explain different types of unemployment. (10)

University of Asia Pacific
Department of Civil Engineering
Final Examination Fall 2014
Program: B.Sc. Engineering (Civil)

Course title: Environmental Engineering VII
Time: 120 minutes

Course code: CE 439
Full marks: 50

There are SIX (6) questions. Answer question no. 01 (COMPULSORY) and any THREE (3) from the rest.

1. A) Define the following: 8
- Environmental Impact Assessment (EIA)
 - Screening
 - Environmental policy
 - Impact analysis
 - Impact mitigation
 - Environmental management plan
 - EIA review
 - Environmental Auditing
- B) Draw the flow diagram of EIA process and parallel studies. 6
2. A) According to the Bangladesh Environmental Conservation Rules (1997), write seven factors that should be considered while declaring any area as *ecologically critical area*. 3
- B) According to Article 7 of the Bangladesh Environmental Conservation Rules (1997), write the procedures to obtain environmental clearance certificate for a red category factory. 6
- C) Explain four main types of social impacts. 3
3. Write the name of your own group work's project.
- One of the following projects: a) Rampal Thermal Power Plant b) Padma Multipurpose Bridge Project c) Deep Sea Port in Sonadia
- A) Identify the three most important impacts of your project. Write only the names. 1
- B) Graphically show the time versus impact significance of these three impacts at different phases of your specific project. Draw three different figures for three selected impacts. 8

(Examples of different phases of the project are: *before the project started, at planning/initiation phase, at implementation/construction phase and at operational*

phase/after construction phase etc.)

- C) According to Environmental Conservation Rules (1997) of Bangladesh, in which category the following industrial units and projects can be classified (i.e. Green, Orange A, Orange B, Red)? 3

Industrial Unit/Project	Category
Tea processing	
Medical and surgical instruments (excluding production)	
Dry-cleaning	
Power plant	

4. A) What are the typical parameters (impact characteristics) that need to be taken into account for impact prediction and decision-making in an EIA process? 4
- B) Produce an EIA sample impact identification checklist for your own group work's project. 8

For one of the following projects a) Rampal Thermal Power Plant b) Padma Multipurpose Bridge Project c) Deep Sea Port in Sonadia

5. A) Explain the three steps process (or main elements) of impact mitigation. 4
- B) A University is proposing to construct a new residential campus in Gazipur in an area covering 100 acres. After completion, the new campus will accommodate around 2500 students, staffs and faculties. There will be two residential halls, where around 800 students will reside. The area proposed for the new campus is located in an area mainly used for agriculture and there is a river nearby. 8

For this project, write the benefits of public participation during EIA process for the following stakeholder groups (**write four benefits for each stakeholder group**):

- The proponent/supporter
- The decision-maker
- Affected communities

6. A) Elaborately explain six different components of Environmental Management Plan (EMP). 5
- B) Explain the main steps of EIA review. 3
- C) Graphically show three different steps of Environmental Auditing (EA). 4