

University of Asia Pacific
Department of Civil Engineering
Midterm Examination (Fall 2014)
Program: B.Sc. Engg (3rd year 1st semester)

Course Title: Principles of Accounting
 Time : 1 hr

Course: ACN 301

Credit Hours: 2.0
 Full marks : 20

[Answer all Questions]

Q.1. At the end of its first month of operations, Darth Vader Builders Ltd. has the following adjusted trial balance on December 31, 2013. (in '000BDT)

	<u>Debit</u>	<u>Credit</u>
Cash	11,400	
Accounts Receivable	6,370	
Prepaid Insurance	1,950	
Supplies	750	
Equipment	30,000	
Unearned Revenue		8,000
Accounts Payable		12,350
Darth Vader, Capital		22,000
Darth Vader, Drawing	600	
Service Revenue		14,370
Salaries Expense	2,200	
Travel Expense	1,300	
Rent Expense	1,200	
Misc. Expense	200	
Supplies Expense	300	
Depreciation Expense	500	
Accumulated depreciation-Equipment		500
Interest Expense	300	
Interest Payable		300
Insurance Expense	450	
Total	57,520	57,520

Instructions:

- a) Prepare an Income Statement for the month ended December 31, 2013.
- b) Prepare an Owner's Equity Statement for the month ended December 31, 2013. (4+4=8)

Q.2. On September 1, 2014 the account balances of Thao Consultants Ltd. were as follows: (in '000BDT)

	<u>Debit</u>	<u>Credit</u>
Cash	2,790	
Accounts Receivable	2,510	
Supplies	2,000	
Store Equipment	10,000	
Accumulated Depreciation		500
Accounts Payable		2,100
P. Thao, Capital		12,800
Unearned Service Revenue		1,400
Salaries Payable		500
Total	17,300	17,300

(PTO)

During September the following summary transaction were completed: (in '000BDT)

- Sep 02 : Paid BDT 1100 for salaries due employees, of which BDT 600 is for September.
- Sep 10 : Received BDT 1200 cash from customers on account.
- Sep 12 : Received BDT 1400 cash for service performed in September.
- Sep 15 : Purchased store equipment on account BDT 3000.
- Sep 17 : Purchased supplies on account BDT 1500.
- Sep 20 : Paid creditors on account BDT 2500.
- Sep 22 : Paid September rent BDT 300.
- Sep 27 : Performed services on account and billed customers for services rendered BDT 900.
- Sep 29 : Received BDT 550 from customers for future service.

Additional data for adjustments consist of: (in BDT '000):

- a) Supplies on hand BDT 1600.
- b) Depreciation is BDT 120 per month.
- c) Unearned service revenue of BDT 1250 is earned.

Instructions:

- (a) Journalize the September transactions.
- (b) Journalize adjusting entries.

(9+3=12)

University of Asia Pacific
Department of Civil Engineering
Mid Term Examination Fall 2014
Program: B.Sc. Engineering (Civil)

Course Title: Design of Concrete Structures II
 Time: 1 hr

Course Code: CE 317
 Full Marks: 2x15=30

(B)

[Answer all the questions]

1. a) What are corner reinforcements in two-way slabs? Mention the ACI provisions for corner reinforcements. (5)

b) Design the **panel D (Interior Panel)** of a flat slab of size 20' x 15' c/c (supported on 12" x 10" edge beams) as shown in Fig. if it carries FF = 20 psf, RW = 20 psf, LL = 40 psf

[Given: $f_c' = 3$ ksi, $f_y = 40$ ksi, $f_{c,all} = 1.35$ ksi, $f_{s,all} = 18$ ksi, $k=0.403$, $j=0.866$,

$M = A_s f_y j d$, $A_{stemp} = 0.036t$ (Use all formula given on the back)

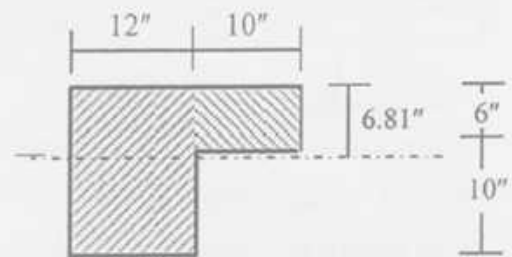
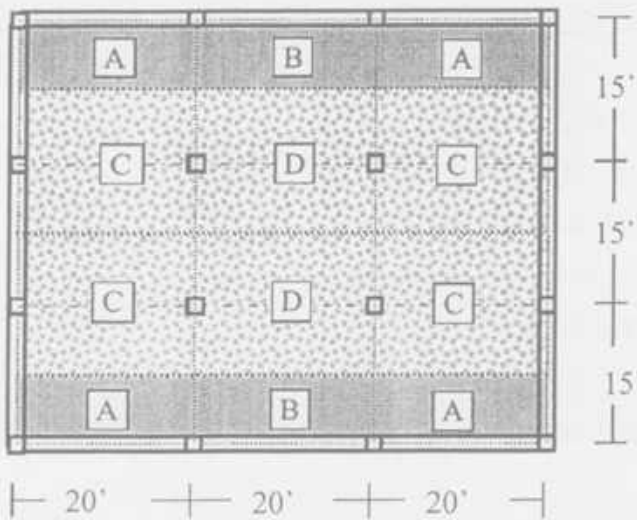

Fig. 2.9: Effective beam with portion of slab

2. (a) Mention the ACI recommendations for the size, spacing and arrangement of lateral ties and spirals. (5)
- (b) Use (i) WSD, (ii) USD to design tied square column sections for applied compressive force of 240 kips and 680 kips, assuming steel ratio $\rho_s = 0.04 = 4\%$ [Given: $f_c' = 4.5$ ksi, $f_y = 55$ ksi, $f_{s,all} = 22$ ksi]. (10)

List of Useful Formulae for CE 317

Column-Supported Slabs

* Minimum Slab thickness for flat slab with Edge Beam (Interior Panel) = $L_n/36$ (for 40 ksi)

* Total Static Moment at Factored Loads, $M_0 = w_n L_2 L_n^2 / 8$

* Total static moment for interior spans: $M_u^{(+)} = 0.65 M_0$, $M_u^{(-)} = 0.35 M_0$

* Distribution Factors applied to Static Moment M_0 for Positive and Negative Moments

Position of Moment	Interior Span	Ext Edge unrestrained (a)	Slab with beams between all supports (b)	No beam between interior supports		Exterior Edge fully restrained (e)
				Without edge beam (c)	With edge beam (d)	
Exterior $M^{(-)}$	NA	0.00	0.16	0.26	0.30	0.65
Interior $M^{(-)}$	0.65	0.75	0.70	0.70	0.70	0.65
$M^{(+)}$	0.35	0.63	0.57	0.52	0.50	0.36

$$* \alpha = E_{cb} I_b / E_{cs} I_s \quad * \beta_i = E_{cb} C / 2 E_{cs} I_s \quad * C = \sum (1 - 0.63 x/y) x^3 y / 3$$

$$\% \text{ of Exterior } M^{(-)} \text{ supported by Column Strip} = 100 - 10\beta_i + 12\beta_i (\alpha_1 L_2 / L_1) (1 - L_2 / L_1)$$

$$\% \text{ of } M^{(+)} \text{ supported by Column Strip} = 60 + 30 (\alpha_1 L_2 / L_1) (1.5 - L_2 / L_1)$$

$$\% \text{ of Interior } M^{(-)} \text{ supported by Column Strip} = 75 + 30 (\alpha_1 L_2 / L_1) (1 - L_2 / L_1)$$

$$\text{For no longitudinal beam} = \alpha_1 L_2 / L_1 = 0; \text{ No Transverse beam} = \beta_i = 0$$

$$* A_v = (V_n - V_c) / (f_y \sin \alpha) \quad * S = A_v f_y d / (V - V_c)$$

$$* V_c = 4 \sqrt{f'_c} b_o d \quad * V_c = (2 + 4/\beta_c) \sqrt{f'_c} b_o d \quad * V_c = (2 + \alpha_s d / b_o) \sqrt{f'_c} b_o d \quad [\text{Use half of the values for WSD}]$$

Short Column

$$* P_n = 0.85 f'_c A_c + f_y A_s = A_g [0.85 f'_c + \rho_s (f_y - 0.85 f'_c)]$$

$$\text{For USD, } * P_u = \alpha \phi A_g [0.85 f'_c + \rho_s (f_y - 0.85 f'_c)]$$

$$\alpha = 0.80, \phi = 0.70$$

$$\text{For WSD } * P_{all} = \phi' (0.25 f'_c A_g + f_{sall} A_s) = \phi' A_g (0.25 f'_c + \rho_s f_{sall})$$

$$\phi' = 0.85$$

$$* \rho_s = 0.45 (A_g / A_{core} - 1) (f_c / f_y) \quad * S = 4 A_{sp} / (\rho_s d_{core})$$

University of Asia Pacific
Department of Civil Engineering
MidTerm Examination
Fall 2014
Program: B.Sc. Engineering (Civil)

Course Title: Engineering Mechanics I
Time: 1 hour

Course Code: CE 101
Full Marks: 20

Answer all the questions.

(4x5=20 marks)

1. In Figure 1, calculate the resultant (magnitude and direction) of the following coplanar concurrent force system. 5

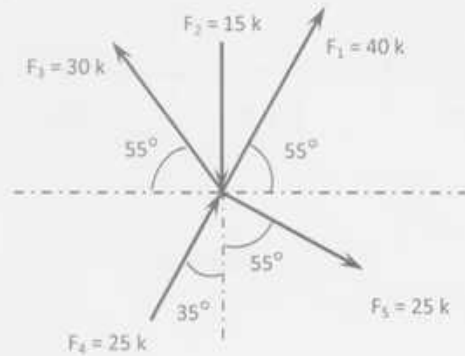

Figure 1

2. In Figure 2, find the reactions at A and B. Given that $W_{\text{SPHERE}} = 750 \text{ lb}$ (assume all surfaces smooth and frictionless). 5

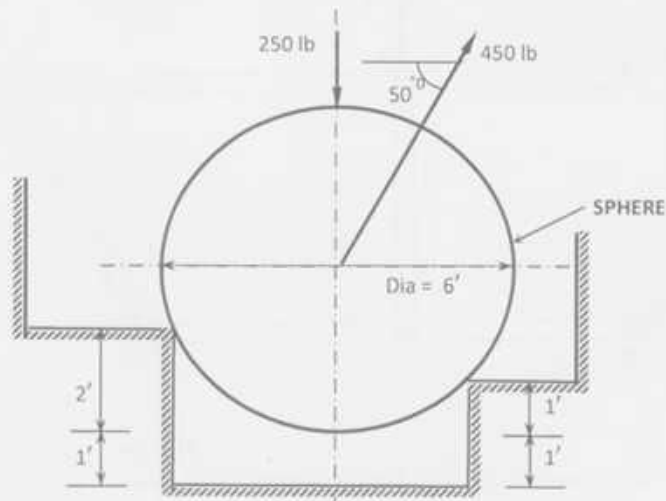

Figure 2

3. Determine the reactions at the supports of the beam as shown in Figure 3.

5

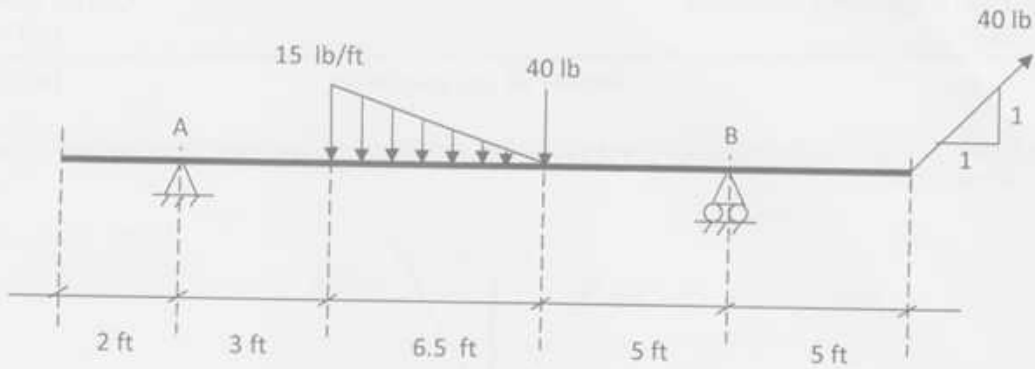

Figure 3

4. The frame shown in the following consists of two horizontal members (AC and DG), which are connected by two members (BE and CG). All the members have been assumed to be weightless.

- Identify the two force member(s).
- Calculate the reactions at A and D.
- Calculate the forces in member BE and CG.

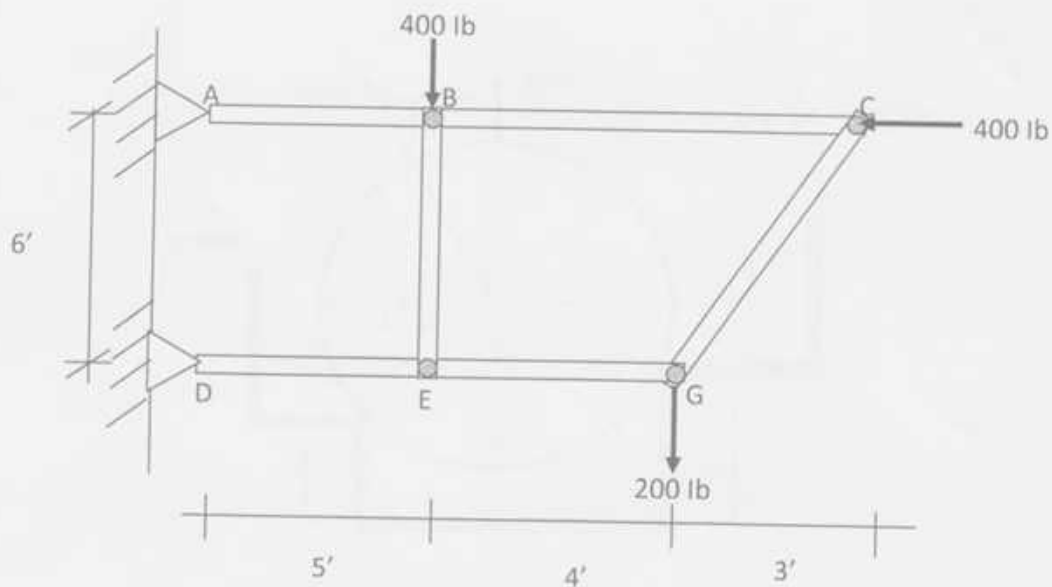

Figure 4

University of Asia Pacific
 Department of Civil Engineering
 Mid-Term Examination, Fall 2014

Course Code: CE 101 (B)
 Course Title: Engineering Mechanics I

Time: 1 (one) Hour
 Full Marks: (3x10) = 30

*Answer all questions.
 Each question carries equal marks*

1. A block with section 1' x 4' and height of 20' weighs 9000 lb. A 2000 lb horizontal force acts 8' from base as shown below. What will be the resultant and its direction? Do you think the block will overturn?

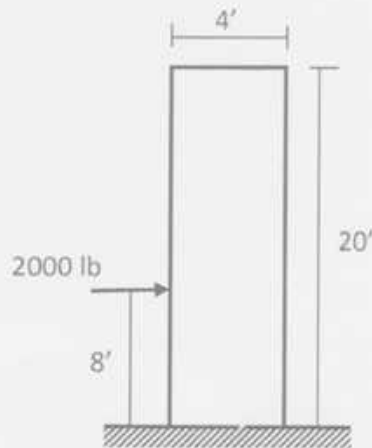

2. Two smooth spheres, each of radius 100 mm and weighing 100 N, rest in a horizontal channel having vertical walls, the distance between which is 360 mm. Find the reactions at the points of contact of A, B, C & D

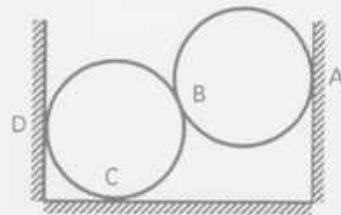

3. In the structure shown below, the weight of sphere G is 10 lb and member ABCD is 20 lb. Calculate the force in EB and the reactions at D. Also draw the free-body diagram of ABCD.

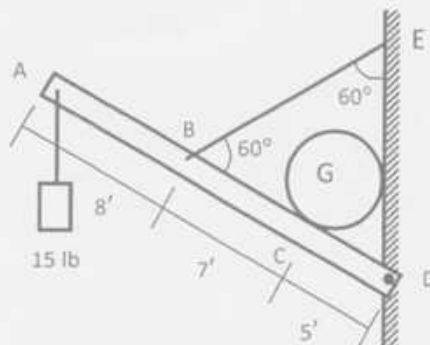

University of Asia Pacific
 Department of Civil Engineering
 Mid Semester Examination Fall 2014
 Program: B.Sc. Engineering (Civil)

Course Title : Engineering Mechanics II
 Time : 3 hours

Course Code: CE 103
 Full Marks: 10X3=30

(Answer all the questions)

1. Determine the minimum load W which will cause motion of the body A to impend up the plane.

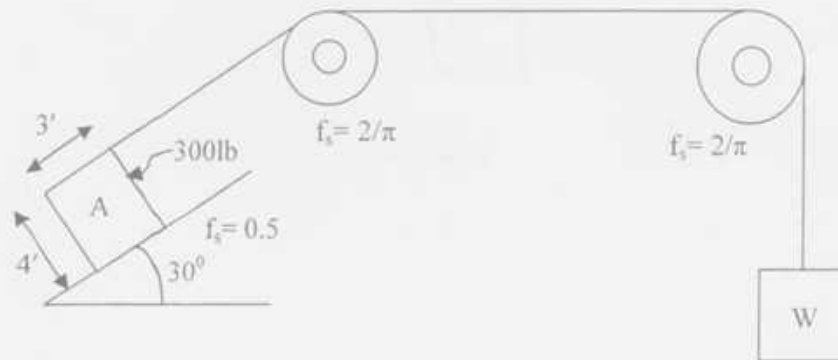

Figure 1

2. The wood handle of the mallet has a unit weight of 55 lb/ft^3 . The head is a homogenous steel cylinder of diameter 6 inch. Find the mass moment of inertia of the mallet with respect to X and Z axis.

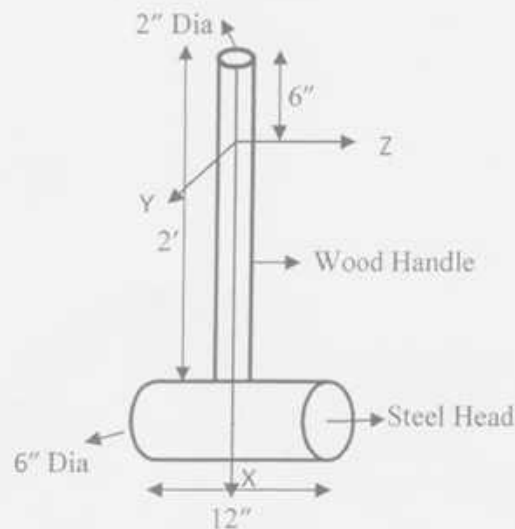

Figure 2

3. Determine the force in each cable used to support the 50 lb crate shown in Figure 3.

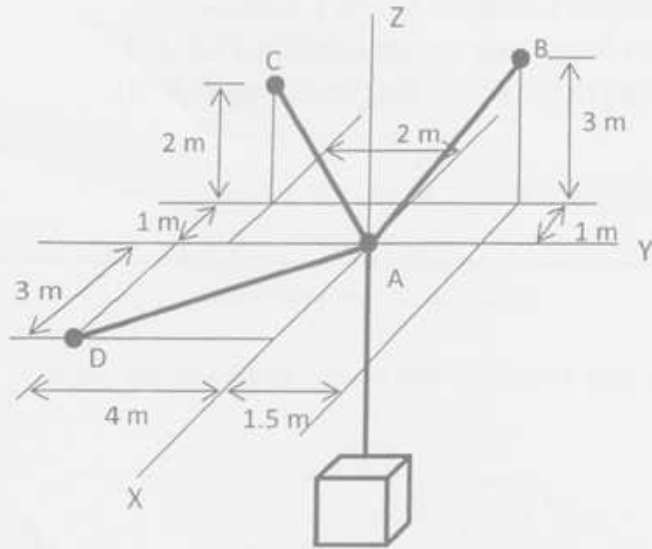

Figure 3

University of Asia Pacific
Department of Civil Engineering
Mid term Examination Fall 2014
Program : B.Sc Engineering (Civil)

Course Title: Engineering Mechanics II
 Time: 1 hour

Course Code: CE103
 Full Marks: (10*3=30)

Answer all the questions

1. What force P must be applied to the wedges shown in the following figure to start them under the block. Frictional coefficient is 0.84 (angle of Friction 40°) for all contact surfaces

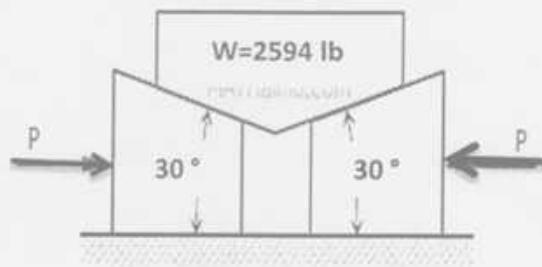

2. In the following Figure, $W_A = 350$ lb, $W_B = 200$ lb, $f_A = 0.25$ and $f_B = 0.33$. How far and in what direction does A travel from rest during 45 sec? What is the tension in the cable C? in the cable D?

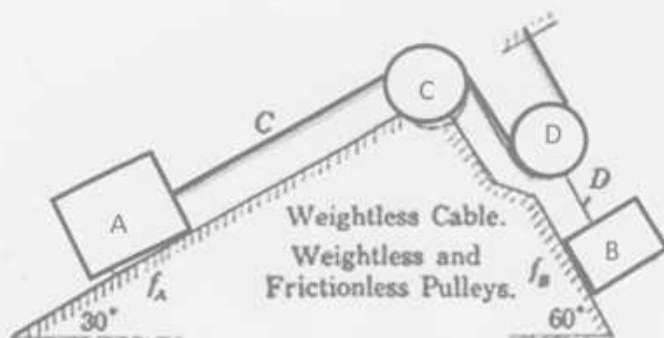

3. If the thin plate has a density of 9684 kg/m³ and a thickness of 25mm, determine its moment of inertia about an axis directed perpendicular to the page and passing through point O
 Outer Plate radius, $R_1 = 350$ mm and inner hole radius, $R_2 = 200$ mm

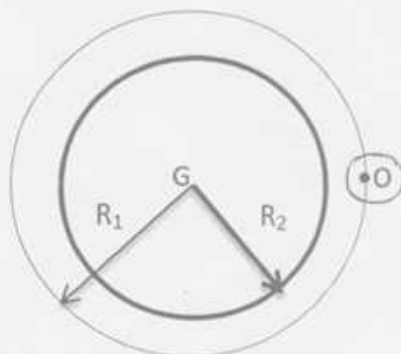

University of Asia Pacific
Department of Civil Engineering
Mid-Term Examination Fall 2014
Program: B.Sc. Engineering (Civil)

Course Title: Surveying (A)
 Time: 1 hour

Course Code: CE 105
 Full Marks: 60

There are four questions. Answer any three.

1. (a) Differentiate between (05)
 - i. Horizontal line and Level Line
 - ii. Bench Mark and Datum
- (b) Briefly explain Barometric Levelling. (05)
- (c) The following notes refer to reciprocal levels taken with a level (10)

Instrument At	Staff readings on		Remarks
	P	Q	
P	2.824	1.748	Distance PQ=2050 m
Q	1.928	1.006	RL of P=125.000

Find the angular error in the collimation adjustment of the instrument.
 Also find the elevation of Q.

2. (a) How can you run a parallel to a chain line through a given point? (05)
- (b) Briefly explain reciprocal ranging. (05)
- (c) Explain suitability and principle of chain surveying. (05)
- (d) A base line BC is measured by a faulty Gunter's chain. Measured length of BC is 2500 ft. Actual length of BC was 2475 ft. find the correction of the chain. (05)
3. (a) Explain how you can measure distance by chain survey between two points on opposite side of a (10)
 - i. River
 - ii. Building
- (b) Find the elevation of points A,B,D,E,F by any method. (10)

station	B.S	I.S	F.S	R.L
A	1.025			
B		2.25		
C		1.580		551.050
D	2.230		1.965	
E	1.355		1.835	
F			1.760	

4. (a) Describe the checks in open traverse. What is the difference between chain survey and traverse survey? (05)
- (b) What is closing error? (02)
- (c) A line has true bearing of $N25^{\circ}W$ and magnetic bearing of $N 35^{\circ} W$. Find the declination angle of the line. (05)
- (d) A closed traverse was conducted and following observations were made. (08)
Work out the missing quantities.

Side	Length(m)	Bearing(W.C.B)
AB	600	$208^{\circ}30'$
BC	?	100°
CD	550	$48^{\circ}30'$
DE	?	$300^{\circ}0'$
EA	450	$150^{\circ}10'$

University of Asia Pacific
Department of Civil Engineering
Mid Semester Examination Fall 2014

Course #: CE 105
Full Marks: 60

(B)

Surveying
Time: 1 hr.

There are four questions. Answer any three of them.

1. a) What is reconnaissance survey? Explain it with a practical example. (3)
b) What do you mean by desktop survey? Write down some features of project survey. (7)
2. a) What is the definition of surveying? Give some example of modern survey tools. (2+2)
b) How satellite distance is measured. Write down the application of GPS, DGPS and RTK (3+3)
3. a) Write down the instruments of plane table survey. (2)
b) What are the advantages of plane table survey? (3)
c) The following offset were taken from a chain line to an irregular boundary line at an interval of 10 m: 0, 2.5, 3.5, 5, 4.6, 3.2, 0. Compute the area between the chain line, the irregular boundary line and the end of offset by:
1. Trapezoidal rule 2. Simpson's rule. (5)
4. a) The width of the formation level of certain cutting 10 m and the side slope is 1:1. The surface of the ground is has a uniform slope of 1 in 6 in the transverse direction. Find the cross sectional area when the depth of cutting at the center is 3 m. (4)
b) An excavation is to be made for a reservoir 40 m long and 30 m wide at the bottom. The side slope of the excavation has to be 2:1. calculate the volume of earthwork if the depth of excavation is 5 m. Assume level ground at the site. (6)

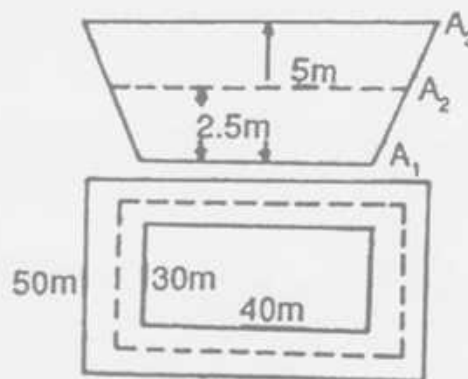

(Hints)

The University of Asia Pacific
Department of Civil Engineering
Midterm Examination Fall 2014

Course # : CE-107

Course Title: Introduction to Civil & Environmental Engineering

Full Marks: 45 (15 X 3 = 45)

Time: 1 hour

Answer any **three (3)** questions of your choice out of the following **four (4)**

- 1a)** Define civil engineering according to ASCE (American Society for Civil Engineers). Mention few names of infrastructures that civil engineers are involved in developing. 3+2=5
- 1b)** What are the major sub-disciplines of civil engineering? Mention the names of some other sub-disciplines that are always inevitably participatory in any civil engineering project. 1.5+1.5=3
- 1c)** Discuss, in brief, "civil engineering" as a career. 5
- 1d)** Give the names in details of the following codes with their related fields. 2
 (i). BNBC (ii). ASTM (iii). ACI (iv). AASHTO
- 2a)** Mention few simple points related to the understanding of science, engineering and technology. 7.5
- 2b)** Mention some (at least six) very important roles of civil engineers in the development of infrastructure. 6
- 2c)** What are the major foci of any civil engineering project. 1.5
- 3a)** Categorize building/construction material based on specific property of material. What are the major factors for choice of materials? 3+2=5
- 3b)** Mention (names only) few types of loads to be considered in design. 2
- 3c)** Categorize building based on type of occupancy. 3
- 3d)** Mention (names only) major components of a building. 5
- 4)** Initially, a five-storied residential building is to be constructed. The building will be vertically extended in the future up to seven storey; so the foundation is to be constructed accordingly. Estimate the total initial construction cost (for now) as per the following particulars and specifications of the building. Use PWD schedule and other relevant information provided in the attached appendix. 15

Sl No	Particulars	Specifications
01	Land Size	65 ft x 100 ft
02	Building Type	Residential (Superior)
03	Allowable Bearing Capacity (q_u)	3.5 ksf
04	Floor Level (s)	5 + 2
05	Plinth Area	52 % of Land Size
06	Construction Material	20 MPa, RCC Structure 1:1.5:3 (Brick Chips)
07	Ground Floor	30% Habitation; 70% Car Parking
08	Roof top RCC water tank including beams and supports etc	2500 Gallons
09	Structure type	RCC Frame Structure
10	For mosaic work in all rooms including stair, tiles in bathrooms and normal finishing	Tk. 950 per sqm
11	Underground water reservoir, distribution line, water pump, pump house, WASA charge	8000 gallons
12	Boundary wall	RCC frame
13	Incidental Cost	Consider 7% for this building

**APPENDIX
PWD SCHEDULE**

1. Foundation Cost upto PL

Storey	q _a = 2 ksf	q _a = 2.50 ksf	q _a = 3.0 ksf	q _a = 3.5 ksf	q _a = 4.0 ksf	q _a = 4.5 ksf	q _a = 5.0 ksf
1	3982	3875	3811	3769	3740	3718	3702
2	4684	4381	4199	4080	3997	3936	3830
3	5591	5036	4702	4482	4329	4217	4133
4	6566	5811	5296	4958	4723	4551	4421
5	8001	6774	6035	5550	5212	4965	4778
6	9495	7851	6862	6213	5759	5429	5178
7	10961	8908	7673	6862	6296	5883	5571
8		10043	8544	7560	6873	6371	5992
9		11252	9471	8302	7487	6891	6441
10		12529	10451	9088	8136	7441	6915

2. Superstructure Cost

		Building Category											
		Non-Residential (fc=19-21 MPa, Brick Chips)			Residential (fc=19-21 MPa, Brick Chips)			Non-Residential (fc=22-25 MPa, Stone Chips)			Residential (fc=22-25 MPa, Stone Chips)		
Level	Floor	Economy	Standard	Superior	Economy	Standard	Superior	Economy	Standard	Superior	Economy	Standard	Superior
0	GF Park	5449	5812	6538	5634	6010	6761	5922	6317	7107	6124	6532	7349
0A	Habitation	8545	9601	12674	8837	9929	13106	9020	10135	13378	9631	10792	14274
1	1 st Floor	8242	9360	12224	8523	9576	12640	8699	9776	12903	9289	10409	13767
2	2nd Floor	8365	9399	12407	8651	9720	12830	8830	9921	13096	9568	10565	14180
3	3 rd Floor	8491	9540	12593	8780	9866	13023	8962	10070	13293	9855	10723	14606
4	4 th Floor	8618	9683	12782	8912	10014	13218	9097	10221	13492	10151	10884	15044
5	5 th Floor	8748	9829	12974	9046	10154	13416	9233	10374	13694	10455	11046	15495
6	6 th Floor	8835	9927	13104	9136	10265	13550	9326	10478	13831	11030	11158	15960

SOME ADDITIONAL COSTS

3. Boundary Wall: Tk.3500/m
4. External Water Supply: Tk.60.00/gallon
5. Gas Connection: GF: Tk.260/sqm
Other floors: Tk.100/sqm
6. Internal Electrification:
 - (i) Residential Building
 - Economy: Tk.1030 /sqm
 - Standard: Tk.1290 /sqm
 - Superior: Tk.1550 /sqm
 - (ii) Non-Residential Building:
 - Economy: Tk.775 /sqm
 - Standard: Tk.970 /sqm
 - Superior: Tk.1160/sqm
7. Internal Sanitary and Water Supply:
 - (i) Residential Building
 - Economy: Tk. 475 /sqm
 - Standard: Tk.715 /sqm
 - Superior: Tk. 1070 /sqm
 - (ii) Non-Residential Building
 - Economy: Tk.360 /sqm
 - Standard: Tk.540 /sqm
 - Superior: Tk.800 /sqm
8. Floor Finish Work: Tk.1000.00/ sqm
9. Roof top RCC water Tank: Tk.85.00/gallon

University of Asia Pacific
Department of Civil Engineering
Mid Semester Examination Fall 2014

Course No: CE 201
Course Title: Engineering Materials

Time: 1 Hour
Full Marks: 60

Answer any **THREE** questions (3 x 20=60) including Question No. 1.
Question No. 1 is compulsory.

1. The Sieve analysis data of a sand sample for a building construction project are summarized below: (20)

ASTM Sieve	Amount Retained (g)
3 inch	0
1.5 inch	0
¾ inch	0
3/8 inch	0
#4	0
#8	50
#12	30
#16	100
#30	80
#40	100
#50	40
#100	10
#200	45
Pan	45

- (i) Calculate the FM of the sand sample,
- (ii) Draw the grading curve for the sand sample,
- (iii) Make a brief discussion on the FM, sieve analysis data, and grading curve,
- (iv) What measures are necessary to improve the grading of the sand sample?

[Sieve opening: #12- 1.7 mm, #40-0.425 mm, #200- 0.075 mm]

2. (a) Discuss the reasons for formation of efflorescence on brick surface. (3)
- (b) Write short note on the following: (6)
- (i) Creep
 - (ii) Relaxation
 - (iii) malleability
- (c) Draw stress-strain curve for the following materials: (4)
- (i) Concrete
 - (ii) Steel
 - (iii) Rubber
 - (iv) Glass

(d) Explain different possible moisture condition of aggregates. (3)

(e) Distinguish between clamp burning and kiln burning of clay bricks. (4)

3. (a) What type of cement commonly used in Bangladesh? Write down their composition according to BDS EN-197. (6)

(b) Explain the cement production process. (5)

(c) What is hydration of cement? Explain the hydration reactions of silicates and aluminates of cements. (6)

(d) Explain the purpose of using gypsum in cement. (3)

4. Mixture proportion of mortar is necessary for plastering work of a brick wall of 30 ft long and 5 ft height. The following data are provided: (20)

Sand to cement ratio (weight basis) = 2.5,

W/C = 0.45,

Specific gravity of cement = 2.9,

Specific gravity of sand = 2.55,

Air content = 2%,

Mortar thickness = 0.50 in (on one side of the wall).

- (i) Calculate the unit contents of sand, cement, and water,
- (ii) Calculate the unit weight of mortar,
- (iii) Estimate the amount of each ingredient (in weight and volume) of mortar necessary for the plastering work of the both surface of the wall. Assume 15% extra volume of material is necessary due to the loss of mortar during application on the wall. Unit weight of cement (with void) = 1400 kg/m^3 and unit weight of sand (with void) = 1600 kg/m^3 .
- (iv) What adjustment in sand volume is necessary, if bulking of sand is 15%?

University of Asia Pacific
Department of Civil Engineering
Midterm Examination Fall 2014

Course # : CE-203
 Full Marks: 40 (10 X 4 = 40)

Course Title: Engineering Geology & Geomorphology
 Time: 1 hour Credit: 3 hours

Answer any four (4) questions of your choice out of the following five (5)

- 1a) Giving two examples of each type of rock, draw the schematic diagram of rock cycle. 4
- 1b) Classify principal zones of earth and write short note of any one. 3
- 1c) Distinguish between sediments and sedimentary rocks. 3
- 2a) Mention (no description required) geomorphic processes based on their origin. Distinguish between weathering and erosion. 3+2=5
- 2b) Define runoff. Distinguish between surface runoff and sub-surface runoff (show sketches also). 1+4=5
- 3) For the following basin, x is a constant factor. Analyze for three basins where values of x are 0.5, 1 and 2, respectively and identify the one that would exhibit maximum runoff. Justify your answer. Also calculate the FF and CC of the basin. 10

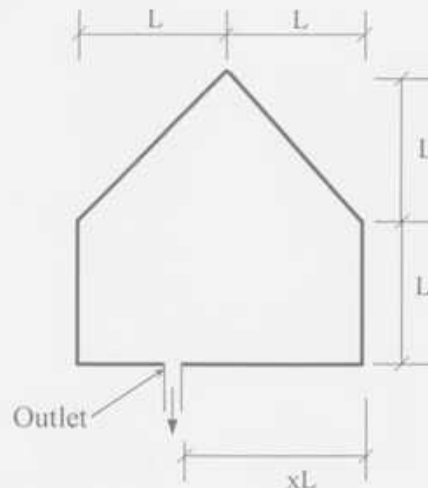

- 4a) Define diastrophism. Draw a neat sketch of typical fold geometry. 1.5+2.5=4
- 4b) Sketch and mention few major features of any three types of drainage pattern. 6
5. (d) Calculate the peak runoff (Q_p) in m^3/s for the restaurant complex as shown in the figure in the next page. Use the following data/information as necessary. 10
- Rainfall Intensity for the whole area = 1.05 in/hr
 - The area is symmetric about y direction.

Area Type	Co-efficient of Runoff
Concrete	0.8
Asphalt	0.75
Grass	0.25

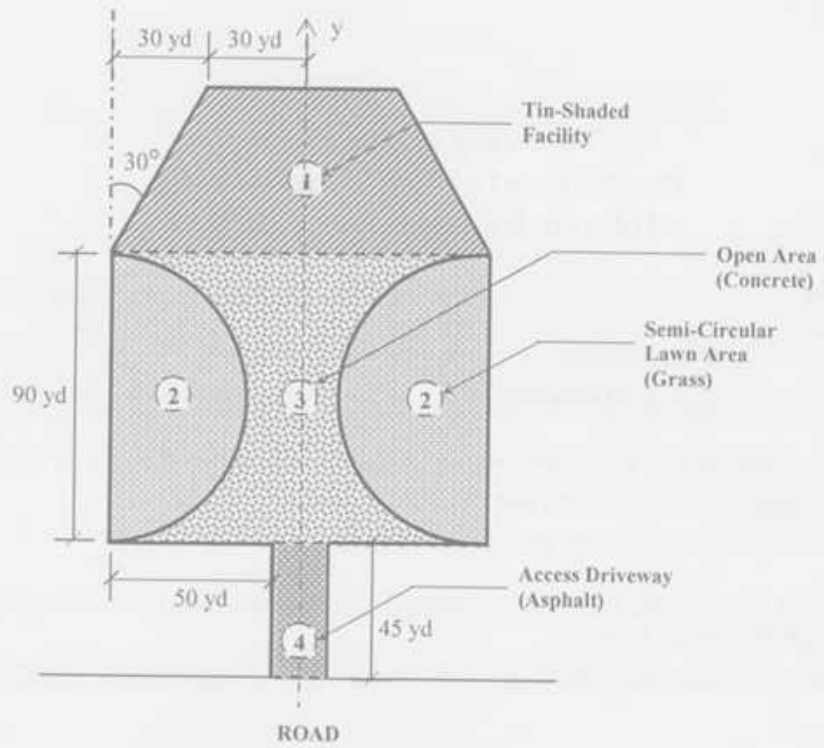

University of Asia Pacific
Department of Civil Engineering
Mid Semester Examination Fall 2014

Course #: CE 205
Full Marks: 20

Numerical Analysis and Computer Programming
Time: 1 hr

1. Using Regula-Falsi method determine the root of the following equation which lies between 1 and 1.5

$$x \cos\left(\frac{x}{x-2}\right) = 0 \quad ; \quad \text{take } \varepsilon = 0.0001 \quad [05]$$

2. Use Gauss Jordan method to solve the following system of linear equation. [05]

1. $-2x + 7y + 2z = 5$
2. $x + 2y - 5z = -1$
3. $6x - 2y + z = 13$

3. Find the root of the equation $x^3 + 3x - 5 = 0$ by Bisection method. Where [1, 2] and $\varepsilon = 0.001$. [05]

4. Fit the curve $Y = aX + b/X$ to the following data and determine Y_9 . [05]

DATA	
X	Y
1	5.43
2	6.28
3	8.23
4	10.32
5	12.63
6	14.86
7	17.27
8	19.51
9	

2-2

University of Asia Pacific
Department of Civil Engineering
Mid-Term Examination Fall 2014
Program: B.Sc. Engineering (Civil)

Course Title: Fluid mechanics

Course Code: CE 221

Time: 1 hour

Full Marks: 60

There are three questions. Answer all.

1. (a) Define viscosity and compressibility of fluid. (03)
(b) Classify fluid flow on the basis the criteria of "space" and "Time". (04)
(c) Define "stream function" and "Potential function". (04)
(d) A fluid having kinematic viscosity of 0.08 stoke is filled between two parallel plates. Plates are at a distance of 6m. Lower plate is at rest and upper plate is moving. Velocity distribution is expressed as $V=98-3*(6-y)^2$, where V is in cm/s and y is distance from lower plate in m. what is the velocity of upper plate? Also calculate the velocity gradient and shear stress at upper plate. (09)
2. (a) In a flow the velocity vector is given by $V = -4xi + 9yj - 2zk$. (10)
Determine the equation of the streamline. Streamline passes through a point A(3.5, -2, 6).
(b) Absolute pressure at A is 150 kN/m²[figure 2(b)]. Find the gauge pressure at B by using the Manometer readings. (10)
3. (a) Determine the resultant force acting on the circular curved surface ABC (08)
shown in figure 3(a). ABC is a quadrant of the circle which diameter is 15m. Distance from point "O" to water surface is 3m.
(b) Draw the hydrostatic pressure variation on the inclined surface AB shown (12)
in figure 3(b). Also find the value and location of total hydrostatic force on that inclined Surface.

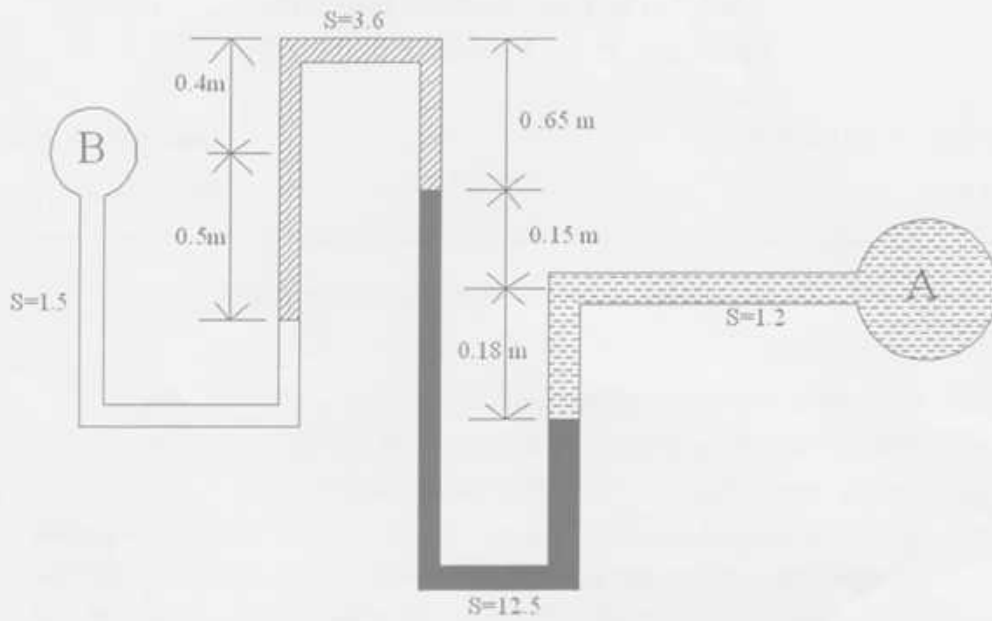

Figure 2(b)

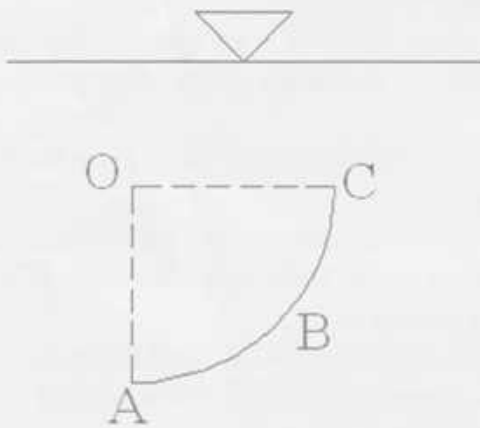

Figure 3(a)

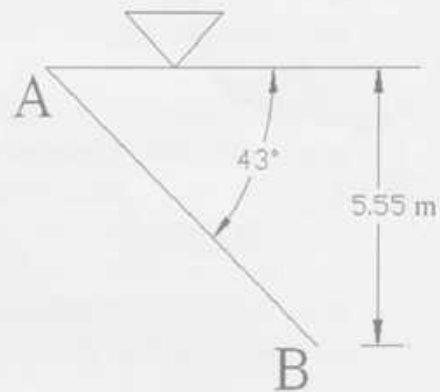

Figure 3(b)

University of Asia Pacific
Department of Civil Engineering
Mid-Term Examination Fall 2014

Course Code: CE 211 (A & B)
Course Title: Mechanics of Solids I

Time: 1 (one) Hour
Full Marks: (3x20) = 60

*Answer all questions.
Each question carries equal marks*

1. Draw Shear Force and Bending Moment Diagram for the following beam loading.

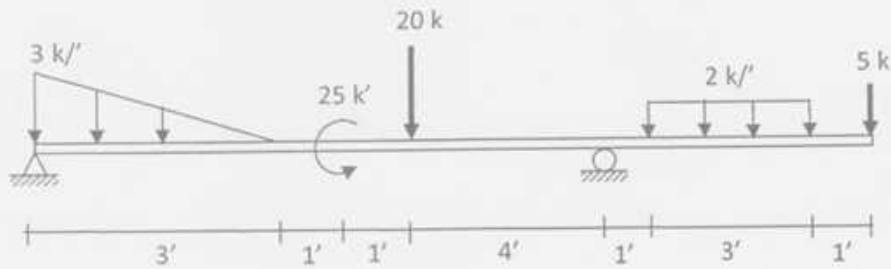

2. Determine the functions for loading, shear and bending moment for the following beam.

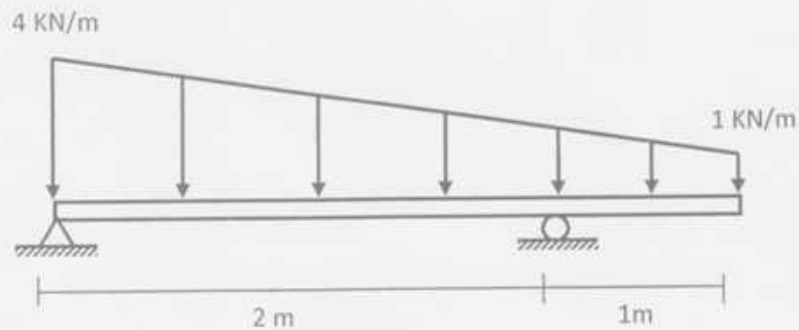

3. Use singularity function to draw SFD and BMD of the beam shown below.

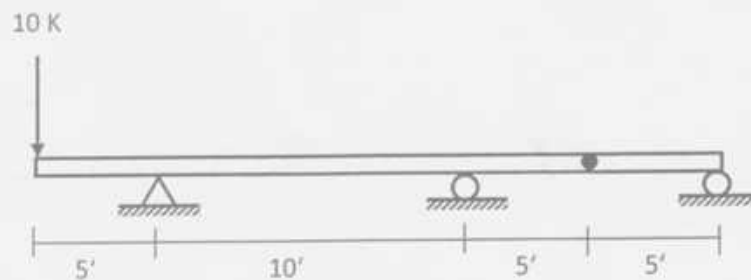

University of Asia Pacific
Department of Civil Engineering
Mid Semester Examination Fall 2014 (Set 1)

Course #: CE 213
 Full Marks: 40 (= 4 × 10)

Course Title: Mechanics of Solids II
 Time: 1 hour

1. Fig. 1 shows a Mohr's circle of stress, whose radius is 20 kPa. The line oa is a tangent at point a of the Mohr's circle. Calculate the
- Principal stresses (σ_1, σ_2) and maximum shear stress $\tau_{xy(max)}$ for the circle.
 - Normal stress σ_{xx} and shear stress τ_{xy} at the point a .

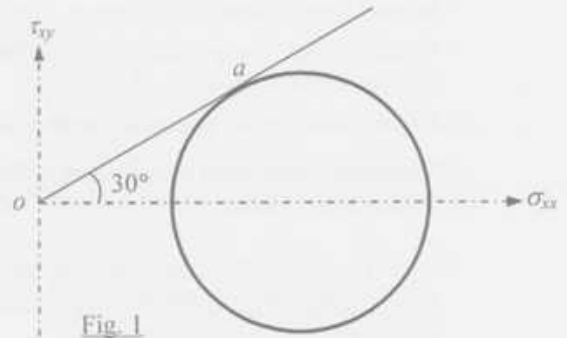

2. The slab $ABCDE$ weighs 20 k and also carries a live load of 10 k as shown in Fig. 2. Calculate the
- Vertical reaction in spring D
 - Maximum torsional shear stress and vertical deflection of spring D
- [Given (for spring): Shear modulus = 12000 ksi, coil diameter = 0.5", inside diameter of spring = 3", number of coils = 5].

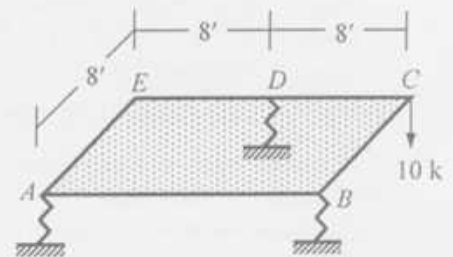

Fig. 2

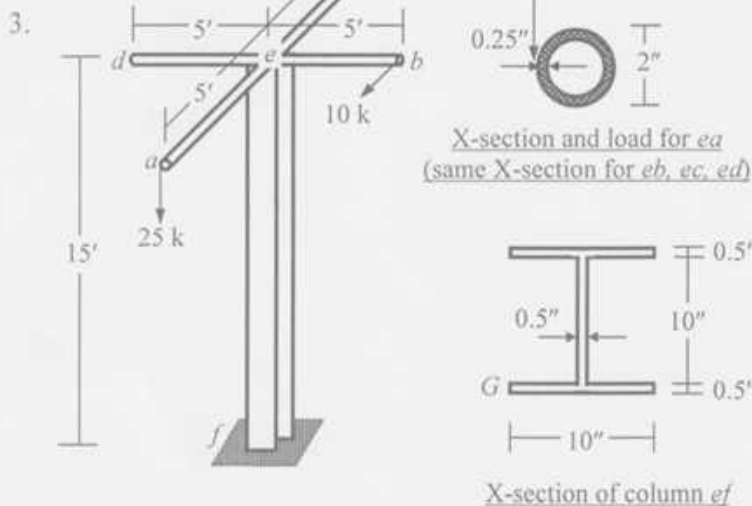

Fig. 3

Beams ea, eb, ec, ed are loaded as shown in Fig. 3 and supported on column ef , which is fixed at f .

- Calculate the maximum torsional stress and maximum torsional rotation for
- Beam ea ,
 - Column ef .

4. For the structure $abcdef$ loaded as shown in Fig. 3, calculate the
- Normal stress and shear stress at point G of the section f of column ef ,
 - Principal stress (σ_1) and corresponding angle (θ_1) of principal plane at point G .

List of Useful Formulae for CE 213

* Torsional Rotation $\phi_B - \phi_A = \int (T/J_{eq}G) dx$, and $= (TL/J_{eq}G)$, if T , J_{eq} and G are constants

Section	Torsional Shear Stress	J_{eq}
Solid Circular	$\tau = Tc/J$	$\pi d^4/32$
Thin-walled	$\tau = T/(2A)t$	$4A^2/(ds/t)$
Rectangular	$\tau = T/(\alpha bt^2)$	βbt^3

b/t	1.0	1.5	2.0	3.0	6.0	10.0	α
α	0.208	0.231	0.246	0.267	0.299	0.312	0.333
β	0.141	0.196	0.229	0.263	0.299	0.312	0.333

- * Normal Stress (along x-axis) due to Biaxial Bending (about y- and z-axis): $\sigma_x(y, z) = M_z y/I_z + M_y z/I_y$
- * Normal Stress (along x-axis) due to Combined Axial Force (along x-axis) and Biaxial Bending (about y- and z-axis): $\sigma_x(y, z) = P/A + M_z y/I_z + M_y z/I_y$
- * Corner points of the kern of a Rectangular Area are $(b/6, 0)$, $(0, h/6)$, $(-b/6, 0)$, $(0, -h/6)$
- * Maximum shear stress on a Helical spring: $\tau_{max} = \tau_{direct} + \tau_{torsion} = P/A + Tr/J = P/A (1 + 2R/r)$
- * Stiffness of a Helical spring is $k = Gd^4/(64R^3N)$
- * $\sigma_{xx}' = (\sigma_{xx} + \sigma_{yy})/2 + \{(\sigma_{xx} - \sigma_{yy})/2\} \cos 2\theta + (\tau_{xy}) \sin 2\theta = (\sigma_{xx} + \sigma_{yy})/2 + \sqrt{\{(\sigma_{xx} - \sigma_{yy})/2\}^2 + (\tau_{xy})^2} \cos (2\theta - \alpha)$
 $\tau_{xy}' = -\{(\sigma_{xx} - \sigma_{yy})/2\} \sin 2\theta + (\tau_{xy}) \cos 2\theta = -\sqrt{\{(\sigma_{xx} - \sigma_{yy})/2\}^2 + (\tau_{xy})^2} \sin (2\theta - \alpha)$
 where $\tan \alpha = 2 \tau_{xy}/(\sigma_{xx} - \sigma_{yy})$
- * $\sigma_{xx(max)} = (\sigma_{xx} + \sigma_{yy})/2 + \sqrt{\{(\sigma_{xx} - \sigma_{yy})/2\}^2 + (\tau_{xy})^2}$; when $\theta = \alpha/2, \alpha/2 + 180^\circ$
 $\sigma_{xx(min)} = (\sigma_{xx} + \sigma_{yy})/2 - \sqrt{\{(\sigma_{xx} - \sigma_{yy})/2\}^2 + (\tau_{xy})^2}$; when $\theta = \alpha/2 \pm 90^\circ$
- * $\tau_{xy(max)} = \sqrt{\{(\sigma_{xx} - \sigma_{yy})/2\}^2 + (\tau_{xy})^2}$; when $\theta = \alpha/2 - 45^\circ, \alpha/2 + 135^\circ$
 $\tau_{xy(min)} = -\sqrt{\{(\sigma_{xx} - \sigma_{yy})/2\}^2 + (\tau_{xy})^2}$; when $\theta = \alpha/2 + 45^\circ, \alpha/2 - 135^\circ$
- * Mohr's Circle: Center $(a, 0) = [(\sigma_{xx} + \sigma_{yy})/2, 0]$ and Radius $R = \sqrt{\{(\sigma_{xx} - \sigma_{yy})/2\}^2 + (\tau_{xy})^2}$
- * Maximum Normal Stress Theory (Rankine): $|\sigma_1| \geq Y$, or $|\sigma_2| \geq Y$
- * Maximum Normal Strain Theory (St. Venant): $|\sigma_1 - \nu\sigma_2| \geq Y$, or $|\sigma_2 - \nu\sigma_1| \geq Y$
- * Maximum Shear Stress Theory (Tresca): $|\sigma_1 - \sigma_2| \geq Y$, $|\sigma_1| \geq Y$, or $|\sigma_2| \geq Y$
- * Maximum Distortion-Energy Theory (Von Mises): $\sigma_1^2 + \sigma_2^2 - \sigma_1\sigma_2 = Y^2$

University of Asia Pacific
Department of Civil Engineering
Mid Term Examination Fall 2014
Program: B.Sc. Engineering (Civil)

Course Title: Structural Engineering I
 Time: 1 hr

Course Code: CE 311
 Full Marks: 4X10=40

1. Draw the shear force and bending moment diagrams of the following structure.

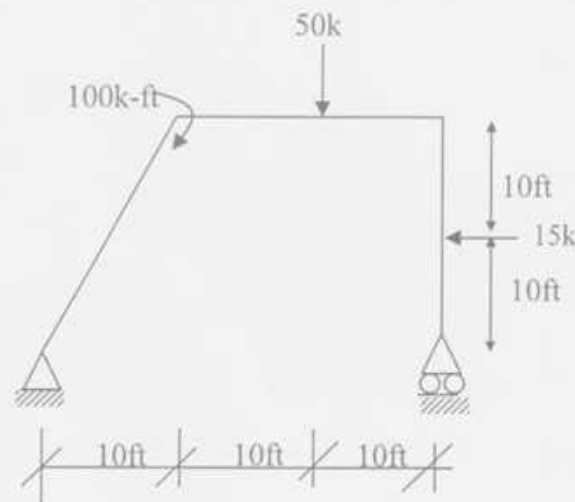

2. Draw influence lines for (i) Bending moment at E, (ii) Reaction at A, (iii) Shear just left of support B and (iv) Shear just right of support B of the beam shown in figure below.

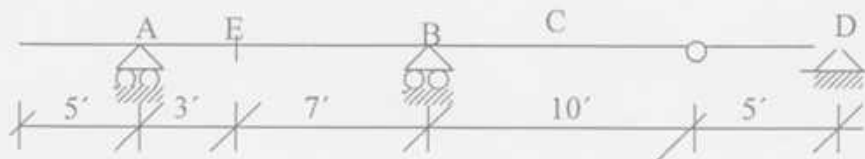

3. Girder AB supports a floor system as shown in the figure below. Draw the Influence line for (i) floor beam reaction at panel point "3", (ii) support reaction at "A", (iii) shear in panel 2-3 and (iv) bending moment for girder at panel point "2".



4. Draw influence line diagrams for bar forces of A, B and C for the truss shown in the figure below. Unit load moves from X to Y.

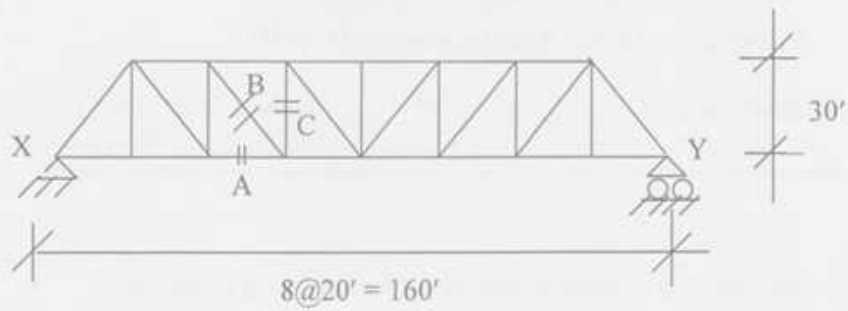

University of Asia Pacific
Department of Civil Engineering
Mid Term Examination Fall 2014
Program: B.Sc. Engineering (Civil)

Course Title: Structural Engineering II
 Time: 1 hr

Course Code: CE 313
 Full Marks: 3x20=60

1. Calculate all member forces of the statically indeterminate truss shown below assuming that full panel shear will be equally divided by the diagonals both in tension and compression.

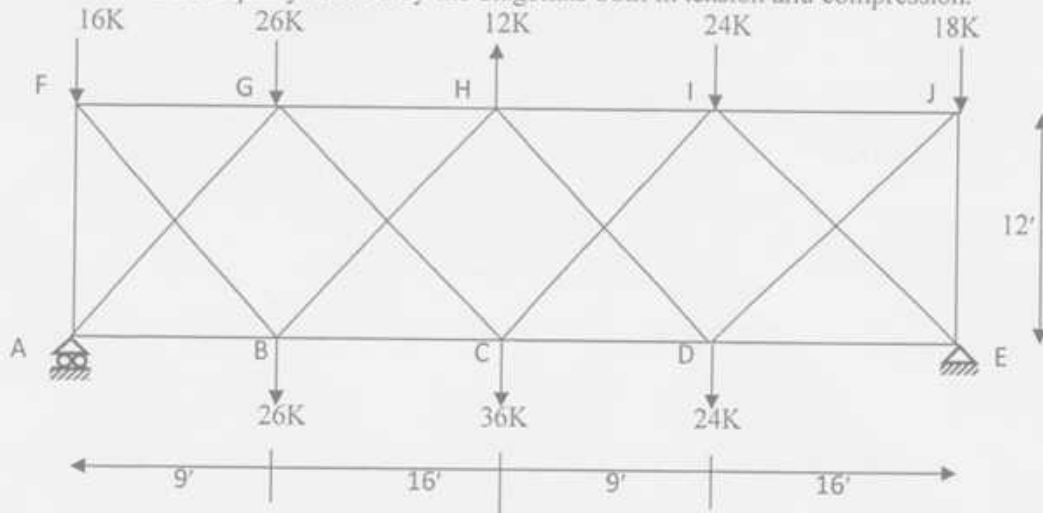

2. For the structure shown below, use the Cantilever Method to draw the AFD of the columns, SFD and BMD of the beams. Column areas are given beside the columns.

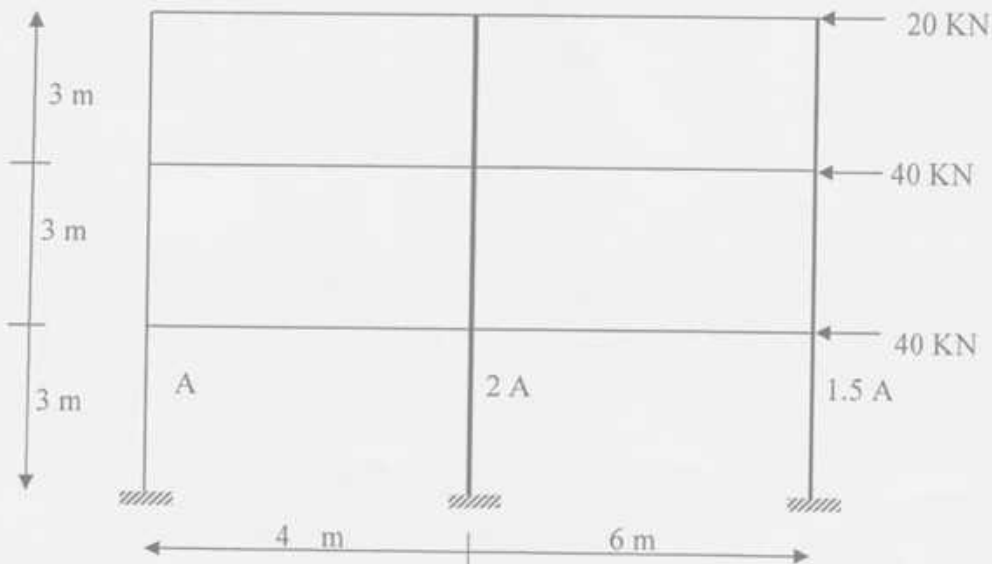

3. Calculate the slope at point A of the beam shown below using virtual work method [Given $E = 3,000 \text{ ksi}$, $I_1 = 1,000 \text{ in}^4$, $I_2 = 4,000 \text{ in}^4$].



University of Asia Pacific
Department of Civil Engineering
Mid Term Examination Fall 2014
Program: B.Sc. Engineering (Civil)

Course Title: Structural Engineering II
 Time: 1 hour

Course Code: CE 313
 Full Marks: 4x10=40

[Answer all the questions]

1. For the 2-storied frame loaded as shown in Fig. 1, (a) Use the Portal Method to determine the value of P if shear at column ef is 16.5 k (leftward), (b) Use the Cantilever Method to draw the axial force diagram of the column abc when $P = 18$ k.

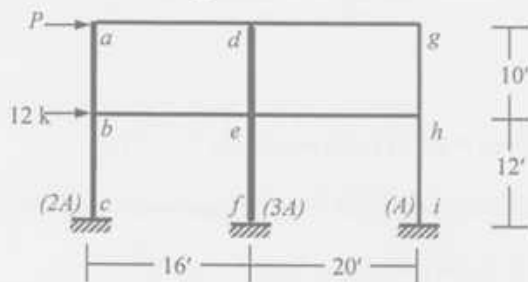

Fig. 1

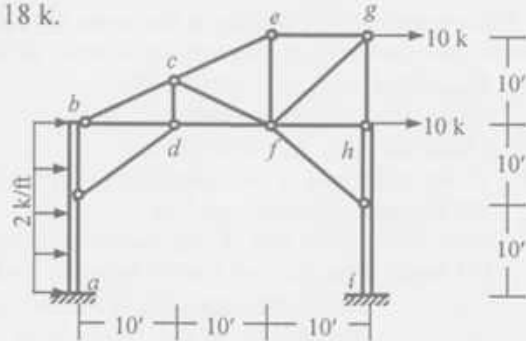

Fig. 2

2. In the mill bent shown in Fig. 2, use the Portal Method to draw the bending moment diagram of the column ab .
3. Calculate the rotation at joint d of the beam shown in Fig. 3 using Virtual Work Method [Given: $EI_{ab} = EI_{cd} = 20 \times 10^3 \text{ k-ft}^2$, $EI_{bc} = 40 \times 10^3 \text{ k-ft}^2$].



Fig. 3

4. For the truss shown in Fig. 4, use the Virtual Work Method to determine the vertical deflection of joint f for the applied load [Given: $EA/L = 500 \text{ kip/ft}$, for all the truss members].

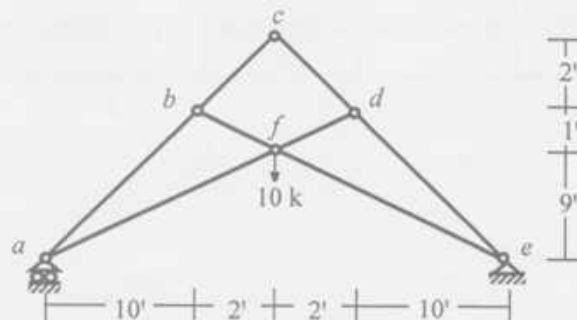

Fig. 4

List of Useful Formulae for CE 313

*Portal Method for multi-storied frames assumes

- The shear force in an interior column is twice the shear force in an exterior column.
- There is a point of inflection at the center of each column, and at the center of each beam.

* Cantilever Method is based on three assumptions

- The axial force in each column of a story is proportional to its horizontal distance from the center of gravity of all the columns of the story.
- There is a point of inflection at the center of each column, and at the center of each beam.

*Vertical Analysis based on approximate location of hinges

$$M_{(+)} = 0.08 wL^2, M_{(-)} = 0.045 wL^2,$$

$$V_{(+)} = wL/2, \text{ and } V_{(-)} = -wL/2$$

*Vertical Analysis using ACI Coefficients

$$M_{(+)} \text{ (i) For end spans, if discontinuous end is (a) unrestrained } = wL^2/11, \text{ (b) restrained } = wL^2/14$$

$$\text{(ii) For interior spans } = wL^2/16$$

$$M_{(-)} \text{ (i) At the exterior face of first interior supports for (a) Two spans } = wL^2/9, \text{ (b) More spans } = wL^2/10$$

$$\text{(ii) At the other faces of interior supports } = wL^2/11$$

$$\text{(iii) For spans not exceeding } 10', \text{ of where columns are much stiffer than beams } = wL^2/12$$

$$\text{(iv) At the interior faces of exterior supports, if the support is (a) a beam } = wL^2/24, \text{ (b) a column } = wL^2/16$$









$$V \text{ (i) In end members at first interior support } = \pm 1.15wL/2, \text{ (ii) At all other supports } = \pm wL/2$$

*Deflection of truss due to load, temperature change and misfit, $\Delta = \sum N_i dL = \sum N_i (N_0 L / EA + \alpha \Delta T L + \Delta L)$

*Deflection of beams/frames due to axial, shear and flexural deformation,

$$\Delta = \int (x_1 x_0 / EA) dS + \int (v_1 v_0 / GA^*) dS + \int (m_1 m_0 / EI) dS$$

Integration of Product of Functions ($I = \int f_1 f_2 dS$)

$f_2 \backslash f_1$					
	AaL	$BaL/2$	$AaL/2$	$(A+B)aL/2$	$[A+4C+B]aL/6$
	$AbL/2$	$BbL/3$	$AbL/6$	$[A+2B]bL/6$	$[2C+B]bL/6$
	$AaL/2$	$BaL/6$	$AaL/3$	$[2A+B]aL/6$	$[A+2C]aL/6$
	$A(a+b)L/2$	$B(a+2b)L/6$	$A(2a+b)L/6$	$[A(2a+b)+B(a+2b)]L/6$	$[Aa+Bb+2C(a+b)]L/6$

University of Asia Pacific
Department of Civil Engineering
Mid Term Examination Fall 2014
Program: B.Sc. Engineering (Civil)

Course Title: Design of Concrete Structures I
 Time: 1 hr

Course Code: CE 315
 Full Marks: 2x15=30

[Answer all the questions]

1.a) What are load and resistance factors? Why they are used in USD? (5)

b) Use the USD to design the cantilever beam AB as singly reinforced beam ($b = 15''$), loaded as shown in the figure below (in addition to its self-weight), if working dead load $w_D = 1$ k/ft, and working live load $w_L = 1.2$ k/ft, assuming a steel ratio of ρ_{max} . (10)

Take Load factor 1.4 for Dead load and 1.7 for live load

[Given: for Cantilever, $M_u = wL^2/2$; $M_n = M_u/0.9$; $f_c' = 4$ ksi, $f_y = 60$ ksi, $\alpha = 0.72$,

$$\rho_b = (\alpha f_c' / f_y) \{ 87 / (87 + f_y) \}, \rho_{max} = 0.75 \rho_b$$

$$M_n = \rho f_y (1 - 0.59 \rho f_y / f_c') b d^2$$

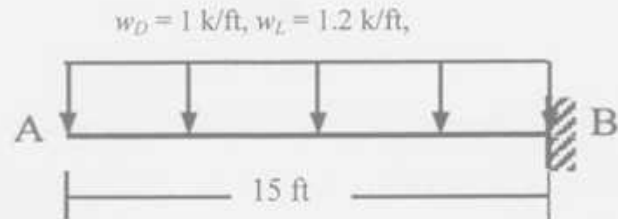

2.a) What is the Working Stress Design of Reinforced Concrete? Mention the main features of WSD. (5)

b) Use the WSD Method to design the simply supported singly reinforced RC beams shown below, **neglecting their self-weights** and assuming (10)

(i) $L = 15'$ [Given: $f_c' = 3.5$ ksi, $f_{call} = 1.58$ ksi, $f_{sall} = 30$ ksi, $n=10$, $k= 0.344$, $j= 0.885$, assume $b=12$ inch]

(ii) $L = 27'$ [Given: $f_c' = 4.5$ ksi, $f_{call} = 1.80$ ksi, $f_{sall} = 24$ ksi $n=9$, $k= 0.4$, $j= 0.865$, assume $b=15$ inch]

Use Formula $A_s = M_{max} / (f_{sall} j d)$; $M_{max} = 0.5 f_{call} k j b d^2$

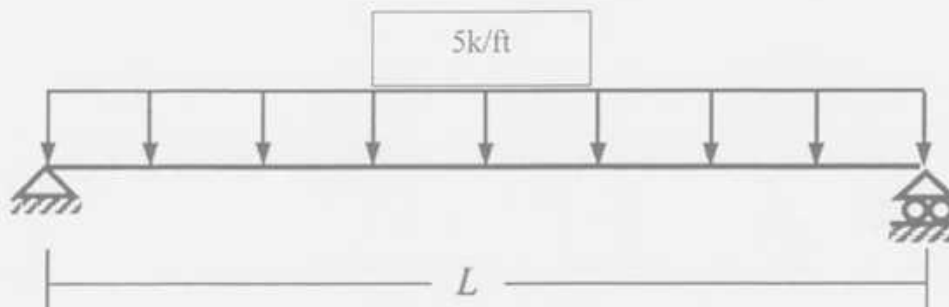

University of Asia Pacific
Department of Civil Engineering
Mid Term Examination Fall 2014
Program : B.Sc Engineering (Civil)

Course Title: Design of Concrete Structure I
Time : 1 hr

Course Code : CE 315 (3-1 (A))
Full Marks : 30

(There are 4 questions. Answer all of them)

1. Calculate the uniformly distributed load (including beam self-weight) which will cause the section (Fig 1) to begin to crack if it is used for 28 ft simple span. Given, $f'_c = 4$ ksi and $f_y = 60$ ksi. Use, $f_r = 7.5 \sqrt{f'_c}$ (7)

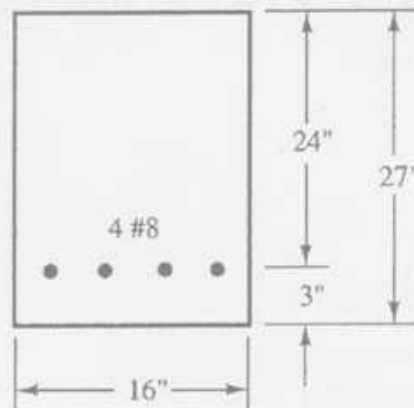

Fig 1

2. A rectangular beam (Fig 2) is to be designed using $f'_c = 4$ ksi and $f_y = 60$ ksi. This beam experiences a uniformly distributed DL of 3 k/ft (including beam self-wt.) and a concentrated 15 kip LL. Use, $b = 14$ " and #10 bar. (15)

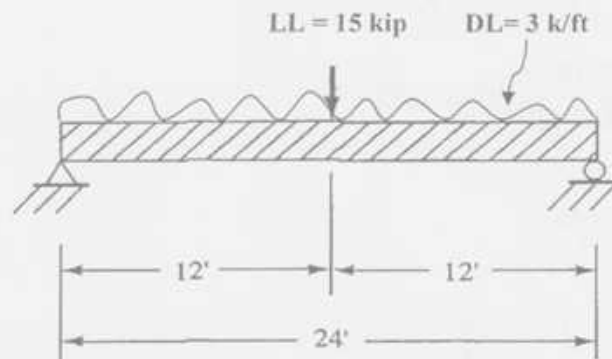

Fig 2

3. Determine the location of the N.A. (i.e. in web or flange) of the T-shaped beam in middle (Fig 3). Given, A_s = Area of 3-#9 bars, $F_c = 4$ ksi, $f_y = 60$ ksi and Beam span = 18 ft. (5)

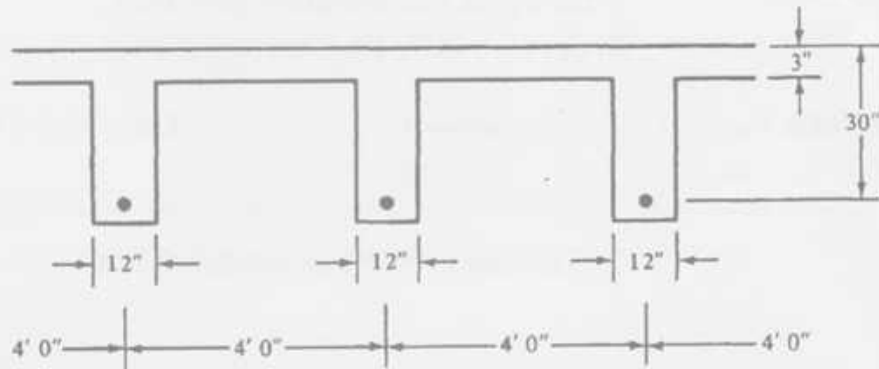

Fig 3

4. Write the purpose of ϕ factor and Load factor. Why load factor is greater for live load than dead load? (3)

Formula's Given:

$$\phi M_n = M_u = \phi A_s f_y d \left(1 - \frac{1}{1.7} \frac{\rho f_y}{f'_c} \right)$$

$$\rho = \frac{0.85 f'_c}{f_y} \left(1 - \sqrt{1 - \frac{2R_n}{0.85 f'_c}} \right)$$

$$\phi = 0.65 + (\epsilon_t - 0.002) \left(\frac{250}{3} \right)$$

$$R_n = \frac{M_u}{\phi b d^2} = \rho f_y \left(1 - \frac{1}{1.7} \frac{\rho f_y}{f'_c} \right)$$

$$\beta_1 = 0.85 - \left(\frac{f'_c - 4000}{1000} \right) (0.05) \geq 0.65$$

$$a = \frac{A_s f_y}{0.85 f'_c b} = \beta_1 c$$

$$\phi M_n = \phi A_s f_y \left(d - \frac{a}{2} \right)$$

University of Asia Pacific
Department of Civil Engineering
Mid Term Examination Fall 2014
Program: B.Sc. Engineering (Civil)

Course Title: Design of Concrete Structures II
 Time: 1 hr

Course Code: CE 317 (A-section)
 Full Marks: 3x15=45

[Answer all the questions]

1. a) Discuss the significance of the limitation laid by ACI for long span/short span should be less than 2 for two-way slab design. (5)
- b) Use WSD to design the following slab system shown in Fig. 1, supported by 12"x12" beam all around and 12"x12" column. Calculate the required reinforcements [Given, FF = 35 psf, PW = 45 psf, LL = 90 psf, $f'_c = 3$ ksi and $f_y = 60$ ksi, $f_s = 24$ ksi, $n = 9$, $k = 0.378$, $j = 0.874$]. (10)

$$\begin{array}{lll}
 +C_{A(DL)} = 0.027, & +C_{A(LL)} = 0.032, & -C_A = 0.071 \\
 +C_{B(DL)} = 0.033, & +C_{B(LL)} = 0.035, & -C_B = 0.00
 \end{array}$$

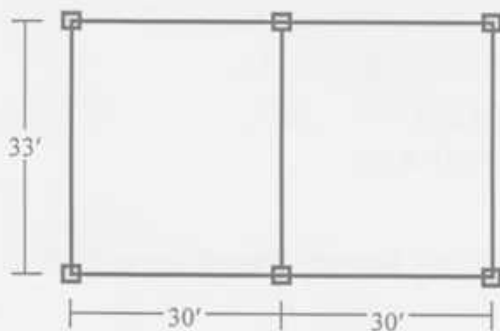

Fig. 1

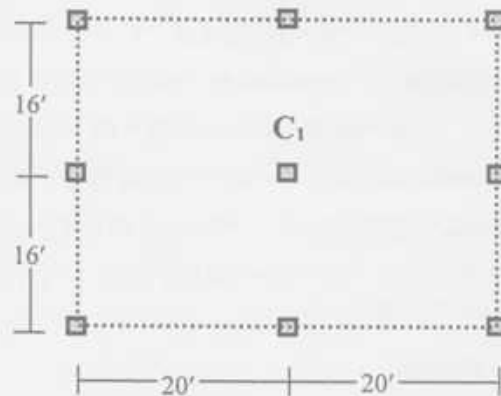

Fig. 2

2. A building is to be designed as a flat plate structure. A plan of the building is shown in Fig 2 and dimension of all columns is 12"x12". Using WSD, check column C_1 of the slab shown in Fig. 2 for punching shear and calculate shear reinforcements [Given, slab thickness = 6 inch, FF = 25 ksf, RW = 20 ksf, LL = 40 ksf, $f'_c = 3$ ksi and $f_y = 40$ ksi, $f_{c,all} = 1.35$ ksi and $f_{s,all} = 18$ ksi] (15)
3. a) Mention and justify the maximum and minimum steel ratios specified by ACI for RC columns. Explain why transverse reinforcements are used in RC columns. (5)
- b) Using USD method design a tied column for a DL = 600^k and LL = 300^k. [Given: $f'_c = 4$ ksi and $f_y = 60$ ksi and $f_{s,all} = 20$ ksi and steel ratio is 2.5%] (10)

List of Useful Formulae for CE 317

Two way Slab

$$* -M_A = C_A \times W_T \times A^2, \quad * -M_B = C_B \times W_T \times B^2$$

$$* +M_A = C_{A(DL)} \times W_{DL} \times A^2 + C_{A(LL)} \times W_{LL} \times A^2, \quad * +M_B = C_{B(DL)} \times W_{DL} \times B^2 + C_{B(LL)} \times W_{LL} \times B^2 \quad * A_s = M/f_s j d$$

Column-Supported Slabs

* Total Static Moment at Factored Loads, $M_0 = w_n L_2 L_n^2 / 8$

* Total static moment for interior spans: $M_u^{(-)} = 0.65 M_0, M_u^{(+)} = 0.35 M_0$

* Distribution Factors applied to Static Moment M_0 for Positive and Negative Moments

Position of Moment	Ext Edge unrestrained (a)	Slab with beams between all supports (b)	No beam between interior supports		Exterior Edge fully restrained (e)
			Without edge beam (c)	With edge beam (d)	
Exterior $M^{(-)}$	0.00	0.16	0.26	0.30	0.65
Interior $M^{(-)}$	0.75	0.70	0.70	0.70	0.65
$M^{(+)}$	0.63	0.57	0.52	0.50	0.36

$$* \alpha = E_{cb} I_b / E_{cs} I_s \quad * \beta_r = E_{cb} C / 2 E_{cs} I_s \quad * C = \sum (1 - 0.63 x/y) x^2 y / 3$$

% of Exterior $M^{(-)}$ supported by Column Strip = $100 - 10\beta_r + 12\beta_r (\alpha_1 L_2/L_1) (1 - L_2/L_1)$

% of $M^{(+)}$ supported by Column Strip = $60 + 30 (\alpha_1 L_2/L_1) (1.5 - L_2/L_1)$

% of Interior $M^{(-)}$ supported by Column Strip = $75 + 30 (\alpha_1 L_2/L_1) (1 - L_2/L_1)$

$$* A_v = (V_n - V_c) / (f_y \sin \alpha) \quad * S = A_s f_y d / (V - V_c)$$

$$* V_c = 4 \sqrt{f'_c} b_o d \quad * V_c = (2 + 4/\beta_c) \sqrt{f'_c} b_o d \quad * V_c = (2 + \alpha_s d/b_o) \sqrt{f'_c} b_o d \quad [\text{Use half of the values for WSD}]$$

$$* V_c = 1.1 \sqrt{f'_c} b_o d$$

Short Column

$$* P_n = 0.85 f'_c A_c + f_y A_s = A_g [0.85 f'_c + \rho_s (f_y - 0.85 f'_c)]$$

$$* P_u = \alpha \phi A_g [0.85 f'_c + \rho_s (f_y - 0.85 f'_c)]$$

$$* P_{all} = \phi' (0.25 f'_c A_g + f_{sall} A_s) = \phi' A_g (0.25 f'_c + \rho_s f_{sall})$$

$$* \rho_s = 0.45 (A_g / A_{core} - 1) (f'_c / f_y) \quad * S = 4 A_{sp} / (\rho_s d_{core})$$

University of Asia Pacific
Department of Civil Engineering
Mid Semester Examination Fall 2014
Program: B.Sc. Engineering (Civil)

Course Title: Environmental Engineering I
Time- 1 hour

Course Code: CE 331
Full marks: 50

There are **THREE** questions. Answer any **TWO**. (2 X 25 = 50)

1. (a) Show that the ground water yield of an unconfined aquifer , can be expressed as ,
 $Q = \frac{\pi k (D^2 - d^2)}{\log_e (R/r)}$ (7)

(b) A 100 mm diameter tubewell is sunk 35 m below static groundwater level. The depth of water in the tubewell while pumping is 33m. The radius of drawdown is 30 m and the coefficient of permeability of the aquifer is 0.5 l/s/m². Calculate the probable discharge of the well. (8)

(c) Define porosity, specific yield and specific retention and also show the relationship among them. An aquifer with a porosity of 30% and specific yield of 20% has 1000 m³ in volume and can store 350 m³ of water. Determine the specific retention for the aquifer (%) and also calculate how much volume of water can be yielded by gravity drainage. (6+4)

2. (a) Write down the problems of groundwater development in Bangladesh. Also discuss briefly how the present situation in Bangladesh for freshwater scarcity can be minimized? (7)

(b) Write short notes on (i) Shallow shrouded tubewell, (ii) Infiltration Galleries, (c) Salt water intrusion in coastal areas (8)

(c) What are the challenges/problems of developing rainwater harvesting system? (3)

(d) Calculate the per capita water available and the capacity of the storage tank required for a family of 8 persons having a roof area of 17 m² with a runoff coefficient of 0.7. The family lives in a part of Bangladesh having a yearly rainfall of 2.5 m. The distribution demands 35% storage requirement for full utilization of rainwater. (7)

3. (a) Compare (characteristics) between (i) Corrosive water and scale forming water (ii) Branched network and looped network (8)

(b) What is water hammer and how can it be prevented? (6)

(c) What are the common problems in water conveyance systems? (3)

(d) Below is given the rain water availability mass curve which assumes that the cumulative consumption/demand at a constant rate is equal to total available rainwater. From the figure, estimate the

capacity of storage tank for full utilization of the rainwater and therefore determine the fraction (f) of the total available rainfall that is stored. (8)

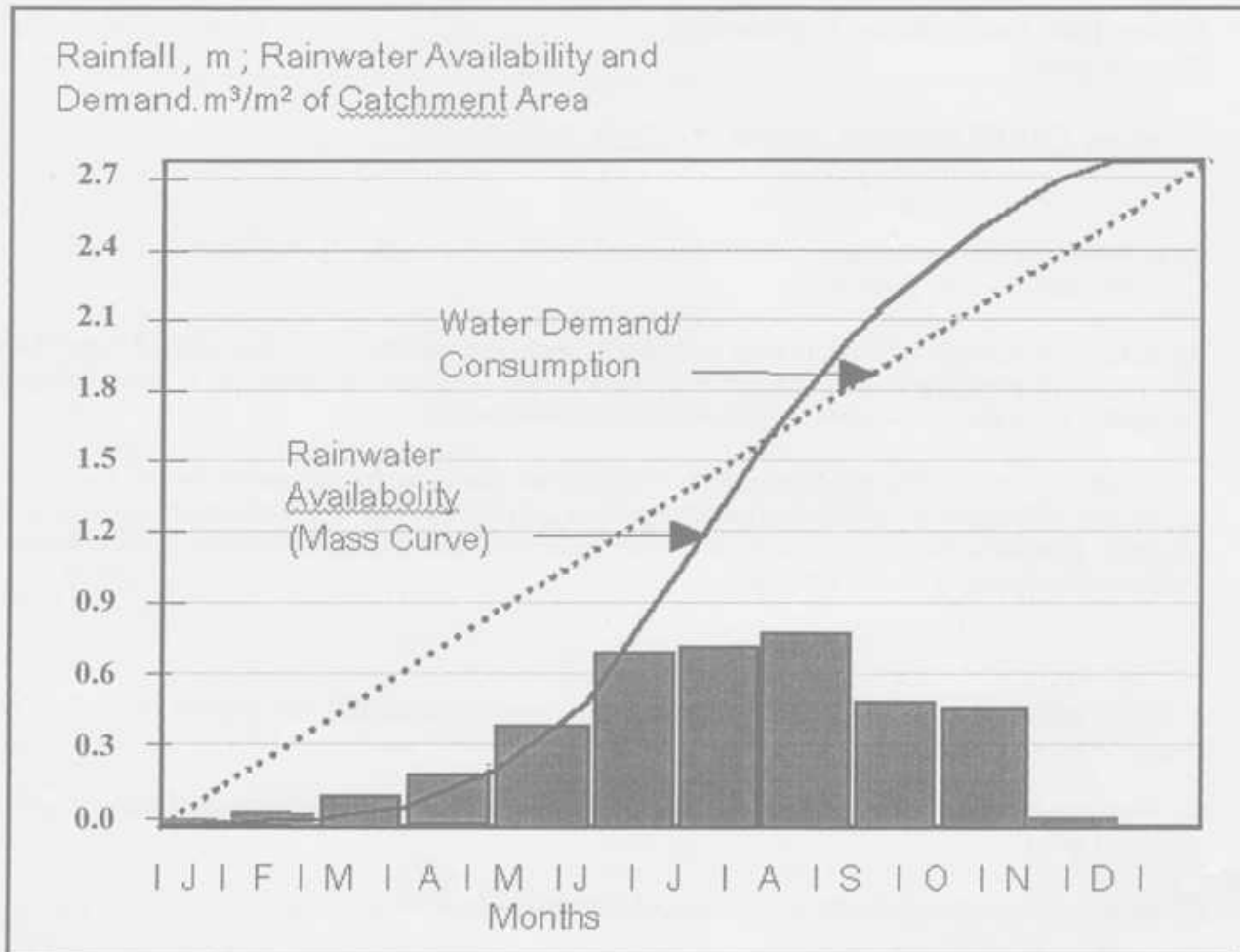

Figure: Rainfall intensity, cumulative rainwater availability and demand

3-2

University of Asia Pacific
Department of Civil Engineering
Mid Semester Examination Fall 2014
Program: B.Sc. Engineering (Civil)

Course Title: Environmental Engineering II
Time- 1 hour

Course Code: CE 333
Full marks: 60

Answer all of the questions below

Assume reasonable value for any missing data (if applicable)

1. (a) Write the advantages and disadvantages of VIP latrines. (6)
- (b) Design leach pits for both single and alternating twin off-set pit pour-flush latrines serving a family of eight members living in a sub-urban area. Wastewater flow is 25 lpcd and the soil is sandy loam. $[A_i = Q / I, V_i = Q D/4I, V_s = C \times P \times N]$ (14)
2. (a) What are the technical advantages of small bore sewerage system over the conventional sewerage system? (5)
- (b) Estimate the maximum daily design flow from a composite area with the given land use pattern and condition as follows: (15)
 - (i) an residential area of 5 hectares, occupied by 200 people/ha having an average waste water generation rate of 80 lpcd. Consider the infiltration rate to be 150 lpd per meter over the sewer length of 15 m, including the house connections.
 - (ii) a 5 hectare buissness district employing 300 people and generating 100 liter per capita of waste water per day.Time of concentration for the composit area is 25 minutes and the runoff coefficient can be taken as 0.75. The rainfall curve is given by: $I \text{ (cm/hr)} = 101.6 / (t + 20)$.
3. (a) Define – (i) Self cleansing velocity (ii) Time of concentration (8)
(iii) On-site sanitation system (iv) Off-site sanitation system
- (b) Using the Nomogram, given in Fig. 1, determine the required sewer pipe diameter for discharging the maximum domestic sewage flow, generated by 1500 people having an average water supply of 100 lpcd. The pipe is to be laid on the slope of 0.003 and the Manning's coefficient is to be considered as 0.013. Also estimate the allowable discharge and flow velocity in the sewer flowing 1/3 th of full depth, where the ratio for discharge and velocity are 0.18 and 0.77 respectively. (12)

Table 1: Design Values for Long-term Infiltration Rates for Wastewater into Various Soils

Soil Type	Long term infiltration rate, I (l/m ² -day)
Sand	50
Sandy loam	30
Porous loam, porous silty clay loam	20
Compact silty loam, clay	10

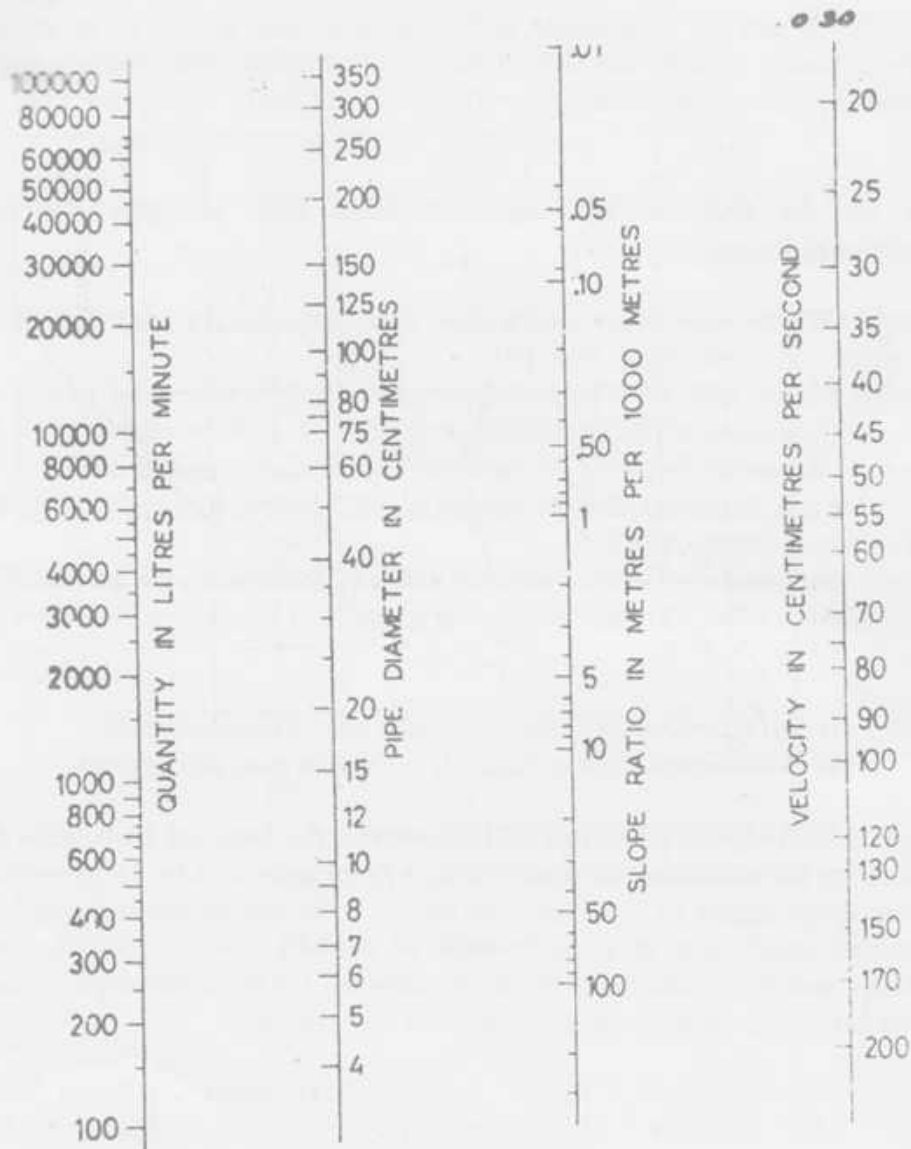

Fig 1: Nomogram based on Manning's formula for circular pipes (for n = 0.013) running full

University of Asia Pacific
 Department of Civil Engineering
 MidTerm Examination
 Fall 2014
 Program: B.Sc. Engineering (Civil)

Course Title: Geotechnical Engineering I
 Time: 1 hour

Course Code: CE 341
 Full Marks: 20

There are 5 questions. Answer any 4.

(4x5=20 marks)

- 1.(a) Classify the following soil. The properties of the subgrade soil are found as follows. 4
- Percent finer than 0.075 mm = 10 %
 Percent finer than 0.425 mm = 30 %
 Percent finer than 0.6 mm = 40 %
 Percent finer than 4.75 mm = 60 %
 Liquid limit = 52 %
 Plastic limit = 35 %
- (b) What is the effective size of the above soil? 1
- 2.(a) Derive the relation between dry unit weight, bulk unit weight and water content. 2
- (b) Draw the following (typical) curves using the direct shear test results of loose and dense sands, 2
- (i) axial strain vs shear strain
 (ii) shear stress vs shear strain
- (c) Draw the three phase diagram of saturated soil. 1
- 3.(a) In a CU Triaxial test on normally consolidated clay sample, applied confining pressure was 150 kPa. The sample fails under 300 kPa of deviator stress. Pore water pressure was measured 50 kPa. 4
- (i) Draw the effective stress Mohr circle (with coordinates on x-axis) at **failure** for the above test.
 (ii) Draw the Mohr Coulomb failure envelope (effective stress).
 (iii) Find the angle of internal friction and the angle of the failure plane (with major principal axis).
- (b) Identify the following soils according to the available information mentioned below: 1
- (i) Soil A: Liquid limit = 25%; Plastic limit = 25%
 (ii) Soil B: 70% of the soil particles remain in suspension for 3 days; low specific gravity
- 4.(a) What are the Atterberg limits? Demonstrate (schematically) how these limiting water contents define the four states of soil. 2
- (b) What are the shear strength parameters? Show their relations in τ vs σ plot for both the cohesionless and cohesive soil. 2
- (c) Draw a flow net below a sheet pile wall (impervious layer is 18 m below the ground surface) and mention the following for the flownet: 2
- (i) No of flow line
 (ii) No of flow channel
 (iii) No of potential drops
5. Calculate total stress, effective stress and pore water pressure at the top and the middle of the saturated clay layer. (Figure 1). 5

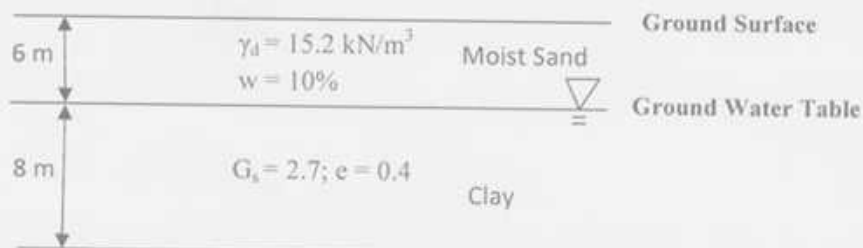

Figure 1

University of Asia Pacific
Department of Civil Engineering
Midterm Examination
Fall 2014
Program: B.Sc Engineering (Civil)

Course Title: Transportation Engineering I
 Full Marks: 20

Course Code: CE 351
 Time: 1hour

There are **Three** questions. Answer two of them

1. a) The following data were observed for 6 vehicles traversing 5 mile segment of a highway. 6
 Calculate the Time Mean Speed and the Space Mean Speed of the vehicles.

Vehicle	Time (min)
1	5.7
2	4.8
3	4.6
4	5.9
5	6.3
6	6.2

- b) Compare on-street and off-street parking. 4

2. a) Design a two-phase signal of a cross-junction for the data given below: 8

Amber 3 sec
 Red-amber 2 sec

	N-S	E-W
Inter green	8	7
Lost time	2	3

	Approaches			
	North	South	East	West
Flow, veh/hr	820	790	810	770
Saturation flow veh/hr	2310	2170	2440	2510

Draw the phase diagram.

- b) Briefly describe mandatory traffic sign. 2

3. a) What is the objective of origin destination survey? 2

- b) Calculate the AADT for the following data. Data was collected on Monday in March. 8
 MEF for March is 1.635. Necessary Table is provided in the next page.

Hour	Volume
6:00-7:00 a.m.	700
7:00-8:00 a.m.	865
8:00-9:00 a.m.	620
9:00-10:00 a.m.	980
10:00-11:00 a.m.	770

Table for 3b)

Table 1 Hourly Expansion Factors for a Rural Primary Road

Hour	Vol.	HEF	Hour	Vol.	HEF
6:00-7:00 a.m.	294	42.01	6:00-7:00 p.m.	743	16.6
7:00-8:00 a.m.	426	28.99	7:00-8:00 p.m.	706	17.5
8:00-9:00 a.m.	560	22.05	8:00-9:00 p.m.	606	20.4
9:00-10:00 a.m.	657	18.8	9:00-10:00 p.m.	489	25.3
10:00-11:00 a.m.	722	17.11	10:00-11:00 p.m.	396	31.2
11:00-12:00 p.m.	667	18.52	11:00-12:00 a.m.	360	34.3
12:00-1:00 p.m.	660	18.71	12:00-1:00 a.m.	241	51.2
1:00-2:00 p.m.	739	16.71	1:00-2:00 a.m.	150	82.3
2:00-3:00 p.m.	832	14.84	2:00-3:00 a.m.	100	124
3:00-4:00 p.m.	836	14.77	3:00-4:00 a.m.	90	137
4:00-5:00 p.m.	961	12.85	4:00-5:00 a.m.	86	144
5:00-6:00 p.m.	892	13.85	5:00-6:00 a.m.	137	90.2
Total daily volume =		12350			

Table 2 Daily Expansion Factors for a Rural Primary Road

Day of Week	Volume	DEF
Sunday	7,895	9.515
Monday	10,714	7.012
Tuesday	9,722	7.727
Wednesday	11,413	6.582
Thursday	10,714	7.012
Friday	13,125	5.724
Saturday	11,539	6.51
Total weekly volume =		75,122

University of Asia Pacific
Department of Civil Engineering
Mid Semester Examination Fall 2014

Course #: CE 361
Full Marks: 60

Open Channel Flow
Time : 1 hr.

There are three questions. Answer the entire questions.

1. a) What do you mean by steady uniform flow? Distinguish between the Reynolds number and Froude number. (3+3)
- b) A circular channel 2.75 m in diameter carries a discharge of $6.55 \text{ m}^3/\text{s}$ at a depth of 1.1 m. Determine the state of flow of this channel. (14)
2. a) Derive the expression of the pressure distribution of curvilinear flow. (8)
- b) What are the governing equations for steady one dimensional flow? (2)
- c) Using the trapezoidal rule of numerical integration, compute the discharge per unit width, the mean velocity and the numerical values of α and β for the following velocity measurements along a vertical in wide channel, when the total depth is 6 m. (10)

Z (m)	0	1.0	2.0	3.0	4.0	5.0	6.0
U (m/s)	0	2.95	3.31	3.62	3.95	4.12	4.51

3. a) Prove that Hydraulic section for critical flow Computation in a triangular section is 5. (6)
- b) Prove that for a rectangular channel Specific energy is equal to the 1.5 times of critical depth. (4)
- c) For trapezoidal channel with $b=6 \text{ m}$ and $s=2$, compute the critical depth and the velocity if $Q=50 \text{ m}^3/\text{s}$. Take $\alpha=1$ (Trial and Error method) (10)

University of Asia Pacific
Department of Civil Engineering
Mid Term Examination Fall 2014

Course # : CE 363
Full Marks:60

Course Title: Engineering Hydrology
Time: 1 hours

Answer all question

1. Calculate in a one step, the precipitable water in a saturated air column of 2000m high above 1 m^2 of ground surface. The surface pressure is 101.3 kPa, the surface air temperature is 30°C and the lapse rate is $6.5^\circ\text{C}/\text{km}$. (10)
2. Four rain gauges located within a rectangular area with four corners at (0,0), (20,0), (20,20) and (0,20) have the following coordinates and recorded rainfalls: (12)

Raingauge location	Rainfall (cm)
(5,5)	1.5
(15, 5)	2.0
(10, 15)	2.4

3. A catchment area has five rain gauge stations. In a year the annual rainfall recorded by the gauges are as follows:

Station	A	B	C	D	E
Rainfall(cm)	88	104	138	78	56

For a 10% error in the estimation of the mean rainfall, calculate the minimum number of additional stations required to be established in the catchment. (7)
4. Why pan coefficient is introduced to calculate evaporation using different evaporation pan? List the various data that are needed to use Penman's equation for estimating the potential evapotranspiration from a given area. (6+4=10)
5. Explain the Horton's decay of infiltration capacity with time. (6)
6. Distinguish between: (3x3=9)
 - a) Actual and potential evapotranspiration
 - b) Field capacity and permanent wilting point
 - c) Recording and non-recording rain gauges
7. Define the following: (3x2=6)
 - i) Φ - index
 - ii) Sleet and Glaze
 - iii) Energy balance in a water body

University of Asia Pacific
Department of Civil Engineering
Mid Term Examination Fall 2014
Program: B.Sc. Engineering (Civil)

Course Title: Project Planning and Management
Time: 1 hour

Course Code: CE401
Full Marks: 20

1. Construction Management is a complex and challenging discipline – Explain with reasons. (2)
2. Which one is said to be “the fundamental of planning”? What are its advantages? (2)
3. What is meant by planning? Why planning is important? (2)
4. What is a project? What is not a project? Define the characteristics of a project? (2)
5. What is the Gantt Chart? What do you understand from that diagram? What are the drawbacks of that diagram? (3)
6. What are the elements of a legal contract? What do you understand by counter contract? What are the documents that form a contract? (3)
7. Find the total duration and critical path of the following activities. (4)

Activity	Duration (mins)	Predecessor
Make Menu	30	-
Shop for ingredients	60	Make Menu
Prepare ingredients	60	Shop for ingredients
Prepare appetizers	60	Shop for ingredients
Cook food	30	Prepare ingredients
Wash table	45	Make Menu
Set table	15	Wash table
Serve food	0	Set table, Cook food, prepare appetizers

8. Why do we need written contract? (2)

University of Asia Pacific
Department of Civil Engineering
Mid Term Examination Fall 2014
Program: B.Sc. Engineering (Civil)

Course Title: Professional Practices and Communication
Time: 1 Hour

Course Code: CE 403
Full Marks: 20

Answer all questions.

1. What are the most valuable attributes of an Engineer? Explain the ways that cause harm. 4
2. Among the 3 cares of model of responsibility, please explain 'responsible care model of responsibility' of an engineer. 3
3. What are the impediments of responsibility? Explain any 4. 3
4. According to IEEE code of ethics, describe at least 4 ethics of an engineer. 2
5. Read the following case and answer the question from ethical point of view. 3

Tom was named the department manager of a large new chemical processing unit to be designed and constructed. During the course of his work, Tom suggested to the project designer an alteration to the design that considerably improved safety. After Tom's suggestion has been successfully implemented, Tom was offered a very nice fishing trip to South America.

Should Tom accept the fishing trip? Give your explanation.
6. What is meant by communication? What are the factors that affect communication? 2.5
7. What are the effective skills for better communication? Please explain some of it (at least 4). 2.5

University of Asia Pacific
Department of Civil Engineering
Mid Term Examination Fall 2014
Program: B.Sc. Engineering (Civil)

Course Title: Structural engineering V (Prestressed Concrete)
 Time: 1 hr

Course Code: CE 415
 Full Marks: 60

[There are **four** questions and answer any **three** from the following questions. Assume value for any missing data]

1. A pretensioned concrete beam has a section of 250 mm by 450 mm (**Fig: 1**). It is eccentrically prestressed with 520 mm^2 of steel which is anchored to the bulkheads at a unit stress of 1400 MPa. The c.g.s. is 100 mm above the bottom fiber. Assuming $n=7$, using exact method compute the stresses in the concrete immediately after transfer due to the prestress only. (20)

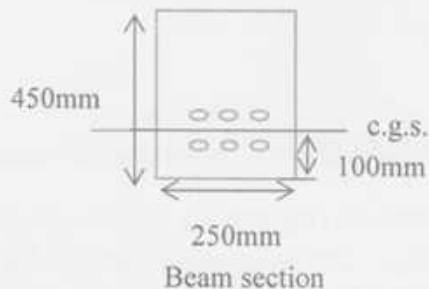

Fig: 1

2. (a) A post-tensioned concrete rectangular beam 400 mm by 450 mm has a simple span of 14 m and it is prestressed with 1050 mm^2 steel which is made up of 5 tendons. The tendons are tensioned one after another to the stress of 1300 MPa. If $E_{ci} = 33000 \text{ MPa}$ and $E_s = 200000 \text{ MPa}$, Compute the loss of prestress due to the elastic shortening of concrete. (13)

(b) What are the basic principles of prestressed concrete? (7)

3. (a) What are the differences between partial prestressing and fully prestressing? (5)

(b) A symmetric I-section is prestressed with 1850 mm^2 steel with an effective stress 1200 MPa. The c.g.s of strands which supply the prestress is 115 mm above the bottom of the beam as shown in **Fig: 2**. Find the ultimate moment capacity of the section for design. (Given: $f_{pu} = 1800 \text{ MPa}$, $f_c = 48 \text{ MPa}$) (15)

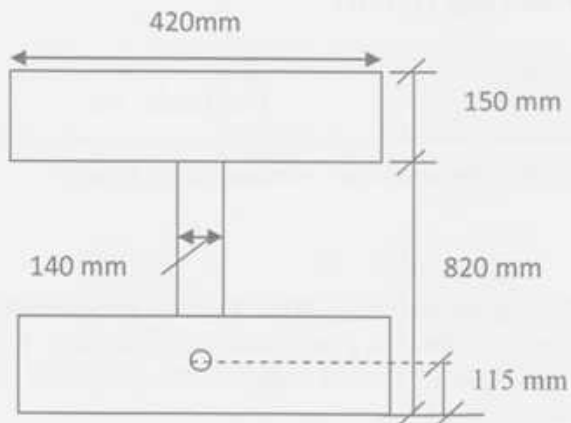

Fig: 2

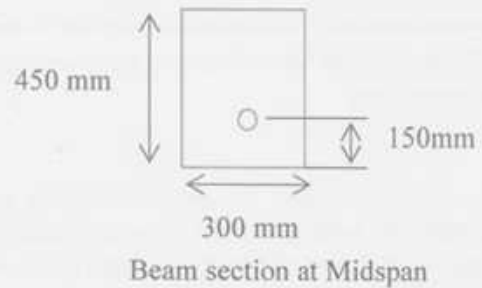

Fig: 3

4. (a) Write short notes on- (a) Prestressed Concrete, (b) Frictional loss of prestressed concrete (6)

(b) A prestressed-concrete rectangular beam 300 mm×450 mm (Fig: 3) has a simple span of 8 m and is loaded by a uniform load of 35 kN/m excluding its own weight. The prestressing tendon is located as shown in the figure and it produces an effective prestress of 2250 KN. Using the Load balancing method find out the fiber stresses at the midspan section. (14)

Required Formulae

- ❖ $f_c = -(F/A) \pm (Fey/I) \pm (My/I)$
- ❖ $f_c = -(F/A) \pm (M_u y/I)$
- ❖ $\Delta f_s = n [-(F/A) \pm (Fe^2/I) \pm (Me/I)]$
- ❖ $\Delta f_s = n f_c$
- ❖ $f_c = -(F/A_c) \pm (Fey/I)$
- ❖ $f_c = -(F/A_g) \pm (Fey/I)$
- ❖ $f_{ps} = f_{pu} \{1 - 0.5 \rho_p (f_{pu}/f'_c)\}$
- ❖ $\rho_p = A_{ps}/bd$
- ❖ $a = (A_{ps} f_{ps} / 0.85 f'_c b)$
- ❖ $w_p = (\rho_p f_{ps} / f'_c) \leq 0.3$
- ❖ $M_u = \phi A_{ps} f_{ps} \{d - (a/2)\}$
- ❖ $A_{pf} = \{0.85 f'_c (b - b_w) h_f\} / f_{ps}$
- ❖ $A_w = A_{ps} - A_{pf}$
- ❖ $\rho_w = (A_w / b_w d)$
- ❖ $w_{pw} = (\rho_w f_{ps} / f'_c) \leq 0.3$
- ❖ $M_u = \phi [A_{pf} f_{ps} \{d - (h_f/2)\} + A_w f_{ps} \{d - (a/2)\}]$
- ❖ $\phi = 0.9$

University of Asia Pacific
Department of Civil Engineering
Mid Semester Examination Fall 2014

Course #: CE 417
 Full Marks: 60

Design of Steel Structure
 Time : 1 hr'

There are three questions. Answer the entire questions.

1. a) Select lightest section of A 36 steel for a column of 20 feet long to carry an axial load of 180 kip. Use ASD method. Assume Fixed-Pinned ends of 20 ft long column in both axes. Probable Column sizes with sectional properties are given below. (14)

Size	A_g (in ²)	r_x (in)	r_y (in)
W 10×39	11.5	4.27	1.98
W 10×45	13.3	4.30	2.01
W 12×40	11.8	5.13	1.93

- B) Draw a column strength curve and indicate regions of short, intermediate and long column. How does failure of short column differ from that of long column? (6)

2. a) Using ASD method, determine the strength of the column having cross section and support condition in the following figure. Use A 572 Grade 50 steel. (12)

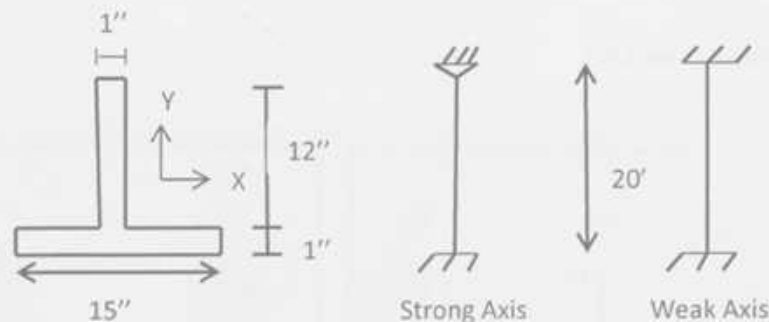

- b) Define effective length factor. Calculate effective length factors for column BC, EF, CD and FG shown in the following figure. Size of columns and beams are given with figure. K factors are provided in table-1 (8)

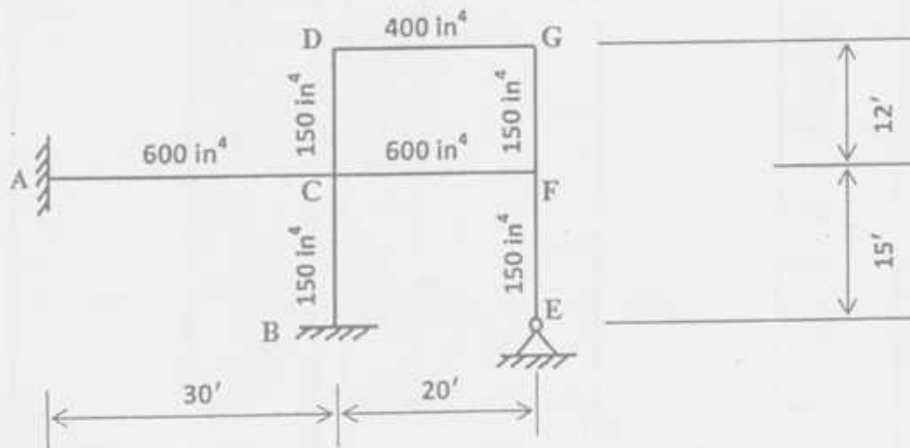

3. a) Write down the advantages of the structural steel as building materials. (6)
- b) A $10'' \times \frac{3}{4}''$ plate that is 5 ft long and has standard holes for $\frac{3}{4}''$ dia bolts one end (see Fig.) for attachment to other structural members, is to be used as a tension member. Using ASD method, determine the axial tension capacity of the steel A 36 steel member. Given: $U=0.85$ (4)

10" x 3/4" in section & 5 ft long

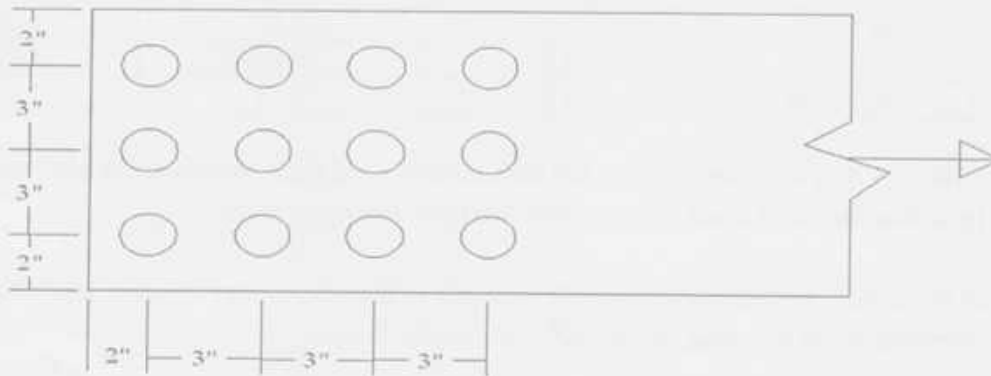

ANNEXURE 1: For Ques no 2 (b)

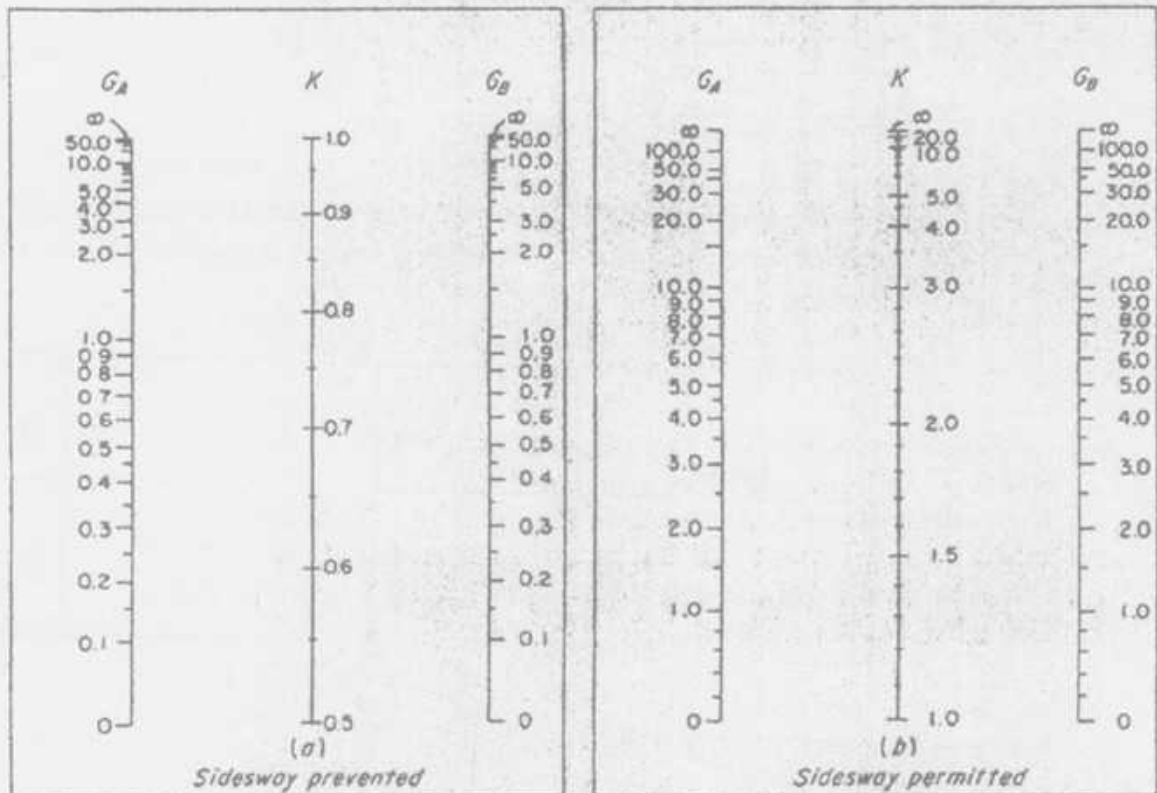

University of Asia Pacific
Department of Civil Engineering
Mid Semester Examination Fall 2014

Course No: CE 423
 Course Title: Structural Engineering IX
 (Earthquake Resistant Design and Retrofitting)

Time: 1 Hour
 Full Marks: 60

There are three questions. Answer all of them.

1. a) Derive equation of motion of a overdamped SDOF system with free vibration. (10)

b) A free vibration test is conducted on an empty elevated water tank. A cable attached to the tank applies a lateral force of 25 kips and pulls the tank horizontally by 3.5 in. The cable is suddenly cut and the resulting free vibration is recorded. At the end of four complete cycles, the time is 2.0 sec, the amplitude is 1.5 in. [Given, damping ratio= 3%] (10)

From these data compute the following:

- (i) natural period of undamped vibration,
- (ii) stiffness,
- (iii) weight,
- (iv) damping coefficient, and
- (v) number of cycles required for the displacement amplitude to decrease to 3 mm.

2. a) Write short note on: (i) Seismic base isolation system, (ii) High damping natural rubber bearing, (iii) Lead rubber bearing. (12)

b) Calculate the development length and anchorage length for an exterior beam column joint. [Given: $f'_c = 3000 \text{ psi}$, $f_y = 60000 \text{ psi}$, $A_s = 7 \text{ in}^2$, Bar diameter = 22 mm] (8)

3. The exterior joint shown in the Figure below is a part of a reinforced concrete frame designed to resist earthquake loads. A 6 in slab, not shown, is reinforced with No. 5 bars spaced 10 in center-to-center at the same level as the flexural steel in the beams. The member section dimensions and reinforcement are as shown. The frame story height in 12 ft. Material strengths are $f'_c = 4000 \text{ psi}$ and $f_y = 60000 \text{ psi}$. The maximum factored axial load on the upper column framing into the joint is 2500 kips, and the maximum factored axial load on the lower column is 3000 kips. Check if the joint satisfy weak beam strong column design as per ACI 318-08. (20)

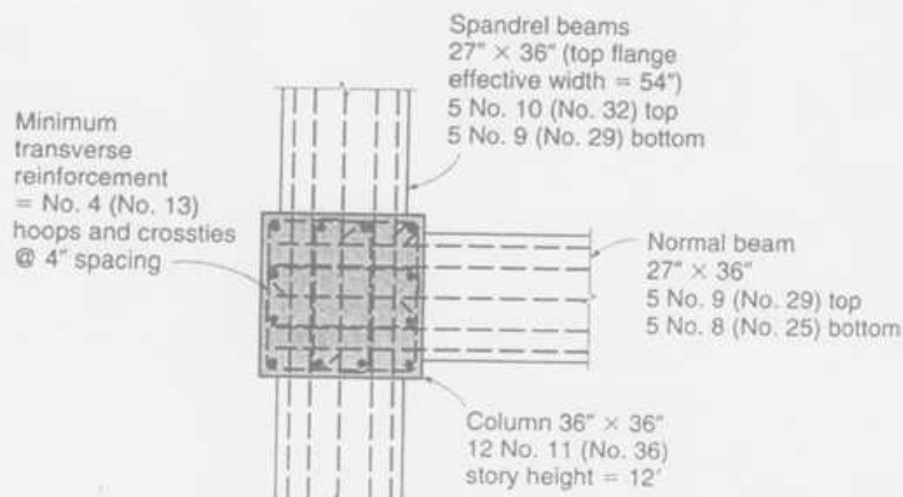

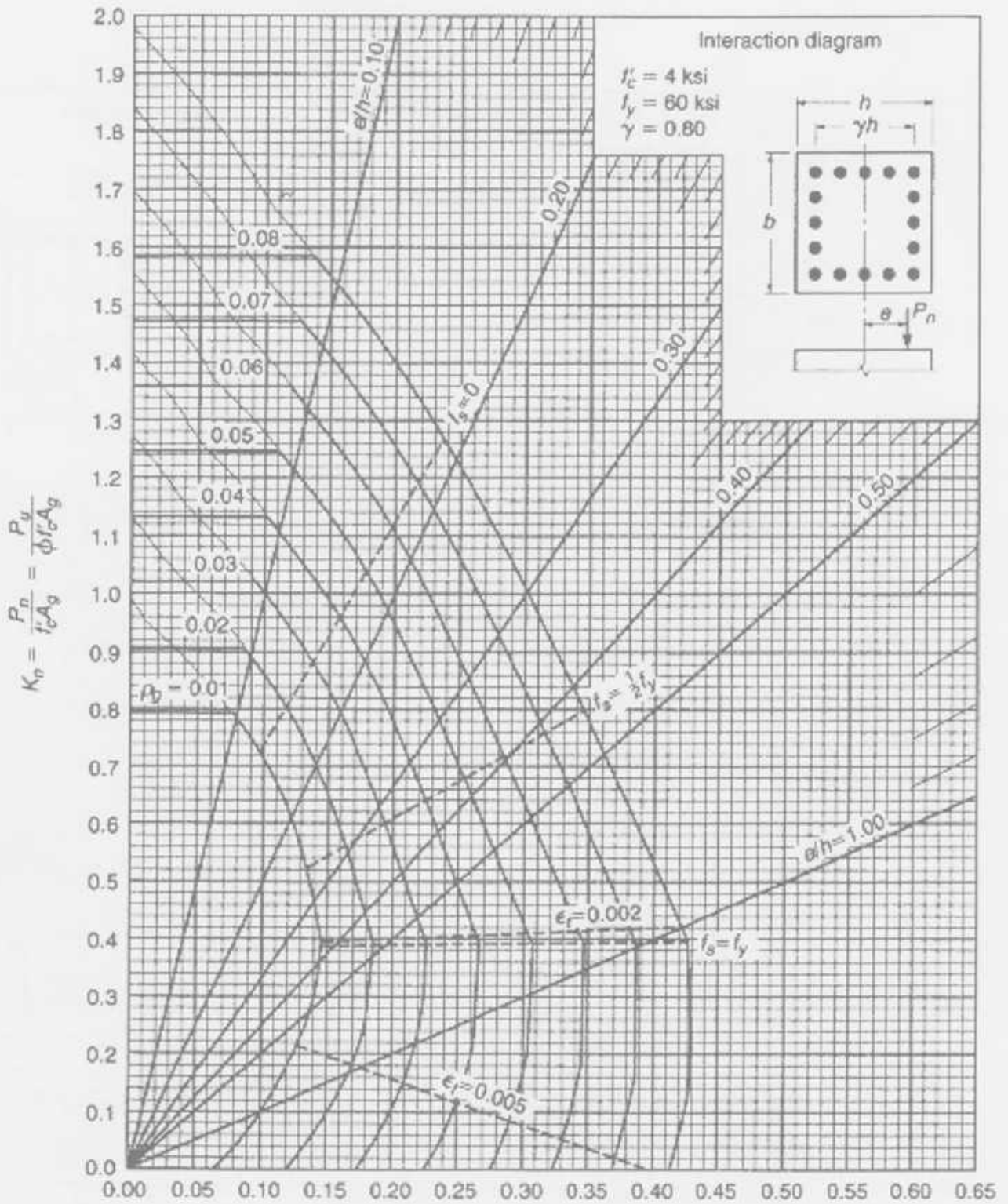

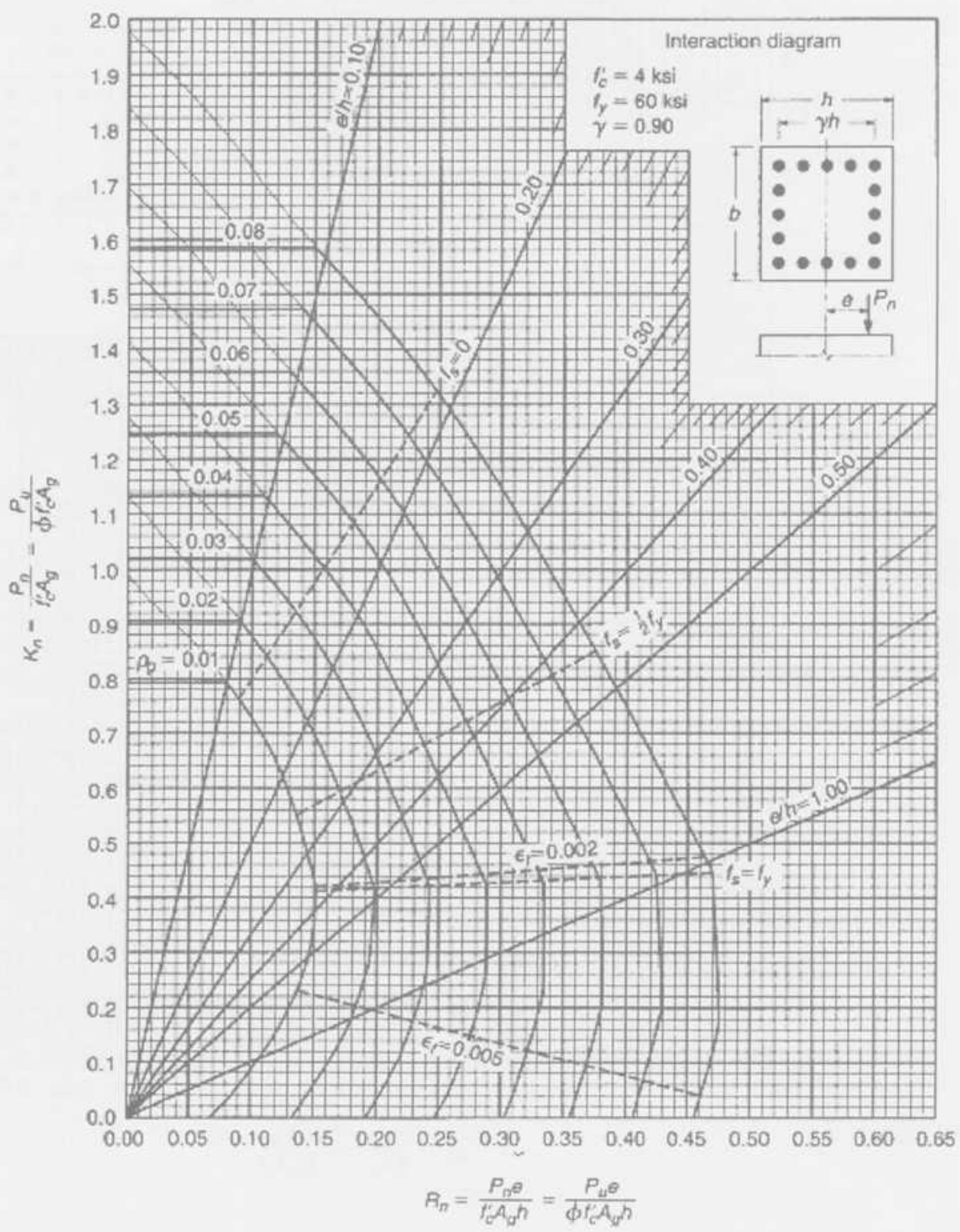

4-2

University of Asia Pacific
Department of Civil Engineering
Mid Semester Examination Fall 2014
Program: B.Sc. Engineering (Civil)

Course Title: Environmental Engineering III
 Time- 1 hour

Course Code: CE 431
 Full marks: 50

There are **THREE** questions. Answer any **TWO**. ($2 \times 25 = 50$)

1. (a) What is solid waste? Show the functional elements of solid waste management in a flow diagram. (6)

(b) Explain putrescible and non-putrescible types of solid waste. What are the factors on which the quantity of solid waste depends on? (7)

(c) Estimate the overall moisture content and energy content of a solid waste with the following composition: (12)

Component	% by Mass	Moisture Content (%)	Energy Content (KJ/Kg)
Paper	31.5	4.2	16900
Plastics	10.2	2.3	31300
Wood	4.6	18.7	19800
Textiles	8.8	9.5	18100
Leather	7.6	10.2	16800
Rubber	5.2	1.9	23400
Metals	12.1	1.3	27000
Food waste	13.6	82	4200
Miscellaneous	6.4	3.4	600

2. (a) What are the most important properties to be known if the solid wastes are to be used as fuel? (3)

(b) A summary table for the chemical components of a solid waste sample is given below. Determine approximate chemical formulas with and without sulfur. (12)

Component	Moisture	Carbon	Hydrogen	Oxygen	Nitrogen	Sulfur	Ash
Mass (kg)	25.60	50.20	5.56	35.00	0.45	0.26	7.14
Molar Mass (kg/mol)	-	12.00	1.00	16.00	14.00	32.00	-

(c) What is source reduction/waste minimization? List the beneficial consequences of source reduction in relation to climate change issues and list down the main strategic options for on-site processing.

(2+4+4)

3.(a) Classify Solid waste Collection System on the basis of availability of services and mention which among these are susceptible to scavenging. Which authority is responsible for overall solid waste management system in Dhaka and which collection system is mostly practiced here? (10)

(b) Solid wastes from a newly build up area is to be collected in large containers (drop boxes to be replaced). Based on traffic studies in similar type of areas, it is estimated that the average time to drive from the garage to the first container and from the last container to the garage each day will be 25 minutes and 40 minutes respectively. If the average time required to drive between containers is 5 minutes and the one way distance to the disposal site is 20 km (speed limit 72 km/h), determine the number of containers that can be emptied per day, based on 8-hr working day. Assume Off-route factor 0.15 for this case.

(15)

Given Formula:

Haul Container System	Stationary Container System
$P_{hcs} = pc + uc + dbc$ $T_{hcs} = P_{hcs} + s + a + bx$ $N_d = \frac{[(1 - W)H - (t_1 + t_2)]}{P_{hcs} + s + a + bx}$	$T_{scs} = P_{scs} + s + a + bx$ $P_{scs} = C_t uc + (n_p - 1)dbc$ $C_t = vr/cf$ $N_d = V_d/vr$ $H = \frac{(t_1 + t_2) + N_d(P_{scs} + s + a + bx)}{1 - W}$

Table 11-8 Typical data for computing equipment and labor requirements for hauled- and stationary-container collection systems

Collection	Vehicle	Loading method	Compaction ratio <i>r</i>	Pick up loaded container and deposit empty container, h/trip*	Empty contents of loaded container, h/container†	At-site time <i>s</i> , h/trip
Hauled-container systems						
	Tilt-frame	Mechanical		0.40		0.127
	Tilt-frame	Mechanical	2.0-4.0‡	0.40		0.133
Stationary-container systems						
	Compactor	Mechanical	2.0-4.0		0.050	0.10
	Compactor	Manual	2.0-4.0			0.10

* $pc + uc$ in Eq. (11-2).

† uc in Eq. (11-5).

‡ Containers used in conjunction with stationary compactor (see Fig. 11-7).

Table 11-7 Typical values for haul constant coefficients *a* and *b* in Eqs. (11-1), (11-3), (11-4), and (11-8)

Speed limit, km/h (mi/h)	<i>a</i> , h/trip	<i>b</i> , h/km (h/mi)
88 (55)	0.016	0.011 (0.018)
72 (45)	0.022	0.014 (0.022)
56 (35)	0.034	0.018 (0.029)
40 (25)	0.050	0.025 (0.040)

University of Asia Pacific
Department of Civil Engineering
Mid Semester Examination Fall 2014
Program: B.Sc. Engineering (Civil)

Course Title: Environmental Engineering IV
Time- 1 hour

Course Code: CE 433
Full marks: 60

Answer all of the questions below

Assume reasonable value for any missing data (if applicable)

1. (a) Briefly describe the most ideal and quite bad atmospheric conditions for dispersion of emission. Draw relevant figures. (10)
- (b) The ambient atmospheric temperature profile of an area is given by $t_a (^{\circ}\text{C}) = 25 - 0.002z$, where, z = altitude in m. If maximum surface temperature is 30°C and average wind speed is 5 m/s, estimate the variation coefficient (VC) and comment on the pollution potential. (10)
2. (a) Define temperature inversion. Briefly explain different types of temperature inversions. (2+4)
Mention the sources of indoor and outdoor air pollution. (4)
- (b) From a 150 m stack, with inside radius of 1m, exhaust gases leave with a velocity of 8 m/s at a temperature of 200°C . Ambient temperature is 25°C . Wind speed at effective stack height is estimated to be 4 m/s, surface wind speed is 2 m/s and it is a summer day with few broken clouds. Estimate the effective height of the stack. (10)
3. (a) Explain the most important particle deposition mechanisms in our respiratory system with relevant figures. (10)
- (b) Cars travelling at 70 mph speed at 60 m apart are emitting 2 g/mile of CO. The wind speed is 4 m/s and perpendicular to the road. Estimate ground level concentration of CO at a distance of 200 m downwind. Consider the atmosphere to be slightly stable. (10)

Formulae:

$$VC = MMD \times \bar{u}$$

$$F = gr^2 v_s (1 - T_a/T_s) \quad S = (g/T_a) (dT_a/dz + \Gamma)$$

$$\Delta h = 2.4 \times (F/uS)^{1/3} \quad \Delta h = \frac{1.6 F^{1/3} x_f^{2/3}}{u} \quad \begin{matrix} x_f = 120 F^{0.4} & \text{if } F \geq 55 \text{ m}^4/\text{s}^3 \\ x_f = 50 F^{5/8} & \text{if } F < 55 \text{ m}^4/\text{s}^3 \end{matrix}$$

$$\sigma_y = a \cdot x^{0.894}, \quad \sigma_z = c \cdot x^d + f$$

$$C(x, z) = \frac{Q_t}{\sqrt{2\pi\sigma_z u}} \times \left\{ \exp\left[\frac{-(z-H)^2}{2\sigma_z^2}\right] + \exp\left[\frac{-(z+H)^2}{2\sigma_z^2}\right] \right\}$$

Table 1: Atmospheric Stability classes

Surface wind speed ² (m/s)	Day solar insolation			Night cloudiness ³	
	Strong ^b	Moderate ^c	Slight ^d	Cloudy ($\geq 4/8$)	Clear ($\leq 3/8$)
< 2	A	A-B ¹	B	E	F
2-3	A-B	B	C	E	F
3-5	B	B-C	C	D	E
5-6	C	C-D	D	D	D
> 6	C	D	D	D	D

¹Surface wind speed is measured at 10 m above the ground.

²Corresponds to clear summer day with sun higher than 60° above the horizon.

³Corresponds to a summer day with a few broken clouds, of a clear day with sun 35-60° above the horizon.

⁴Corresponds to a fall afternoon, or a cloudy summer day, or clear summer day with the sun 15-35° above the horizon.

⁵Cloudiness is defined as the fraction of sky covered by clouds.

⁶For A-B, B-C, or C-D conditions, average the values obtained for each.

Note: A, Very unstable; B, moderately unstable; C, slightly unstable; D, neutral; E, slightly stable; F, stable. Regardless of windspeed, class D should be assumed for overcast conditions, day or night.

Source: Turner (1970).

Table 2: Values of constant a, c, d and f to estimate σ_y and σ_z

Stability	a	$x \leq 1 \text{ km}$			$x \geq 1 \text{ km}$		
		c	d	f	c	d	f
A	213	440.8	1.941	9.27	459.7	2.094	-9.6
B	156	106.6	1.149	3.3	108.2	1.098	2.0
C	104	61.0	0.911	0	61.0	0.911	0
D	68	33.2	0.725	-1.7	44.5	0.516	-13.0
E	50.5	22.8	0.678	-1.3	55.4	0.305	-34.0
F	34	14.35	0.740	-0.35	62.6	0.180	-48.6

¹ The computed values of σ will be in meters when x is given in kilometers.

Source: Martin (1976).

University of Asia Pacific
Department of Civil Engineering
Midterm Examination Fall 2014
Program: B.Sc. Engineering (Civil)

Course code: CE 439

Course title: Environmental Engineering VII (Environmental Impact Assessment)

Time: 60 Minutes

Full marks: 20

Answer ALL questions

1. Define the following: (6)
 - Impact
 - Environmental Impact Assessment (EIA)
 - Screening
 - Initial Environmental Examination
 - Scoping
 - Impact analysis
2. Write four long time objectives of EIA (1)
3. Draw the flow diagram of EIA process and parallel studies (3)
4. According to Article 7 of the Bangladesh Environmental Conservation Rules (1997), write the procedures to obtain environmental clearance certificate for a red category factory? (2.5)
5. Explain different levels and forms of public involvement (2)
6. Write the benefits of public participation during EIA process for the following stakeholder groups: (3)
 - The proponent/supporter
 - The decision-maker
 - Affected communities(Write three benefits for each stakeholder group)
7. Write four possible outcomes of screening process in EIA (1.5)
8. What are the common formal methods used for impact identification in an EIA process? (1)

University of Asia Pacific
Department of Civil Engineering
Mid-Term Examination, Fall 2014

Course # CE 441
 Full Marks: 40 (10 X 4 = 40)

Course Title: Geotechnical Engineering II
 Time: 1 hour

Answer any four (4) of the following five (5) questions

1. (a) Mention four major purposes of geotechnical subsurface exploration. 4
 (b) Mention the steps/phases of a geotechnical sub-surface exploration program. 2
 (c) Write down any four (4) general guidelines used for the selection of location of boreholes. 4

2. Column load at a location for a site is estimated to be 240 Kips. The site is explored to a depth of 50 feet below EGL. Assuming an anticipated bearing capacity of 2.0 ksf for a rectangular footing check whether the exploration is sufficient or not. Consider the foundation level to be about 6 feet below EGL, $B = 10$ ft and $L = 1.2B$. Justify your answer with the aid of some calculations related to significant induced stress. 10

3. Discuss about the occurrence of disturbances (in terms of overburden stress, sample aggregation and degree of disturbances (DOD) of the sampler; for Shelby Tube (ST): $D_o = 76$ mm, $D_i = 73$ mm and for Split Spoon Sampler (SSS): $D_o = 51$ mm, $D_i = 35$ mm) during sampling phase of geotechnical subsurface exploration. 10

4. A geotechnical site investigation was conducted at a site in Bangladesh. Estimate n_3 at corresponding depth of 20 ft below EGL. Also estimate z as shown in the figure below. Use APPENDIX A in conjunction with the following information: 10
 - Borehole dia = 4 inches
 - No liner was used during drilling
 - Hammer efficiency as 52.6%

n_1 = SPT blow counts for first 6-inch penetration
 n_2 = SPT blow counts for second 6-inch penetration
 n_3 = SPT blow counts for third 6-inch penetration

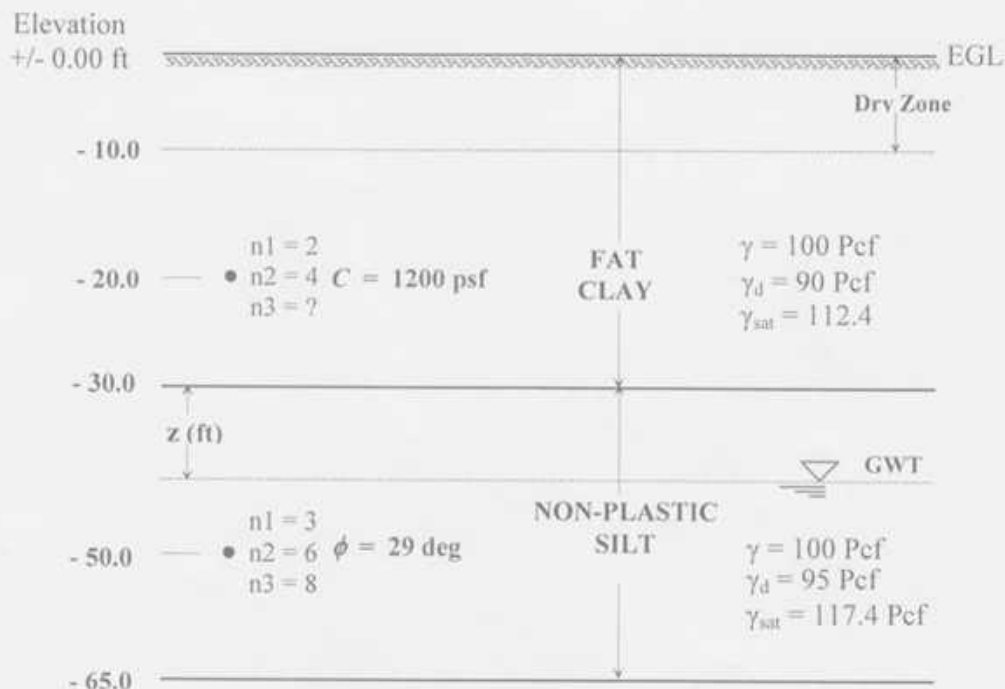

Subsurface Soil Stratigraphy

5. (a) Draw neat sketches of local and punching shear failures.

3

(b) Using Terzaghi's bearing capacity equation (TBCE), determine the allowable column load for the following circular spread footing. Use F. S. = 2.5.

7

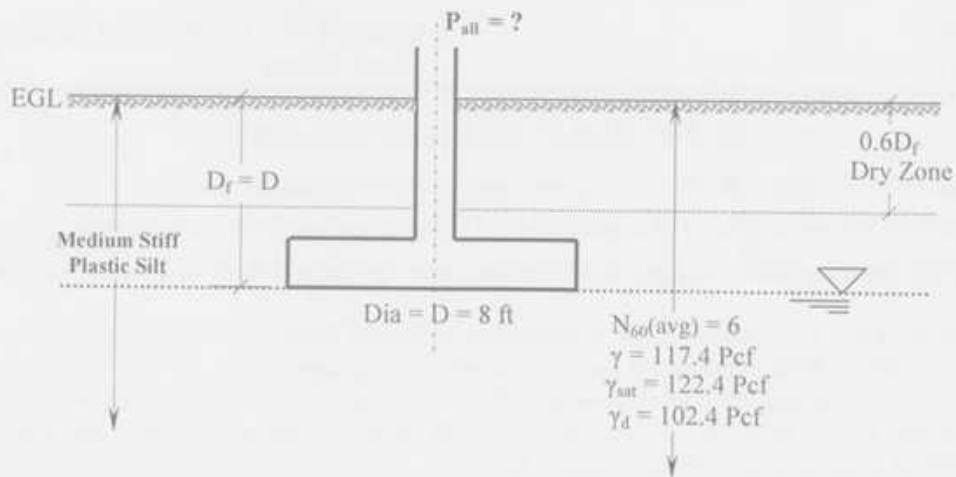

University of Asia Pacific
Department of Civil Engineering
Mid-term Examination, Fall 2014
Program: B.Sc. Engineering (Civil)

Course Number: CE 451

Course Title: Transportation Engineering II

Full Marks: 50

Time: 1 hour

Answer any 5 (five) questions from the following 6 (six) questions

1. (a) What is permanent way? (1)
 (b) Draw the diagram of different types of rail with proper labeling. (6)
 (c) What is deficiency in super-elevation? (3)
2. (a) Write down the comparisons between long length rail and short length rail? (3)
 (b) Define: shift, cant deficiency, ruling gradient (3)
 (c) Write down the methods adopted to reduce wear of rails. (4)
3. (a) What are the purposes of transition curve? (3)
 (b) Define: undercut switch, over-riding switch (2)
 (c) Draw the cross-section of a rail line with proper labeling. (5)
4. (a) What is easement curve? Explain with proper diagram. (3)
 (b) What are the classifications of signals, when train is approaching toward station? (4)
 (c) Write down the comparisons between heel blocks and stretcher bars. (3)
5. (a) Write down the comparisons between check rail on curve and tongue rail. (3)
 (b) Define: facing direction, signaling (2)
 (c) Write down the advantages of flat footed rails. (3)
 (d) What are the functions of blanket layer? (2)
6. (a) Compare loose heel type switch and fixed heel type switch. (3)
 (b) What are the types of crossings? Explain with proper diagram. (1.5+1.5)
 (c) Write down the comparisons between screw-spikes and dog-spikes? (2)
 (d) In track maintenance, which parts of rail are included to maintenance? (2)

University of Asia Pacific
Department of Civil Engineering
Midterm Examination Fall 2014
Program: B.Sc. Engineering (Civil)

Course code: CE 461

Course title: Irrigation and Flood Control

Time: 60 Minutes

Total marks: 60

There are TWO sections in the question paper namely "SECTION A" and "SECTION B". You have to answer from the both sections according to the instruction mentioned on each section.

SECTION A
MARKS: 45

Answer all questions

1. Write the benefits of irrigation and the harmful effects of excess irrigation. (4.5)
2. A sample of water from a well showed that it has an electrical conductivity of 1 mmhos/cm and a density of 1 gm/cm³. A field with a bulk density of soil of 1.48 gm/cm³ and saturation point of 36 percent will be irrigated. Find out the depth of irrigation that may turn the 30 cm depth of soil saline ignoring the precipitation and leaching of salts that may occur. (9)
3. Explain the precautions needed while using saline water in irrigation. (6)
4. a) What are the different methods of irrigation water distribution? (4.5)
b) Explain furrow irrigation method along with sketch. (4.5)
5. a) What is the classification of irrigation water having the following characteristics: Concentration of Na, Ca and Mg are 30, 2 and 2.5 milli-equivalents per liter respectively, and the electrical conductivity is 300 μ mhos/cm at 25° C? (4.5)
b) What problems might arise in using this water for irrigation? (3)
c) What remedies do you suggest to overcome this trouble? (3)
6. Explain soil moisture tension and soil moisture stress. (6)

SECTION B
MARKS: 15

Answer question number 7 and any one from the rest

7. a) Define flood. What are the causes of flood? (1.5+3)
b) Define river. What are the functions of a river? (1.5+3)
8. Explain the following (any four) (1.5x4)
- Catastrophic flood
 - Flash flood
 - Drainage congestion
 - Design flood
 - Flood and the poor
9. Explain impacts of flood. (6)

University of Asia Pacific
Department of Civil Engineering
Mid term Examination Fall 2014
Program: B.Sc. Engineering (Civil)

Course Title: Chemistry
Time: 1 hour

Course Code: CHEM 111
Full Marks: 60

There are *four* questions. Answer *any three* questions.

1. (a) What is lattice energy of ionic solids? Draw the Born-Haber cycle for determining the lattice energy of NaCl. [2+3]
(b) What is meant by isoelectronic? Which pair of the following species is isoelectronic? [3+2]
$$\text{Na}^+, \text{Zn}^{2+}, \text{Mg}^{2+}, \text{Ca}^{2+}$$

(c) Predict the geometry of the H_2O , NF_3 , PCl_5 , XeF_4 molecules by VSEPR model. You must show your work (all steps) to get full credit on this question. [10]
2. (a) Can you explain why NH_3 has such a large dipole moment compared with NF_3 ? [5]
(b) Define bonding and anti-bonding molecular orbital. [5]
(c) Draw the molecular orbital diagram of O_2 molecule. Is this molecule diamagnetic or paramagnetic? What is the bond order of O_2 ? [6+2+2]
3. (a) What is wave function, ψ ? What are the physical significances of ψ^2 ? [5]
(b) Write down all possible quantum numbers for $n = 2$. Sketch the general shape and orientations of the 2p orbitals. [4+3]
(c) Define ionization energy and electron affinity. How do they change in the periodic table? [5+3]
4. (a) Estimate the vapor pressure of water at 50°C in mmHg unit. Note that the normal boiling point of water is 100°C and that its heat of vaporization is 40.7 kJ/mol . [6]
(b) Draw and label the phase diagram of CO_2 . Calculate the degrees of freedom using the phase rule at all the regions, curves and the triple point. [4+5]
(c) The critical temperature of NH_3 and N_2 are 132°C and -147°C , respectively. Which one of these two gases can be liquefied easily at room temperature? Explain. [5]

University of Asia Pacific
Department of Civil Engineering
Mid-Semester Examination Fall-2014

Program: B. Sc Engineering (2nd Year / 1st Semester)

Course Title: Basic Electrical Engineering Course No. ECE (CE) 201 Credits: 3.00
 Time: 1.00 Hour. Full Marks: 60

There are **Four** Questions. Answer any **Three**. Figures in the right margin indicate marks.

1. (a) If $R_{eq}=50\Omega$ in the following circuit, find R . (10)

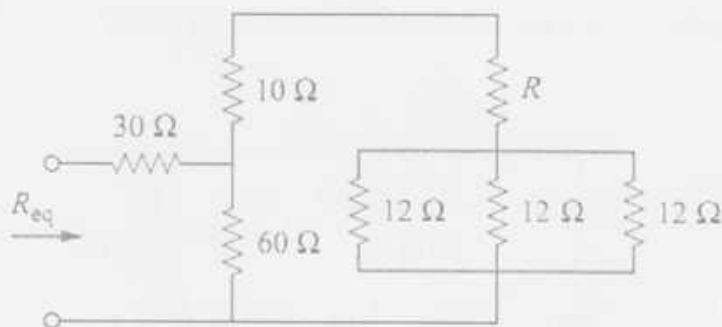

Circuit diagram for question 1(a)

- (b) Find I and V_s in the following circuit if the current through the 3- Ω resistor is 2A. (10)

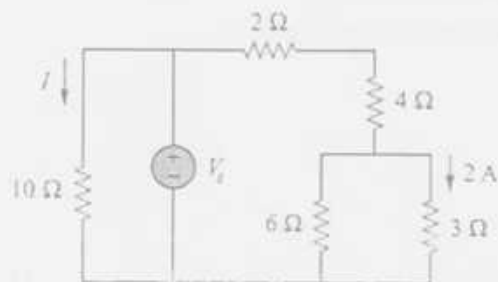

Circuit diagram for question 1(b)

2. (a) Find v_1 , v_2 and v_3 in the following circuit using nodal analysis. (10)

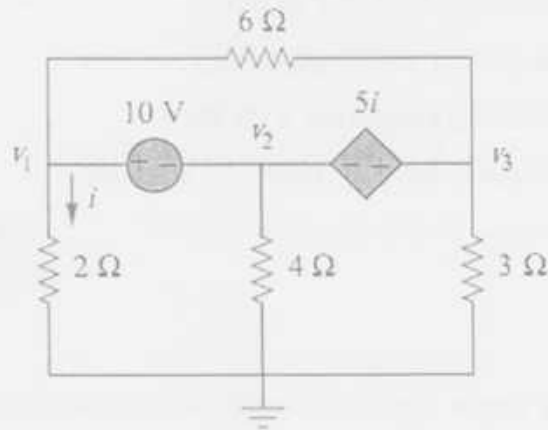

Circuit diagram for question 2(a)

- (b) Use mesh analysis to find the current i_o in the following circuit (10)

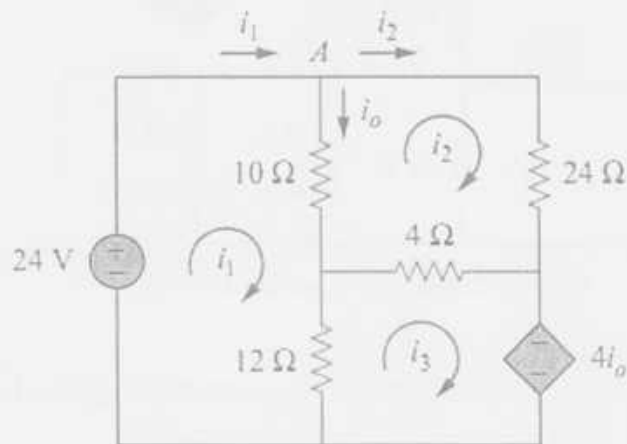

Circuit diagram for question 2(b)

3. (a) Write Short notes on the following terms : (10)

- i. Ohm's Law
- ii. KCL
- iii. KVL
- iv. Superposition theorem
- v. Thevenin's theorem

(b) Determine V_o in the following circuit using superposition principle. (10)

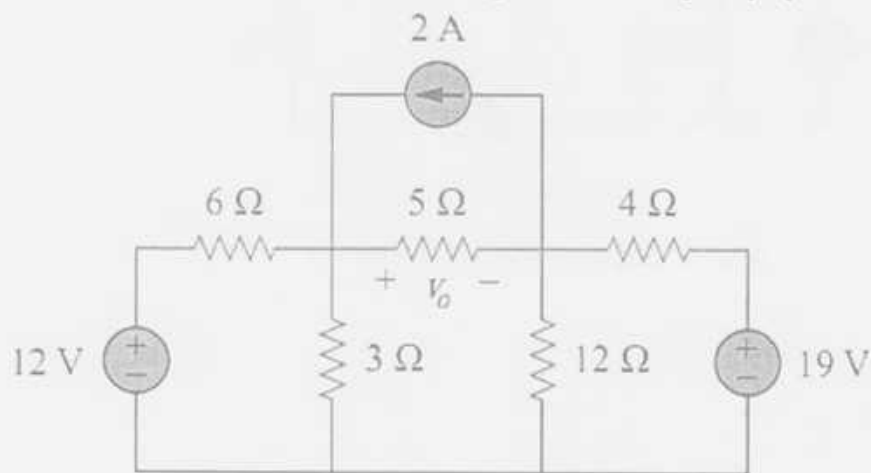

Circuit diagram for question 3(b)

4. (a) Find i_o in the following circuit using source transformation. (10)

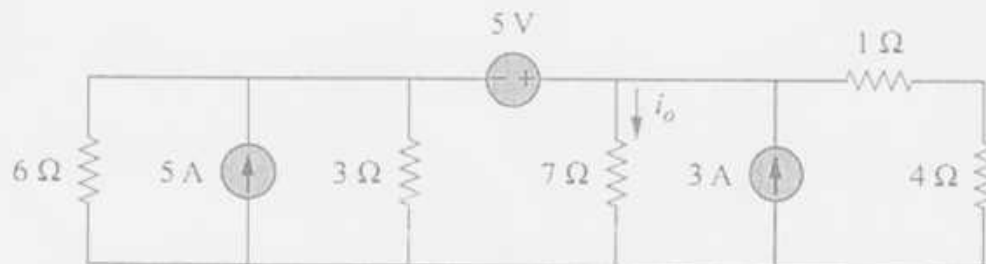

Circuit diagram for question 4(a)

- (b) (i) For the following circuit, obtain Thevenin's equivalent at terminal a-b (10)
a-b
(ii) Calculate the current at $R_L=8\Omega$
(iii) Find R_L for maximum power delivered to R_L .
(iv) Determine the maximum power

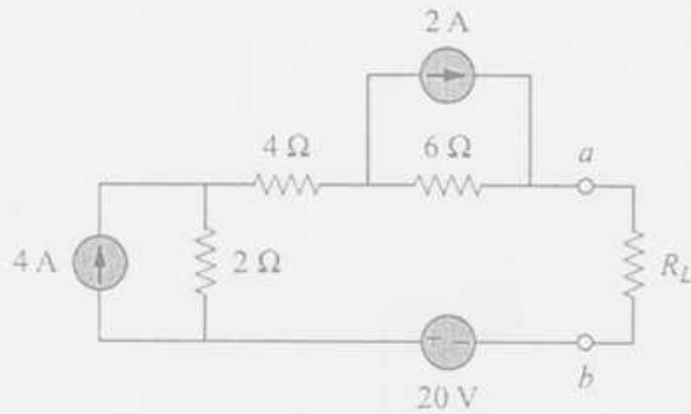

Circuit diagram for question 4(b)

University of Asia Pacific
Department of Civil Engineering
Mid-Term Examination, Fall-2014
Program: B.SC Engineering (2nd Year/2nd Semester)

Course Title: Principle of Economics

Course Code: ECN 201

Credit: 2.00

Time: 1 Hour

Full Marks: 20

Answer any **four** from the following questions:

1. (a) Explain the relationship between elasticity and revenue. (3)

(b) Find the equilibrium price and quantity from the following markets: (2)

$$Q_d = 180 - 2P, Q_s = -90 + 3P$$

2. Explain the Diminishing Law of Marginal Utility. (5)

3. (a) Write short note on : Production Possibility Frontier (2)

(b) Given the demand function, $P_d = 145 - Q^2$ and supply function, $P_s = (Q+1)^2$ (3)

Find the Consumers' Surplus and Producers' Surplus.

4. (a) Define : Cross price elasticity , Income elasticity, Price elasticity of demand. (2)

(b) Calculate the cross price elasticity of demand between Tea and Coffee (3)

Here Tea is good 1 and Coffee is good 2

	Before		After	
	Price [Tk]	Quantity [Units/month]	Price [Tk]	Quantity [Units/month]
Tea	30	40	50	10
Coffee	45	15	40	45

5. How can one get ATC curve from AFC and AVC curve. Show graphically. (5)

University of Asia Pacific
Mid Semester Examination (Fall 2014)
Program: B.Sc. Engineering
Department of Civil Engineering
Year: 1st, Semester: 1st

Course Code: HSS101

Course Title: English Language I

Time: 1Hour

Full Marks: 20

*Marks are indicated in the right margin

1. Read the following passage and answer the questions that follow: (6x1=6)
1. On January 21 1793, a Square in Paris known as the Place de la Revolution was packed with men,
2. women and children. In the middle of the Square stood the guillotine, which was used by the
3. French to put to death criminals and traitors. Suddenly a cry rose from the people waiting there.
4. The man whom they had come to see executed came into sight in an open cart. The cart stopped at
5. the foot of the ladder which led up to the platform where the guillotine stood. The man got down
6. from the cart. He climbed the ladder and fell on his knees under the sharp blade, which dropped
7. and cut off his head. The head of the lifeless man fell into the basket. The head that fell was the
8. head of Louis XVI, who had been crowned King of France in 1774. ...
- a. Write a synonym of the word "packed" in the first (1st) line.
b. What is the verb of the word "death" in the second (2nd) line?
c. Find out the components (Subject/ Verb/ Complement/ Adverb) of the fourth (4th) sentence.
d. Find two noun phrases from the sixth (6th) line.
e. Find a suffix in the seventh (7th) line and make two words using that suffix.
f. Use the word "crown" as a *noun* and a *verb* in two separate sentences.
2. Identify the parts of speech (adjective, adverb, noun, etc.) of the words underlined: 2
- a. I first met her a year ago.
b. These boys come to our library every Thursday.
c. I know the man.
d. Styles in clothing change rapidly.

3. Write 5 arguments (for/ against) on any one of the following: 5
- a. "Is homework helpful or harmful for university students?"
 - b. "Teenagers should/ should not take their own decisions."
4. Use the following phrases in sentences: 2
- a. ... over 5 kgs in weight
 - b. ... away from home
 - c. ... by my brother
 - d. ... with surprise
5. Use the following words in a single sentences: 3
- a. Allowed, aloud
 - b. Scent, cent
 - c. Ate, eight
 - d. Thrown, throne
 - e. Watch (verb), watch (noun)
 - f. Play (verb), play (noun)
6. Use suffix/prefix to the following words and use them in sentences as directed: 2
- a. Fashion (into adjective)
 - b. Honest (into adverb)
 - c. Large (into verb)
 - d. Fresh (into verb)

University of Asia Pacific
Department of Civil Engineering
Mid Semester Examination (Fall 2014)
Program: B.Sc. Engineering
Year: 1st Semester: 2nd

Course Title: English Language II
Time: 1 Hour

Course Code: HSS 103 Credit: 3.00

Full Marks: 20

1. Rewrite the following sentences correctly:

03

- (a) The team and the coach (was/ were) on the field.
- (b) Neither the chicken nor the cats (was/ were) infected.
- (c) Either Miraj or you (was/ were) selected.
- (d) Everyone selected to serve on this jury (have/ has) to be willing to work honestly.
- (e) The poetry written by Shakespeare (is/ are) mesmerizing to read.
- (f) Many poor men (live/ lives) in Dhaka City.

2. Change the forms of voice of the following sentences (any 6):

03

- (a) May the computer be bought by me?
- (b) Breakfast might have been eaten by him.
- (c) Recently, the work has been done by Jahan.
- (d) My mother is going to make a delicious dinner tonight.
- (e) The bills used to be paid by my uncle.
- (f) Tuhin was not counting the coins.
- (g) Will Jamal teach his brother?
- (h) He will have known it by this time.

3. Change the forms of speeches of the given sentences:

03

- (a) Rahim said, "May I smoke?"
- (b) He said, "all tickets must be bought in advance."
- (c) He asked, "Where does she live?"
- (d) Sultana said, "Let the old man have some food."
- (e) I said to him, "Please help me."
- (f) The mother said to her son, "Do not laugh at the poor".

4. Complete the following sentences using the correct conditional structures: 03

- (a) If I become a doctor,
- (b) If you are suffering from fever,.....
- (c) If I worked in this industry a good salary.
- (d) If you had thought about it beforenow.
- (e), I would ask a lawyer for some advice.
- (f) If you had rung me, I

5. Make sentences with any six (06) of the following phrases: 03

- (a) In black and white:
- (b) Storm in teacup:
- (c) Fight tooth and nail:
- (d) Day in day out:
- (e) Blow one's own trumpet:
- (f) Fish out of water:
- (g) Break the ice:
- (h) A bird's eye view:

6. Write one synonym and one antonym of any one (01) of the given words and make sentences with those synonyms and antonyms: 02

- (a) Deliberate
- (b) Haphazard

7. Make sentences with any three (03) of the following pair of words: 03

- (a)
Custom:
Habit:
- (b)
Compare:
Contrast:
- (c)
Drown
Sink:
- (d)
Publicity:
Propaganda:

University of Asia Pacific
Department of Basic Sciences and Humanities
Mid Semester Examination, Fall 2014
Programme: B. Sc. Engineering (Civil)
(2nd Year 1st Semester)

Course Title: Bangladesh Studies: Society and Culture Course Code: HSS 211(a)

Credit: 2.00

Time: 1 Hour

Full Marks: 40

There are FIVE questions. Answer ANY FOUR (4x10)

1. What does sociology deal with? Is sociology a normative science? 8+2
2. Mention the sub-fields of sociology? Discuss any two. 2+8
3. Define the family. Discuss the changing functions of the family. 3+7
4. Is sociology a scientific discipline? Discuss the steps of sociological research. 3+7
5. What is participant observation? Discuss its strengths and limitations. 3+7

University of Asia Pacific

Department of Basic Sciences and Humanities

Mid Semester Examination, Fall - 2014

Programme: B.Sc. Engineering (CIVIL)

2nd year 1st semester

Course Title: Bangladesh Studies: History

Course Code: HSS 211(b)

Credit: 2.00

Time: 1 Hour

Full Marks: 40

There are FIVE questions below. Answer ANY FOUR (4 x 10)

1. Write in brief about the background of the name 'Bangladesh'.
2. Which dynasty ruled Bengal for 400 years? Who was the founder of this dynasty? How did he come to power?
3. Who offered all facilities to Sri Chaitannya in his religious propagation? What do you know about his literary appreciation and role in spreading Islam?
4. Who were the Bara Bhuiyans? How did the Mughals at last suppress them?
5. What were the Janapadas? What are the present locations of different Janapads of ancient Bengal?

University of Asia Pacific
Department of Civil Engineering
Mid term Examination Fall 2014
Program :B.Sc Engineering (Civil)

Course Title Principle of Management
Time: 60 Mins.

Course Code: IMG 301
Full Marks: 20

Answer all questions

1. What are the 3 Key Elements of Motivation? List 5 methods for motivating employees. [5]
2. Identify 5 Levels of Maslow's hierarchy needs. Give examples for each. [2.5]
3. What are the 4 Decision Making situations? Give examples for each. [2]
4. List 4 Decision Making Styles with examples for each. [2]
5. Draw an organisational chart for a Bridge Construction Project. Include 3 types of structure. [2.5]
6. Construct a Stakeholder map for a Road Construction Project in a residential area. [3]
7. What are the Functions of Management? Give examples in each. [3]

University of Asia Pacific
Department of Basic Sciences & Humanities
Mid Semester Examination, Fall-2014
Program: B.Sc. Engineering (Civil)
1st year/1st semester

Course Name: Mathematics-I
 Time: 1 Hour

Course Code: Math 101
 Full Marks: 60

N.B.: Answer any 3 (THREE) questions. Figures in the right margin indicate the marks of the respective questions.

- Q1. (a) Define injective function and bijective function with examples. 8
 (b) Define domain and range of a function $f(x)$. Sketch and determine the domain and range of the following functions (any two): 12

(i) $f(x) = x^2 - 3x + 2$ (ii) $f(x) = 2x + |2 - x|$ (iii) $f(x) = \frac{x^2 - 4}{x - 2}$

- Q2. (a) Define continuity of a function $f(x)$ at a point $x = a$. Find the value of k for which the function 11

$$f(x) = \begin{cases} \frac{x^2 - 9}{x - 3}, & x \neq 3 \\ k, & x = 3 \end{cases}$$

will be continuous at $x = 3$.

- (b) Define $\delta - \epsilon$ definition of limit of $f(x)$ at $x = a$. Prove that $\lim_{x \rightarrow 3} x^2 - 5 = 4$ 9

- Q3. (a) Define continuity from the left and continuity from the right. Test the continuity of $f(x) = \sqrt{25 - x^2}$ on $[-5, 5]$. 14

- (b) Test the continuity of $f(x) = \begin{cases} x \sin(1/x) & \text{if } x \neq 0 \\ 0 & \text{if } x = 0 \end{cases}$ at $x = 0$. 6

- Q4. (a) Define instantaneous rate of change and average rate of change. Find instantaneous rate of change and average rate of change $f(x) = \frac{x^2}{2}$ over $[3, 4]$. 13

- (b) A 17 ft. ladder is leaning against a wall. If the bottom of the ladder is pulled along the ground away from the wall at a constant rate of 5 ft/sec, how fast will the top of the ladder be moving down the wall when it is 8 ft. above the ground? 7

1-2

University of Asia Pacific
Department of Basic Sciences & Humanities
Mid Semester Examination, Fall-2014
Program: B.Sc. Engineering (Civil)
1st year/ 2nd semester

Course Title: Mathematics II	Course Code: MTH 103	Credit: 3.00
Time: 1 hr		Full Marks: 60

Answer any **THREE** of the following questions: **3×20 = 60**

1. (a) By the transformation of the rectangular co-ordinate axes without changing the direction of axes deduce the transformation, $x = x' + \alpha, y = y' + \beta$. 12
- (b) Remove the first degree terms in the equation: 8
$$2x^2 + 5y^2 - 12x + 10y - 7 = 0$$
2. (a) Show that the equation $2y^2 - xy - x^2 + 2x + y - 1 = 0$ represents a pair of straight lines; also find their point of intersection and the angle between them. 13
- (b) Find for what value of δ the equation $x^2 - 4xy - y^2 + 6x + 8y + \delta = 0$ represents a pair of straight lines. 7
3. (a) Define Direction Cosines of a line. 8
- (b) If P & Q are (1, -5, 7) and (-3, 6, -2) and O be the origin, find the direction cosines of OP, OQ and PQ. Also find the angle POQ. 12
4. (a) Find the projection of the joining the points (-1, 3, 5) and (2, 0, -6) on the line through the points (3, -6, 1) and (7, 6, -2). 10
- (b) Find the equation of the plane through the points (2, 1, -3), (3, -1, 4), (7, 5, 6). 10

University of Asia Pacific
Department of Basic Sciences & Humanities
Mid Semester Examination, Fall-2014
Program: B.Sc. Engineering (Civil)
2nd year/ 1st semester

Course Title: Mathematics III
 Full Marks: 60

Credit: 3.00

Course Code: MTH-201
 Time: 1(one) hour

Answer any **Three** of the followings questions:

3×20 = 60

1. (a) Define inverse of a matrix. Does the inverse of a square matrix always exist? (10)

Make your comments. Find A^{-1} and $A^{-1}A$ for the matrix $A = \begin{pmatrix} 1 & -5 \\ 0 & -1 \end{pmatrix}$.

- (b) Solve for the following system of linear equations by using matrix method. (10)

$$2x + y - z = 2$$

$$x + 2y + z = 1$$

$$3x - y + 2z = 9$$

2. (a) Solve the following system by using Gauss- Jordan Elimination. (10)

$$3x + 5y - z = -7$$

$$x + y + z = -1$$

$$2x + 11z = 7$$

- (b) An investor deposited \$80,000 in a savings bank, some at annual rate of 10% and the rest at half yearly rate of 6%. At the end of a year, he received annual interest of \$9000. Using matrix method find out how much he deposited at 5%. (10)

3. (a) Define linear combination. Determine whether or not the vector (1, 2, 6) is a linear combination of the vectors (2, 1, 0), (1, -1, 2) and (0, 3, -4). (10)

- (b) Define linear dependence and independence of vectors. Determine whether the vectors (1, -2, 1), (0, -1, 0) and (2, 0, 2) in \mathbb{R}^3 are linearly dependent or independent. (10)

4. (a) Determine the value of a such that the following system of equations x , y and z has: (i) a unique solution, (ii) no solution (iii) more than one solution (12)

$$ax + y + z = 1$$

$$x + ay + z = 1$$

$$x + y + az = 1$$

- (b) Define the terms Euclidean inner product, norm and distance in \mathbb{R}^n and \mathbb{C}^n . Find the Euclidean norms of \underline{u} and \underline{v} ; inner product $\underline{u} \cdot \underline{v}$ where $\underline{u} = (2 + 3i, 1 + i, 3 + 7i)$, $\underline{v} = (4 - 5i, 3i, 5 + 4i)$. (8)

University of Asia Pacific
Department of Basic Sciences & Humanities
Mid Semester Examination, Fall-2014
Program: B.Sc. Engineering (Civil)
2nd Year / 2nd Semester

Course Title: Mathematics IV
Time: 1 hr

Course Code: MTH 203
Full Marks: 60

Answer any **three** of the followings:

3×20 = 60

1. (a) Define Differential Equation, Partial Differential Equation, Order & Degree of a Differential Equation, and Linear & Non-Linear Differential Equation with example. 12
- (b) Form a Differential Equation whose solution is $y = e^{2x}(A \sin x + B \cos x)$ 8

2. Define first order linear differential equation. Solve any three equations: 20
 - i) $x \sin y dx + (x^2 + 1) \cos y dy = 0$
 - ii) $(3x^2 + 4xy) dx + (2x^2 + 2y) dy = 0$
 - iii) $(x^2 + 3y^2) dx - 2xy dy = 0$
 - iv) $(2x^2 + y) dx + (x^2 y - x) dy = 0$

3. Define Bernoulli Equation. Solve any three equations: 20
 - i) $y^2 dx + (3xy - 1) dy = 0$
 - ii) $dy + y dx = xy^3 dx$
 - iii) $dy + (y/2x) dx = (x/y^3) dx$
 - iv) $x dy + y dx = (xy)^{3/2} dx$

4. Solve any four (4) equations: 20
 - i) $y'' - y' - 12y = 0, y(0) = 3, y'(0) = 5$
 - ii) $y'' + 7y' + 10y = 0, y(0) = -4, y'(0) = 2$
 - iii) $y'' + 2y' + 5y = 0, y(0) = 2, y'(0) = 5$
 - iv) $9y'' + 6y' + 5y = 0, y(0) = 6, y'(0) = 0$
 - v) $y'' - 6y' + 25y = 0, y(0) = -3, y'(0) = -1$

University of Asia Pacific
Department of Basic Sciences and Humanities
Mid-Semester Examination Fall - 2014
Program: B. Sc Engineering (CE)

Course Title: Physics I
Time: 1.00 Hour

Course Code: PHY-101

Credit: 3.00
Full Mark: 60

N.B- There are **Four** Questions. Answer any **Three**. All questions are of equal value. Figures in the right margin indicate marks.

1. (a) Prove that in case of longitudinal strain, the work done per unit volume is equal to $\frac{1}{2} \times \text{Stress} \times \text{Strain}$. [10]
(b) Find the work done in stretching a wire of 1 sq mm cross section and 2 meter long through 0.1 mm. Given that $Y = 2 \times 10^{11} \text{ N/m}^2$. [10]
2. (a) What do you understand by the term Poisson's ratio? Show that the maximum possible value of Poisson's ratio is equal to $\frac{1}{2}$. [10]
(b) A steel wire of 8 m long and 4 mm in diameter is fixed to two rigid supports. Calculate the increase in tension when the temperature falls by 10°C . [10]
3. (a) Show that the moment of inertia of a uniform rod is $\frac{1}{12}ML^2$, where the symbols have their usual meanings. Consider that the axis of rotation passes through its centre and draw the necessary figures. [10]
(b) A flat circular disc of mass 0.05 kg and diameter 0.02 m rolls on its edge on a smooth horizontal surface with a velocity of 0.05 m/s. Calculate its total kinetic energy. [10]
4. (a) State and explain Brewster's law. Using Brewster's law, prove that the reflected and refracted rays are at right angles to each other. [10]
(b) A thin equiconvex lens of focal length 4 meters and refractive index 1.5 rests on and in contact with an optical flat and using light of wavelength 5460 \AA . Newton's rings are viewed normally by reflection. What is the diameter of the 5th bright ring? [10]