

The University of Asia Pacific
Department of Civil and Environmental Engineering
Final Examination Spring 2004

Course # CEE-101
 Full Marks: 70 (= 7 × 10)

Course Title: Engineering Mechanics - I
 Time: 2 hours

[Answer any 7 (seven) of the following 10 questions]

1. In the following figure, the resultant (R) of the forces acts vertically. Calculate the magnitude of N and R.

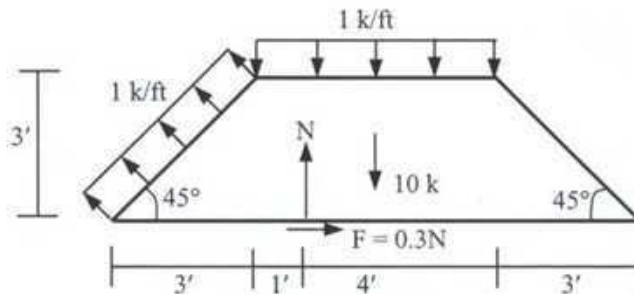

2. For of the force system described in Problem 1, the resultant (R) acts horizontally. Calculate the magnitude and location of R.
3. In the truss shown below, calculate the reactions at supports A and D and forces in members BC, CG and EF.

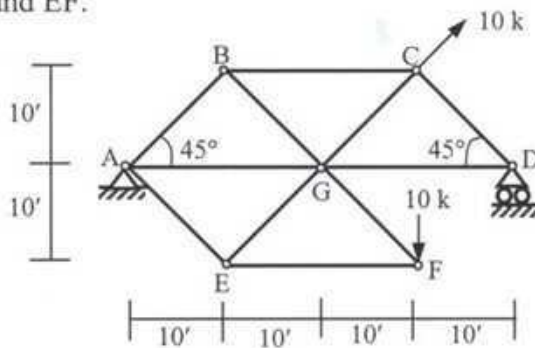

4. In the structure shown below, calculate the force in cable EF, member BG and the bending moment at C.

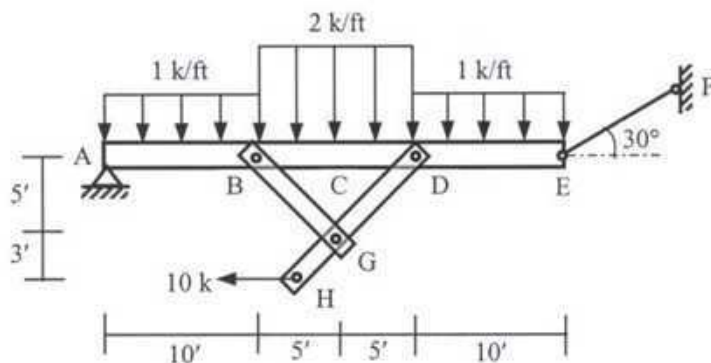

5. Locate the centroid of the shaded area shown in the figure below.

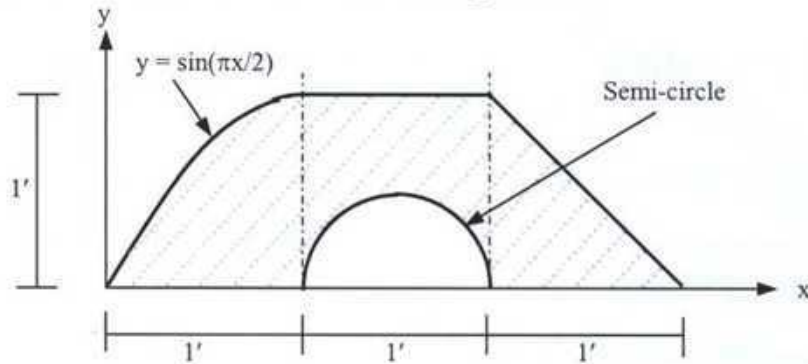

6. Locate the centroid of the volume generated by revolving about x axis the shaded area shown in Problem 5.
7. For the shaded area described in Problem 5, calculate moment of inertia about x axis.
8. For the shaded area shown in the figure below, calculate the moment of inertia about x axis.

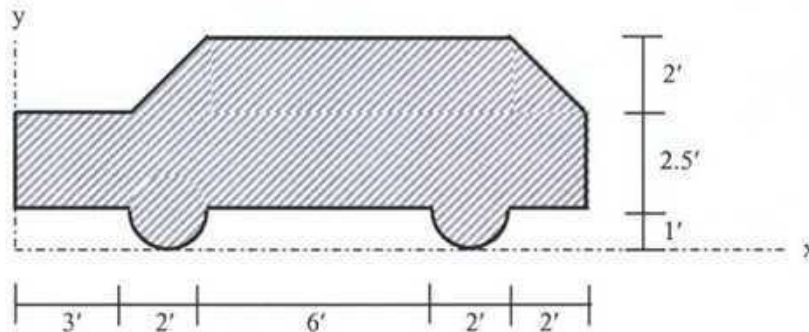

9. The location of centroid for the shaded section shown in Problem 8 is given by $\bar{x} = 8.02'$, $\bar{y} = 2.88'$, while centroidal moments of inertia are $\bar{I}_x = 105.71 \text{ ft}^4$, $\bar{I}_y = 952.58 \text{ ft}^4$. Calculate the minimum moment of inertia of the section and show the corresponding principal axis.
10. The figure below shows cable ACB which weighs 1 lb/ft and is subjected to a horizontal tension of 100 lb. Calculate y_1 , y_2 , total length of cable and maximum tension in the cable assuming it to be a (i) parabola, (ii) catenary.

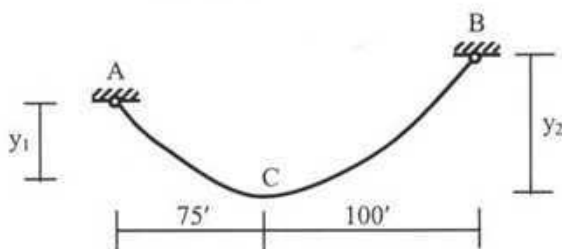

The University of Asia Pacific
Department of Civil and Environmental Engineering
Final Examination Spring 2004

Course # CEE-103
 Full Marks: 70 (= 7 × 10)

Course Title: Engineering Mechanics - II
 Time: 2 hours

[Answer any 7 (seven) of the following 10 questions]

1. A signboard H weighing ($W =$) 200 lb and supported as shown below is subjected to wind load ($F =$) 500 lb perpendicular to its surface. Calculate the forces in members EF, BG and the support reactions A_x , A_y and A_z .

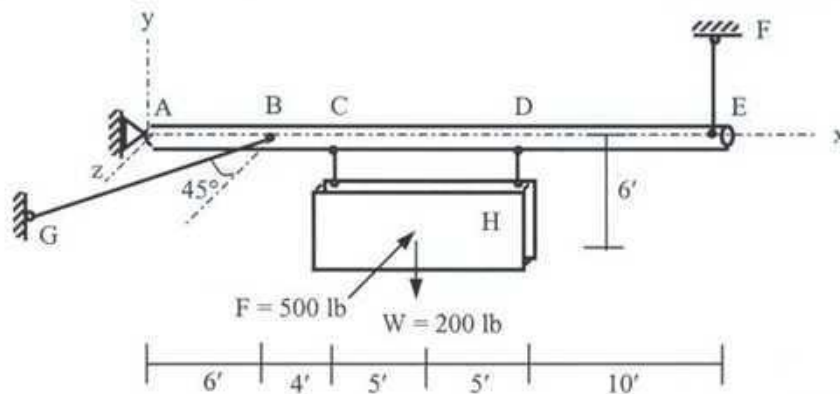

2. The shaded area shown below is revolved around the x-axis. Calculate the mass moment of inertia about x-axis of the solid generated [unit weight of the material = 50 lb/ft³].

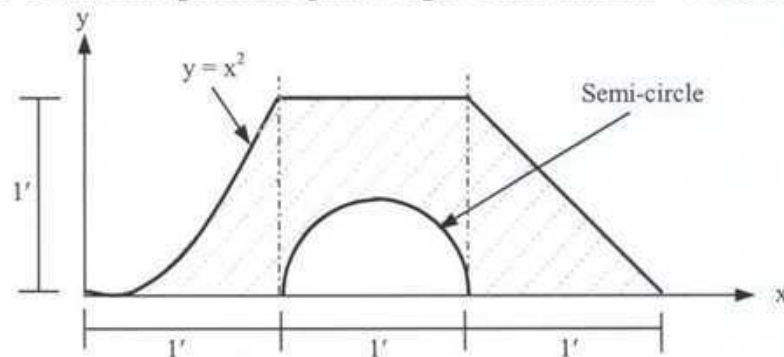

3. The figure below shows a box A (weighing $W_A =$ 100 lb) being pulled up by a force P along an inclined plane with $f_s = 0.30$ and $f_k = 0.20$. Calculate the magnitude and direction of the frictional force F if (i) $P = 0$, (ii) $P = 25$ lb, (iii) $P = 75$ lb and (iv) $P = 100$ lb.

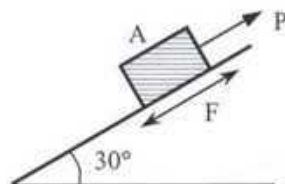

$$f_s = 0.30$$

$$f_k = 0.20$$

4. A particle rotates along a circular path $x^2 + y^2 = 4$ with an angular acceleration $\alpha_t = \sqrt{\omega}$, where ω is the angular velocity. If the particle starts with $\omega_i = 4$ rad/sec, calculate its angular velocity, tangential and normal acceleration after traversing a distance 10 ft along the circle.

5. The figure below shows a box A (weighing $W_A = 100$ lb) being pulled up by a force P over a pulley B (with $f_s = 0.30$, $f_k = 0.20$) along a smooth inclined plane. Calculate the magnitude and direction of the acceleration of A if (i) $P = 0$, (ii) $P = 25$ lb and (iii) $P = 100$ lb.

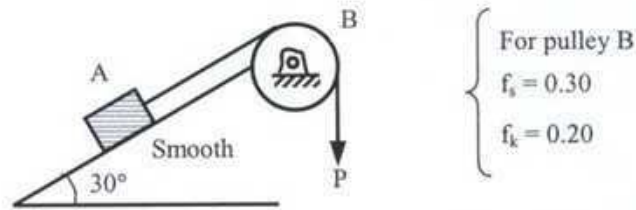

6. In the figure below, G is the centroid of a car that weighs 3000 lb and is supported on front wheels A and back wheels B. As the car moves forward, calculate its allowable acceleration and deceleration and the corresponding values of P if the maximum allowable vertical force on A and B is 2500 lb ($f_k = 0.20$).

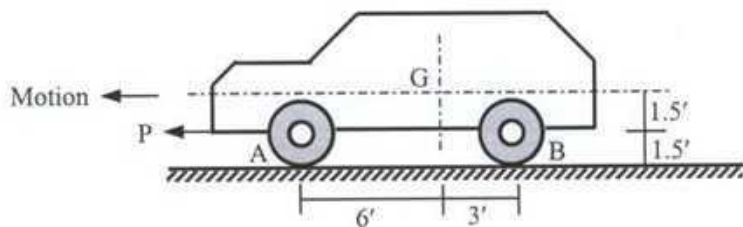

7. The figures below show a box A ($W_A = 100$ lb) being pulled by a force P ($= 100$ lb) over a horizontal surface with $f_k = 0.20$. Calculate the velocity of the box after traveling 10 ft (i) without wheel, (ii) with four cylindrical wheels weighing 5 lb each having 2' diameter.

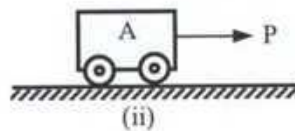
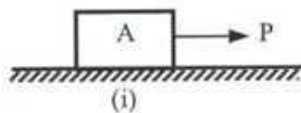

8. The figure below shows a box B supported by a spring and cable over a smooth cylindrical pulley A. If weight of A is $W_A = 100$ lb, weight of B is $W_B = 100$ lb and spring constant is $k = 100$ lb/ft, calculate the maximum distance traveled by B and its maximum velocity.

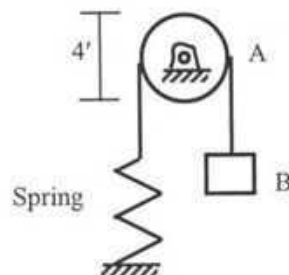

9. The figure below shows a falling plate P being kept in equilibrium at a height 100 ft from ground by a jet of water (of area $A = 2 \text{ in}^2$) flowing upward. If the water jet is discharged with an initial upward velocity of $u_w = 100 \text{ ft/sec}$, calculate the weight of the plate [unit weight of water = 62.5 lb/ft^3].

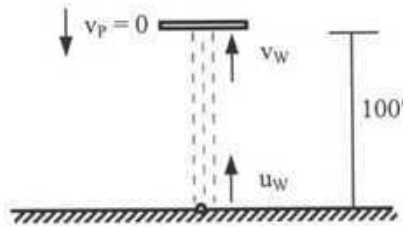

10. The figure below shows a billiard game, where the white ball A (weight $W_A = 0.50 \text{ lb}$, initial velocity u_A) hits a black ball B (weight $W_B = 0.50 \text{ lb}$), which is initially at rest. If the coefficient of restitution $e = 0.8$, calculate the magnitude and direction of the initial velocity of A (u_A) if it has the final velocity (v_A) as shown. Also calculate the final velocity of B (v_B).

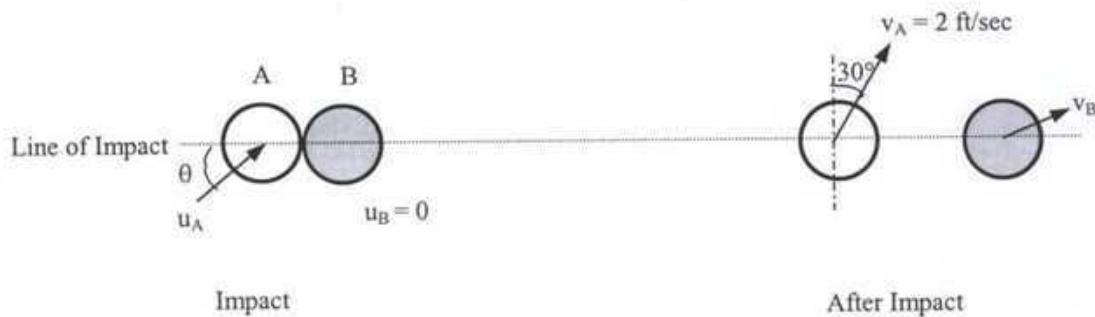

The University of Asia Pacific
Department of Civil and Environmental Engineering
Final Examination: Spring 2000

Course Number: CEE 201
Course Title: Engineering Materials
Semester: Spring 2004

Time: 3 Hours
Full Marks: 100

There are **EIGHT** questions in this question paper. Answer any **SIX** questions.

Question 1

- (a) Define engineering material. To select an engineering material what factors to be considered? 3
- (b) Draw qualitative stress-strain curves for (i) perfectly elastic material, (ii) perfectly elasto-plastic material, (iii) concrete, and (iv) steel. 4
- (c) Write the constituents of brick clay and explain their functions. 5
- (d) At what temperature bricks are burned? Why such a temperature is maintained? What will happen if the burning temperature is below or above this standard temperature? 4 $\frac{2}{3}$

Question 2

- (a) Write the mineral constituents of Portland cement. 2
- (b) Explain hydration process of aluminates and silicates of cement. Why gypsum is added with cement? What will happen if more gypsum is added? 6 $\frac{2}{3}$
- (c) Define low heat cement, quick setting cement, and sulfate resisting cement. 3
- (d) Why Vicat's apparatus is used? Find out the initial setting time from the following data: 5

Time (min)	Penetration of the 1 mm needle (mm)
10	>40
20	>40
30	>40
40	>40
50	32.5
60	30
70	27.5
90	22.5

Question 3

(a) Explain bulking of sand. Explain the importance of bulking of sand in volume measurement.

2

(b) Explain the physical meaning of 1 inch and #50 sieves. Write the standard sieves with their opening sizes.

2

(c) How do you decide the maximum aggregate size of a concrete member?

1

(d) Calculate the FM of the following aggregate samples:

11
3

ASTM Sieve	Amount Retained (g)	
	Sample 1	Sample 2
3 inch	0	100
1.5 inch	0	100
¾ inch	0	100
3/8 inch	0	200
#4	0	0
#8	40	0
#16	40	0
#30	55	0
#50	55	0
#100	30	0
#200	20	0
Pan	10	0

Draw the grading curves for the samples. Make comments on the grading curves.

Question 4

(a) Write the functions of sand, cement, water, and gravels in concrete.

3

(b) Write the necessary qualities of sand and gravel used for concrete.

2

(c) What will happen if you use seawater as mixing water?

2

(d) Why concrete is used whole over the world?

2

(e) Why cube strength of concrete is higher than the cylinder strength of the same mix?

2

(f) Explain the hydration of cement for a fine cement and coarse cement.

2

(g) Explain the development of strength of concrete with time for air curing, curing under water for 7 days, and curing under water for 14 days, and continuous curing under water.

3
3

Question 5

(a) Explain why 28-day compressive strength is not necessarily confirmed the durability of concrete?

2

(b) How you measure workability of concrete? What will happen if workability of concrete is very low?

2

(c) Write the factors affecting the workability of concrete.

2

(d) Calculate the unit content of sand, gravel, and water for the following mix design conditions:

10
3

W/C=0.45

Volume ratio of sand to aggregate = 0.42

Unit content of cement = 300 kg/m³

Air content = 5%

Unit weight of cement = 3100 kg/m³

Unit weight of water = 1000 kg/m³

Unit weight of sand = 2650 kg/m³

Unit weight of gravel = 2600 kg/m³

Calculate the amount of cement, water, sand, and gravels for 100 cubic meters of concrete.

What is the unit weight of the concrete based on the proposed mixture proportion?

Question 6

a) You are assigned for supervision of a bridge construction project. How will you make a good quality concrete keeping in mind 28-day strength requirement and durability requirement?

3

(b) Define plastic shrinkage, drying shrinkage, carbonation shrinkage, and autogenous shrinkage of concrete.

2

(c) Explain the quality of water for mixing and curing of concrete.

1

(d) Define creep of concrete. Draw qualitative strain versus age curve showing instantaneous strain, creep strain, instantaneous recovery, and creep recovery.

2

(e) What is segregation and bleeding of concrete? How do you control these?

2

(b) Explain seawater attack of concrete.

6
3

Question 7

(a) Why steel bars in concrete are corroded? How you can prevent it?

3
3

(b) Why spalling of cover concrete is occurred due to the corrosion of steel bars in concrete?

1

(c) Write short notes on paints and varnishes.

2

(d) Define polymerization.

1

(e) How natural rubber is made? Define vulcanization. Write the properties of natural rubber.

3

(f) Write short note on high performance concrete, lightweight concrete, and underwater concrete.

6

Question 8

(a) Write short note on ferrocement?

1
3

(b) Explain crystalline and amorphous materials.

2

(c) Define atomic packing factor? Calculate atomic packing factor for plain cubic unit cell, body centered cubic unit cell, and face centered cubic unit cell.

5

(d) Draw a section of an exogenous tree and level its components. How annual rings are formed? What are the differences between sapwood and heartwood?

3

(e) Why seasoning of timber is important? What will happen if timber is not seasoned before use? How moisture content of timber affects the compressive strength of timber?

3

(f) Write the field tests of bricks. How you will check the efflorescence of a brick?

The University of Asia Pacific
Department of Civil and Environmental Engineering
Final Examination, Spring 2004

Course # CEE 211
 Full Marks: 100

Course Title: Mechanics of Solids I

Time: 3 hrs

There are two sets in the question paper namely "PART A" and "PART B". You have to answer from both sets according to the instruction mentioned on each set.

PART A

Total Marks: $10 \times 4 = 40$

*There are **SIX** questions in this part. Answer any **FOUR**.*

- Q1. The structure shown in figure is supporting a 3-k/ft Masonry work and a 1 ft dia-3 ft height concrete cylinder. Find out the reactions at support A and cable BC. Also calculate the axial force, shear force and bending moment at section a-a. (unit weight of concrete is 0.15 k/ft^3 .) Assume negligible weight of the structure. (10)

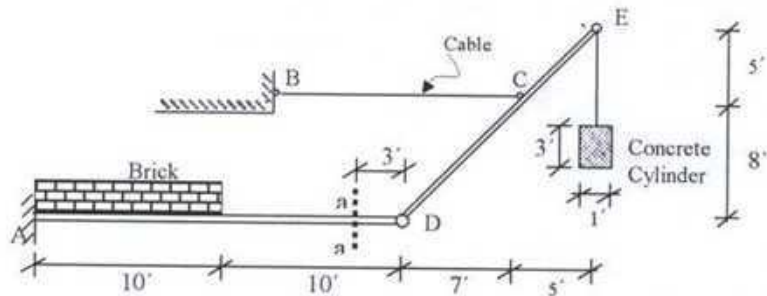

- Q2. (a) Two concrete cylinders having same dimensions (1ft diameter-3ft height) as the cylinder in Q.1 are supported by two frictionless pulleys at C and D. Calculate the reactions at support A and B. (4)

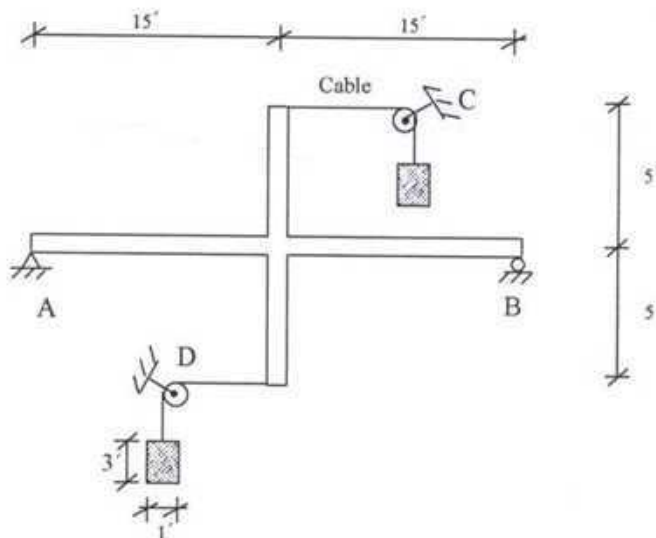

- (b) Consider a curved beam whose centroidal axis is bent into a semicircle of 15-in radius as shown in figure. If the member is being pulled by 2000 lb forces, find the axial force, shear force and bending moment at section a-a. (6)

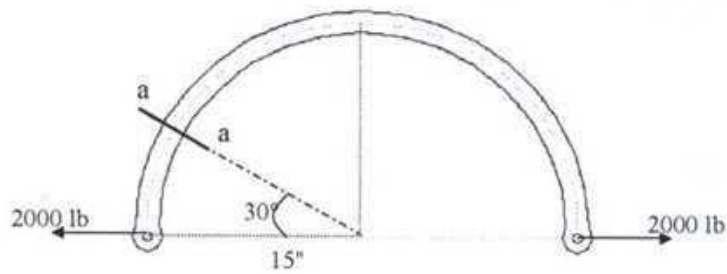

- Q3. A small narrow barge is loaded as shown in figure. Plot the shear and moment diagram for the applied loading. (10)

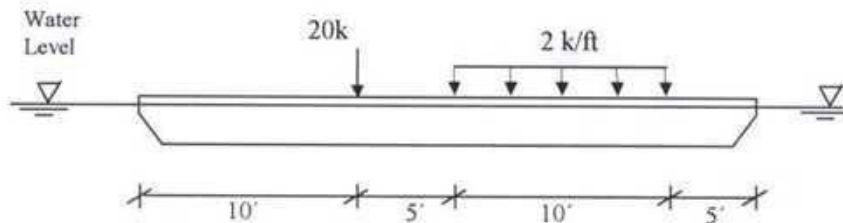

- Q4. Draw SFD and BMD for the following structure. (10)

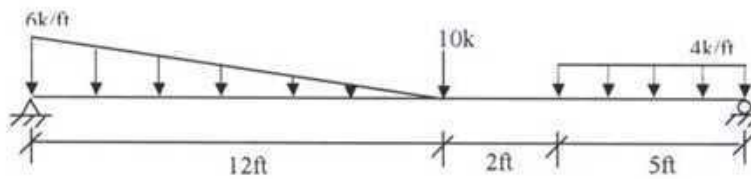

- Q5. Draw AFD, SFD and BMD for the following structure. (10)

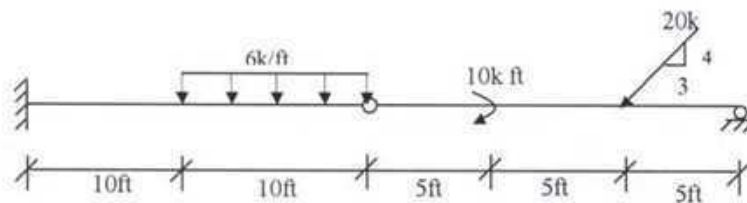

- Q6. Consider the idealized dynamic system shown in figure. The shaft AB rotates at a constant angular velocity of 500 rpm. A light rod CD is attached to this shaft at point C and at the end of this rod a 6-inch diameter steel sphere is fastened. The sphere at D spins the complete circle on a frictionless plane. Select the size of the rod CD. Given: Ultimate strength of the rod material is 60000 psi, FS= 3 and unit weight of steel is 490lb/ft³. (10)

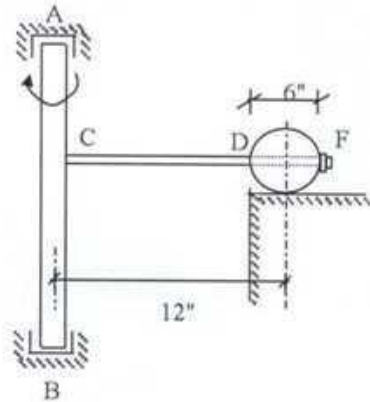

PART B

Total Marks: 5 x 12= 60

There are EIGHT questions in this part. Answer any FIVE.

- Q7. A 40-inch long aluminum rod is enclosed within a steel-alloy tube. The two materials are bonded together. If the stress-strain diagrams for the two materials can be idealized as shown in figure, what end deflection will occur for load $P=180$ kips? The x-section of the rod is shown in figure. (12)

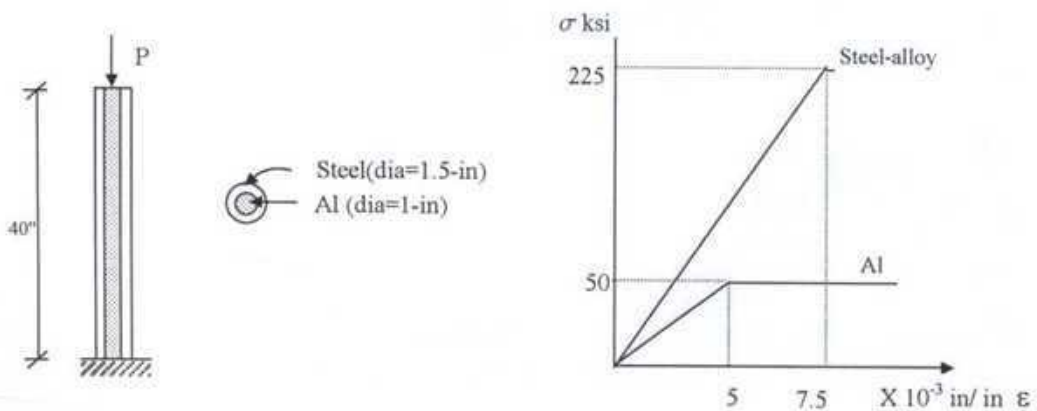

- Q8. (a) A 4-in cube of steel is subjected to uniform pressure of 40,000 psi acting on all faces. Determine the change in dimension between two parallel faces of the cube. Let $E=30 \times 10^6$ psi and $\nu = 1/4$. (5)

- (b) Two bars made of linearly elastic material whose proportions are shown in figure are to absorb the same amount of energy delivered by axial forces. Compare the maximum stresses in the two bars caused by the same input of energy. (7)

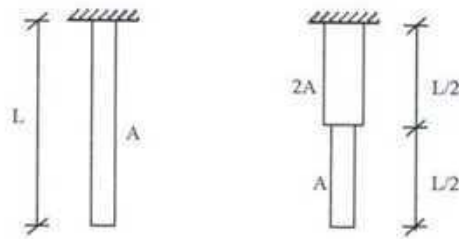

- Q9. Compare stresses in a 4-in.-by-4-in. rectangular bar subjected to end couples of 15000 in-lb in the two special cases: (12)

(a) Straight beam

(b) Beam curved to a radius of 14 in. along the centroidal axis.

Show the stress distribution diagram for each case.

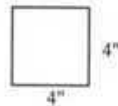

- Q10. A 2-ft diameter steel sphere is suspended at the free end of a 10-ft long weightless cantilever as shown in figure. The beam has a composite cross-sectional dimension shown in figure. The upper 5-in.-by-1-in. part is steel and bottom 5-in.-by-9-in. part is wood. What are the maximum stresses in wood and steel at the support? (12)
Given: Unit wt of steel is 490 lb/ft^3 , $E_s = 30 \times 10^6 \text{ psi}$ and $E_w = 1.5 \times 10^6 \text{ psi}$

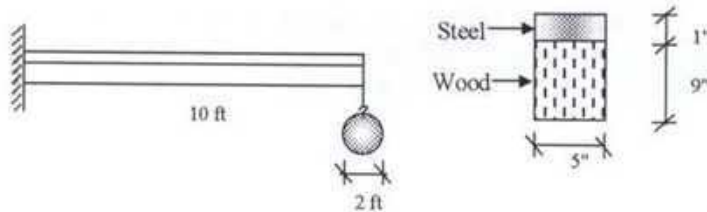

- Q11. (a) Two long wooden planks form a T section of a beam as shown in figure (i). (12)
If this beam transmits a constant vertical shear of 500lb, find the necessary spacing of the nails between the two planks to make the beam act as a unit. Assume that allowable shearing force per nail is 150 lb.
(b) Calculate the shear stresses that develop at section 1-1 for the T-beam section as shown in figure (ii). This beam transmits the same vertical force as the previous one.

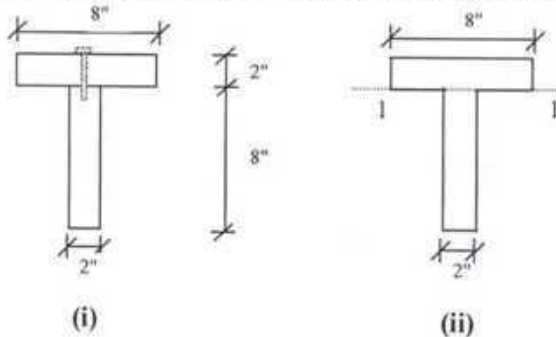

- Q12. A wooden reservoir of 10-ft diameter consists of $2 \times 4/3$ " steel hoops spaced at 12-c/c. The 20 ft reservoir is full of water. Find out the maximum stress in hoop. If the reservoir contains salt water having specific gravity 1.2, what will be the spacing of hoops so that the maximum stress in hoop does not change? (12)

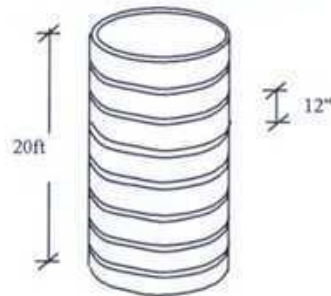

- Q13. A plate is connected with a gusset plate by 4-25 mm ($A=491 \text{ mm}^2$) rivets. The layout is as shown in figure. Calculate maximum shear stress in the rivet that will develop if the plate is subjected to an inclined force of 100KN. (12)

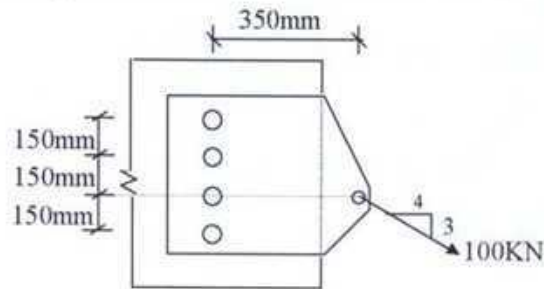

- Q14. Find the lengths of weld L_1 and L_2 required to attach a $L-76 \times 51 \times 11.1$ ($A=1290 \text{ mm}^2$) angle to a machine as shown in figure, so that the connection develops a tensile stress of 200 MPa in the angle. Use E70 Electrodes (Tensile strength = 483 MPa) and 10-mm weld. (12)

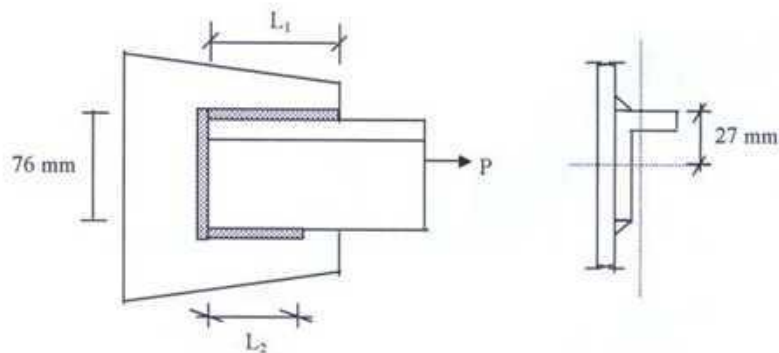

5 copies (set)
↓
25

The University of Asia Pacific
Department of Civil and Environmental Engineering
Final Examination, Spring'2004

Course No # CEE 311 Course Title: Structural Analysis and Design I

Full Marks: 180

Time: 3 hrs

There are two sets in the question paper namely "PART A" and "PART B". You have to answer from both parts according to the instruction mentioned in each part.

PART A

Total Marks: 20x4=80

There are SIX questions in this part. Answer any FOUR.

1. Derive 'General Cable Theorem'.
2. Draw the shear force and bending moment diagrams of the following structure,

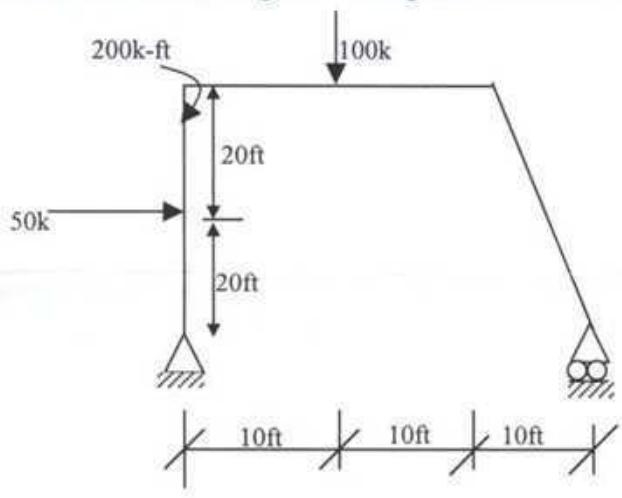

3. Draw the shear and moment diagrams for the structure shown in the figure below

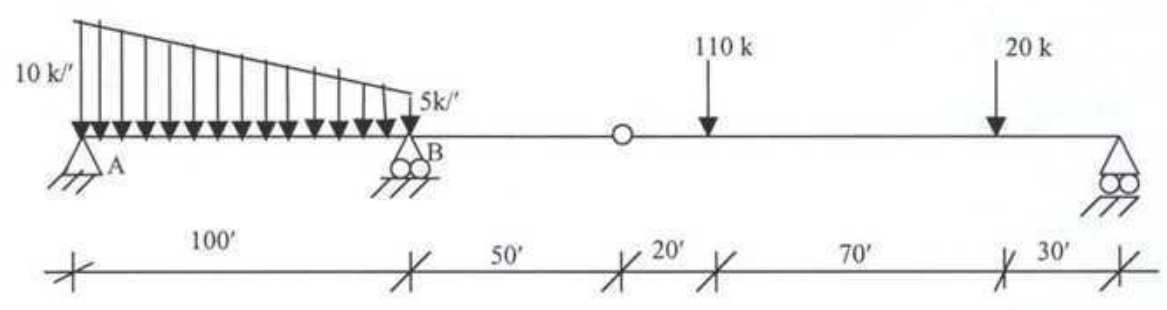

4. Calculate the forces in bars "a" and "b",

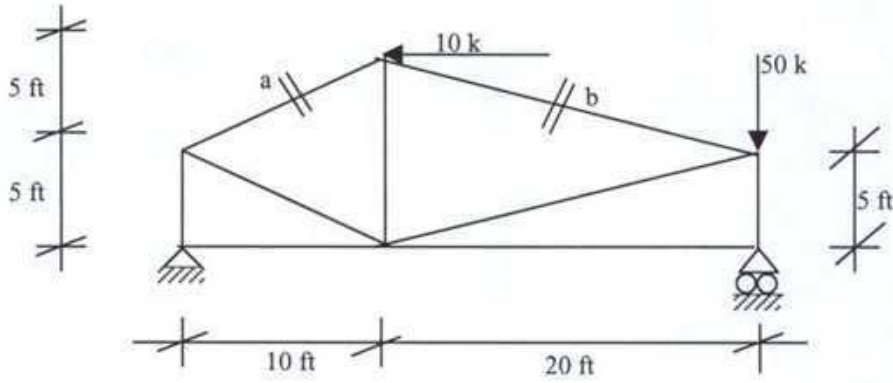

5. In the statically determinate suspension bridge shown in figure below, determine the maximum cable tension and the force in bar "a" of the stiffening truss.

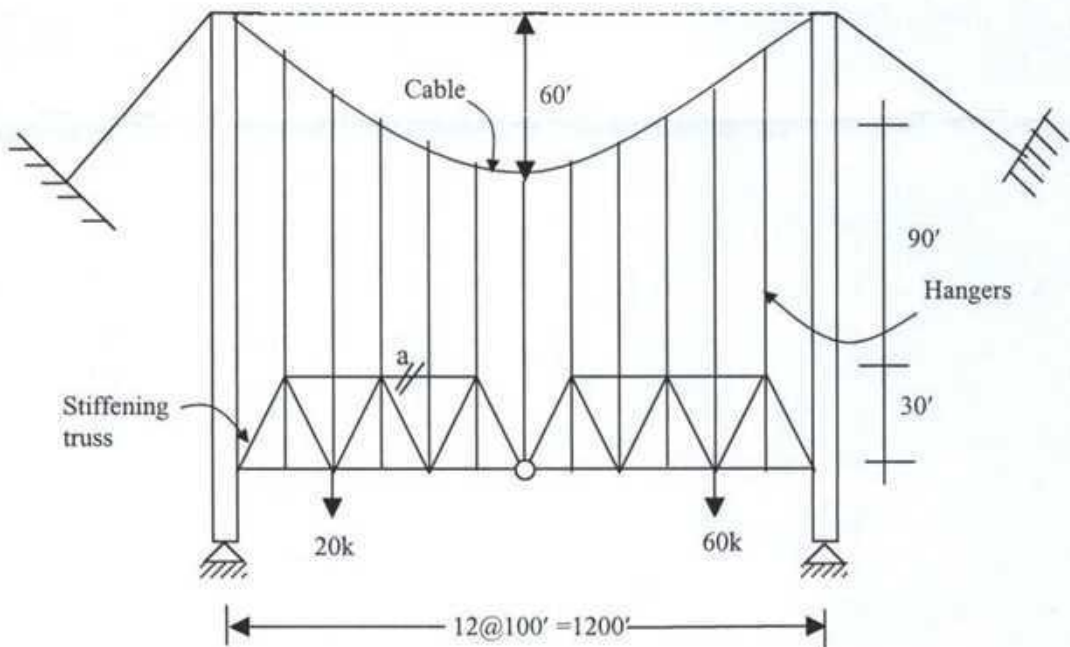

6. Determine the reactions at the support A and B of the three-hinge arch shown in the figure below.

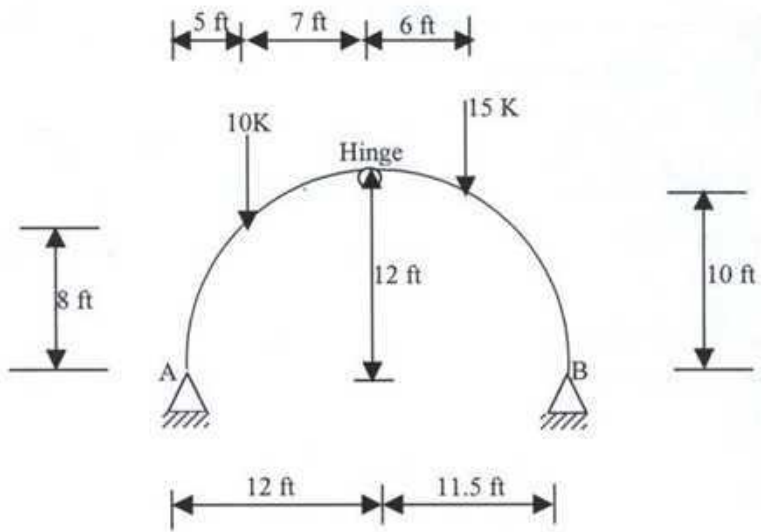

SET B

Total Marks: 20x5=100

There are **SEVEN** questions in this set. Answer any **FIVE**.

7. Draw influence lines for (i) axial force at H, (ii) shear force at D and (iii) bending moment at D of the frame shown in Figure below. Load moves from A to E.

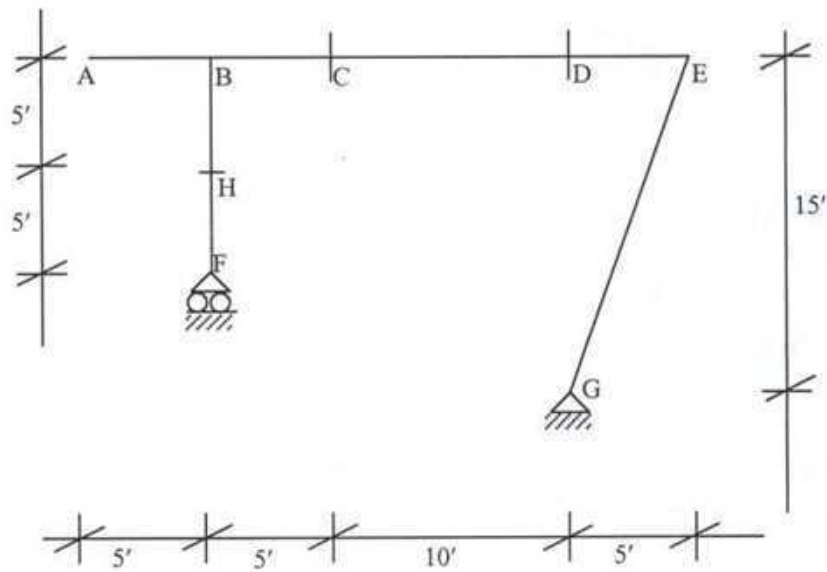

8. Draw influence line diagrams for forces in members A, B and C of the truss shown in the figure below. Unit load moves from X to Y.

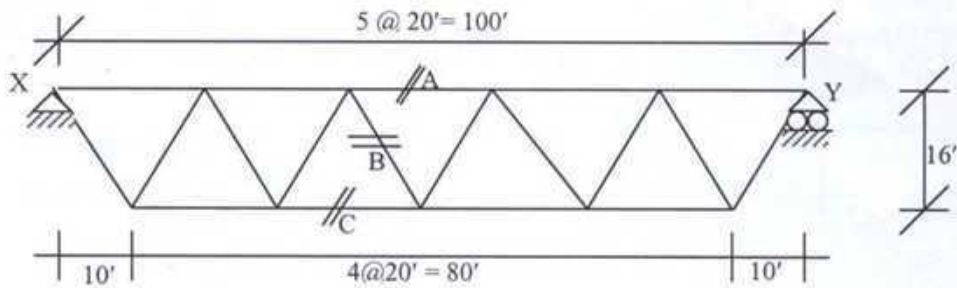

9. The girder AB supports a floor system as shown in Figure below. Draw influence line diagrams for shear at panel 2-4, bending moment at panel point 2 and floor beam reaction at panel point 4. Load moves from 1 to 6.

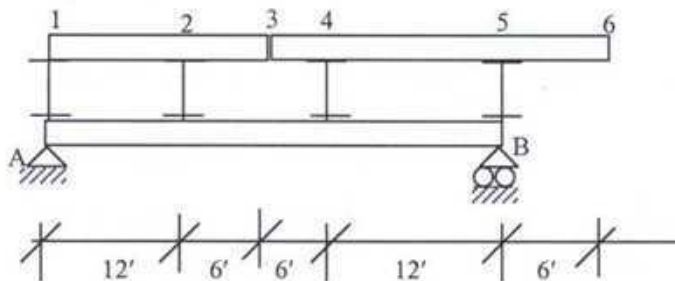

10. Calculate the following in the beam of the figure below due to a moving uniform load of $5 \text{ k}'$ and roving concentrated load of 40 k .
- 1) Maximum shear just to the left of support A.
 - 2) Maximum shear just to the right of support A.

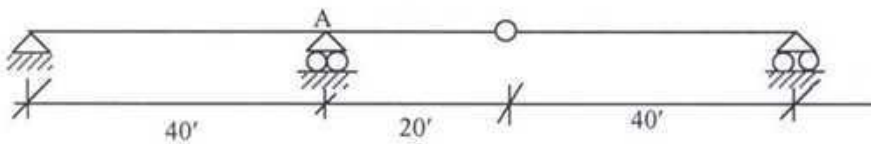

11. Determine the maximum bending moment at C, a section 30 ft from the left support of a 70 ft span simply supported beam, due to the series of moving loads shown in figure below.

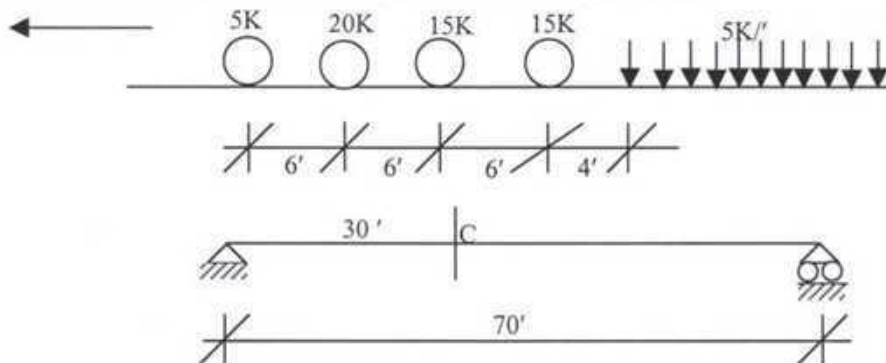

12. Due to the loads shown in the figure below, calculate the maximum shear at the quarter point C from the left support of the deck girder shown in the figure.

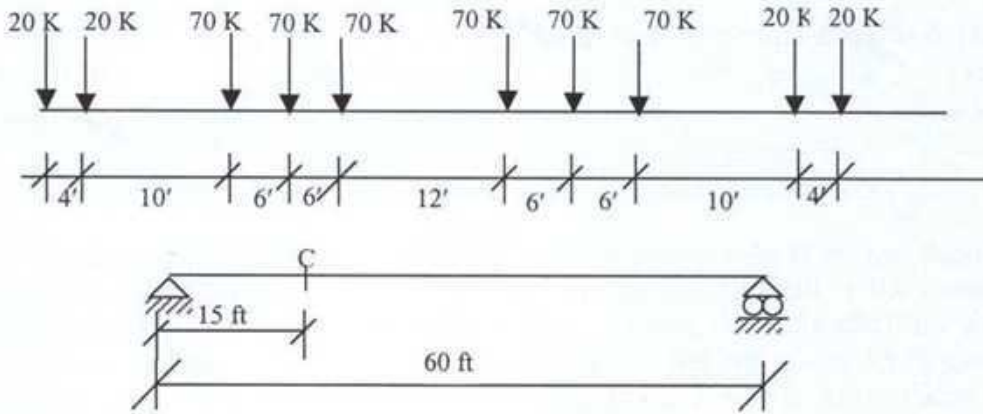

13. Calculate the maximum reaction at support A of a deck girder ABC due to the loads as shown in the figure below

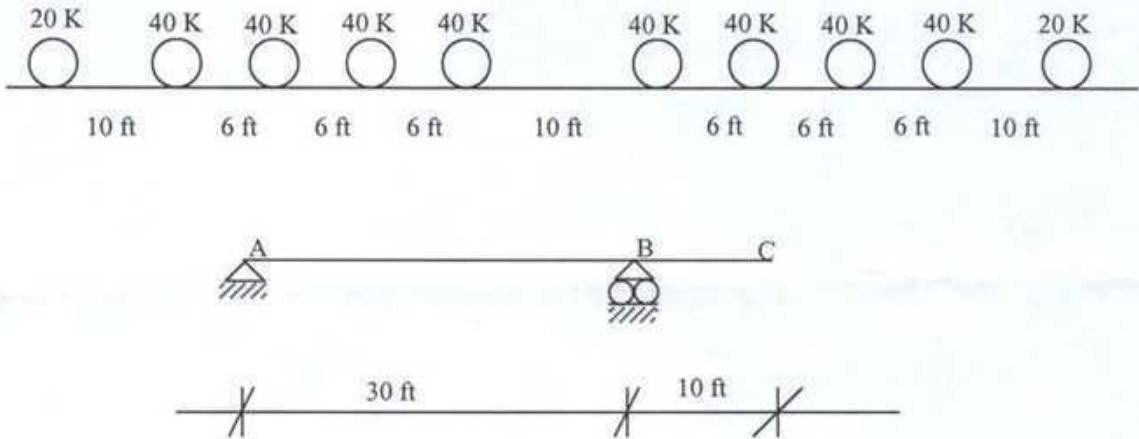

2.

In addition to the external load, the hinge support of the following frame settles down an amount of $70/EI$. Draw the bending moment diagram for the frame.

16 2/3

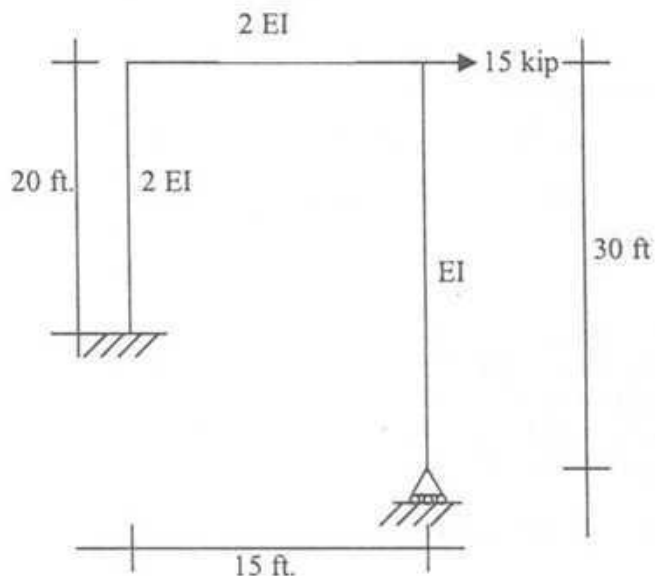

3.

Using portal method, Draw BMD for the exterior column D of the interior frame (along the wind load direction). Wind load distribution is shown in the figure.

16 2/3

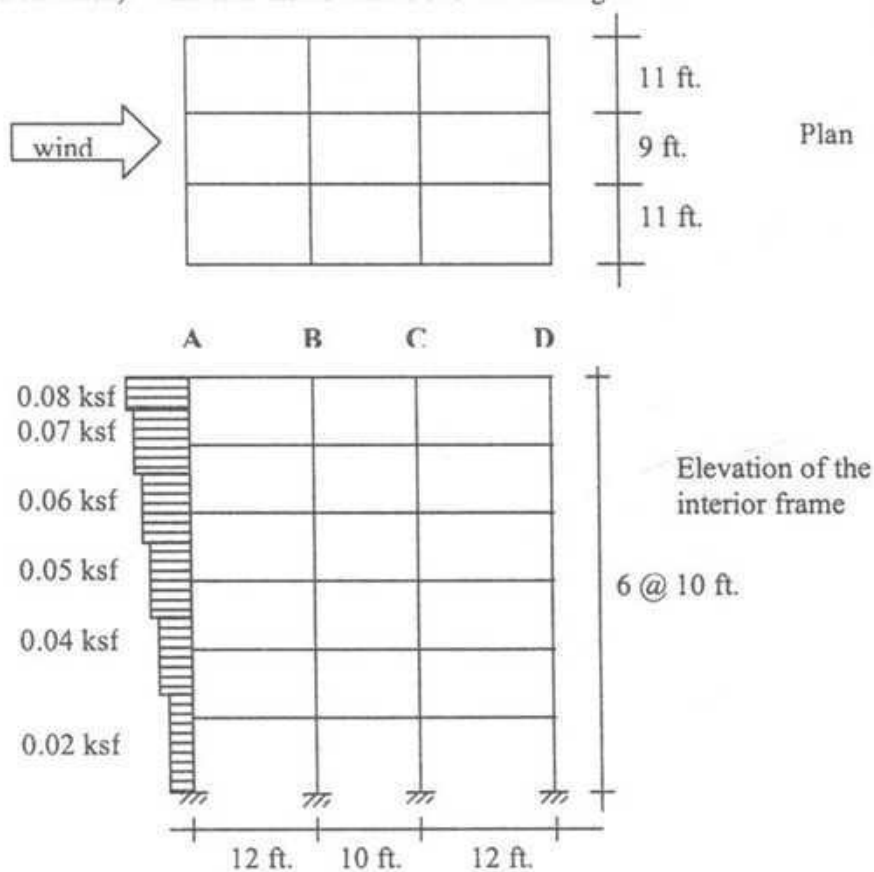

2/5

4(a)

Draw AFD, SFD and BMD for the portal frame shown below. [Use approximate method]

8 1/3

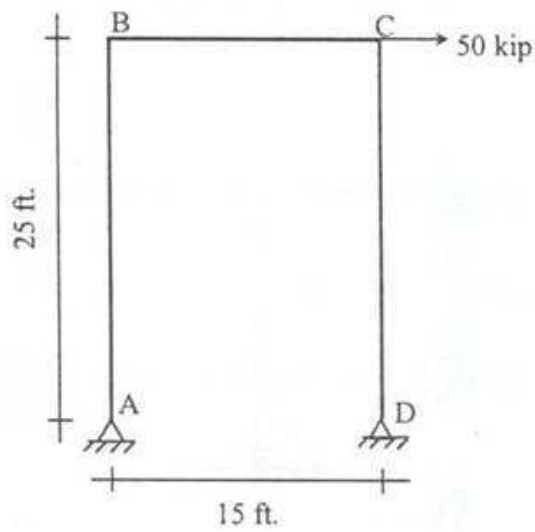

4(b)

Find the forces in the members of the truss marked by double stripes. [Use the assumption that diagonals can carry tension only]

8 1/3

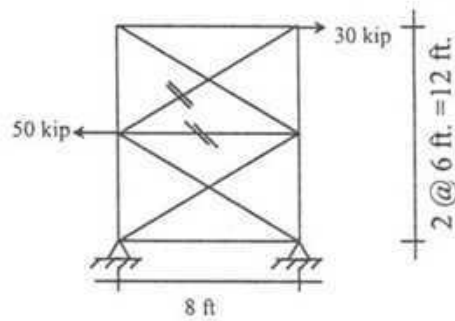

3/5

5.

Using Cantilever method draw (a) AFD of the column indicated by the down arrow.
 (b) BMD for the same column.

for the frame shown below.

[Relative cross-sectional area for each column is given below]

16 2/3

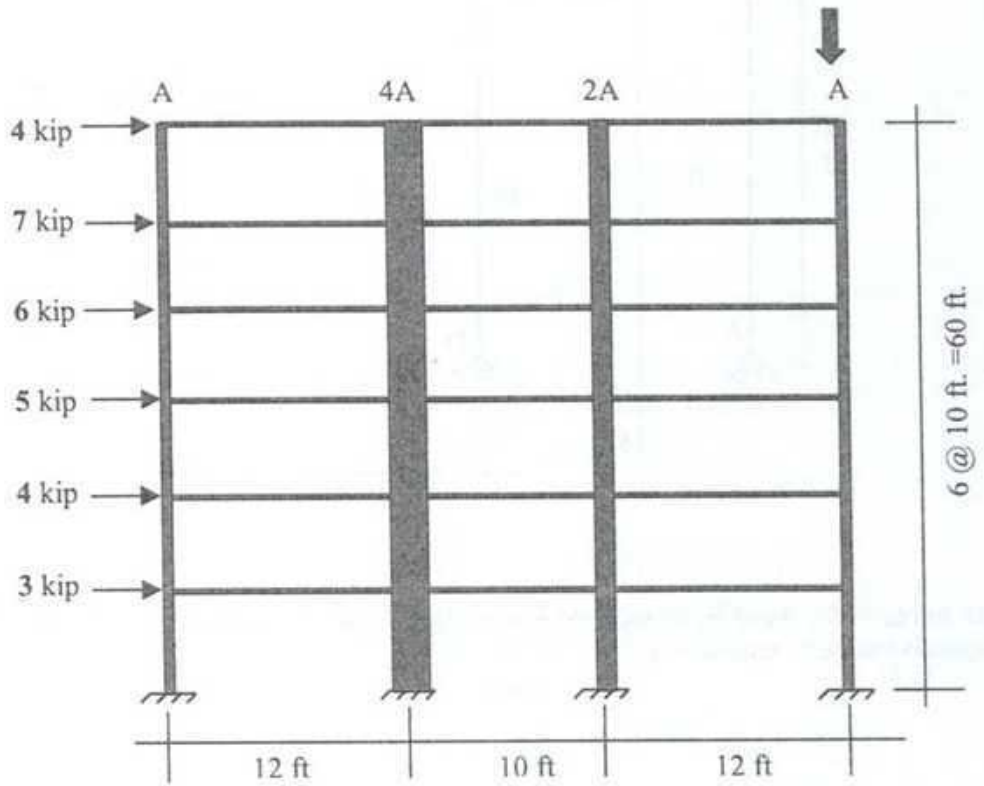

6(a)

Determine the vertical deflection of the joint B of the truss shown below. [Areas (in.^2) of the members are shown in the circles.]

8 1/3

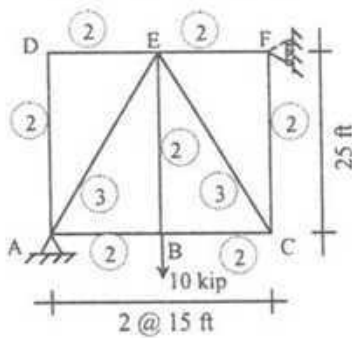

6(b)

Find the shear forces at the base of the foundations.

8 1/3

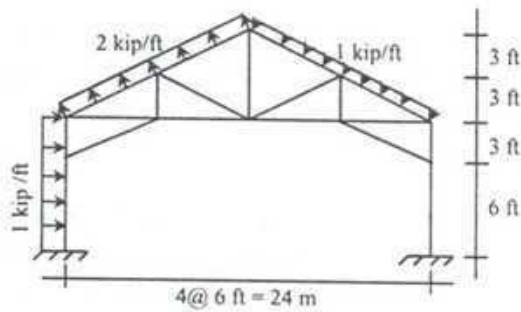

7.

Using the method of consistent deformation, draw the bending moment diagram for the beam. Consider the effect of both axial force and bending.

[Cross sectional area of beam, $A = 150 \text{ in}^2$, Moment of inertia, $I = 2812.5 \text{ in}^4$, Modulus of elasticity of the beam material, $E = 5000 \text{ ksi}$]

16 2/3

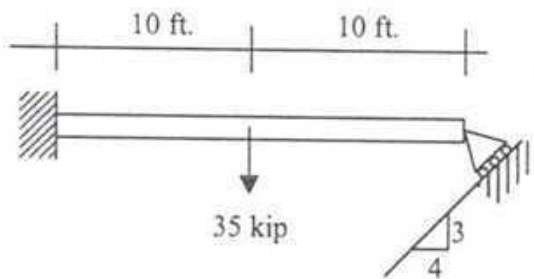

8.

For the space truss shown in the following figure, all the vertical and horizontal members are of same length, S . Vertical force Q acts at point L . Horizontal force R acts at K along KJ member. Another Horizontal force P acts at E making a 60° angle with member EH . Determine all the member forces.

16 2/3

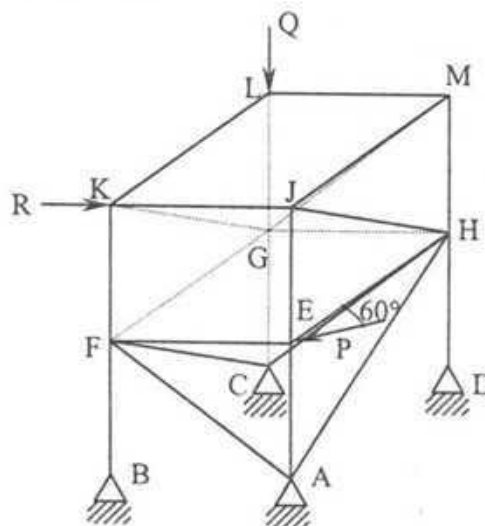

5/5

THE UNIVERSITY OF ASIA PACIFIC
CEE315 (Reinforced Concrete)
Department of Civil Engineering

Term : Final Examination (August 2004)

Full Marks-100

Time: 3 hours

SECTION-A (Answer all the questions)

28

1. What do you mean by singly reinforced, doubly reinforced and T-beams in RC construction. Discuss with sketches. 6
2. Do you think addition of bars in the compression zone of a singly reinforced beam will always increase the moment capacity of that particular section? Justify your answer. 6
3. Discuss temperature and shrinkage reinforcements and mention their importance in RC slabs. 6
4. Mention the recommendations to fix the effective width of the T-beam according to ACI. 5
5. Why do you use yield strength not the ultimate strength of reinforcing steel in Ultimate Strength Design (USD) method for RC elements. 5

SECTION-B (There are 7 questions, Answer any 6)

6×12=72

6. A beam with a cross section of 12 in. × 30 in. (Fig. 1) is subjected to a working DL of 1.8^k/ft. including self wt. and a working LL of 1.3^k/ft. Span of beam = 24 ft.
 - i) Design the beam by ASD
 - ii) Design the beam by USD
 - iii) Give your comments on the designs.

Given $f_c = 3$ ksi; $f_y = 50$ ksi; $f_s = 20$ ksi; $n=9$; $k = 0.378$; $j = 0.874$; $R = 223$

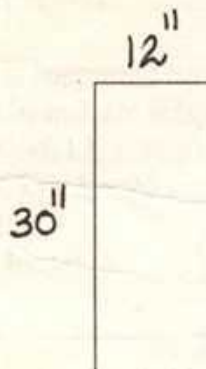

Fig. 1

7. A floor slab, 5 inch thick, is supported by simply supported beams having span of 32 ft. and spaced 11 ft. c/c is shown in Fig. 2. The beams are reinforced with 8 nos. # 9 bars as shown. Compute design moment for a beam and then determine the allowable live load on the slab. FF = 20 psf; Random Wall Loads = 30 psf. Given $f'_c = 3$ ksi; $f_y = 50$ ksi; $f_s = 20$ ksi; $n=9$; $k = 0.378$; $j = 0.874$; $R = 223$.
USE EITHER WSD OR USD,

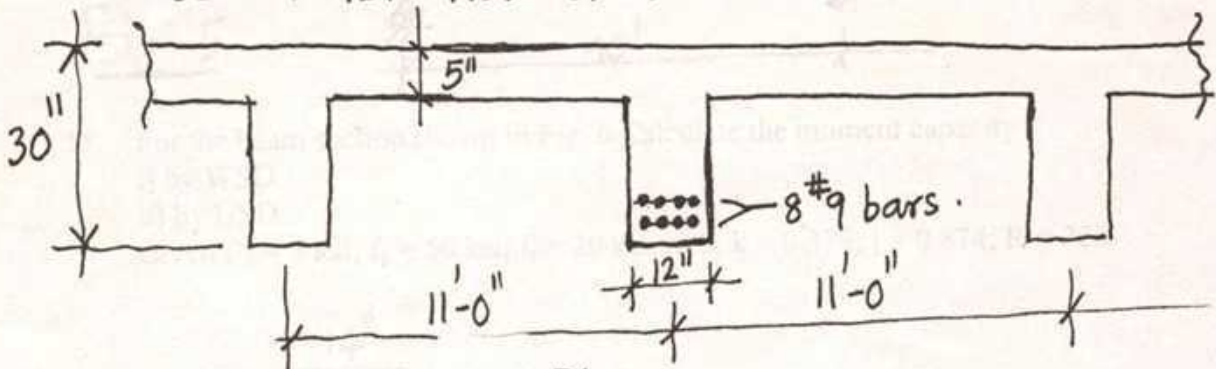

Fig. 2

8. A 6 in. thick slab (one way) is supported on RC beams as shown in Fig. 3. The calculated total dead load on the slab is 100 lbs/sft and the slab is subjected to a working live load of 80 psf. The live load can occupy any portion or any position on the slab. Calculate the critical design moments and show the necessary reinforcements in sketches. Use either WSD or USD. Given $f'_c = 3$ ksi; $f_y = 50$ ksi; $f_s = 20$ ksi; $n=9$; $k = 0.378$; $j = 0.874$; $R = 223$

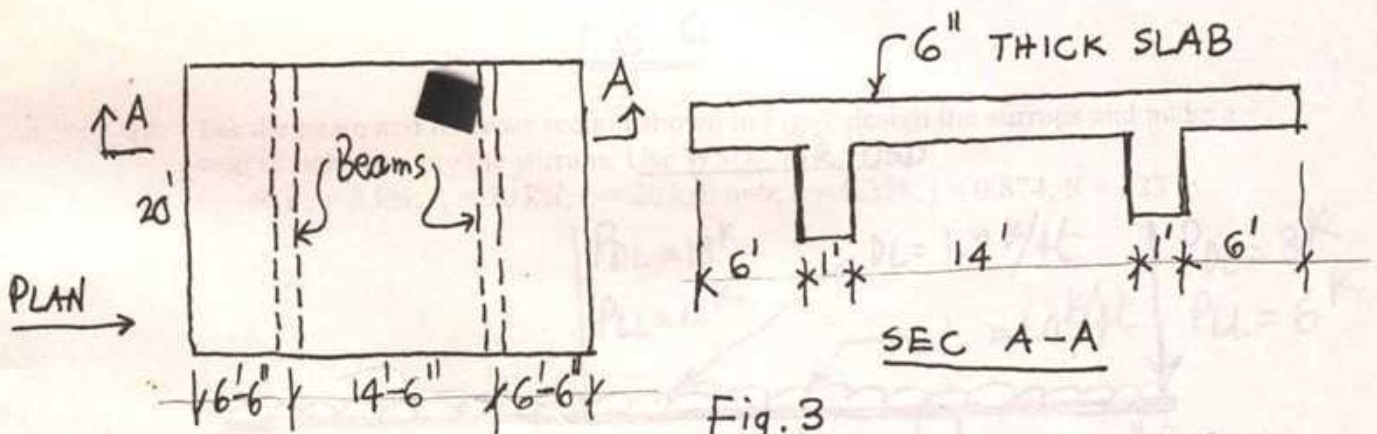

Fig. 3

9. A floor slab 4 in. thick is supported by reinforced concrete beams spaced 10 ft. c/c as shown in Fig 4. The beams are simply supported over a span of 30 ft. FF = 20 psf; Random walls = 30 psf; LL = 80 psf. Given $f'_c = 3$ ksi; $f_y = 50$ ksi; $f_s = 20$ ksi; $n=9$; $k = 0.378$; $j = 0.874$; $R = 223$.
Design a beam by WSD,
Design the same beam by USD.

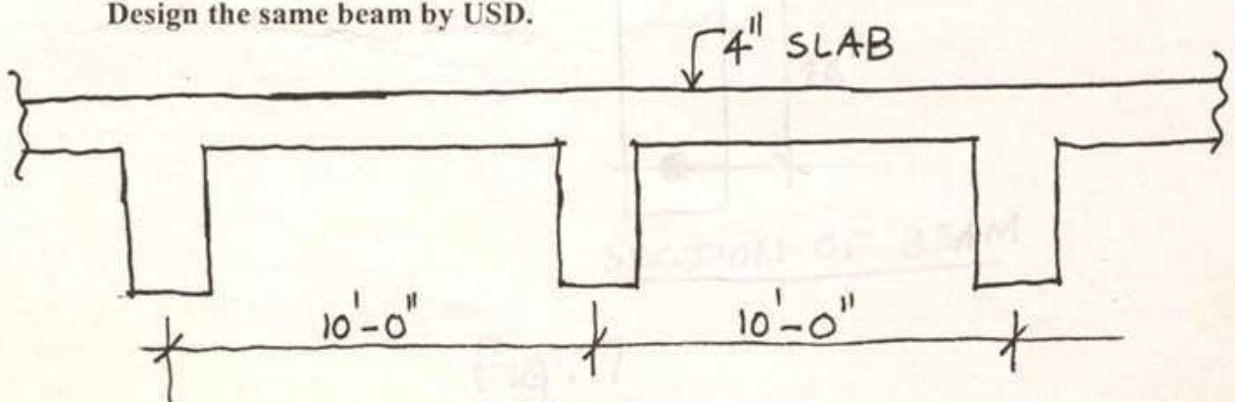
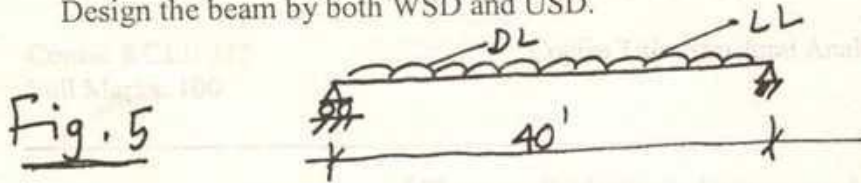

Fig. 4

10. A singly reinforced beam for a 40 ft. span (simply supported) with the following data DL excluding self wt. = 1.5 k/ft, LL = 1.5 k/ft is shown in Fig. 5.
 Given $f'_c = 3$ ksi; $f_y = 50$ ksi; $f_s = 20$ ksi; $n=9$; $k = 0.378$; $j = 0.874$; $R = 223$
 Design the beam by both WSD and USD.



11. For the beam section shown in Fig. 6 Calculate the moment capacity
 i) by WSD
 ii) by USD
 Given $f'_c = 3$ ksi; $f_y = 50$ ksi; $f_s = 20$ ksi; $n=9$; $k = 0.378$; $j = 0.874$; $R = 223$

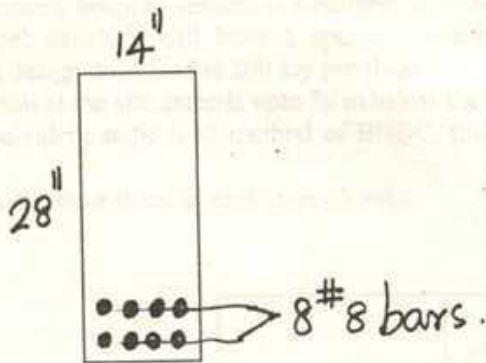

Fig. 6

12. For the beam and its cross section shown in Fig. 7 design the stirrups and make a neat sketch showing the stirrups. Use WSD. OR USD
 Given $f'_c = 3$ ksi; $f_y = 50$ ksi; $f_s = 20$ ksi; $n=9$; $k = 0.378$; $j = 0.874$; $R = 223$

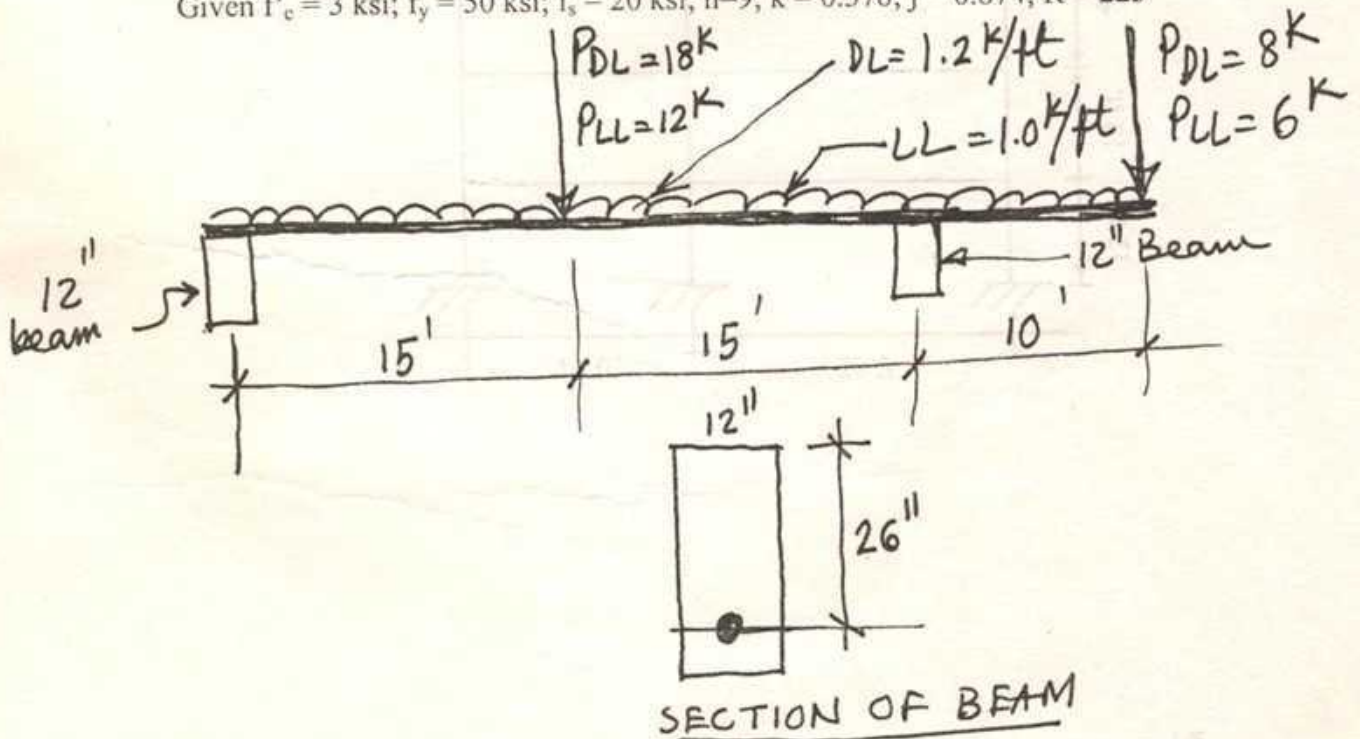

Fig. 7

The University of Asia Pacific
Department of Civil and Environmental Engineering
Final Examination Spring'2004

Course # CEE 331

Course Title: Environmental Engineering I

Full Marks: 150

Time: 3 Hours

Answer any six questions out of seven.

- (1). (a) Mention the primary objectives of water supply systems. (04)
- (b) What are the essential elements of water supply systems? (04)
- (c) State the Darcy's law. (04)
- (d) Define "Artesian aquifer & Aquicludes". (04)
- (e) A 120 mm diameter tube-well is sunk 40 m below static groundwater level. (09)
The depth of water in the tube-well while pumping is 35 m. The radius of draw down is 30 m and the coefficient of permeability of the aquifer is 0.5 l/s/m^2 . Calculate the probable discharge of the well.
- (2). (a) What are the major problems (Quality aspect) in ground water of Bangladesh? (04)
- (b) Mention the basic quality requirements of drinking water. (05)
- (c) Which factors influence per capita water consumption? (04)
- (d) What is the main difference between "Exponential growth and "Uniform percentage growth rate method". (02)
- (e) Discuss briefly the general consideration for planning and design of a low cost water supply scheme. (10)
3. (a). State the Stokes laws. (03)
- (b). Which factors affect the settlements of a particle in water? (03)
- (c). What are the purposes of "Screening" in water treatment process? (04)
- (d). Write down the importance of "Detention Period" in water treatment process. (03)
- (e). Design a coagulation-cum-sedimentation tank with continuous flow for a (12)

population of 70,000 with a daily per capita water allowance of 100 liters. Make suitable assumptions where needed.

4. (a). Discuss briefly the theory of filtration. (10)
- (b). What should be the area of basin when a rectangular settling tank without mechanical equipment is to treat 2 million liters per day of raw water. The required sedimentation period is 4 hours, velocity of flow is 8 cm/minute, depth of water and sediment 4.2m. Consider 1.2m allowances for sedimentation process. (08)
- (c). Define pressure filter. Discuss the method of construction of a pressure filter. (07)
5. (a). Why disinfection's is done in drinking water? (03)
- (b). Mention the different methods of disinfections. (03)
- (c). Discuss the salt-water intrusion process in coastal areas. (06)
- (d). What do you mean by water softening? (03)
- (e). Design a zeolite- softener for an industrial concern, using the following data: (10)
- (i). Quantity of soft water required per hour = 40,000 litres
 - (ii). Hardness present in raw water as $\text{CaCO}_3 = 400$ ppm
 - (iii). Hardness to be obtained in the treated supplies = 30 ppm.
 - (iv). Ion exchange capacity of the zeolite = 10 kg of hardness per cu.m.of zeolite
 - (v). Salt required for regeneration of exhausted zeolite = 50 kg per cu.m. of zeolite. Assume that the industry works for 2 shifts of 8 hours each, per day. Make suitable assumption , if not given.
6. (a). What is the main problem in treating arsenic contaminated water? (02)
- (b). Discuss the advantage and disadvantage of Co-precipitation, Sorption & Membrane techniques in treating arsenic contaminated water. (12)
- (c). In constructing an elevated circular R.C.C. tank if the cost per m^2 of the shell is 1.5 times to that of the floor, what will be the most economical dimensions of the tank. Assume thickness of the floor= thickness of the shell. (08)
- (d). What are the purposes of a sand filter? (03)
7. (a). What are the main purposeS of constructing water transmission and distribution pipeline? (04)
- (b). Discuss the disadvantage of " Branch and Loop network". (06)
- (c). Calculate the flow in each pipe in the loop (1) in the following pipe network. (15)

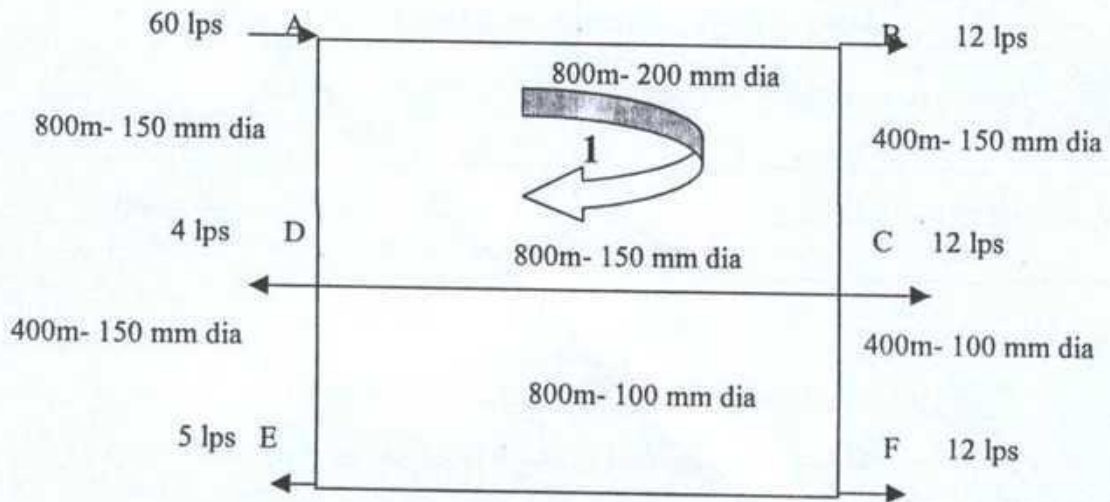

The University of Asia Pacific
Department of Civil and Environmental Engineering

Semester Examination: Spring 2004

Time : 3 Hours

Course Title: Geotechnical Engineering I

Course Number: CEE 341 (3 Credits)

There are **EIGHT** questions in this question paper. Answer any **SIX** questions. The numbers in the right indicate the mark of the questions.

Question 1

(a) Define degree of sensitivity of a soil. Why unconfined compressive strength of a disturbed clay sample is lower than the undisturbed sample?

2

(b) Define liquid limit, plastic limit, plasticity index, and shrinkage index.

2

(c) Why ASTM soil classification on grain size is not accurate? Why soil classification based on the plasticity chart is more accurate than ASTM classification based on grain size? Explain A-Line of the plasticity chart.

3

(d) An attempt was made to classify a soil sample based on the unified soil classification system using modified plasticity chart. The test results are summarized below:

9
3

Test Results for Liquid Limit Determination:

Number of Blows	Water Content (%)
18	45.5
22	42.1
28	36.5
35	32.5
50	25.0

Test Results for Plastic Limit Determination:

Weight of the wet sample at crumbling stage of threads = 35 gm

Weight of the oven dry sample = 30 gm

Classify the soil based on the modified plasticity chart. The chart is attached (Fig. 1) at the end of this question paper.

Question 2

(a) Derive the relationship between porosity and void ratio.

2

(b) Derive the following relationship:

5

$$\gamma = \frac{G + Se}{1 + e} \gamma_w$$

Where, γ = unit weight of the soil
G = Specific gravity of the soil
e = Void ratio
S = Degree of saturation
 γ_w = Unit weight of water

Simplify the relationship for 100% saturation and 0% saturation.

(c) Define relative density of a soil. Explain the significance of relative density of soil.

2

(d) A sample of silty clay had a volume of 14.88 cc. Its weight at the natural water content was 28.81 gm and after oven drying was 24.83 gm. The specific gravity of the solid constituents was 2.70. Calculate the void ratio, porosity, degree of saturation, and air content in the soil sample.

7 $\frac{2}{3}$

Question 3

(a) Explain the key features of standard Proctor test and modified Proctor test. Calculate the compaction energy for both tests. Draw the qualitative compaction curves for these tests.

3

(b) Mention different compaction methods. Explain factors affecting compaction in the field?

3

(c) Compare compaction and consolidation.

2

(d) The following are the results of standard Proctor test on a soil sample:

8 $\frac{2}{3}$

W (%)	5	10	14	20	25
ρ (gm/cc)	1.77	1.98	2.1	2.18	2.16

Plot the water content – dry density curve and obtain the optimum water content and maximum dry density. Calculate the water content necessary to completely saturate the sample at its maximum dry density, assuming no change in volume and $G = 2.7$.

Question 4

- (a) Explain earth pressure at rest, active earth pressure, and passive earth pressure. 1.5
- (b) Explain qualitative pressure on a wall if soil condition is changed from active to passive states. 1.5
- (c) Derive expressions for critical depth and crack depth for a clay backfill. 2
- (d) A gravity retaining wall was constructed to support a stratified backfill as shown below. What is the total active force/unit width of the wall and what is the location of the resultant. 2

11
3

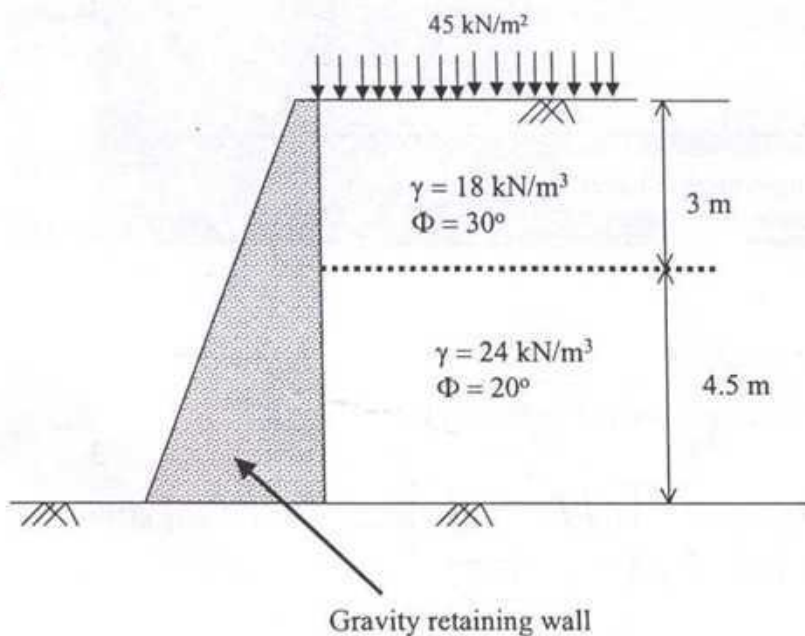

Question 5

- (a) Explain Darcy's law of permeability. Derive the relationship between superficial velocity and seepage velocity. 3
- (b) Derive the equation for calculating permeability based on variable head permeameter.

$3\frac{2}{3}$

(c) In a variable head permeability test, head causing flow was initially 50 cm and it drops 2 cm in 5 minutes. How much time will require to fall the head to 25 cm?

5

(d) For the flow net shown in below (a) How high would water rise if a pizometer is placed at (i) A, (ii) B, and (iii) C; (b) if $k=0.01$ mm/s, determine the seepage loss in $m^3/(day.m)$.

5

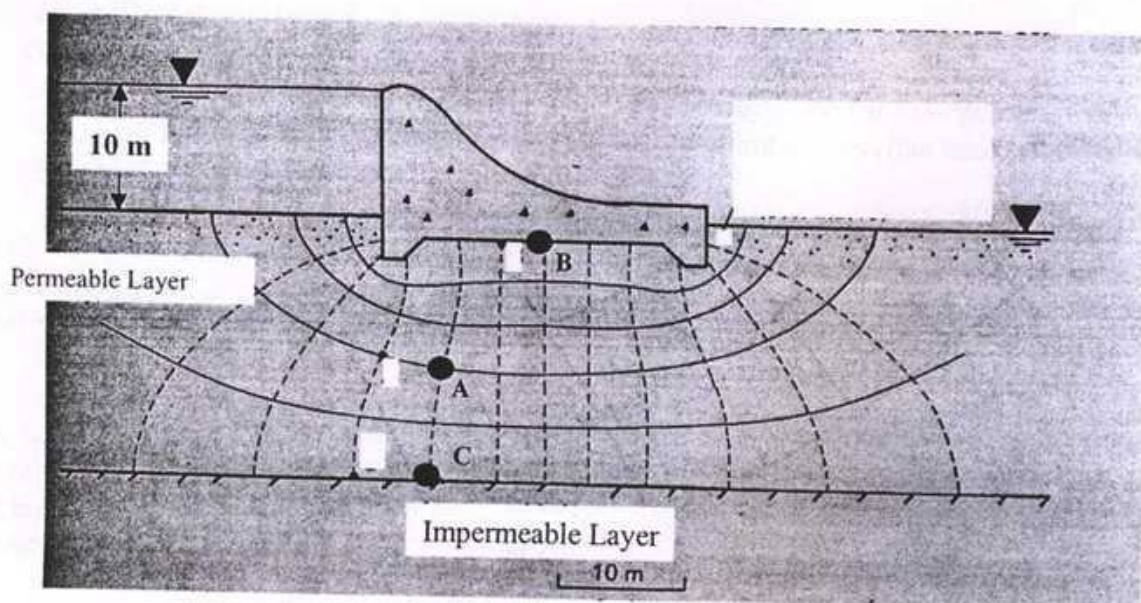

Question 6

(a) Derive the following equation for vane shear test in the field:

4

$$T = \Pi d^2 \tau_f \left[\frac{H}{2} + \frac{d}{6} \right]$$

The symbols carry the usual meaning.

(b) Derive the following relationship between the principal stresses at failure of triaxial test:

4

The University of Asia Pacific
Department of Civil and Environmental Engineering
Final Examination Spring 2004

Course #: CEE-411
 Full Marks: 100 (=10 × 10)

Course Title: Structural Analysis & Design -III
 Time: 3 hours

[Answer any 10 (ten) of the following 14 questions]

1. Use the Moment Distribution Method to draw the bending moment diagram of beam ABCD shown in the figure below [Given: $EI = 40 \times 10^3 \text{ k-ft}^2$].

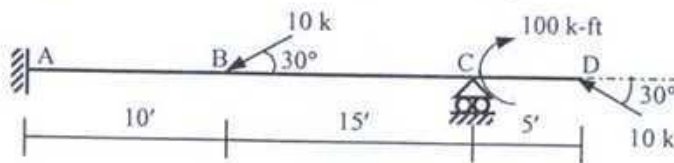

2. Solve Problem 1 using the Stiffness Method and neglecting axial deformations.
3. Solve Problem 1 using the Flexibility Method and including axial, shear and flexural deformations [Given: $EA = 150 \times 10^3 \text{ k}$, $GA^* = 50 \times 10^3 \text{ k}$, $EI = 40 \times 10^3 \text{ k-ft}^2$].
4. Using the Moment Distribution Method, draw the bending moment diagram of the frame shown in the figure below, if support A moves 0.10' downwards [Given: $EI = 40,000 \text{ k-ft}^2$].

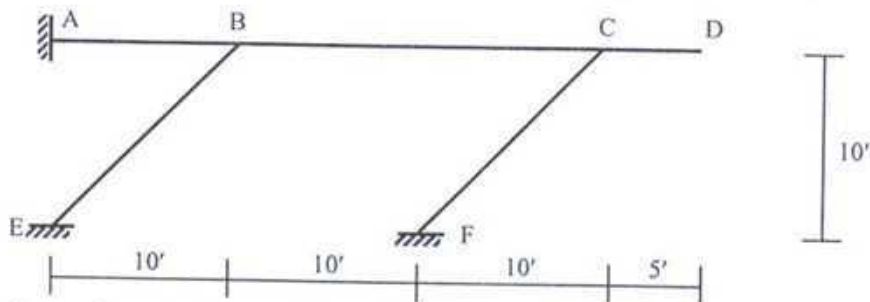

5. For the frame described in Problem 4, calculate the rotations at joints B and C using the Stiffness Method and neglecting axial deformations.
6. Using Flexibility Method and including flexural deformations only, draw bending moment diagram of the frame shown in the figure below if support A moves 0.10' downwards [Given: $EI = 40,000 \text{ k-ft}^2$].

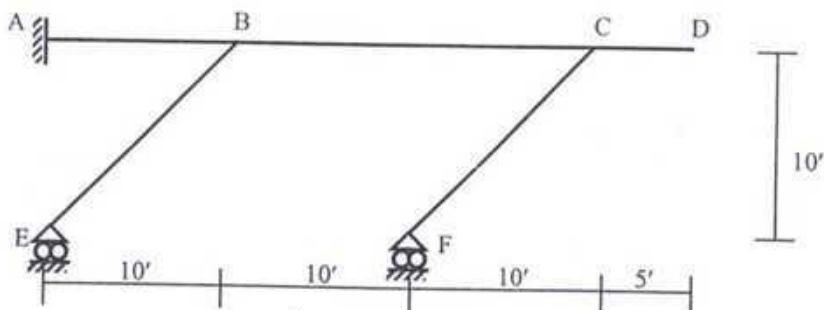

7. Determine the size of the stiffness matrix and flexibility matrix for the 2D frame and 2D truss shown in the figures below. For the frame, also determine the size of the stiffness matrix if axial deformations are neglected.

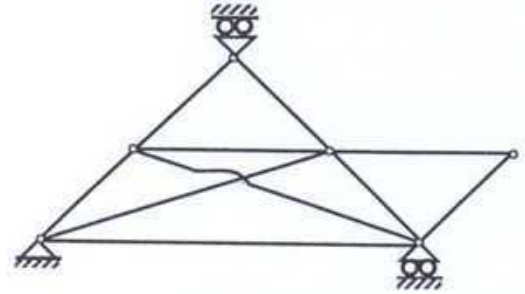
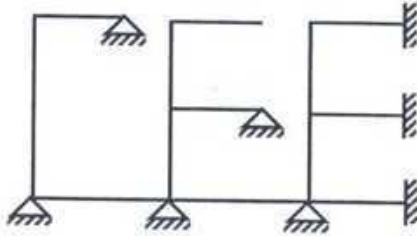

8. In the beam shown below, draw qualitative influence lines of R_B , $V_{C(L)}$, V_D , M_D and M_E . Also show placement of loads (do not calculate values) in order to obtain their maximum values for a uniformly distributed dead load of 1 k/ft, a moving uniformly distributed live load of 0.5 k/ft and a moving concentrated live load of 5 k.

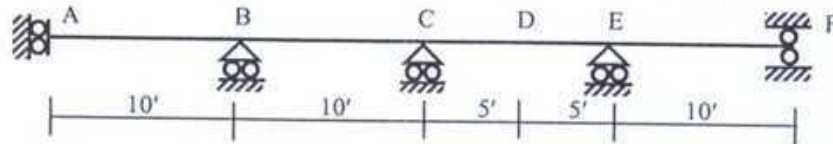

9. Formulate the stiffness matrix and load vector and write down the boundary conditions for the truss shown in the figure below [$EA/L = \text{constant} = 500 \text{ kip/ft}$].

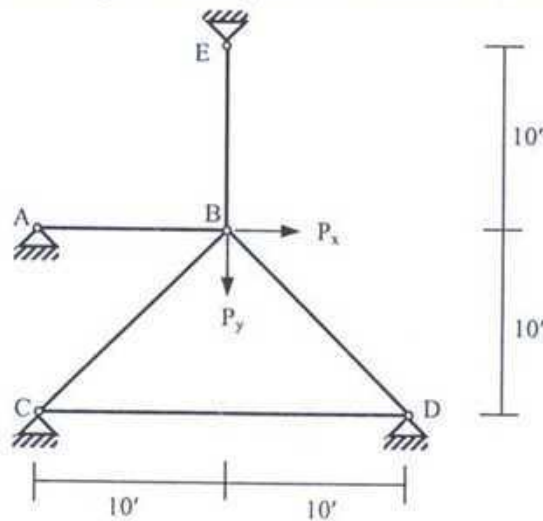

10. For the truss described in Problem 9, the joint B moves 0.10 ft vertically (downward) and 0.10 ft horizontally (rightward) under the action of the given loads. Calculate all the member forces, support reactions and the applied external forces P_x and P_y .
11. State the differences between the analyses of grids and 3D (three-dimensional) frames by Stiffness Method (mention the coordinates required, member properties required, unknowns per joint, direction of loads, forces/moments calculated).

The University of Asia Pacific
Department of Civil and Environmental Engineering
Final Examination, Spring 2004

Course # CEE 417
Full Marks: 100

Course Title: Structural Analysis & Design VI
Time: 2hr.

There are **SEVEN** questions in this paper. Answer any **FIVE**.

1. (a) Two plates are lap connected using $5/16$ inch transverse weld at the end deposited by E70XX electrodes (for which ϕ is 0.75 and nominal strength is 0.6 times the tensile strength of weld metal) as shown in Fig. 1. Using the same electrode design additional longitudinal welds at the two sides, so that the lap L may be minimized. The joint is to transmit a dead load of 80 kips and a live load of 160 kips. Use AISC/LRFD method and determine L . Limits on size of welds imposed by specifications are given in Table 1. (10)

Table 1. Fillet weld sizes

Size of Fillet weld, in	Maximum thickness of part, in
$1/8$	To $1/4$
$3/16$	Over $1/4$ to $1/2$
$1/4$	Over $1/2$ to $3/4$
$5/16$	Over $3/4$

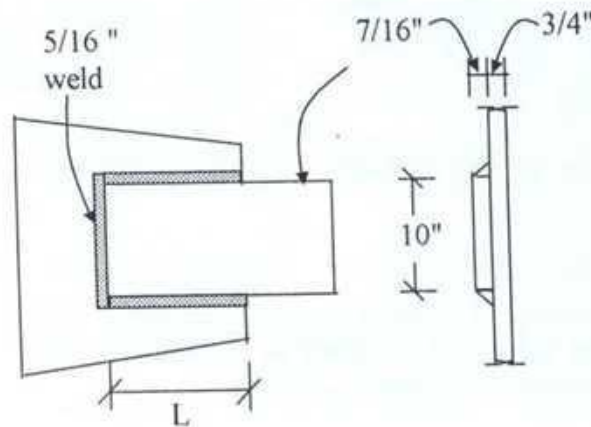

Fig. 1

- (b) Write short notes on strain aging.

(4)

- (c) The section shown in Fig. 2 is selected to be used as compression member. Check in accordance with AISC specifications whether the section satisfies local buckling criteria for two different yield strengths 36 ksi and 65 ksi. (6)

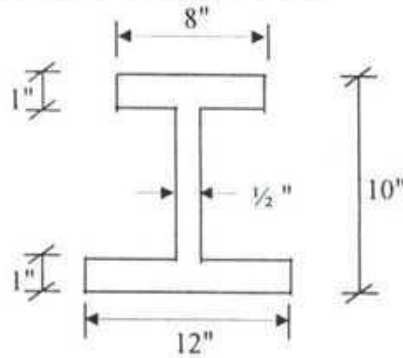

Fig. 2

2. (a) Using AISC/LRFD specification determine the block shear design strength of the splice shown in Fig 3. Fasteners are 7/8" A325 bolts in standard holes. All plates are of A36 steel. (14)

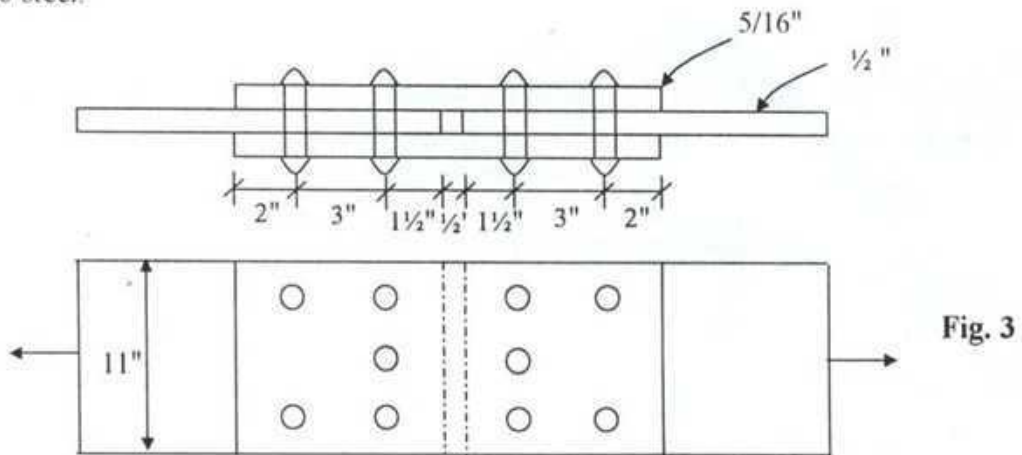

Fig. 3

- (b) What is residual stress? Draw qualitative thermal residual stress diagram for a W shape section. (6)

3. (a) An L 7×4× 1/2 angle is connected by two rows of 3/4 in bolts in the 7-inch leg and one row in the 4-in leg. Standard holes are used. Determine pitch " s " so that only two holes for 3/4 in fasteners are needed to be deducted in computing the net area. (10)

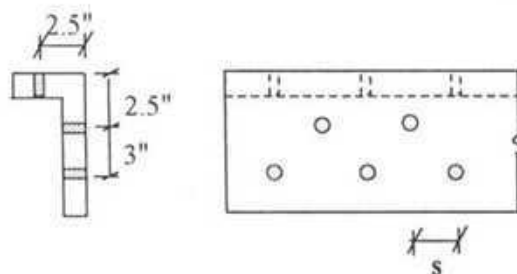
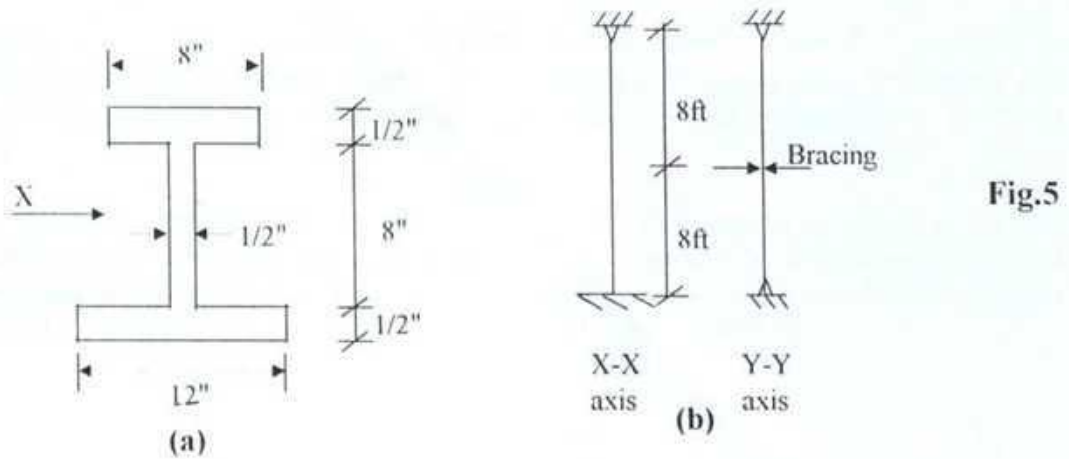

Fig. 4

- (b) Find the capacity of the 16 ft long column with the built-up section shown in Fig 5(a). (10)
 Support conditions for X-X and Y-Y axis are shown in Fig 5(b). Use $F_y = 42$ ksi.



4. (a) Determine the effective lengths for the columns AB, BC, CD and EF of the frame (16)
 shown in Fig.6. The moment of inertia for the columns and beams are shown in the
 figure. Annexure-1 provides necessary nomographs.

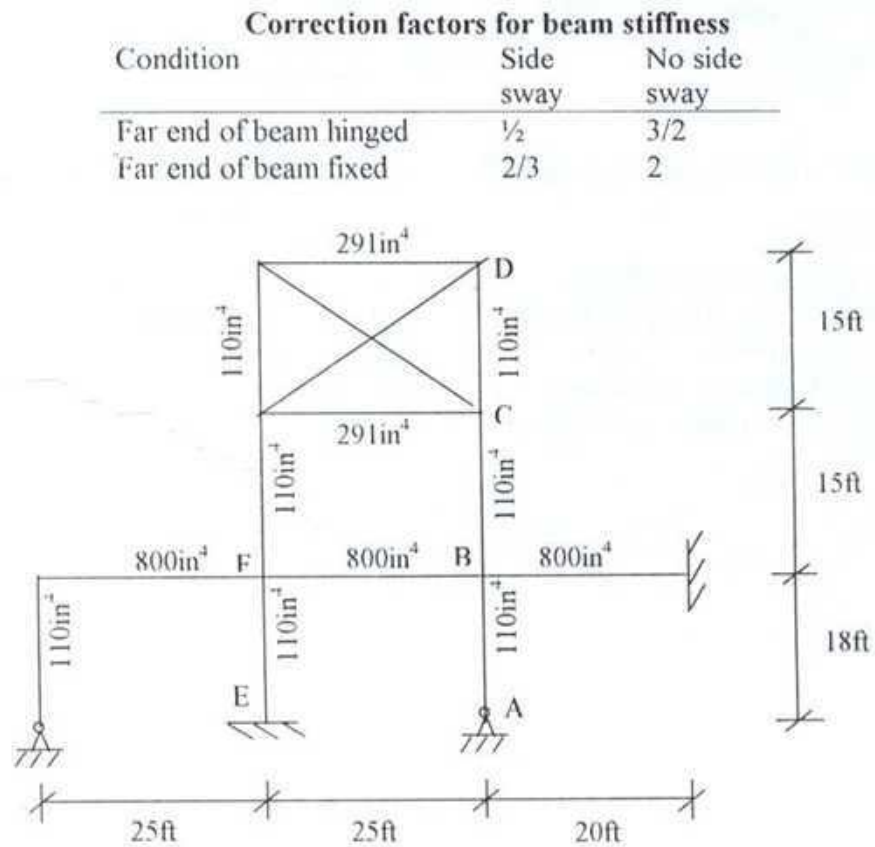

Fig. 6

- (b) Differentiate between stiffened and un stiffened elements with neat sketches. (4)
5. (a) What are different connections in a frame? Explain with neat sketches. (9)
- (b) Design a building column using W10 section provided in Annexure -2. The column is of A36 steel, 20 ft long and is to support a dead load of 75 kips and a live load of 170 kips. Assume that both ends are fixed supported in X and Y-axis. Given: $E=29000$ ksi. (11)
6. (a) A simply supported beam of span 25 ft having an I section as shown in Fig.7 is subjected to transverse load acting through the shear center. Determine the critical intensity of load w in lb/ft for lateral torsional buckling of the beam. Given: effective length coefficient=1; Poisson's Ratio=0.25; $C_b=1.13$; $E=30000$ ksi. (12)

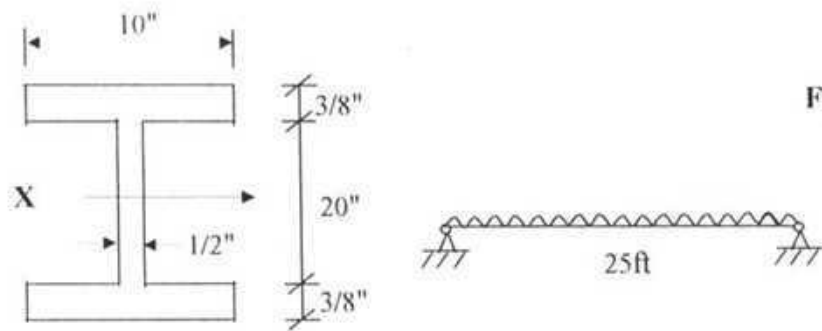

Fig. 7

- (b) Define: (i) Lateral Torsional Buckling; (ii) Compact section; (iii) Non Compact Section; (iv) Shape factor. (8)
7. Select the lightest W section to carry a uniformly distributed live load of 1.5 k/ft and dead load (excluding the wt of the beam) of 0.50 k/ft on a 40 ft span simply supported beam. Lateral supports are provided at 10 ft c/c spacing. Use steel with $F_y = 65$ ksi and AISC/ASD method of design. Live load deflection is to be limited to $1/300$ of the span. Check the selected section against local buckling. Annexure-3 is provided to facilitate the design. (20)

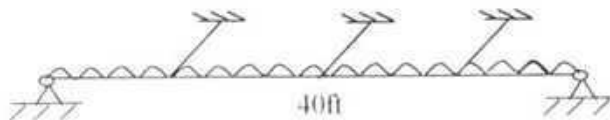

Fig. 8

Formula:

$$\begin{aligned}\phi R_n &= 0.75(0.6F_y A_{gv} + F_u A_m) \\ &= 0.75(0.6F_u A_m + F_y A_{gv})\end{aligned}$$

$$M_{cr} = C_b \left[\frac{\pi^2}{(KL)^2} EI_x GJ + \frac{\pi^4}{(KL)^4} EI_x G C_w \right]$$

$$C_b = \pi \sqrt{2I_x / F_y}$$

$$F_d = \begin{cases} \frac{F_y \left[1 - \frac{1}{2} \left(\frac{KL}{C_e} \right)^2 \right]}{\frac{5}{3} + \frac{3}{8} \left(\frac{KL}{C_e} \right) - \frac{1}{8} \left(\frac{KL}{C_e} \right)^3} \\ \frac{12\pi^2 F_y}{23 \left(\frac{KL}{r} \right)^2} \end{cases}$$

$$\begin{aligned}F_{cr} &= 0.658^{\lambda_c^2} F_y && \text{if } 0 \leq \lambda_c \leq 1.5 \\ &= 0.877 \frac{F_y}{\lambda_c} && \text{if } \lambda_c > 1.5\end{aligned}$$

$$\lambda_c = \frac{KL}{r\pi} \sqrt{\frac{F_y}{E}}$$

$$C_b = 1.75 - 1.05 \left(\frac{M_1}{M_2} \right) + 0.3 \left(\frac{M_1}{M_2} \right)^2 \leq 2.3$$

$$\begin{aligned}L_c &= \frac{76b_f}{\sqrt{F_y}} \\ &= \frac{20000}{F_y d} \\ &A_f\end{aligned}$$

$$F_b = 0.6F_y$$

$$= \left[\frac{2}{3} - \frac{F_y (L/r_r)^2}{1530 \times 10^3 C_b} \right] F_y$$
$$= \frac{170000 C_b}{(L/r_r)^2}$$

$$F_b = 0.6F_y$$

$$= \frac{12000 C_b}{Ld}$$
$$A_f$$

$$\text{if } 0 \leq L/r_r \leq \sqrt{\frac{102000 C_b}{F_y}}$$

$$\text{if } \sqrt{\frac{102000 C_b}{F_y}} \leq L/r_r \leq \sqrt{\frac{510000 C_b}{F_y}}$$

$$\text{if } L/r_r > \sqrt{\frac{510000 C_b}{F_y}}$$

$$\text{if } 0 \leq \frac{Ld}{A_f} \leq \frac{20000 C_b}{F_y \frac{d}{A_f}}$$

$$\text{if } \frac{Ld}{A_f} > \frac{20000 C_b}{F_y \frac{d}{A_f}}$$



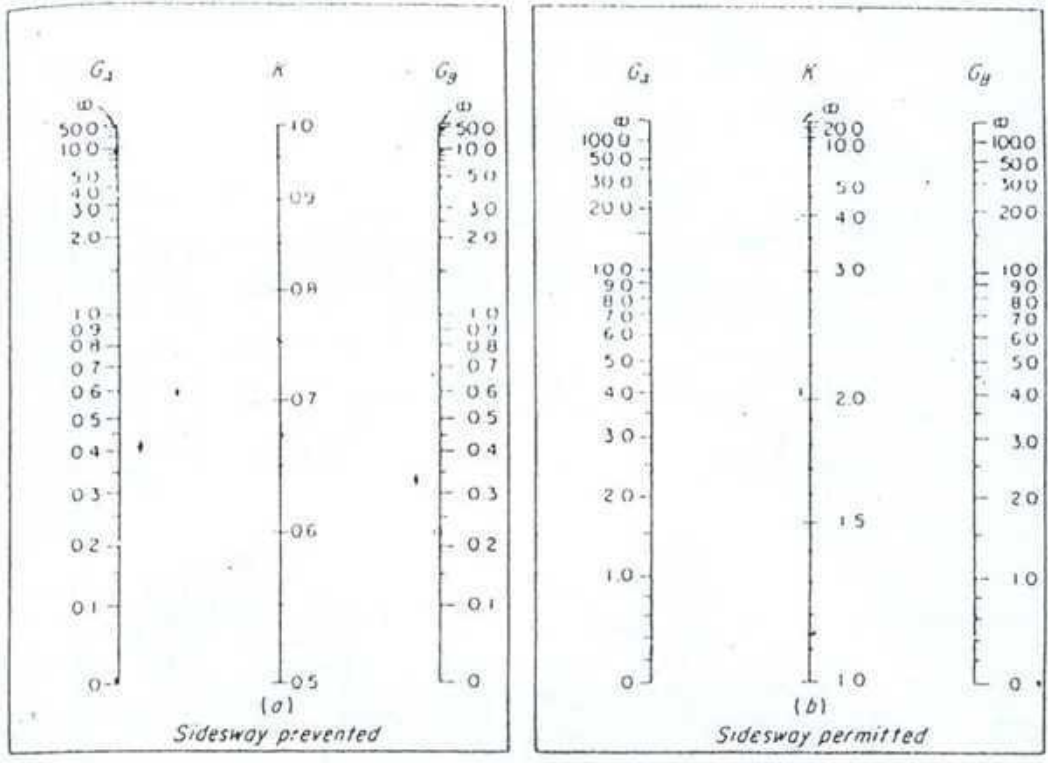

FIGURE 1
Nomograph for effective length of columns. (From Ref. 17.)

ANNEXURE I

ROLLED STEEL SHAPES

I
W SHAPES
Properties for designing

Nominal Size	Depth in.	Depth mm.	Area in. ²	Depth in.	Flange		Web Thick- ness in.	d in.	AXIS X-X		AXIS Y-Y	
					width in.	Thick- ness in.			f in.	r in.	f in.	r in.
10x10	11.2	28.42	10.415	11.38	1.742	7.55	.376	718.7	126.3	4.67	225.4	2.67
	100	29.43	10.345	11.12	1.118	.685	.961	625.0	112.4	4.61	226.6	2.65
	89	26.15	10.275	10.88	.998	.615	1.06	542.4	99.7	4.55	190.6	2.53
	77	22.87	10.61	10.195	.858	.575	1.20	457.2	86.1	4.49	157.4	2.60
	71	21.15	10.50	10.170	.828	.510	1.28	420.7	82.1	4.24	141.8	2.58
	66	19.41	10.38	10.117	.748	.457	1.37	322.5	73.7	4.24	125.2	2.57
	62	17.66	10.25	10.075	.683	.415	1.45	341.7	67.1	4.41	116.5	2.55
	54	15.28	10.12	10.028	.618	.368	1.63	305.7	60.4	4.29	102.9	2.54
	49	14.40	10.00	10.000	.552	.340	1.79	272.9	54.6	4.25	93.0	2.54
10x8	10	25	8.53	10.12	.622	.350	2.04	245.6	49.1	4.33	53.2	2.00
	89	21.48	8.34	9.94	.528	.318	2.36	209.7	42.2	4.27	44.9	1.78
	81	19.71	8.21	9.75	.432	.282	2.63	170.9	35.0	4.20	36.5	1.54
	75	18.53	8.07	9.57	.350	.259	2.52	157.3	30.8	4.28	35.2	1.34
	70	17.35	7.90	9.38	.280	.240	2.40	133.2	26.8	4.28	32.7	1.21
	65	16.15	7.75	9.20	.240	.240	2.40	106.3	21.5	4.34	29.7	1.25
8x8	8	20	6.57	9.00	.533	.257	1.16	271.8	60.4	3.71	85.6	2.12
	80	20.62	6.42	8.85	.432	.222	1.32	221.3	52.0	3.65	74.9	2.10
	75	19.06	6.30	8.75	.382	.210	1.53	187.2	43.2	3.61	60.9	2.08
	70	17.50	6.17	8.50	.332	.205	1.53	146.1	35.5	3.53	49.0	2.04
	65	16.00	6.07	8.25	.282	.205	1.53	126.5	31.1	3.50	42.5	2.03
	60	14.50	5.97	8.00	.232	.205	1.53	109.7	27.4	3.47	37.0	2.01
8x6	8	24	5.23	8.06	.467	.285	2.66	57.8	24.3	3.65	21.6	1.67
	75	24.06	5.08	7.93	.386	.245	3.07	42.5	20.8	3.42	18.2	1.51
8x5	8	20	4.82	8.14	.348	.248	4.08	49.2	17.0	3.43	2.50	1.20
	75	20.00	4.65	8.00	.285	.230	4.08	36.4	14.1	3.36	6.72	1.18

† Non-compact shape in A31, A32, A40 and A42.
‡ Non-compact shape in A24, A40 and A42.

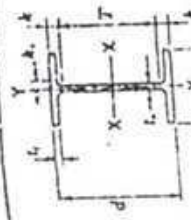

W SHAPES Dimensions

Designation	Area A in ²	Depth d in.	Web		Flange		Distance	
			Thickness t _w in.	t _w in.	Width b _f in.	Thickness t _f in.	T in.	k ₁ in.
W10x112	32.9	11.35	11%	10%	1.250	1 1/4	7%	1 3/8
x100	29.4	11.10	11%	10%	1.120	1 1/8	7%	1 3/8
x88	25.9	10.84	10%	10%	0.990	1	7%	1 3/8
x77	22.6	10.60	10%	10%	0.870	7/8	7%	1 3/8
x68	20.0	10.40	10%	10%	0.770	3/4	7%	1 3/8
x60	17.6	10.22	10%	10%	0.680	11/8	7%	1 3/8
x54	15.3	10.09	10%	10	0.615	1 1/8	7%	1 3/8
x49	14.1	9.98	10	10	0.560	1 1/8	7%	1 3/8
W10x45	13.3	10.10	10%	8	0.520	1 1/8	7%	1 3/8
x39	11.5	9.92	9%	8	0.530	1 1/8	7%	1 3/8
x33	9.71	9.73	9%	8	0.435	1 1/8	7%	1 3/8
W10x30	8.84	10.47	10%	5 1/2	0.510	1 1/8	8%	1 3/8
x25	7.6	10.33	10%	5 1/2	0.540	1 1/8	8%	1 3/8
x22	6.49	10.17	10%	5 1/2	0.350	1 1/8	8%	1 3/8
W10x17	5.62	10.24	10%	4	0.395	1 1/8	8%	1 3/8
x17	4.95	10.11	10%	4	0.320	1 1/8	8%	1 3/8
x15	4.41	9.99	10	4	0.270	1 1/8	8%	1 3/8
x12	3.54	9.57	9%	4	0.210	1 1/8	8%	1 3/8

W SHAPES Properties

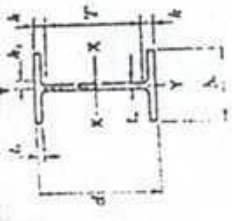

Shape	Compact Section										Plastic Modulus											
	F _y		F _u		r _x		r _y		d		I _x		I _y		S _x		S _y		Z _x		Z _y	
	b _f /t _f	F _y /F _u	d/t _w	F _y /F _u	r _x /t _w	r _y /t _w	r _x /t _w	r _y /t _w	d	d	I _x	I _y	I _x	I _y	S _x	S _y	Z _x	Z _y	Z _x	Z _y	Z _x	Z _y
12	12	12	12	12	12	12	12	12	12	12	12	12	12	12	12	12	12	12	12	12	12	12
112	4.2	15.0	2.88	0.87	216	125	4.56	236	45.3	2.68	15.1	147	69.2	10.9	2.65	10.9	130	61.0	10.9	2.65	10.9	130
100	4.6	16.3	2.85	0.96	623	112	4.60	207	40.0	2.65	10.9	130	61.0	10.9	2.65	10.9	130	61.0	10.9	2.65	10.9	130
88	5.2	17.9	2.83	1.07	534	88	5.2	179	34.8	2.61	10.9	130	61.0	10.9	2.61	10.9	130	61.0	10.9	2.61	10.9	130
77	5.9	20.0	2.80	1.20	455	77	5.9	200	26.4	2.52	10.9	130	61.0	10.9	2.52	10.9	130	61.0	10.9	2.52	10.9	130
68	6.6	22.1	2.79	1.33	394	68	6.6	221	23.0	2.37	10.9	130	61.0	10.9	2.37	10.9	130	61.0	10.9	2.37	10.9	130
60	7.4	24.3	2.77	1.49	341	60	7.4	243	20.5	2.16	10.9	130	61.0	10.9	2.16	10.9	130	61.0	10.9	2.16	10.9	130
54	8.2	27.3	2.75	1.64	303	54	8.2	273	18.2	1.94	10.9	130	61.0	10.9	1.94	10.9	130	61.0	10.9	1.94	10.9	130
49	8.9	30.4	2.74	1.78	272	49	8.9	304	15.7	1.74	10.9	130	61.0	10.9	1.74	10.9	130	61.0	10.9	1.74	10.9	130
45	6.5	28.9	2.18	2.03	248	45	6.5	289	13.3	1.91	10.9	130	61.0	10.9	1.91	10.9	130	61.0	10.9	1.91	10.9	130
39	7.5	31.5	2.16	2.34	209	39	7.5	315	11.3	1.98	10.9	130	61.0	10.9	1.98	10.9	130	61.0	10.9	1.98	10.9	130
33	9.1	33.6	2.12	2.81	170	33	9.1	336	9.20	1.94	10.9	130	61.0	10.9	1.94	10.9	130	61.0	10.9	1.94	10.9	130
30	5.7	34.9	1.55	3.53	170	30	5.7	349	5.25	1.97	10.9	130	61.0	10.9	1.97	10.9	130	61.0	10.9	1.97	10.9	130
26	6.6	39.7	1.54	4.07	144	26	6.6	397	4.25	1.96	10.9	130	61.0	10.9	1.96	10.9	130	61.0	10.9	1.96	10.9	130
22	8.0	42.4	1.51	4.91	118	22	8.0	424	3.25	1.93	10.9	130	61.0	10.9	1.93	10.9	130	61.0	10.9	1.93	10.9	130
19	5.1	41.4	1.03	6.45	95.3	19	5.1	414	2.25	1.87	10.9	130	61.0	10.9	1.87	10.9	130	61.0	10.9	1.87	10.9	130
17	6.1	42.1	1.01	7.64	81.9	17	6.1	421	1.75	1.84	10.9	130	61.0	10.9	1.84	10.9	130	61.0	10.9	1.84	10.9	130
15	7.4	43.4	0.99	9.25	68.9	15	7.4	434	1.25	1.81	10.9	130	61.0	10.9	1.81	10.9	130	61.0	10.9	1.81	10.9	130
12	9.4	47.5	0.95	11.9	53.8	12	9.4	475	0.75	1.78	10.9	130	61.0	10.9	1.78	10.9	130	61.0	10.9	1.78	10.9	130

ALLOWABLE STRESS DESIGN SELECTION TABLE

For shapes used as beams

Sx

L _c	f _y = 50 ksi			S _x	Shape	Depth d	f _r	f _y = 36 ksi		
	Fl	Fi	M _a					Fl	Fi	M _a
10.3	11.1	12.50	448	W 33x141	33 1/2	—	12.2	15.4	887	
8.8	11.0	1210	439	W 36x135	35 1/2	—	12.3	13.0	869	
9.4	13.4	1200	435	W 30x148	30 3/4	—	11.1	18.7	863	
10.3	35.5	1150	419	W 18x211	20 3/4	—	12.2	49.3	830	
11.2	27.1	1150	417	W 21x162	22 1/2	—	13.2	37.6	826	
11.6	21.1	1140	414	W 24x162	25	—	13.7	29.3	820	
12.5	16.6	1130	411	W 27x146	27 1/2	—	14.7	23.0	814	
9.9	10.8	1120	406	W 33x130	33 3/4	—	12.1	13.8	804	
9.4	11.6	1050	350	W 30x132	30 3/4	—	11.1	16.1	752	
10.3	25.1	1050	350	W 21x166	22 1/2	—	13.1	34.8	752	
11.6	18.9	1020	371	W 18x152	20 1/2	—	12.1	45.4	752	
8.6	10.7	987	359	W 33x118	32 1/2	—	13.6	26.3	735	
9.4	10.8	976	355	W 30x124	30 3/4	—	12.0	12.6	711	
9.0	13.3	949	345	W 27x129	27 1/2	—	11.1	15.0	703	
10.2	30.0	946	344	W 18x175	20	—	10.6	18.4	683	
9.4	9.9	905	329	W 30x116	30	—	12.0	41.7	681	
11.2	16.6	905	329	W 24x131	24 1/2	—	11.1	13.8	651	
11.1	21.8	905	329	W 21x147	22	—	13.6	23.4	651	
10.1	21.5	873	310	W 18x158	19 1/2	—	13.2	30.3	651	
8.9	9.8	872	299	W 30x108	29 1/2	—	11.9	39.3	614	
9.0	11.5	822	299	W 27x114	27 1/2	—	11.1	12.3	592	
11.1	15.6	811	295	W 21x132	21 1/2	—	10.6	15.9	592	
11.5	14.9	800	291	W 24x117	24 1/2	—	13.1	27.2	584	
10.0	23.3	776	282	W 18x143	19 1/2	—	13.5	20.8	576	
11.1	18.3	751	273	W 21x122	21 1/2	—	11.8	35.1	558	
7.9	9.7	740	269	W 30x99	29 1/2	—	13.1	25.4	541	
9.0	10.2	734	267	W 27x102	27 1/2	—	10.9	11.4	533	
11.4	15.2	710	258	W 24x104	24	—	10.6	14.2	529	
10.0	23.1	704	256	W 18x130	19 1/2	—	13.5	18.4	511	
11.1	16.8	685	249	W 21x111	21 1/2	—	11.8	32.2	507	
7.2	6.6	674	245	W 30x90	29 1/2	58.1	10.0	11.4	485	
8.1	6.1	674	245	W 24x103	24 1/2	—	9.5	16.7	485	
8.9	6.5	668	243	W 27x94	26 3/4	—	10.5	12.8	461	
10.1	21.0	635	231	W 18x119	19	—	11.9	29.1	457	
11.0	15.4	624	227	W 21x101	21 1/2	—	13.0	21.3	449	
8.1	10.9	611	222	W 24x94	24 1/2	—	9.6	15.1	440	
6.0	5.4	586	213	W 27x84	26 1/2	—	10.5	11.0	422	
10.0	18.7	561	204	W 18x106	18 1/2	—	11.8	26.0	404	
8.1	8.6	539	196	W 24x84	24 1/2	—	9.5	13.3	388	
7.5	8.1	538	192	W 21x93	21 1/2	—	8.9	16.8	380	
13.1	21.7	503	190	W 14x120	14 1/2	—	15.5	44.1	376	
10.0	17.4	467	186	W 18x97	18 1/2	—	11.8	24.1	372	

ANNEXURE B

ALLOWABLE STRESS DESIGN SELECTION TABLE

For shapes used as beams

Sx

L _c	f _y = 50 ksi			S _x	Shape	Depth d	f _r	f _y = 36 ksi		
	Fl	Fi	M _a					Fl	Fi	M _a
8.1	8.6	484	176	W 24x 76	23 1/2	—	9.5	11.8	348	
8.3	20.2	481	175	W 16x100	17	—	11.0	28.1	347	
13.1	29.2	476	173	W 14x109	14 1/2	58.6	15.4	40.6	343	
7.5	10.9	470	171	W 21x 83	21 1/2	—	8.8	15.1	339	
9.9	15.5	457	166	W 18x 86	18 1/2	—	11.7	21.5	329	
13.0	26.7	432	157	W 14x 99	14 1/2	48.5	15.4	37.0	311	
9.3	18.0	426	155	W 16x 89	16 1/2	—	10.9	25.0	307	
7.4	8.5	424	154	W 24x 68	23 3/4	—	9.5	10.2	305	
7.4	9.6	415	151	W 21x 73	21 1/2	—	8.8	13.4	299	
9.8	13.7	402	146	W 18x 76	18 1/2	64.2	11.6	19.1	289	
13.0	24.5	385	143	W 14x 90	14	40.4	15.3	34.0	283	
7.4	8.9	385	140	W 21x 68	21 1/2	—	8.7	12.4	277	
9.2	15.8	369	134	W 16x 77	16 1/2	—	10.9	21.9	265	
5.8	6.4	360	131	W 24x 62	23 3/4	—	7.4	8.1	259	
7.4	8.1	349	127	W 21x 62	21	—	8.7	11.2	251	
6.8	11.1	349	127	W 18x 71	18 1/2	—	8.1	15.5	251	
9.1	20.2	338	123	W 14x 82	14 1/2	—	10.7	28.1	244	
10.9	26.0	325	118	W 12x 87	12 1/2	—	12.8	36.2	234	
6.8	10.4	322	117	W 18x 65	18 1/2	—	8.0	14.4	232	
9.2	13.9	322	117	W 16x 67	16 1/2	—	10.8	19.3	232	
5.0	6.3	314	114	W 24x 55	23 3/4	—	7.0	7.5	226	
9.0	18.6	308	112	W 14x 74	14 1/2	—	10.6	25.9	222	
5.9	6.7	305	111	W 21x 57	21	—	6.9	9.4	220	
6.8	9.6	297	108	W 18x 60	18 1/2	—	8.0	13.3	214	
10.8	24.0	294	107	W 12x 79	12 1/2	62.6	12.8	33.3	212	
9.0	17.2	283	103	W 14x 68	14	—	10.6	23.9	204	
6.7	8.7	270	98.3	W 18x 55	18 1/2	—	7.9	12.1	195	
10.8	21.9	268	97.4	W 12x 72	12 1/2	52.3	12.7	30.5	193	
5.6	6.0	260	94.5	W 21x 50	20 1/2	—	6.9	7.8	187	
6.4	10.3	254	92.2	W 16x 57	16 1/2	—	7.5	14.3	183	
9.0	15.5	254	92.2	W 14x 61	13 3/4	—	10.6	21.5	163	
4.7	5.9	224	81.6	W 21x 44	20 1/2	—	6.6	7.0	162	
6.3	9.1	223	81.0	W 16x 50	16 1/2	—	7.5	12.7	160	
5.4	6.8	217	78.8	W 18x 46	18	—	6.4	9.4	156	
8.0	17.5	215	78.0	W 12x 58	12 1/2	—	10.6	24.4	154	
7.2	12.7	214	77.8	W 14x 53	13 3/4	—	6.5	17.7	154	
6.3	10.2	200	72.7	W 16x 45	16 1/2	—	7.4	11.4	144	
8.0	15.9	184	70.6	W 12x 53	12	55.9	10.6	22.0	140	
11.5	19.3	183	70.3	W 12x 48	12 3/4	—	8.5	16.0	139	

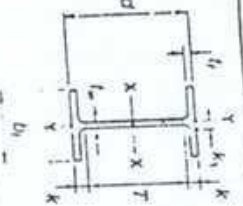

W SHAPES
Dimensions

Designation	Area A in. ²	Depth d in.	Web		Flange		Distance			
			Thickness t _w in.	t _w / d in.	Width b _f in.	Thickness t _f in.	T in.	A in.	A ₁ in.	
W 30 x 148 ¹	43.5	30.67	30%	0.650	10/480	1.180	28%	2	1	1
x 132	38.9	30.31	30%	0.615	10/545	1.000	28%	1 1/2	1 1/2	1 1/2
x 124	36.5	30.17	30%	0.585	10/515	0.950	28%	1 1/2	1 1/2	1 1/2
x 116	34.2	30.01	30	0.565	10/495	0.850	28%	1 1/2	1 1/2	1 1/2
x 106	31.7	29.63	29%	0.545	10/475	0.760	28%	1 1/2	1 1/2	1 1/2
x 99	29.1	29.65	29%	0.520	10/450	0.670	28%	1 1/2	1 1/2	1 1/2
x 90	26.4	29.53	29%	0.470	10/400	0.610	28%	1 1/2	1 1/2	1 1/2
W 27 x 539 ²	158.0	32.52	32%	1.970	15/255	3.540	3%	24	4 1/2	1 1/2
x 494 ¹	145.0	31.97	32	1.810	15/295	3.270	3%	24	4 1/2	1 1/2
x 448 ¹	131.0	31.42	31%	1.650	14/340	2.990	3%	24	3 3/4	1 1/2
x 407 ¹	119.0	30.87	30%	1.520	14/380	2.720	2%	24	3 3/4	1 1/2
x 368 ¹	108.0	30.39	30%	1.380	14/465	2.480	2%	24	3 3/4	1 1/2
x 336 ¹	98.7	30.00	30	1.260	14/545	2.280	2%	24	3 3/4	1 1/2
x 307 ¹	90.2	29.61	29%	1.160	14/665	2.090	2%	24	3 3/4	1 1/2
x 281 ¹	82.6	29.29	29%	1.080	14/800	1.930	2%	24	2 3/4	1 1/2
x 258 ¹	75.7	28.96	29	0.980	14/950	1.770	1%	24	2 3/4	1 1/2
x 235 ¹	69.1	28.66	28%	0.910	14/1100	1.610	1%	24	2 3/4	1 1/2
x 217 ¹	63.8	28.43	28%	0.830	14/1275	1.500	1%	24	2 3/4	1 1/2
x 194 ¹	57.0	28.11	28%	0.750	14/1475	1.340	1%	24	2 3/4	1 1/2
x 178 ¹	52.3	27.81	27%	0.725	14/1700	1.190	1%	24	1 3/4	1 1/2
x 161 ¹	47.4	27.59	27%	0.660	14/2000	1.080	1%	24	1 3/4	1 1/2
x 146 ¹	42.9	27.38	27%	0.605	13/265	0.975	1	24	1 3/4	1 1/2
W 27 x 129 ²	37.8	27.63	27%	0.610	10/310	1.100	1%	24	1 3/4	1 1/2
x 114	33.5	27.29	27%	0.570	10/370	0.930	1%	24	1 3/4	1 1/2
x 102	30.0	27.09	27%	0.515	10/430	0.830	1%	24	1 3/4	1 1/2
x 94	27.7	26.92	26%	0.490	9/590	0.745	1%	24	1 3/4	1 1/2
x 84	24.8	26.71	26%	0.460	9/660	0.640	1%	24	1 3/4	1 1/2

¹For application refer to Notes in Table 2.
²Heavier shapes in this series are available from some producers.
Shapes in shaded rows are not available from domestic producers.

W SHAPES
Properties

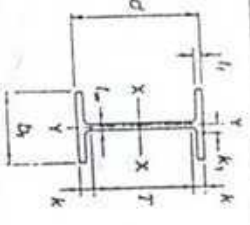

Nominal Wt. per ft. lb.	Compact Section Criteria			r _x in.	d/A	Elastic Properties						Plastic Modulus		
	b _x /2t _f in.	r _x ² ksi	d/L in.			r _y ² ksi	I in. ⁴	S in. ³	r in.	I in. ⁴	S in. ³	r in.	Z _x in. ³	Z _y in. ³
148	4.4	—	47.2	29.7	2.70	2.48	6690	436	12.4	227	47.3	2.28	500	68.0
132	5.3	—	49.3	27.2	2.66	2.87	5770	380	12.2	196	37.2	2.25	437	58.4
124	5.7	—	51.6	24.8	2.66	3.09	5360	355	12.1	181	34.4	2.23	408	54.0
116	6.2	—	53.1	23.4	2.64	3.36	4930	329	12.0	164	31.3	2.19	378	49.2
108	6.9	—	54.7	22.0	2.61	3.75	4470	299	11.5	146	27.9	2.15	346	43.5
99	7.8	—	57.0	20.3	2.57	4.23	3990	269	11.7	128	24.5	2.10	312	38.6
90	8.5	58.1	62.8	18.7	2.56	4.65	3620	245	11.7	115	22.1	2.09	283	34.7
539	2.2	—	16.5	—	4.10	0.60	25500	1570	12.7	2110	277	3.66	1880	437
494	2.3	—	17.7	—	4.05	0.65	22900	1440	12.6	1890	250	3.61	1710	394
448	2.5	—	19.0	—	4.01	0.70	20400	1300	12.5	1670	224	3.57	1530	351
407	2.7	—	20.3	—	3.96	0.77	18100	1170	12.3	1480	200	3.52	1360	313
368	3.0	—	22.0	—	3.93	0.84	16100	1060	12.2	1310	179	3.48	1240	279
336	3.2	—	23.8	—	3.89	0.90	14500	970	12.1	1170	161	3.45	1130	252
307	3.5	—	25.5	—	3.86	0.98	13100	894	12.0	1050	146	3.42	1020	227
281	3.7	—	27.6	—	3.81	1.06	11900	824	11.9	963	133	3.40	933	206
258	4.0	—	29.6	—	3.78	1.15	10800	742	11.8	859	120	3.37	850	187
235	4.4	—	31.5	—	3.74	1.25	9860	674	11.8	769	108	3.33	769	168
217	4.7	—	34.3	—	3.71	1.34	8970	624	11.7	681	99.8	3.29	708	154
194	5.2	—	37.5	—	3.67	1.43	8200	556	11.7	618	88.1	3.26	628	136
178	5.9	—	41.8	—	3.64	1.54	7520	502	11.6	555	78.8	3.26	567	122
161	6.5	—	45.3	—	3.60	1.66	6990	455	11.5	497	70.9	3.24	512	109
146	7.2	—	48.3	—	3.58	1.82	6530	411	11.4	443	63.5	3.21	461	97
129	4.5	—	45.3	32.2	2.59	2.51	4760	345	11.2	184	36.8	2.21	395	57.6
114	5.4	—	47.9	28.8	2.58	2.91	4090	299	11.0	159	31.5	2.18	343	49.3
102	6.0	—	52.6	23.9	2.56	3.26	3630	267	11.0	139	27.8	2.15	305	43.4
94	6.7	—	54.9	21.5	2.53	3.62	3270	243	10.9	124	24.8	2.12	278	38.8
84	7.8	—	58.1	19.6	2.49	4.19	2850	213	10.7	106	21.2	2.07	244	33.2

W SHAPES Dimensions

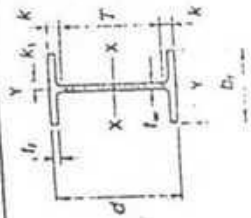

Designation	Area A In. ²	Depth d In.	Web		Flange		Distance		
			Thickness t _w In.	$\frac{L_w}{2}$ In.	Width b _f In.	Thickness t _f In.	T In.	k In.	A ₁ In.
W 24 x 49 ^a	144.0	29.65	29% 1.970	1	14.115	14% 3.540	39% 21	4 1/4	1 1/4
x 45 ^a	132.0	29.09	29% 1.810	1 1/4	13.955	14% 3.270	3% 3	4 1/4	1 1/4
x 40 ^a	119.0	28.54	28% 1.650	1 1/2	13.800	13% 2.990	3	3 3/4	1 1/4
x 37 ^a	108.0	27.99	28% 1.520	1 1/2	13.660	13% 2.720	2 1/2	3 1/2	1 1/4
x 33 ^a	98.4	27.52	27% 1.380	1 1/2	13.520	13% 2.480	2 1/2	3 1/4	1 1/4
x 30 ^a	89.8	27.13	27% 1.260	1 1/2	13.405	13% 2.280	2 1/2	3 1/4	1 1/4
x 27 ^a	82.0	26.73	26% 1.160	1 1/2	13.305	13% 2.090	2 1/2	2 3/4	1 1/4
x 25 ^a	73.5	26.34	26% 1.040	1 1/2	13.185	13% 1.890	1 1/2	2 3/4	1 1/4
x 22 ^a	67.2	26.02	26% 0.960	1 1/2	13.110	13% 1.730	1 1/2	2 1/2	1 1/4
x 20 ^a	60.7	25.71	25% 0.870	1 1/2	13.010	13% 1.600	1 1/2	2 1/2	1 1/4
x 19 ^a	56.3	25.47	25% 0.810	1 1/2	12.950	12% 1.570	1 1/2	2 1/2	1 1/4
x 17 ^a	51.7	25.24	25% 0.750	1 1/2	12.890	12% 1.460	1 1/2	2 1/2	1 1/4
x 16 ^a	47.7	25.00	25% 0.705	1 1/2	12.955	13% 1.220	1 1/2	2 1/2	1 1/4
x 14 ^a	43.0	24.74	24% 0.650	1 1/2	12.900	12% 1.090	1 1/2	1 3/4	1 1/4
x 13 ^a	38.5	24.48	24% 0.605	1 1/2	12.855	12% 0.960	1 1/2	1 3/4	1 1/4
x 12 ^a	34.4	24.26	24% 0.550	1 1/2	12.800	12% 0.850	1 1/2	1 1/2	1 1/4
x 10 ^a	30.6	24.06	24% 0.500	1 1/2	12.750	12% 0.750	1 1/2	1 1/2	1 1/4
W 24 x 103 ^b	30.3	24.53	24% 0.550	1 1/2	9.000	9% 0.980	1	1 1/2	1 1/4
x 94	27.7	24.31	24% 0.515	1 1/2	9.065	9% 0.875	1	1 1/2	1 1/4
x 84	24.7	24.10	24% 0.470	1 1/2	9.020	9% 0.770	1	1 1/2	1 1/4
x 76	22.4	23.92	23% 0.440	1 1/2	8.990	9% 0.680	1	1 1/2	1 1/4
x 68	20.1	23.73	23% 0.415	1 1/2	8.965	9% 0.585	1	1 1/2	1 1/4
W 24 x 62	18.2	23.74	23% 0.430	1 1/2	7.040	7% 0.590	1	1 1/2	1 1/4
x 55	16.2	23.57	23% 0.395	1 1/2	7.005	7% 0.505	1	1 1/2	1 1/4

^aFor application refer to Notes in Table 2.
^bHeavier shapes in this series are available from some producers.
 Shapes in shaded rows are not available from domestic producers.

W SHAPES Properties

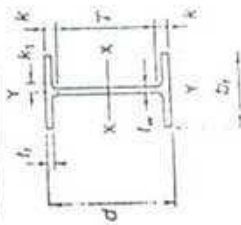

Nominal Wt. per ft. Lb.	Compact Section Criteria						Elastic Properties						Plastic Modulus	
	$\frac{d}{2t_f}$	$\frac{d}{t_w}$	$\frac{F_y}{F_u}$	$\frac{d}{L_c}$	F_y	F_u	Axis X-X			Axis Y-Y			Z_x	Z_y
							I	S	r	I	S	r		
492	2.0	15.1	—	—	3.90	—	19100	1290	11.5	1670	227	3.41	1550	376
450	2.1	16.1	—	—	3.76	—	17100	1170	11.4	1490	214	3.36	1410	337
408	2.3	17.3	—	—	3.71	—	15100	1060	11.3	1320	191	3.33	1250	301
370	2.5	18.4	—	—	3.67	—	13400	957	11.1	1160	170	3.28	1120	267
335	2.7	19.9	—	—	3.63	—	11900	864	11.0	1030	152	3.23	1020	234
306	2.9	21.5	—	—	3.60	—	10700	789	10.9	919	137	3.20	922	214
279	3.2	23.0	—	—	3.57	—	9600	718	10.8	825	124	3.17	835	181
250	3.5	25.3	—	—	3.53	—	8490	644	10.7	724	110	3.14	744	171
229	4.1	29.6	—	—	3.48	—	6820	531	10.6	578	82.8	3.08	666	137
192	4.4	31.4	—	—	3.46	—	6260	491	10.5	530	81.8	3.07	559	126
176	4.8	33.7	—	—	3.44	—	5680	450	10.5	479	74.3	3.04	511	115
162	5.3	35.5	—	—	3.45	—	5170	414	10.4	443	68.4	3.05	468	105
146	5.9	38.1	—	—	3.43	—	4580	371	10.3	391	60.5	3.01	418	93.2
131	6.7	40.5	—	—	3.40	—	4020	329	10.2	340	53.0	2.97	370	81.5
117	7.5	44.1	—	—	3.37	—	3540	291	10.1	297	46.5	2.94	307	71.4
104	8.5	48.1	—	—	3.35	—	3100	258	10.1	259	40.7	2.91	265	62.4
103	4.6	—	—	—	44.6	—	3000	245	9.96	119	26.5	1.99	290	41.5
94	5.2	—	—	—	47.2	—	2700	222	9.87	109	24.0	1.98	264	37.5
84	5.9	—	—	—	51.3	—	2370	196	9.79	94.4	20.9	1.95	234	32.6
76	6.6	—	—	—	54.4	—	2100	176	9.69	82.5	18.4	1.92	200	28.5
68	7.7	—	—	—	57.2	—	1830	154	9.55	70.4	15.7	1.87	177	24.1
62	6.0	—	—	—	55.2	—	1550	131	9.23	34.5	9.80	1.98	153	18.7
55	6.9	—	—	—	59.7	—	1350	114	9.11	29.1	8.30	1.94	134	12.3

The University of Asia Pacific
Department of Civil and Environmental Engineering
Final Examination Spring 2004

Course # CEE 437

Course Title: Environmental Engineering VI

Full Marks: 100

Time: 2 Hours

Answer any four questions out of five.

1. (a) What do you mean by environment & pollution? (04)
(b) Discuss the three basic functions of environment that performs in relation to man. (03)
(c) What are the major component and sub components of natural environment? (04)
(d) Define noise. What are the effects of noise pollution? (06)
(e) Discuss the different methods of noise control. (05)
(f) What are the environmental pollutants? (03)

2. (a) What is green house effect? (04)
(b) Briefly discuss the effects & control mechanism of green house effect. (15)
(c) What are the major causes of acid rain? (06)

3. (a) What does ISO stand for? (03)
(b) What do you mean by concept of continual improvement? (03)
(c) Write the impression of WTO about ISO. (03)
(d) Define Environmental Management System. (03)
(e) Discuss the key concepts & elements of Environmental Management Systems (EMS). (10)
(f) Explain whether companies need to be in 100% compliance in order to have an EMS? (03)

4. (a) Write down the main strategies of the "Environmental Conservation Act 1995". (05)
(b) What are the potential benefits of an EMS? (05)
(c) What types of issues should account for an environmental policy development? (05)
(d) What are the factors to be considered for aspects identification process? (05)
(e) Write down the environmental aspects identification procedure. (05)

5. (a) Which type of concerns have to be included in objective and targets fixation in an EMS process? (03)
(b) What are the purposes of an Environmental Management Program (EMP)? (04)
(c) What kind of information is normally included in an Environmental record? (05)
(d) Explain why a company need an emergency evacuation and response plan. What kinds of information have to be included in an emergency plan? (08)
(e) Discuss the issues that are considered in the management review process. (05)

The University of Asia Pacific
Department of Civil and Environmental Engineering
Final Examination, Spring 2004

Course # ECE 201
 Full Marks: 100.

Course Title: Basic Electrical Engineering
 Time: 2 hours

There are SEVEN questions in this section. Answer any FOUR.
Each question contains equal marks

1. Find the following parameters for the circuit shown below:
 - (a) the power consumption in z_1 , z_2 and z_3 .
 - (b) The total real power and reactive power consumption in the whole circuit.
 - (c) The power factor and the reactive factor.

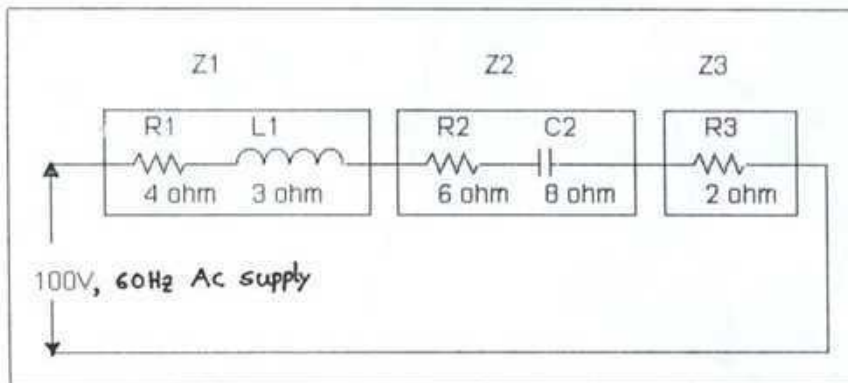

2. Derive the expressions for voltage, power, real power and reactive power (both for instantaneous and average value) for an R-L-C branch. Also draw their corresponding waveshapes.
3. (a) What is the significance of the RMS value of an alternating current wave?
 (b) Find the average value of the current wave shown below:

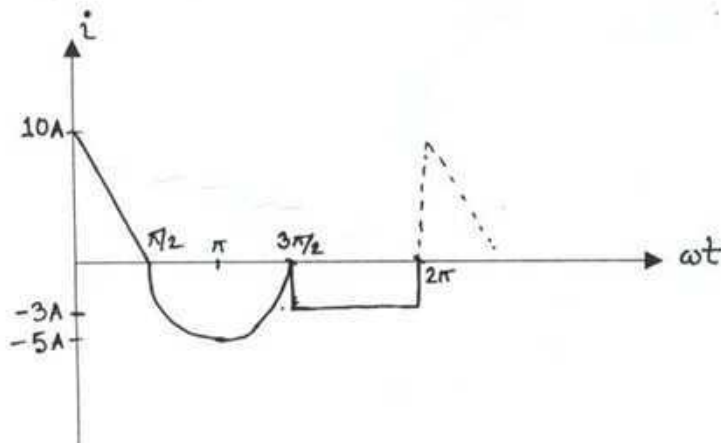

4. Find the following parameters for the wave shapes shown below:
- The phase difference between the two waves in **degree**.
 - If the following voltage wave is applied to a series circuit and the resulting current is found as i as shown below and one the elements of them is a capacitor of $100\mu\text{F}$. find the magnitude of other parameters.

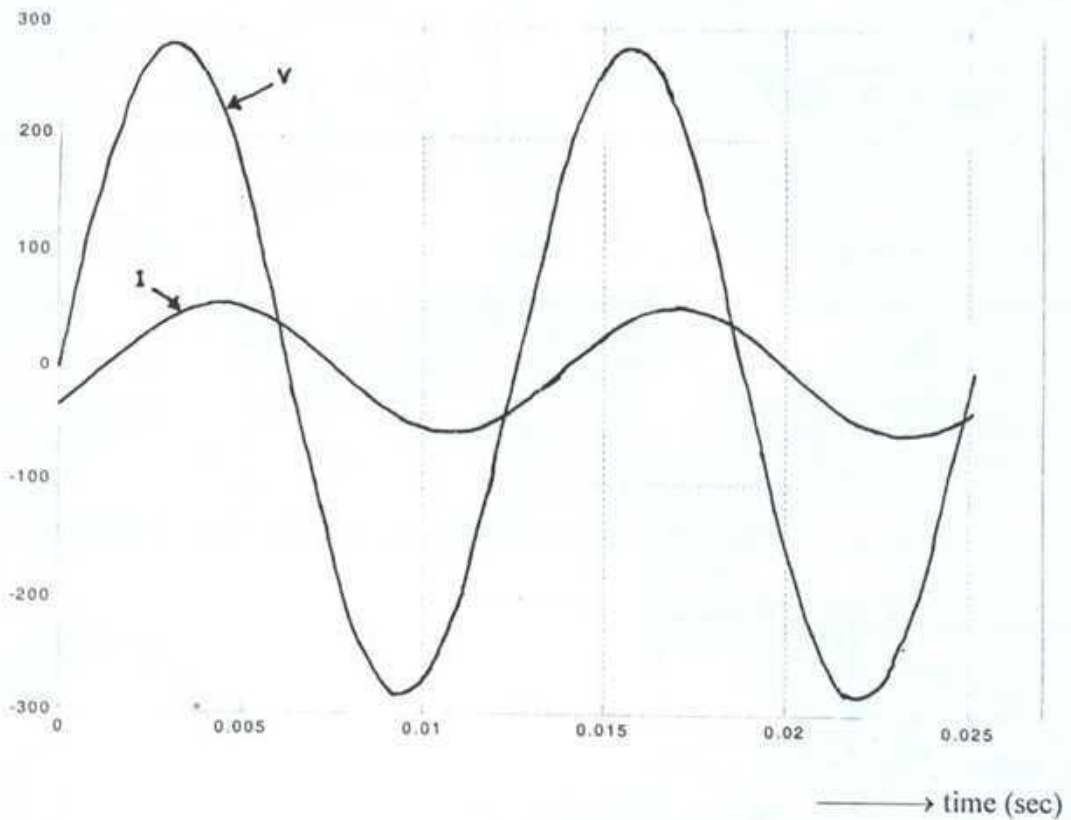

5. Find the current I_1, I_2, I_3, I_4 and I_5 from the following figure using KCL.

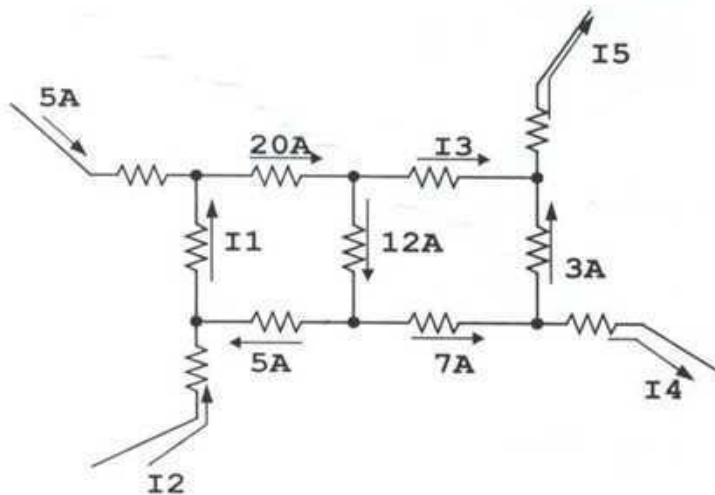

6. Find the voltage V_{ab} for the following circuits:

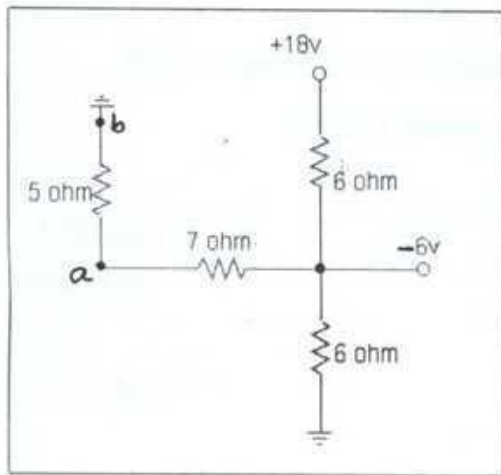

(a)

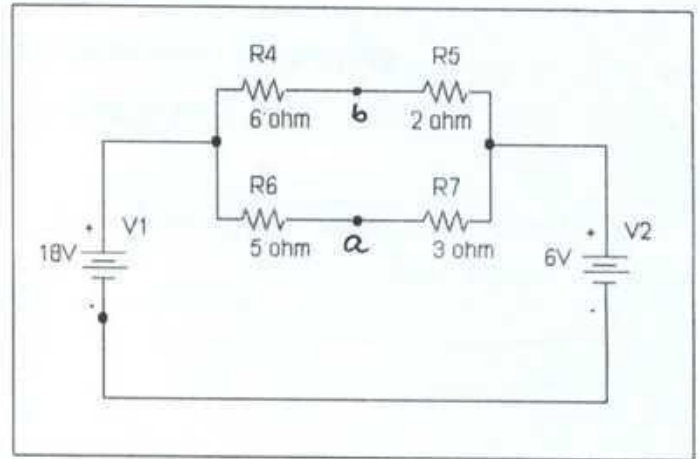

(b)

7. Find the Norton equivalent circuit for the following figure at the terminal a-b.

