

The University of Asia Pacific
Department of Civil Engineering
Final Examination Spring 2007

Course # CE 103
 Full Marks: 150

Course Title: Engineering Mechanics II
 Time: 3 Hours

There are SEVEN questions. Answer any SIX questions. The figures in the right margin indicate the marks of the questions.

- 1(a) Refer to the following figure. For the impending downward motion of B, determine (12)
 the tension in the cables and the weight of B. Weight of A = 400 lb, $f_A = 0.33$, $f_B = 0.25$.

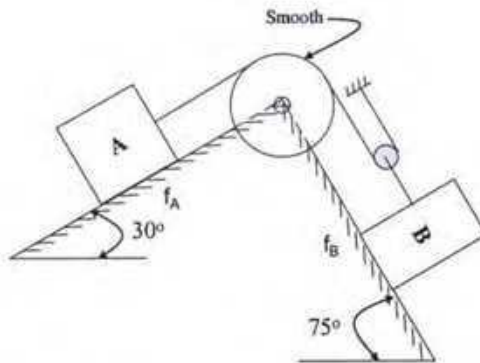

- 1(b) Refer to the following figure. If $Q = 150$ lb, friction coefficient for the band brake = (13)
 0.33 , friction coefficient for the bearing = 0.12 , weight of the 6 in shaft = 800 lb,
 weight of the 6 ft drum = 3000 lb, weight of the 8 ft brake wheel = 2400 lb,
 determine the weight W for impending motion considering the brake friction and the
 friction in bearing.

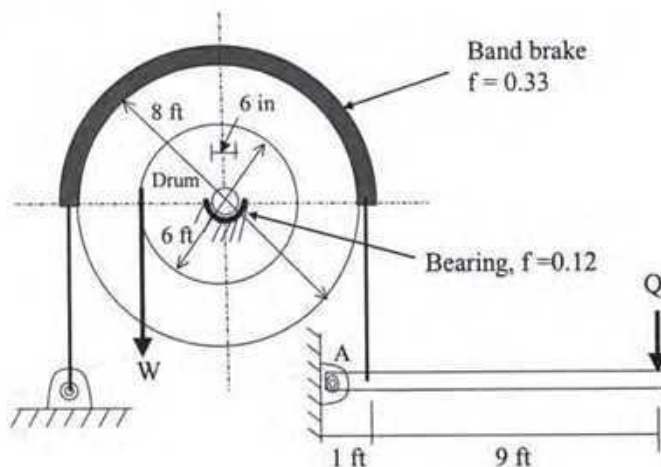

- 2(a) A particle is moving with rectilinear motion. The displacement (ft) versus time (sec.) function of the particle is given below: (12)

$$S = 2t^2 + 5t + 10$$

Determine the velocity, displacement, and acceleration of the particle after 5 sec. Also determine the displacement of the particle in 5th sec. Make comments on the velocity versus time function and acceleration versus time function.

- 2 (b) A body A, as shown in the following figure, is suspended from a cable wound around a 5-ft drum. The body is moving down with a constant acceleration of 3 fps². If the body starts to move from rest condition, determine the followings at points X and Y after 10 sec: (13)

- I. Angular and linear velocities
- II. Normal and tangential accelerations

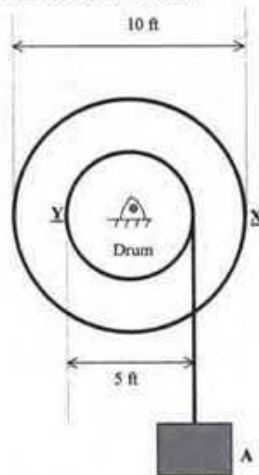

- 3(a) Refer to the following figure. All forces are in z direction. Determine the magnitude and location of the resultant force. (13)

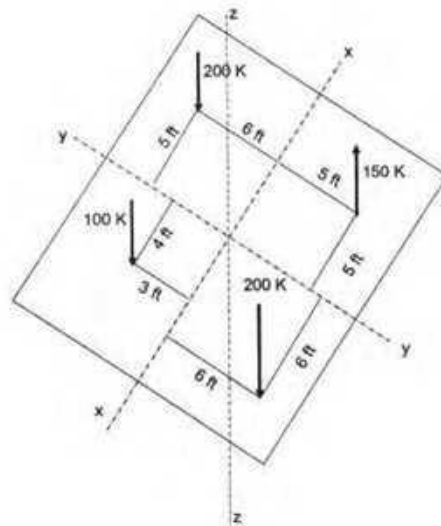

- 3(b) The sliding members A and B of the following figure are considered to move all times in the "y" and "x" directions, respectively. They are connected by the rod AB whose length is 10 ft. At the instant when $x = 8$ ft, velocity of B is 20 fps toward the right and acceleration of B is -15 fps^2 toward the left. Determine the velocity and acceleration of A at this instant. (12)

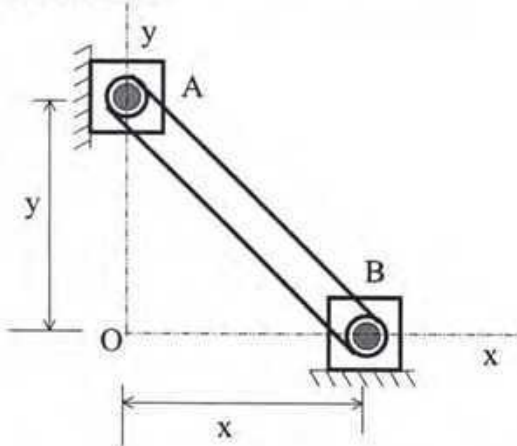

- 4(a) A cylindrical jet of water 4 inch in diameter moving with an absolute velocity of 30 fps, strikes a flat plate whose surface is at right angle to the jet as shown in the following figure. Determine the forces exerted on the plate by the water for the following conditions: (13)
- (i) the plate is fixed ($V_p = 0$)
 - (ii) the plate moves at $V_p = 8$ fps in the same sense as the water
 - (iii) the plate moves at $V_p = 8$ fps in the opposite sense to that of the water.

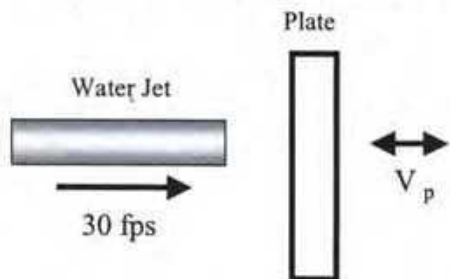

- 4(b) In the following figure $W_A = 1000 \text{ lb.}$, $f = 1/3$ and the pulleys C and D are to be considered frictionless and weightless. (a) If A moves 60 ft. from rest up the incline in 12 sec., what is the weight W_B of the body B? (b) What are the forces in the cables attached to A and B? (c) What is the change of potential energy of A and B? (12)

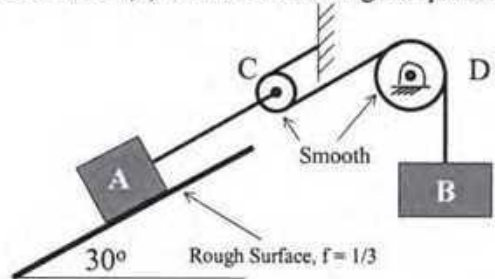

- 5(a) Refer to the following figure. The speed of A changes from 10 fps to 60 fps during 25 sec. Determine (i) the weight of B, (ii) the distance moved by B during 25 sec, and (iii) the tension in the cable. (13)

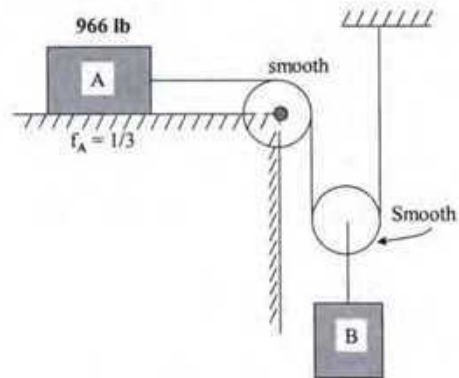

- 5(b) Derive the following relationship for kinetic energy (KE) of a body in plane motion: (12)

$$KE = \frac{mv_o^2}{2} + \frac{I_o \omega^2}{2} + v_o \omega m \bar{y}$$

The symbols carry the usual meanings.

- 6(a) In the following figure, $W_A = 200$ lb., $W_B = 100$ lb., $f_A = 1/4$, and $f_B = 1/3$. How far and in what direction does A travel from rest during 30 sec.? What are the tensions in the cables C and D? (12)

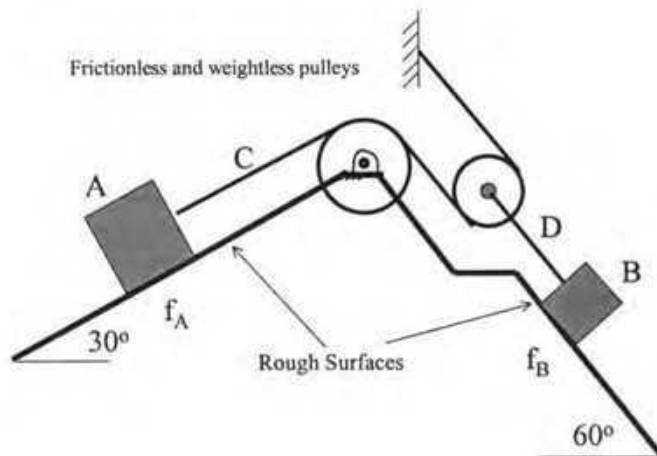

- 6(b) Derive an expression for the moment of inertia of a homogeneous right circular cylinder about the geometric axis and a axis perpendicular to the geometric axis passing through the base of the cylinder. (13)

If a cast iron cylinder is 24 inch in diameter and 48 inch in long, what is its moment of inertia and radius of gyration about the axis perpendicular to the geometric axis passing through the base? Unit weight of the cast iron = 450 lb/ft^3 .

- 7(a) A 3-ft solid disk A of weight 128.8 lb is supported by a weightless cord, which wraps about its midsection as shown in the following figure. If it rolls downward from rest, what is its angular velocity after 5 sec? Determine the tension in the cord and the acceleration of A at center. (12)

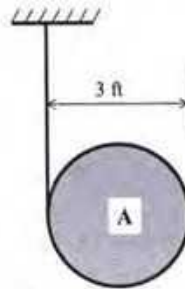

- 7(b) The following figure represents a boom that supports a load $W = 1000 \text{ lb}$. If $AB = BC = 6 \text{ ft}$, $BD = 5 \text{ ft}$, and $BE = 4 \text{ ft}$, find the tension in the cable and the force in members AE and CE. (13)

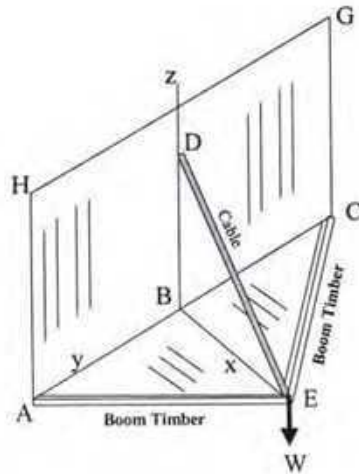

5. Project engineer of Mr. Rahman has calculated the following estimate for his proposed 2500 Sft construction work:

RCC casting	: 2000 Cft
Reinforcement	: 10 tons
5 inch brick work	: 3000 Sft
Plaster work	: 25000 Sft
Mosaic and Tiles work	: Tk.2,00,000.00 (Lump sum)
Door, windows etc	: Tk. 2,50,000.00 (Lump sum)

Also assume,

Electrification Cost (With Labor)	: 9% of the building construction cost
Sanitary (With Labor)	: 10% of the building construction cost
Contingency Charge	: 5% of the total construction cost

Assuming reasonable unit price calculate the amount required per square foot of the above-mentioned building.

6. Mr. Rahman wants to use some equipment in his construction work. But he knows that using of these equipments have both merits and demerits. Write down some merits and demerits of using equipments in the construction projects.
7. Give the specific regulation of the RAJUK rules regarding the following situation,
 - a. Distance of a building from the adjacent road.
 - b. Height of a building from the adjacent road.
8. Give the special regulations of RAJUK regarding site clearance for Residential Buildings.
9. Describe the Road transportation network in Bangladesh.
10. Write a short note on seven physiographical divisions of Bangladesh.

7

The University of Asia Pacific
Department of Civil Engineering
Final Examination Spring 2007

Course # CHEM 111
Full Marks: 50

Course Title: Chemistry
Time: 3 hours

[Answer any FOUR questions. All questions carry equal marks]

1. (a) What is an atom according to Dalton's theory? 02
(b) Discuss the Rutherford solar system atom model. 03
(c) What are the limitations of Rutherford's atomic theory? 02
(d) What are the postulates of Bohr's atomic theory?
Mention the success and failure of Bohr's theory. 5.5
2. (a) What is dynamic equilibrium?
Give some examples of chemical and physical equilibria. 05
(b) The formation of ammonia by Haber Bosch process follows the following equilibrium reaction:
$$\text{N}_2(\text{g}) + 3\text{H}_2(\text{g}) \rightleftharpoons 2\text{NH}_3 + 92 \text{ kJ mol}^{-1}$$

What will be the effect of increase in pressure and decrease in temperature on this equilibrium? 04
(c) What is K_p ?
Find an expression for K_p of this equilibrium.
What will be its K_c ? 3.5
3. (a) What are enthalpy and enthalpy change?
Explain exothermic and endothermic reactions with suitable examples. 04
(b) What is standard enthalpy of formation?
Define standard enthalpy of neutralization. 03
(c) What is combustion?
Calculate the standard enthalpy of formation of benzene from the following data:
- | Substance | Formula | $\Delta H_c / \text{kJ mol}^{-1}$ |
|-----------|----------------------------------|-----------------------------------|
| Benzene | $\text{C}_6\text{H}_6(\text{l})$ | -3278 |
| Carbon | C (graphite) | -394 |
| Hydrogen | $\text{H}_2(\text{g})$ | -286 |
- 5.5

The University of Asia Pacific
Department of Civil Engineering
Final Examination Spring 2007

Course# CE 205
 Full Marks: 100 (=10 X 10)

Course Title: Numerical Analysis and Computer Programming
 Time: 3 hours

There are **Twelve (12)** questions, Answer any **Ten (10)**

Q1. By using Newton-Raphson's method, find the root of $x^4 - x - 10$ which is near to $x=2$, correct to three places of decimal.

Q2. Solve the following linear equations by Gauss-Jordan Elimination method

$$\begin{aligned} x + 2y + z &= 8 \\ 2x + 3y + 4z &= 20 \\ 4x + 3y + 2z &= 16 \end{aligned}$$

Q3. Evaluate $\int_0^6 (1+x^2)^{-1} dx$

by using (a) Simpson's '1/3' rule, (b) Simpson's '3/8' rule.

Q4. Using Taylor's series, find the solution of the differential equation $y' = y^2$, $y(0) = 1$ at $x = 0.01$.

Q5. Using Newton's divided difference method calculate $f'(5)$ for the following data

x	0	2	3	4	7	9
f(x)	4	26	58	112	466	922

Q6. Derive the best-fit equation $y = a_1x + a_2x^2$ for the points (0,0), (2,3), (3,5), (4,6) and (5,7).

Q7. Calculate the shaded portion of the area under the curve as shown in the following figure-1, using Gauss Integration for $n=3$.

n	$\pm \xi_i$	w_i
1	0.0	2.0
2	± 0.57735	1.0
3	± 0.77460	0.55556
	0.0	0.88889

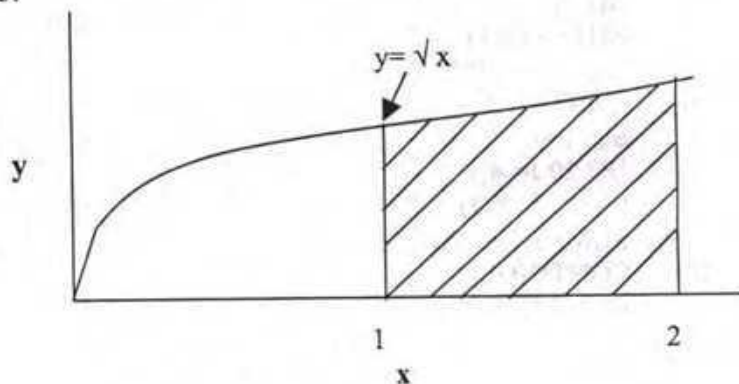

Figure-1

Q11. Write a FORTRAN program to

- (a) Read an integer N
- (b) Read the magnitudes $F(k)$ of N forces [$k=1$ to N], the angles $\theta(k)$ they make with the horizontal and their perpendicular distances $r(k)$ from a reference point O
- (c) Calculate the horizontal component [$F_x=F(k)\cos\theta(k)$], vertical component [$F_y=F(k)\sin\theta(k)$] and moment about O [$M_o=F(k)r(k)$] for each force and also calculate $\sum F_x$, $\sum F_y$ and $\sum M_o$
- (d) Write 'The forces are in equilibrium' if $\sum F_x=0$, $\sum F_y=0$, $\sum M_o=0$, otherwise write the values of $\sum F_x$, $\sum F_y$ and $\sum M_o$.

Q12. Write a program to perform the shear design of rectangular RC sections by the Working Stress Method using the following procedure. The units used for the calculations are kips, ksi, inch etc.

1. Read material properties f_c , f_s
2. Read sectional properties b, d, A_s
3. Calculate $V_{c(max)} = 5\sqrt{f_c} bd$
4. Read design shear force V
5. (i) If $V > V_{c(max)}$, print 'Change the cross-section'
- (ii) Otherwise, calculate $V_c = 1.1\sqrt{f_c} bd$, design spacing, $S_{(req)} = A_s f_s d / (V - V_c)$, $V_{c0} = 3\sqrt{f_c} bd$
 - (a) If $V > V_{c0}$, the stirrup spacing (S) should be the minimum of $S_{(req)}$, $d/4$, 12", $A_s/0.0015b$
 - (b) If $V < V_{c0}$, but $V > V_c$, S should be the minimum of $S_{(req)}$, $d/2$, 24" $A_s/0.0015b$
 - (c) If $V < V_c$, S should be the minimum of $d/2$, 24" and $A_s/0.0015b$Print S, A_s

- Q8. An airplane lost its control and is moving towards a 103 storey building as shown in figure 2. The plane is maintaining a constant height of 900 ft above ground level. To destroy the plane before it reaches the building, a missile launcher is set at the base of the building. The alignment of the launcher is set such that the missile will follow a curved path defined by $y(x) = x^3 + 3x^2 + 10$. Using interval bisection method, find the distance of the possible point of collision from the base of the building.
 [Take 7 and 10 as initial and final points respectively and tolerance 0.5]

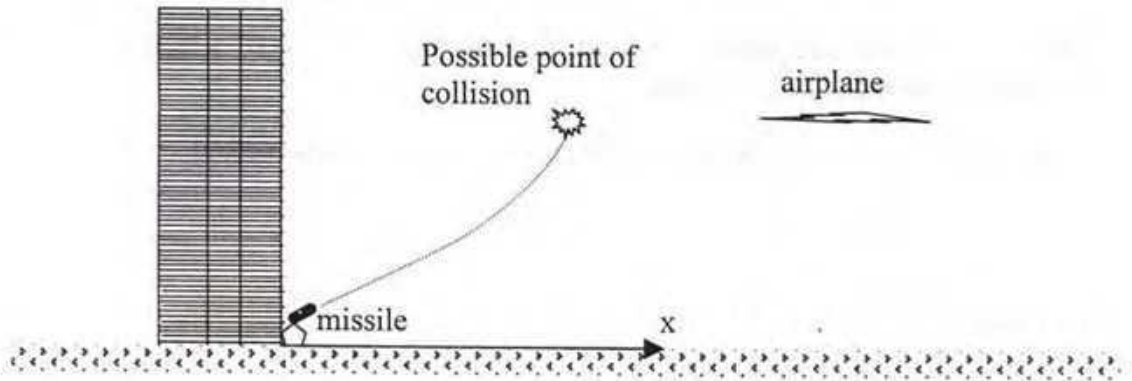

Figure-2

- Q9. In a laboratory test the following strength for concrete cylinder is obtained at different time intervals:

Days:	4	11	18	24	31	38
Strength (ksi):	0.6	1.4	2.4	3.0	3.3	3.5

Calculate the value of the 14th day concrete strength using Lagrange's Polynomial Interpolation.

- Q10. Find the output of the following program

```

DIMENSION X(-4:4)
INTEGER X, SUM
DO 10 I= -3, 0, 3
X(I-1) = - (2*I-1)
X(I) = - (I+1)
X(I+1) = - (I**3-1)
10 CONTINUE
SUM=0
DO 20 J=-4,4
PRINT*, X(J)
SUM=SUM+ X(J)
20 CONTINUE
PRINT*, 'SUM=', SUM
STOP
END
    
```

The University of Asia Pacific
 Department of Civil Engineering
 Final Examination Spring 2007

Course # : CE 211
 Full Marks: 100

Course Title: Mechanics of Solids I
 Time : 3 hrs

There are **Thirteen (13)** questions in this paper. Answer any **Ten (10)**.
 Assume any missing data reasonably

Q1. Determine the reactions for the frame, loaded as shown in Fig.1. Also find the shear force, axial force and bending moment at section a-a. (10)

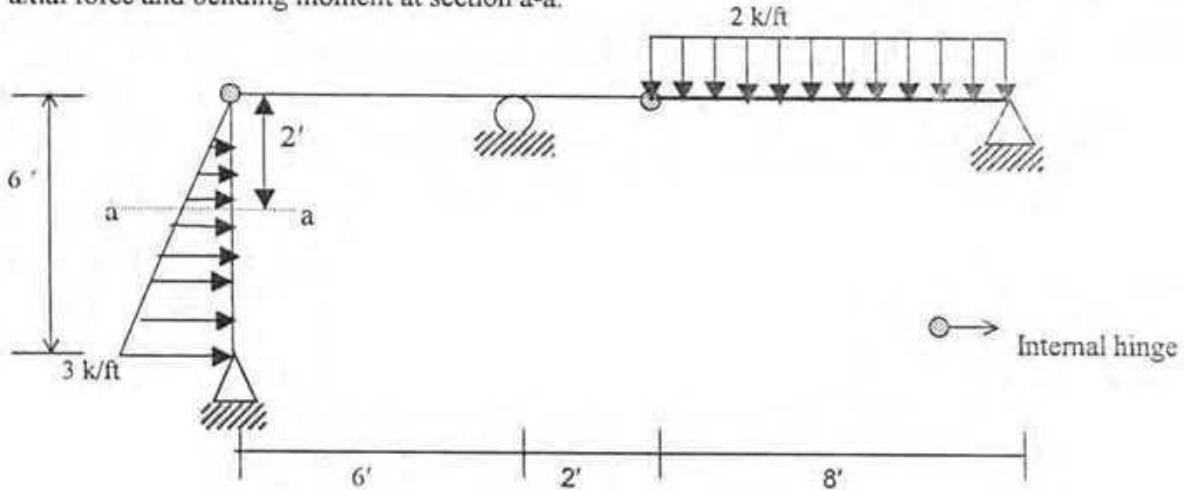

Fig.1

Q2. Using summation procedure, draw the shear force and bending moment diagram for the beam with loads as shown in Fig. 2. (10)

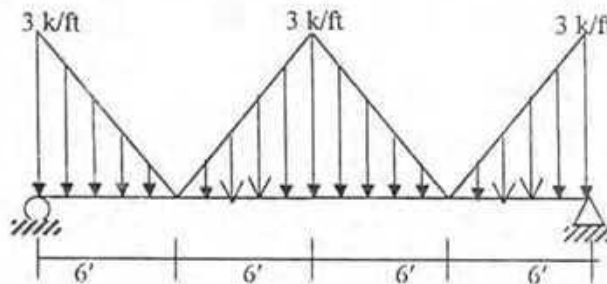

Fig.2

Q3. Using singularity function, derive equations of shear force and bending moment of each region for the beam as loaded in Fig. 3. (10)

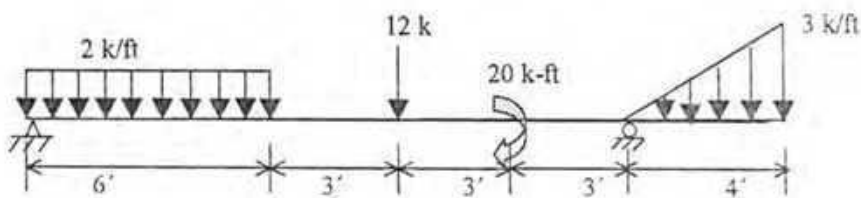

Fig.3

Q4. A solid cylinder of 5 cm diameter and 100 cm length is subjected to a tensile force of 16 tons. One part of this cylinder, L_1 in length is of steel, the other part, fastened to steel, is aluminum and is L_2 long.

(i) Determine the lengths L_1 and L_2 so that the aluminum part elongates twice as much as the steel portion. (5)

(ii) Compute the elongation of each material part and hence the total deformation (3)

(iii) What stress is developed in the cylinder? (2)

Assume, $E_{al} = 70 \times 10^4 \text{ kg/cm}^2$ and
 $E_s = 21 \times 10^5 \text{ kg/cm}^2$

Q5. A $6'' \times 10''$ timber beam is reinforced only at the bottom by a steel plate, as shown in the Fig. 4. The beam is loaded in a 18' simply supported span. If $E_s = 20E_w$, $\sigma_s \leq 18 \text{ ksi}$ and $\sigma_w \leq 1.2 \text{ ksi}$, find the value of P. (10)

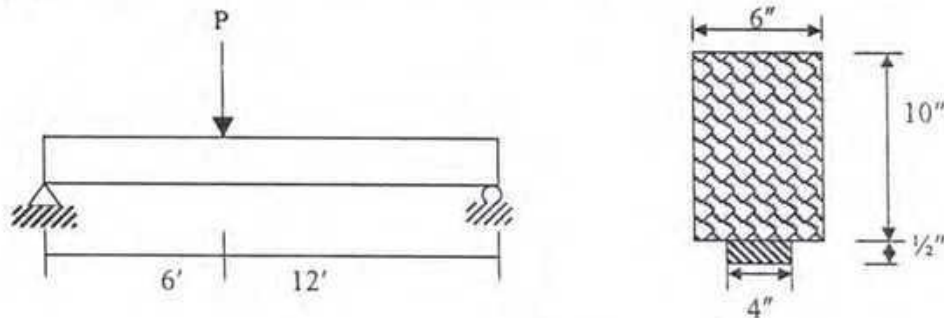

Fig. 4

Q6. A simply supported beam of 10 ft span is loaded as shown in Fig.5. The beam has a constant width of 6" throughout its length with varying depth of 9" at the center to minimum at ends. Find the minimum depth of the beam at Sec. 1-1 such that the maximum bending stress at Sec.1-1, $\sigma_{\max(1-1)}$ is equal to that at the mid span section, $\sigma_{\max(\text{midspan})}$. (10)

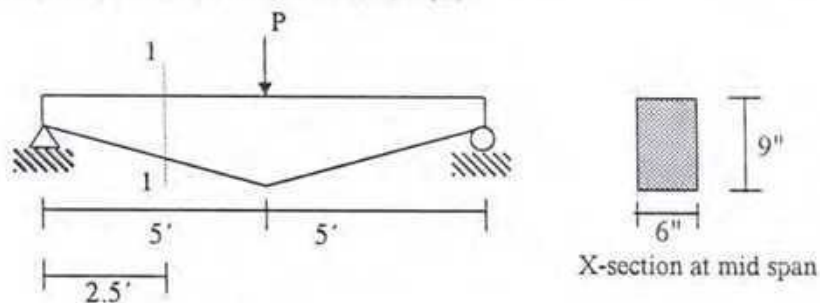

Fig. 5

Q7 (a). A uniformly distributed load of 200 lb/ft is carried on a simply supported span. If the cross section is as shown in Fig. 6(a), determine the maximum length of the beam if the shearing stress is limited to 100 psi. Assume that load acts over the entire length of the beam. (5)

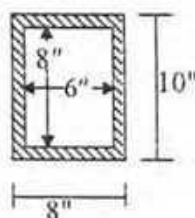

Fig. 6(a)

Q7 (b). Find the ratio of maximum shear stress to average shear stress of the beam section shown in Fig. 6(b). (5)

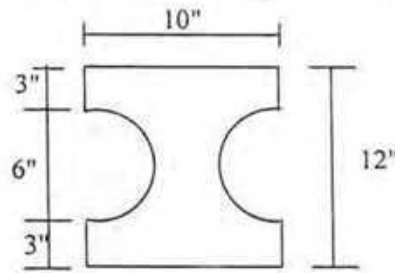

Fig. 6(b)

Q8. Determine the minimum cross-sectional areas of members BC, BD and CE for the truss shown in Fig. 7 if the stresses are not to exceed 20 ksi in tension or 14 ksi in compression. (10)

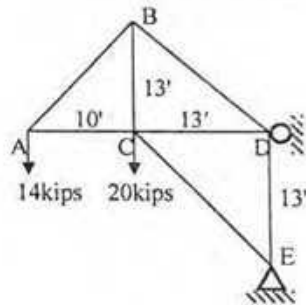

Fig. 7

Q9. Determine the location of the shear center of a thin-walled section shown in Fig. 8. The thickness t is constant throughout the section. (10)

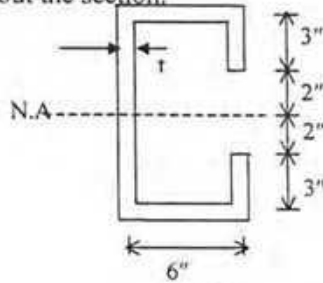

Fig. 8

Q10. Two plates are joined by four rivets 22 mm in diameter as shown in Fig. 9. Find the allowable load P if the allowable stresses are as follows: (10)

allowable shearing stress, $\tau = 80$ MPa

allowable bearing stress, $\sigma_b = 120$ MPa

allowable tensile stress, $\sigma_t = 90$ MPa

Assume 3 mm clearance for the hole diameter over the actual bolt diameter.

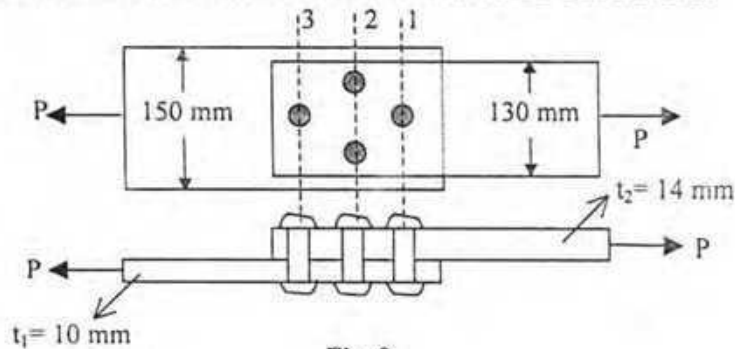

Fig. 9

Q11. In the gusset plate connection shown in Fig.10, each rivet has a X-sectional area of 0.50 in^2 . The allowable load P was designed for a shearing stress of 10 ksi . What will be the maximum shearing stress in the rivets if the rivet at A is improperly driven so that it cannot carry any load? (10)

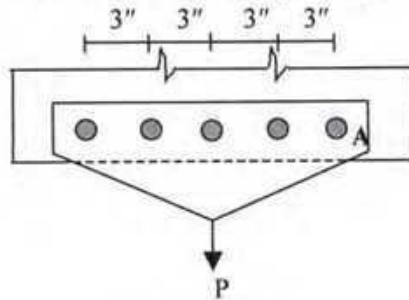

Fig. 10

Q12. A plate is lapped over and welded to a gusset plate as shown in Fig.11. What maximum value of P can be applied as shown if $5/16$ -in. fillet welds are used using allowable $\tau = 21 \text{ ksi}$ through the throats. (10)

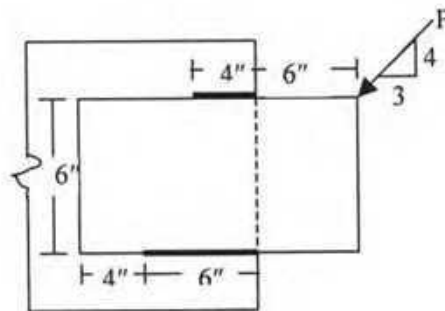

Fig. 11

Q13. Two $4 \times 4 \times 3/8$ in. angles, which are to be welded to a gusset plate of thickness 0.5 inch carries a load of 220 kips applied along its centroidal axis as shown in Fig.12. Determine the lengths of fillet welds applied along the toe, heel and entire length of the end of the angle for a non-eccentric connection. Assume that allowable shearing stress through the throat of each weld is 21 ksi . (10)

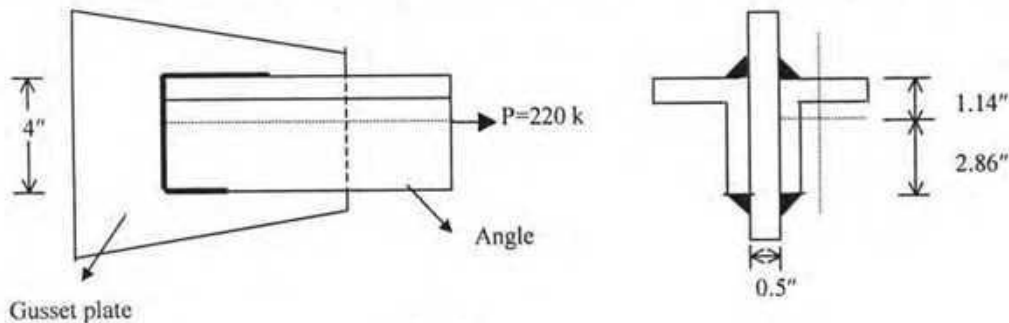

Fig. 12

Fillet weld size

Thickness of the parts to be welded, (in)	Minimum fillet weld size, in	Maximum fillet weld size, in
$1/4$ inch or less	$1/8$ inch	Thickness of the parts
Over $1/4$ to $1/2$	$3/16$ inch	$1/16$ inch less than the thickness of the parts
Over $1/2$ to $3/4$	$1/4$ inch	$1/16$ inch less than the thickness of the parts
Over $3/4$	$5/16$ inch	$1/16$ inch less than the thickness of the parts

The University of Asia Pacific
Department of Civil Engineering
Final Examination Spring 2007

Course No : CE 221
 Full Marks : 150

Course Title: Fluid Mechanics
 Time : 3.0 hours

Answer any 6 (SIX) questions. Figures in the right margin indicate full marks.

- 1 a. Define, Viscosity, Surface Tension, and Capillarity. 6
- b. Differentiate between, (i) Lagrangian Method and Eulerian Method 6
 (ii) Ideal and Real Fluid
 (iii) Uniform and Non-Uniform Flow
- c. A space of 3.0 cm between two large plane surfaces is filled with glycerine. 8
 Determine the force required to drag vertically a very thin plate 0.90 m^2 in area between the plane surfaces at a constant speed of 1 m/s, if the plate is at a distance of 1.25 cm from one of the surfaces. Take dynamic viscosity $0.05 \text{ N}\cdot\text{s}/\text{m}^2$ and weight of the plate 5 N.

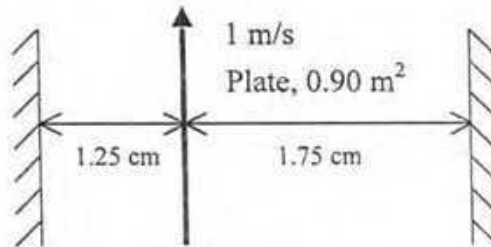

Figure 1

- d. By how much does the pressure in a cylindrical jet of water 5 mm in diameter exceed the pressure of the surrounding atmosphere if the surface tension of water is $0.073 \text{ N}/\text{m}$. 5
- 2 a. What is continuity equation? Derive the equation for incompressible fluid. 10
- b. Compute "y" in Figure 2 if the pressure differences between points A and B is $135.38 \text{ kN}/\text{m}^2$. ($P_A > P_B$) 7

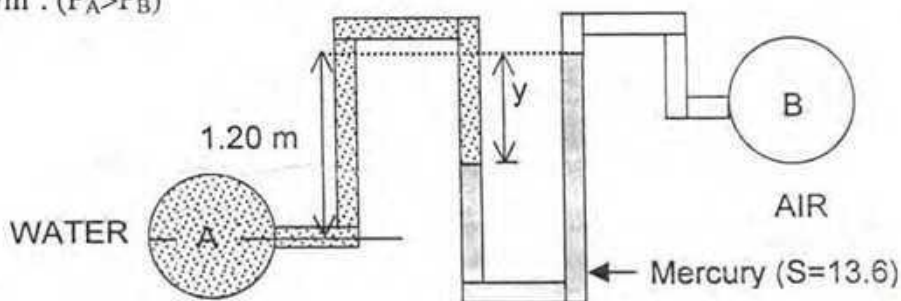

Figure 2



c. Determine the reading of gauge A in Figure 3.

8

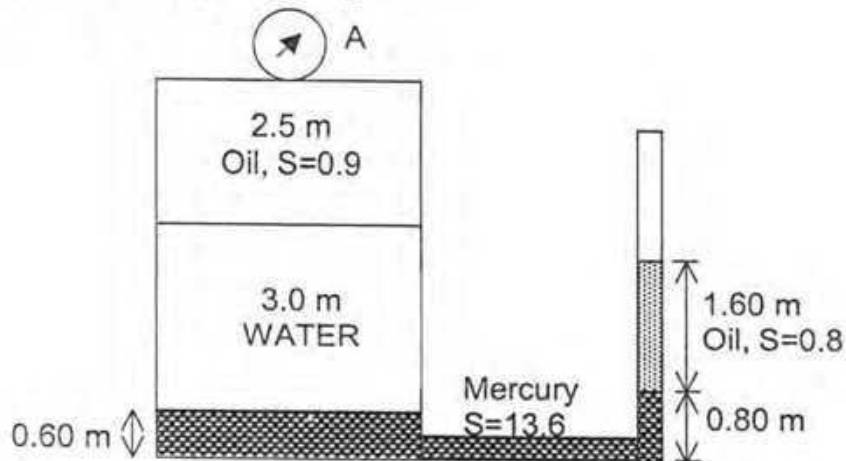

Figure 3

- 3 a. State and derive Bernoulli equation as an energy equation, mentioning clearly the assumptions made in the derivation. What are its limitations? 8
- b. What are the advantages of the impulse-momentum equation over the Bernoulli equation? Give two applications of the theorem. 5
- c. Water enters in a 120° horizontal reducing pipe with a velocity of 5 m/sec and a pressure of 78.480 kN/m^2 as shown in Figure 4. If the diameters at the entrance and exit sections are 30 cm and 20 cm respectively, calculate the components of the reaction e.g. R_x and R_y acting on the pipe. 12

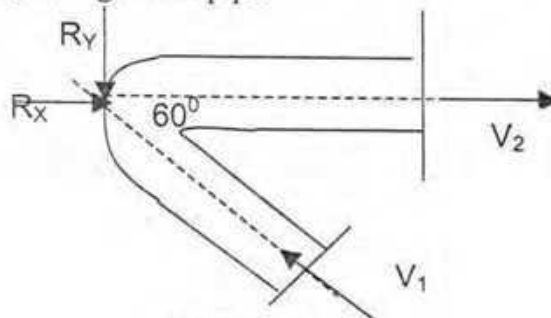

Figure 4

- 4 a. What do you understand by the term 'centre of pressure'? 5
- b. Calculate the total pressure and the depth of the center of pressure on the inclined gate AB shown in Figure 5, the width of the gate perpendicular to the plane of paper is one metre. 8

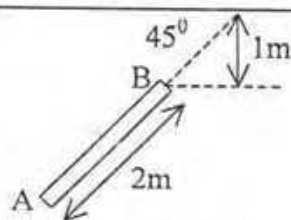

Figure 5

- c. A pitot tube having a coefficient of 0.98 is used to measure the velocity of water at the center of the pipe. Calculate the velocity when the stagnation pressure and static pressure are 6m and 5 m respectively. 5
- d. Water flows through a horizontal venturimeter, 30 cm x 15 cm diameter, at the rate of 0.039 cumecs. If the difference of pressure is 0.25 m of water, calculate the coefficient of the venturimeter. 7
- 5 a. Define, (i) coefficient of contraction
(ii) coefficient of velocity, and
(iii) coefficient of discharge 6
- b. A circular orifice, 3.5 cm diameter, is made in the vertical wall of a tank. The jet falls vertically through 0.5 m while moving horizontally through a distance of 1.5 m. Calculate the coefficient of velocity if the head causing flow is 1.2 meters. If the discharge is $2.80 \times 10^{-3} \text{ m}^3/\text{s}$, Calculate C_c and C_d . 5
- c. Show that the discharge equation of an external mouth piece can be expressed as,
 $Q = 0.855 a \sqrt{2gH}$ 9
- d. Water is discharging through an external mouthpiece of 25 cm^2 area, under a head of 3m. Find the discharge through the mouthpiece. Take $C_c=0.62$. 5
- 6 a. What is the difference between a weir and an orifice? How are the weirs classified? 6
- b. A rectangular channel 1.25 m wide has a rectangular weir at the end. If the length of the weir is 1 m, and its sill is 0.2 m from the bottom, find the discharge when the measured head over the crest is 0.25 m. Take $C_d=0.62$. 8
- c. Show that the flow over a triangular notch can be expressed as, $Q = \frac{8}{15} C_d \sqrt{2g} \tan \frac{\theta}{2} H^{\frac{3}{2}}$ 7
- d. The rate of flow of water over a V-notch with apex angle $\theta = 60^\circ$ is 0.05 cumecs. Find the head over the crest if $C_d = 0.62$. 4
- 7 a. What is Dimensional analysis? What are the different applications of the principles of Dimensional homogeneity in fluid mechanics? 6
- b. Check whether the following equations are dimensionally homogenous: 9
- a. $Q = C_d a \sqrt{2gH}$ b. $V = C \sqrt{RS}$ c. $h_f = f \frac{L V^2}{D 2g}$
- c. Two reservoirs A & B shown in Figure 6 are connected by a pipe line consisting of two pipes, one of 15 cm diameter and length 6m and the other of diameter 30 cm and 16 m length. If the difference of water levels in the two reservoirs is 6 m, calculate the discharge. Take $f=0.04$ 10

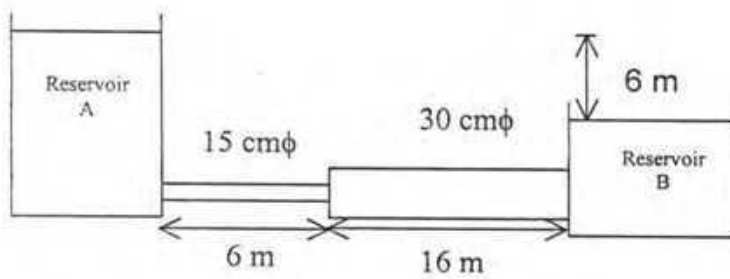

Figure 6

- 8 a. What do you understand by 'minor losses' in pipes? Mention the places with neat sketches where minor losses may occur. 6
- b. Calculate the discharge through the pipeline shown in the Figure 7. Also find the pressure at points A and B. The depth of water in the reservoir is 5 m. Neglect losses. 12

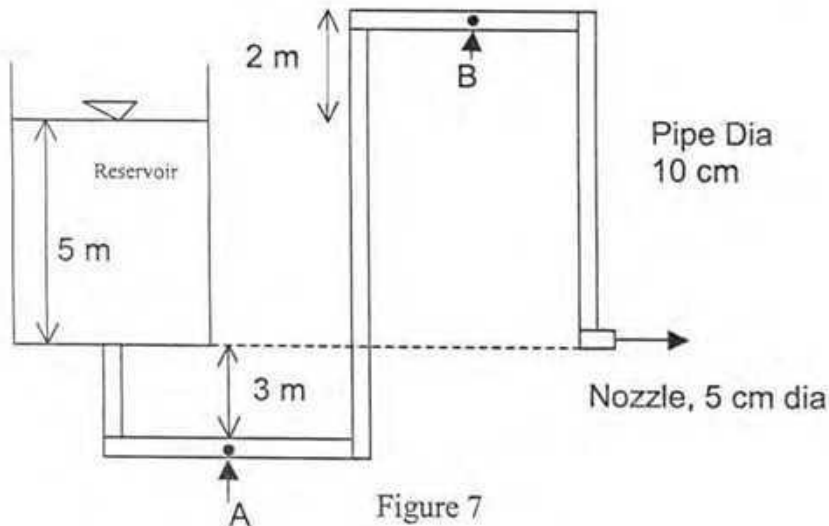

Figure 7

- c. Water is flowing through a pipe. The energy grade line is shown in Figure 8. Calculate flow of water through the pipe. Take $f=0.04$. 7

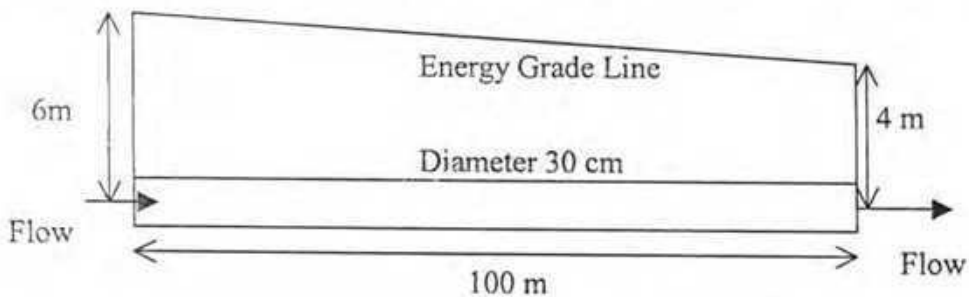

Figure 8

The University of Asia Pacific
Department of Civil Engineering
Final Examination Spring 2007

Course # CE 313
 Full Marks: 100 (= 10 × 10)

Course Title: Structural Analysis & Design II
 Time: 3 hours

[Answer any 10 (ten) of the following 14 questions]

- The side elevation of a two-storied residential RCC structure is shown in the figure below. Calculate
 - the story forces F_1 , F_2 and the base shear due to wind force if the average wind coefficients are $C_1 = 1.0$, $C_2 = 1.0$, $C_G = 1.2$, $C_t = 1.0$, $C_p = 1.1$, frame width = 15', basic wind velocity = 120 mph,
 - the seismic zone coefficient Z if the seismic base shear is equal to the base shear due to wind [Given: $R = 4.0$, $I = 1.0$, $S = 1.2$, weight of each beam = 1.5 k/ft].

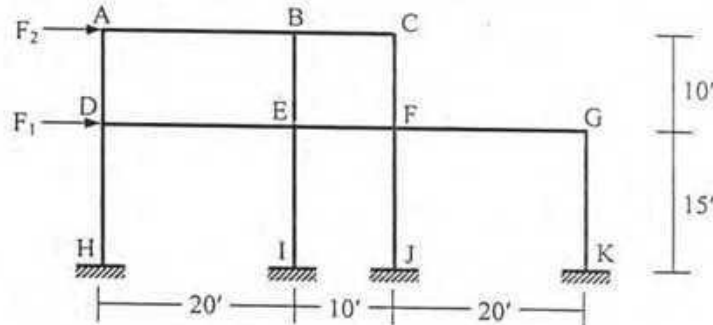

- For the structure described in Question 1, use the Portal Method to calculate the lateral loads F_1 , F_2 if the axial forces in beams AB and DE are 10 kips and 15 kips respectively.
- For the structure described in Question 1, use the Cantilever Method to calculate the lateral loads F_1 , F_2 if the shear forces in beams AB and DE are 10 kips and 15 kips respectively. Assume all the columns have the same cross-sectional area.
- For a uniformly distributed vertical load of 1.5 k/ft on each beam, draw the SFD and BMD of beams DE, EF and AFD and BMD of columns DH and EI of the structure described in Question 1, using
 - approximate locations of inflection points, (ii) ACI coefficients.
- In the structure shown below,
 - Use the Portal Method to calculate the reactions at support A, G and draw the BMD of ABC.
 - Calculate the forces in members CD, BE, CF, assuming diagonal members to take tension only.

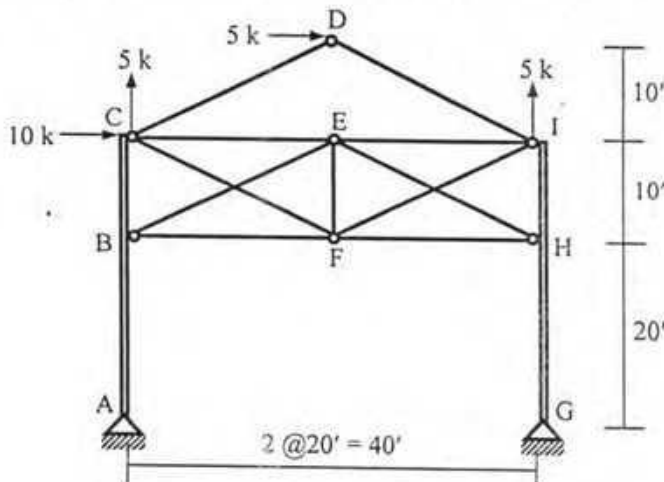

11. Use the Flexibility Method (considering flexural deformations only) to draw the bending moment diagram of the beam shown below if in addition to the applied load, support D rotates 1° clockwise [Given: $EI = 40 \times 10^3 \text{ k-ft}^2$].

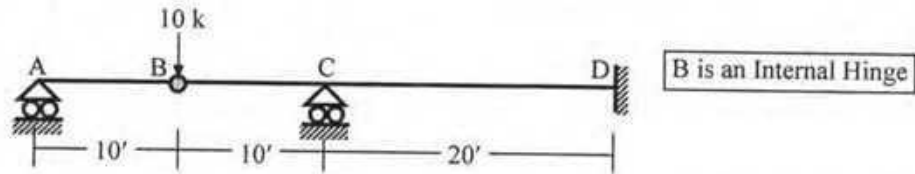

12. Use the Flexibility Method (considering flexural deformations only) to draw the bending moment diagram of the frame shown below, if in addition to the applied load, support D settles $0.10'$ downward [Given: $EI = 40 \times 10^3 \text{ k-ft}^2$].

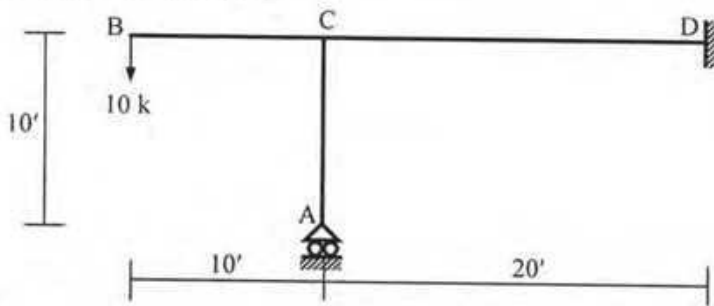

13. Use the Flexibility Method to calculate the forces in all the members of the truss shown below, if in addition to the applied load, support A moves $0.10'$ rightward [Given: $EA/L = \text{constant} = 1000 \text{ kip/ft}$].

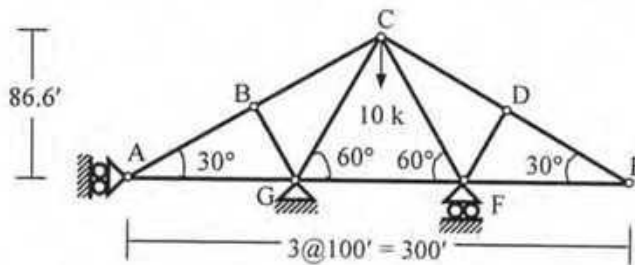

14. Calculate the support reaction Y_C and forces in members AC, BC and DC of the truss shown below.

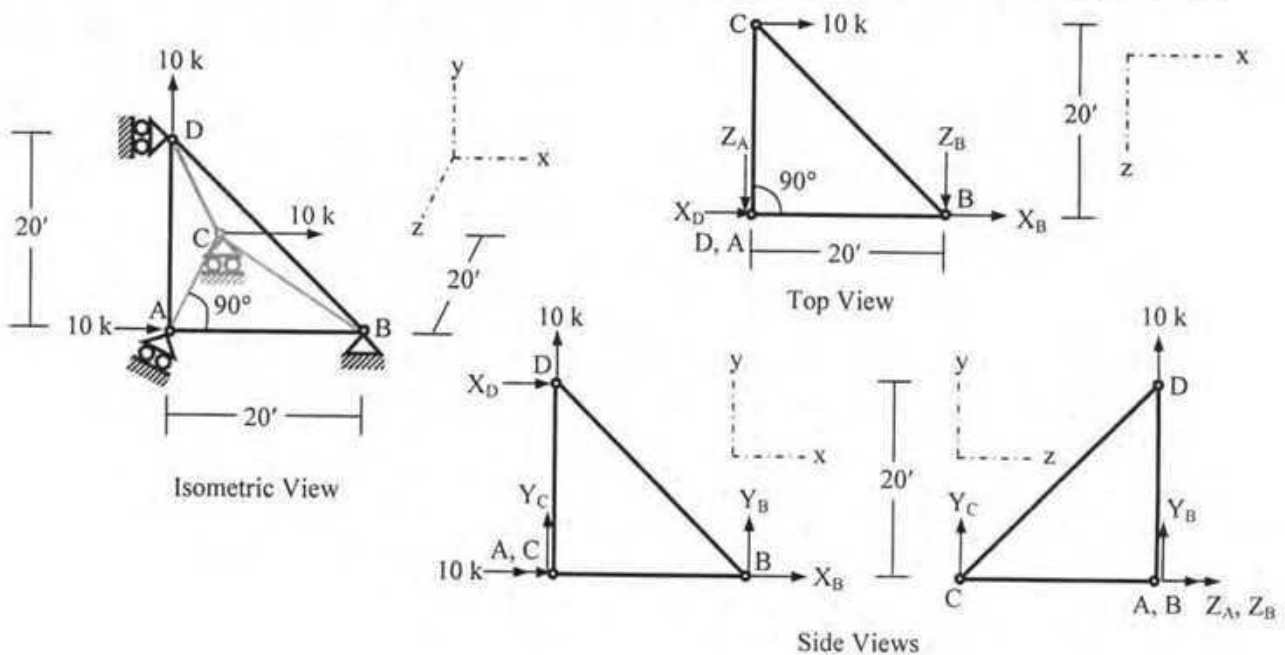



List of Useful Formulae for CE 313

- The design wind pressure at a height z is $p_z = 0.00256 C_1 C_2 C_G C_t C_p V_b^2$, design wind force $F_z = B h_{eff} p_z$
- The total design base shear is $V = (ZIC/R) W$
- $F_1 = 0.07 TV \leq 0.25V$ when $T > 0.7$ second, and $= 0$, when $T \leq 0.7$ second
- $F_j = (V - F_1) [w_j h_j / \sum w_i h_i]$
- Structural Period $T = C_1(h_n)^{3/4}$, where, $C_1 = 0.083$ for steel moment resisting frames, 0.073 for RC moment resisting frames and eccentric braced steel frames, 0.049 for all other structural systems
- Portal Method for multi-storied frames assumes
 - The shear force in an interior column is twice the shear force in an exterior column.
 - There is a point of inflection at the center of each column, and at the center of each beam.
- Cantilever Method is based on three assumptions
 - The axial force in each column of a story is proportional to its horizontal distance from the center of gravity of all the columns of the story.
 - There is a point of inflection at the center of each column, and at the center of each beam.
- Vertical Analysis based on approximate location of hinges
 - $M_{(+)} = 0.08 wL^2$, $M_{(-)} = 0.045 wL^2$,
 - $V_{(+)} = wL/2$, and $V_{(-)} = -wL/2$
- Vertical Analysis using ACI Coefficients
 - $M_{(+)}$ (i) For end spans, if discontinuous end is (a) unrestrained $= wL^2/11$, (b) restrained $= wL^2/14$
 - (ii) For interior spans $= wL^2/16$
 - $M_{(-)}$ (i) At the exterior face of first interior supports for (a) Two spans $= wL^2/9$, (b) More spans $= wL^2/10$
 - (ii) At the other faces of interior supports $= wL^2/11$
 - (iii) For spans not exceeding $10'$, of where columns are much stiffer than beams $= wL^2/12$
 - (iv) At the interior faces of exterior supports, if the support is (a) a beam $= wL^2/24$, (b) a column $= wL^2/16$
 - V (i) In end members at first interior support $= \pm 1.15wL/2$, (ii) At all other supports $= \pm wL/2$
- Deflection of truss due to load, temperature change and misfit, $\Delta = \sum N_1 dL = \sum N_1 (N_0 L / EA + \alpha \Delta T L + \Delta L)$
- Deflection of beams/frames due to axial, shear and flexural deformation,

$$\Delta = \int (x_1 x_0 / EA) dS + \int (v_1 v_0 / GA^*) dS + \int (m_1 m_0 / EI) dS$$
- Deflection of grids due to flexural and torsional deformation, $\Delta = \int (m_1 m_0 / EI) dS + \int (t_1 t_0 / GJ) dS$

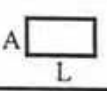
Integration of Product of Functions ($I = \int f_1 f_2 dS$)

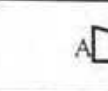
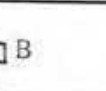
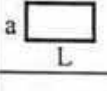
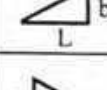
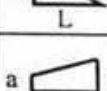
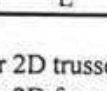
$f_2 \backslash f_1$					
	AaL	$BaL/2$	$AaL/2$	$(A+B)aL/2$	$[A+4C+B]aL/6$
	$AbL/2$	$BbL/3$	$AbL/6$	$[A+2B]bL/6$	$[2C+B]bL/6$
	$AaL/2$	$BaL/6$	$AaL/3$	$[2A+B]aL/6$	$[A+2C]aL/6$
	$A(a+b)L/2$	$B(a+2b)L/6$	$A(2a+b)L/6$	$[A(2a+b)+B(a+2b)]L/6$	$[Aa+Bb+2C(a+b)]L/6$

- $dosi$ for 2D trusses $= m + r - 2j$, for 3D trusses $= m + r - 3j$
- $dosi$ for 2D frames $= 3m + r - h - 3j$, for 3D frames $= 6m + r - 3h - 6j$
- Deflection of beams/frames due to axial, shear and flexural deformation,

$$\Delta_{i,j} = \int (x_i x_j / EA) dS + \int (v_i v_j / GA^*) dS + \int (m_i m_j / EI) dS; M = m_0 + F_1 m_1 + F_2 m_2 + \dots, \text{ etc.}$$
- Compatibility of deflection $\Rightarrow \Delta_{i,0} + F_1 \Delta_{i,1} + F_2 \Delta_{i,2} + \dots + F_n \Delta_{i,n} = \Delta_i$; etc
- Direction cosines of non-coplanar forces, $\cos \alpha = F_x / F$, $\cos \beta = F_y / F$, $\cos \gamma = F_z / F$; where $F = \sqrt{F_x^2 + F_y^2 + F_z^2}$

6. Use the Unit Load Method (considering flexural and shear deformations) to calculate the vertical deflection at B of the beam shown below [Given: $EI = 40 \times 10^3 \text{ k-ft}^2$, $GA^* = 120 \times 10^3 \text{ k}$].

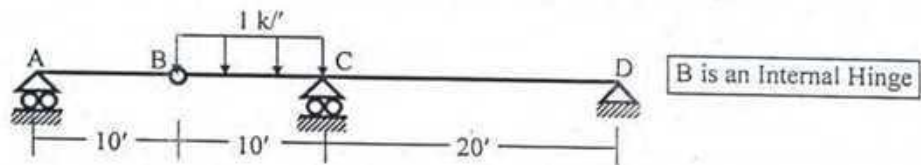

7. Use the Unit Load Method (considering flexural and axial deformations) to calculate the vertical deflection at D of the frame loaded as shown below [Given: $EI = 40 \times 10^3 \text{ k-ft}^2$, $EA = 400 \times 10^3 \text{ k}$].

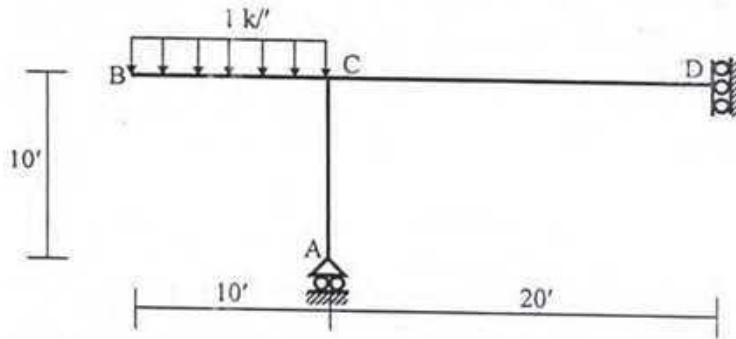

8. Use the Unit Load Method to calculate the horizontal deflection at joint E of the truss loaded as shown below [Given: $EA/L = \text{constant} = 1000 \text{ kip/ft}$].

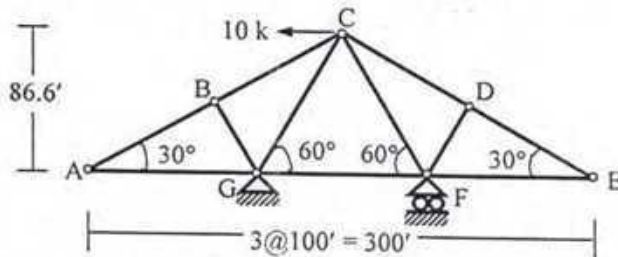

9. Use the Unit Load Method to calculate the vertical deflection at E of the grid shown in the figure below [Given: $EI = 40 \times 10^3 \text{ k-ft}^2$, $GJ = 30 \times 10^3 \text{ k-ft}^2$].

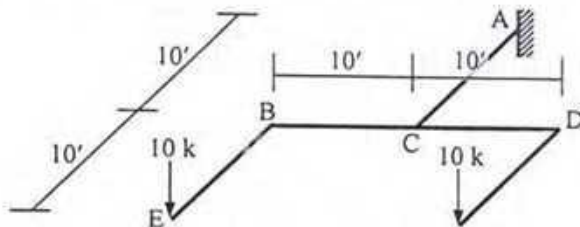

10. Determine the size of the flexibility matrix of the structures shown below. Also convert them to statically determinate structures to be used in 'Case 0' of the Flexibility Method.

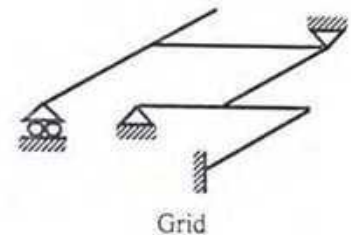
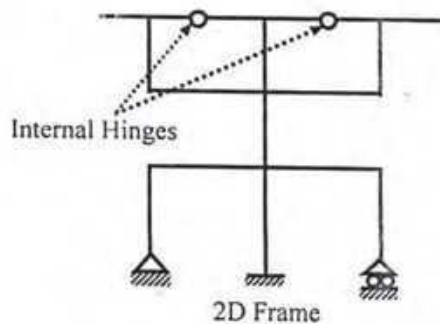
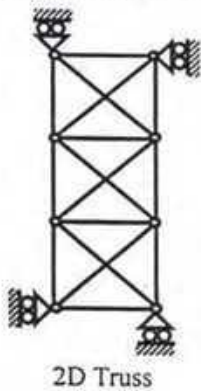

The University of Asia Pacific
Department of Civil Engineering
Final Examination Spring 2007

Course #CE 315
 Full Marks: 150

Course Title: Design of Concrete Structures I
 Time: 3 Hours

Answer SIX Questions including Question No. 1. Question No. 1 is COMPULSORY.

- 1 (a) "In USD, the yield strength of steel is used instead of the ultimate strength of steel" – (25)
 Why?
- (b) "The Φ -factor for shear is less than the Φ -factor for moment" – Why?
- (c) Compare WSD and USD.
- (d) Compare singly reinforced and doubly reinforced concrete beams.
- (e) "Tensile yielding of steel is preferable to compression failure of concrete" - Why?
- (f) Draw the typical compression trajectories and tension trajectories of a simply supported beam subjected to uniformly distributed loading.
- (g) "Maximum shear force is developed at the face of the support but the design shear force is calculated at a distance d (effective depth) from the face of the support" – Why?
- (h) "Plain bars have lower bond strength than deformed bar" – Why?
- (i) "The bond strength of top bars is lower than that of bottom bars" – Why?
- (j) "The temperature and shrinkage reinforcement for slab is placed at the top of the positive steel and at the bottom of the negative steel" – Why?



- 2 (a) Draw the schematic layout of the flexural reinforcement for the following beams (5)
subjected to uniformly distributed load:

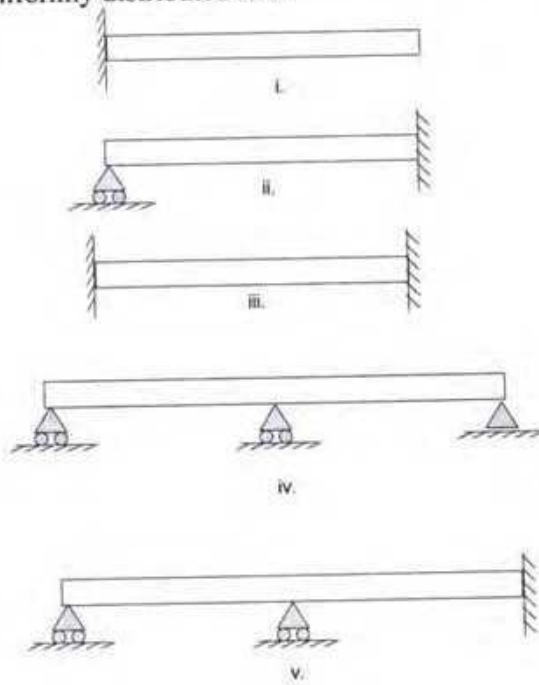

- 2 (b) Design the following simply supported rectangular beam by USD. (20)

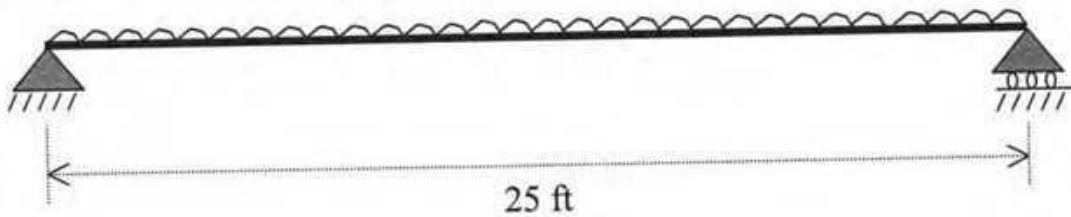

Uniformly distributed live load = 800 lb/ft
 Uniformly distributed dead load = 500 lb/ft
 (self weight of the beam to be considered separately)
 Width of the beam = 12 inch (architectural requirement)
 $f_y = 60,000$ psi, $f_s = 20,000$ psi, $f'_c = 4000$ psi

- 3(a) A simply supported rectangular beam of span 20 feet is subjected to a working load of 5.2 k/ft (including self weight, DL, and LL). Design the shear reinforcement for the beam for three segments. Use WSD. Draw the layout of the stirrups in neat sketches. $f'_c = 3000$ psi, $f_v = 20,000$ psi. Width of the beam = 16 inch and effective depth = 22 inch. (19)
- 3(b) Draw strain and stress variations across the section of a beam due to pure flexure for the following conditions: (6)

- I. Elastic Stress-Strain Behavior, Very low strain level, Tensile stress in concrete is less than the tensile strength of concrete

- II. Tensile stress in concrete is higher than the tensile strength of concrete, elastic stress-strain behavior of concrete, stress in steel is less than the yield strength of steel
- III. Tensile stress of concrete is higher than the tensile strength of concrete, inelastic stress-strain behavior of concrete, stress in steel is equal to the yield strength of steel

4(a) A simply supported beam of span 18 feet is subjected to LL = 2.47 k/ft, DL (including self weight of the beam) = 1.05 k/ft. Due to the architectural reason, the beam size is fixed at 10 inch by 20 inch. Design the beam for moment. Use USD. Given: $f_y = 40,000$ psi, $f'_c = 3000$ psi. (15)

4(b) Derive the following equation for the spacing of shear reinforcement of a beam: (10)

$$S = \frac{\phi A_v f_y d}{V_{ext} - V_{cr}}$$

The symbols carry the usual meanings.

5(a) The cross-section of a reinforced concrete beam is given below. Determine the moment that will cause tensile cracking of concrete. Determine the maximum compressive stress in concrete and stress in steel at this condition. What will happen to the location of the neutral axis if the bending moment is increased further? (15)

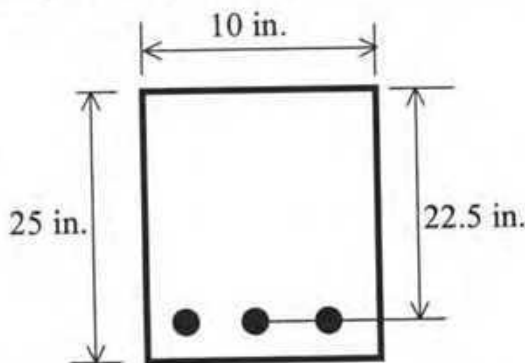

Steel: 3 - #8 Bars
 $f'_c = 3500$ psi
 $f_t = 350$ psi
 $f_y = 40,000$ psi
 $E_s = 29,000,000$ psi

5(b) Define balanced steel ratio. Derive the following equation: (10)

$$\rho_b = \alpha \frac{0.003}{\frac{f_y}{E_s} + 0.003} \frac{f'_c}{f_y}$$

The symbols carry the usual meanings.

6(a) The ultimate design shear of a beam at a critical section (point of inflection) is 42 kips. At this section, 2-#7 bars are provided for the positive moment. Effective depth of the beam is 24 inch. Check the bond stress around the steel bars for the positive moment. Use USD. $f'c = 3000$ psi. (5)

6(b) A slab as shown in the following figure is simply supported on a 10 inch brick wall around the perimeter of the slab. Design the slab by USD. Show the details of the reinforcements. (20)

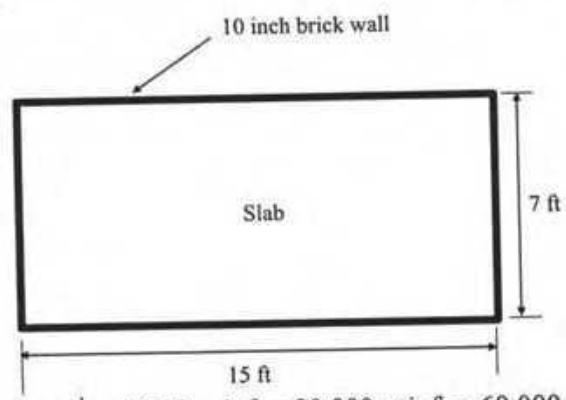

Design parameters: $f'c = 3500$ psi, $f_s = 20,000$ psi, $f_y = 60,000$ psi, LL = 60 psf, Floor Finish = 15 psf, Partition Wall = 25 psf.

7 The layout of the slab and beams of a floor is given below. The slab was made monolithically with the beams. Calculate the steel area necessary for the beam located at the center. Use WSD and USD. Compare the results. Design parameters: $f_s = 20,000$ psi, $f_y = 60,000$ psi, $f'c = 4000$ psi. LL = 2.2 k/ft. (25)

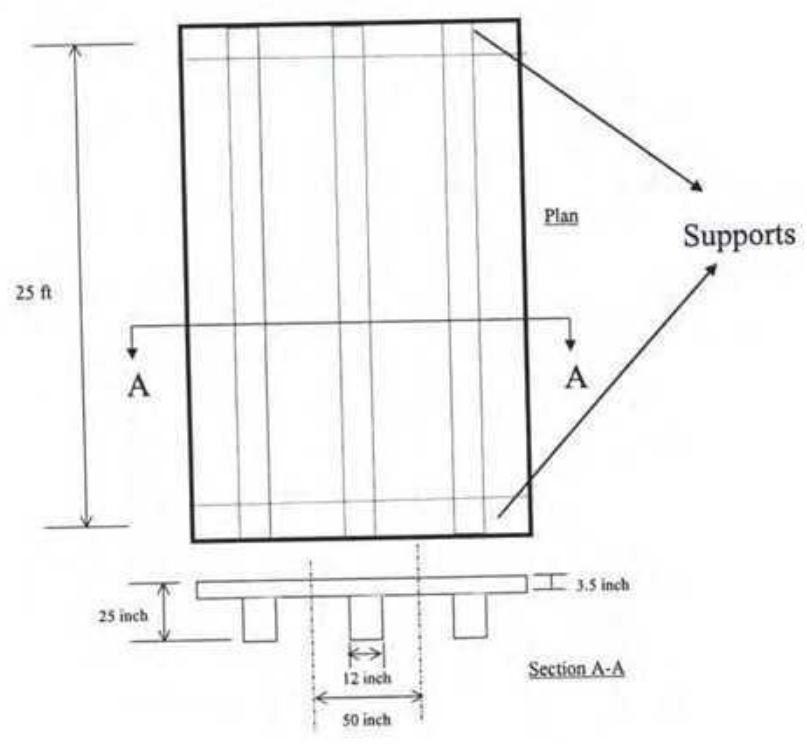

- 3 a. What are the possible effects of discharging hot water to a stream? 4
- b. The BOD₅ of a wastewater is determined to be 150 ml/l at 20°C. What would be the BOD₈ if the test were run at 15°C. Assume K=0.23/day. 5
- c. A city discharges 0.1 m³/s of sewage into a stream whose minimum rate of flow is 1.2 m³/s. The velocity of stream is 1 m/s. The temperature of the wastewater is 20°C, while that of the stream is 15°C. The 20°C BOD₅ of the wastewater is 200 mg/l, while that of the stream is 1.0 mg/l. The wastewater contains no dissolved oxygen, but the stream contains 8gm/l oxygen upstream of the waste discharge. At 20°C K₁ is estimated to be 0.3 per day while K₂ is 0.7 per day. Determine (i) the initial oxygen deficit (ii) the critical oxygen deficit (ii) its time and, (iv) location. 12
- d. Sketch the qualitative DO sag curve and indicate (i) saturated oxygen level (ii) the initial oxygen deficit (iii) the critical oxygen deficit, and (iv) critical time. 4
- 4 a. Give various methods and means of disinfecting of wastewater. 5
- b. Discuss the various important processes that take place in a septic tank. 5
- c. Briefly discuss the mechanism involved in the treatment process of a trickling filter with neat diagram. 5
- d. Briefly describe the direct and indirect reuse of wastewater. 5
- e. Briefly explain reaeration and photosynthesis processes in a river. 5
- 5 a. Write a brief note on, (a) Ion exchange, and (b) Reverse osmosis 6
- b. What are the factors influencing settling velocity of particles in water? Define different types of settling. 8
- c. Write a brief note on chemical characteristics of wastewater. Also mention their sources and environmental significance. 6
- d. Assuming that all particles with settling velocity $V_s > V_c$ will be removed and particles with $V_s < V_c$ will be removed in the proportion $\frac{V_s}{V_c}$, What will be the percentage removal of particles having diameter as follows. 5

Diameter (mm)	0.010	0.015	0.020	0.025	0.030	0.035	0.040
---------------	-------	-------	-------	-------	-------	-------	-------

The sediment tank has an overflow rate of 25 m³/m²d. Take $V=0.01$ cm²/s and density of sediment particles 2 gm/cc.

28

The University of Asia Pacific
Department of Civil Engineering
Final Examination Spring 2007

Course No : CE 333
Full Marks : 150

Course Title: Environmental Engineering II
Time: 3.0 hours

Answer any 6 (SIX) questions. Figures in the right margin indicate full marks.

- 1 a. Terrible mismanagement and irregularities in operation and maintenance of the DHAKA city sewerage system is creating an environmental hazard for city dwellers. As an environmental expert write down some recommendation(s) for the improvement of sewerage system in Dhaka. 6
- b. Define the following terms,
(i) Peak dry weather flow (ii) Peak wet weather flow 6
- c. Write down some typical domestic sewage characteristics. 4
- d. Draw a schematic diagram of a treatment plant showing its various units. 5
- e. Briefly discuss the tasks of an engineer in wastewater management. 4
- 2 a. Determine the discharge and velocity in a 30 cm circular sewer with $n = 0.013$, slope $S = 0.004$ and depth of flow equal to 7.5 cm. (Use enclosed hydraulic elements diagram) 5
- b. Calculate the wastewater quantity (m^3/day) from a small town of 50,000 inhabitants. Total area of the town is 3000 ha. The average water consumption is 140 l/day/capita. A small factory, located in the town, occupied an area of 1500 ha producing 0.30 l/s/ha wastewater. A hotel along with other commercial area occupied 200 ha producing 1.0 l/s/ha wastewater. Assume, peak dry weather factor = 1.7, infiltration factor = 0.5 and ground water constant = 0.4 l/s.ha. 7
- c. A long storm sewer collects water from a catchment area of $0.45 km^2$, where 35% area is covered by roof ($C = 0.9$), 20% area covered by paved roads ($C = 0.8$) and 45% area covered by open land ($C = 0.13$). Determine the diameter of the storm sewer. Assume: Rainfall duration (t) = 15 minutes, 50% flow condition, $S = 0.001 m/m$ and $n = 0.013$. 8
- d. Calculate the wastewater quantity (m^3/day) of a small town of 60,000 inhabitants. The average water consumption is 150 l/day/capita. A small factory locates in the town, has a daily production capacity of 7200 kg. Each kg produced wastewater in average as much as 1.7 inhabitants. There is also a hotel consists of 200 rooms with an average of two beds per room and a restaurant with a capacity of 280 persons in the town. Assume, IE of restaurant seats and beds are 0.2 and 1.5 respectively. 5

- 30
- 6 a. Draw a schematic diagram showing various components of a septic tank. 4
- b. Design a septic tank to serve a household of ten persons who produce 90 lpcd of wastewater. The tank is to be desludged every six years. 12
- c. If the soil is sandy loam with a long-term infiltration rate of about 30 l/m² day. Design a soakage pit for a septic discharging 900 litre effluent everyday. (Assume pit dia=1.25 m) 4
- d. Write a short note on safe disposal techniques of sludge. 5
- 7 a. Briefly discuss the various growth phases of bacteria with neat diagram. 8
- b. Give the name of various important microorganism and their role in biological treatment of wastewater. 6
- c. Differentiate between (i) Aerobic and Anaerobic process
(ii) Nitrification and Denitrification 6
- d. Calculate the effluent BOD of a trickling filter having a depth of 2 m and a recirculated rate of 125 percent of the flow. The influent BOD is 170 mg/l following primary treatment. (Use Velz formula with K=0.49) 5
- 8 a. Define waste stabilization ponds. Also mention its various advantages and disadvantages. 5
- b. Design a waste stabilization pond system to treat wastewater from a low-income settlement with a population of 4,000 at Mirpur, Dhaka. The average wastewater flow is about 100 litres per person per day and the BOD₅ is 400 mg/l. The mean temperature is 23°C. Assume faecal coliform concentration in raw wastewater is 1 x 10⁵ per 100 ml. Assume, Anaerobic, Facultative and Maturation pond depths are 3 m, 1.5 m and 1.25 m respectively, Length : Breadth = 3:1, K_T at 23°C= 6.2 per day, 50% removal efficiency in the facultative pond, 75% surface loading during maturation pond design and consider only one maturation pond. You can assume any other reasonable data, if necessary. What would be the faecal coliform concentration in the treated wastewater. 20

Formulae:

1	$Q = \sum D.d + \sum I.i$	2	$\sum D = P.q_r + A_c q_c + A_i q_i$	
3	$Q = FCIA$ [use $F = 0.278$]	4	$C = \frac{a_1}{A} c_1 + \frac{a_2}{A} c_2 + \dots$	
5	$l = \frac{76.2}{t+10}$ cm/hr	6	$t_c = \frac{FL}{A^{0.1} S^{0.2}}$ (use $F = 58.5$)	
7	$V = \frac{1}{n} R^{\frac{2}{3}} S^{\frac{1}{2}}$	8	$L_t = L_0 e^{-kt}$	
9	$Y_t = L_0 (1 - e^{-kt})$	10	$K_{corrected} = K_{20} (1.047)^{T-20}$	
11	$L_0 = \frac{L_s q_s + L_b q_b}{Q_b + q_s}$	12	$DO_0 = \frac{DO_s q_s + DO_b q_b}{Q_b + q_s}$	
13	$DO_{sat} = 14.62 - 0.4042 T + 0.00842 T^2 - 0.00009 T^3$			
14	$D_{crit} = \frac{K_1}{K_2} L_0 e^{-K_1 t_c}$	15	$X_{crit} = v t_{crit}$	
16	$t_{crit} = \frac{1}{K_2 - K_1} \ln \left[\frac{K_2}{K_1} \left(1 - \frac{D_0 (K_2 - K_1)}{K_1 L_0} \right) \right]$	17	$DO_{crit} = DO_{sat} - D_{crit}$	
18	$V_s = \frac{g}{18\nu} \frac{\rho_s - \rho}{\rho} d^2$	19	$C_s = \left(\frac{C_i + r C_e}{1+r} \right) e^{-kD}$	
20	$V = V_h + V_d + 1.4 V_{sl}$ $V_{sc} = 0.4 V_{sl}$ $t_h = 1.5 - 0.3 \log (Pq)$ $V_h = 10^{-3} Pq t_h$	$t_d = 30 (1.035)^{35-T}$ $V_d = 0.5 \times 10^{-3} P t_d$ $V_{sl} = C \times P \times N$ $d_{sc} = 0.82 - 0.26A$	21	$\lambda_s = L_i Q / V_s$ $\lambda_t = 10 L_i Q / A_f$ $K_r = 2.6 (1.19)^{(T-20)}$ $\theta = V/Q$ $N_s = N_i / (1 + K_r \theta_s) (1 + K_r \theta_t) (1 + K_r \theta_m)$ $\theta_s = \left[N_i / N_s (1 + K_r \theta_s) (1 + K_r \theta_t) \right]^{-1} / K_r$

Table-1: Design values of λ_v and BOD removal rate at various temperatures

Temperature(°c)	Volumetric loading rate (g BOD/m ³ day)	BOD removal (%)
20	300	60
21	300	62
22	300	64
23	300	66
24	300	68
>25	300	70

Table-2: Design values for surface BOD loading rates for facultative ponds at various temperatures

Temperature(°c)	Surface loading rate (kgBOD/ha.day)	Temperature(°c)	Surface loading rate (kgBOD/ha.day)
16	183	21	272
17	199	22	292
18	217	23	311
19	235	24	331
20	253	25	350

Figure-1: Hydraulic elements diagram for circular sewer

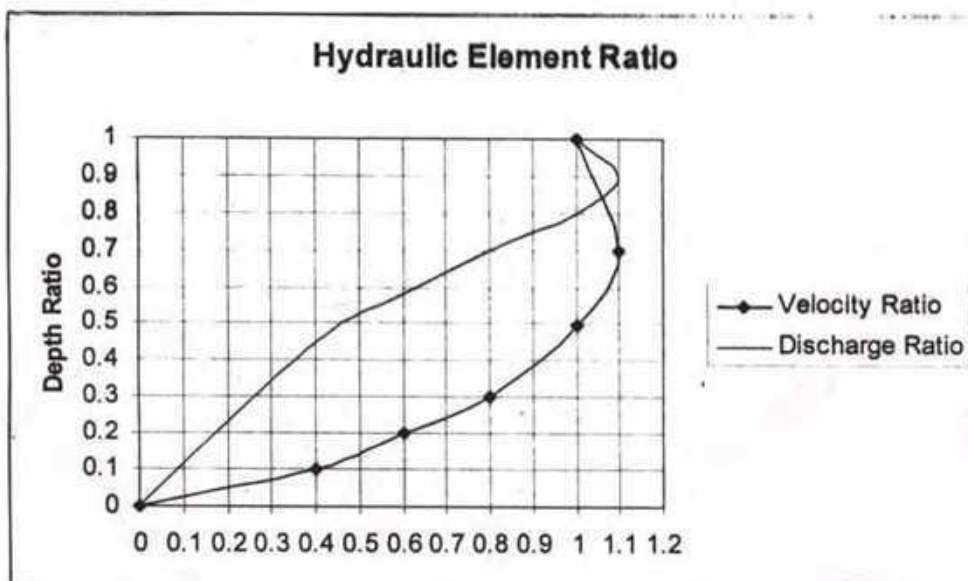

9. In the truss shown below, ignore the zero-force members and formulate the stiffness matrix, load vector and write down the boundary conditions [Given: $EA/L = \text{constant} = 1000 \text{ kip/ft}$].

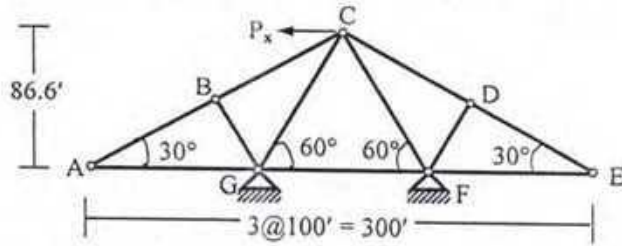

10. For the truss described in Question 9, the force in member CF is 10 k (tension). Calculate the applied load P_x , forces in the other members of the truss and the horizontal and vertical deflections of joint C.

11. In the three-dimensional truss OABC shown below (with nodal coordinates), ignore the zero-force members and formulate the stiffness matrix, load vector and write down the boundary conditions [Given: $EA/L = \text{constant} = 1000 \text{ kip/ft}$].

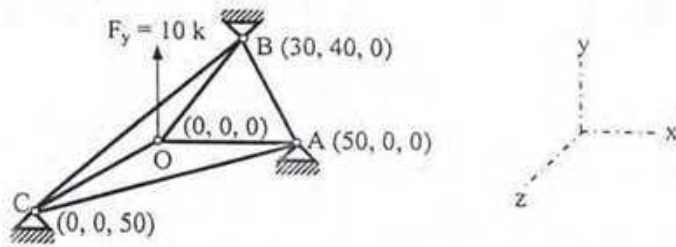

12. Use the Stiffness Method to calculate the rotations at joint D of the grid shown in the figure below [Given: $EI = 40 \times 10^3 \text{ k-ft}^2$, $GJ = 30 \times 10^3 \text{ k-ft}^2$].

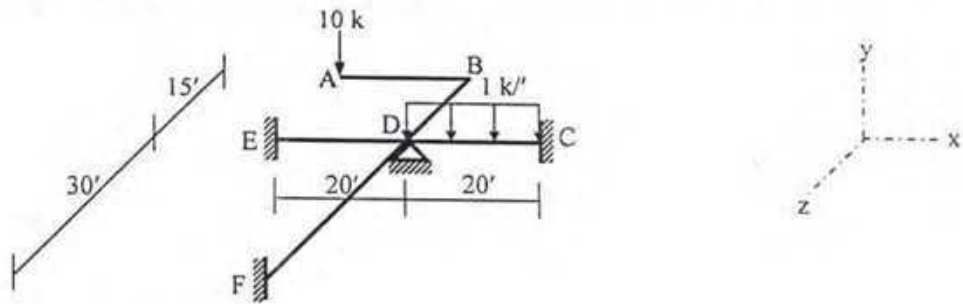

13. Briefly explain why
- (i) results from the Moment Distribution Method are approximate,
 - (ii) results using assumed shape functions are usually not exact,
 - (iii) three-dimensional frame analysis requires sectional and material properties like J , I_y , I_z and G ,
 - (iv) structural deflections are magnified due to geometric nonlinearity caused by compressive forces.
14. Determine the size of the stiffness matrix (considering boundary conditions also) of the frames shown below. Also determine the size of the stiffness matrix if axial deformations are neglected.

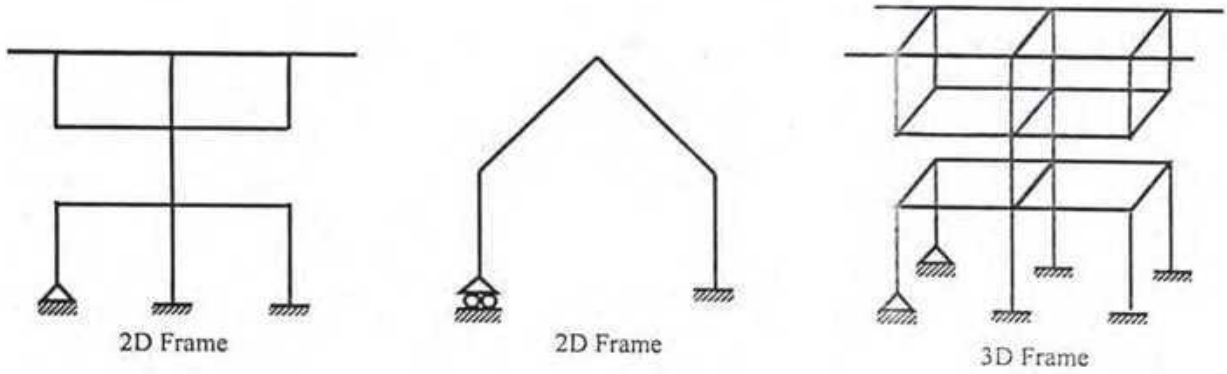

The University of Asia Pacific
Department of Civil Engineering
Final Examination Spring 2007

Course #: CE 411
 Full Marks: 100 (= 10 × 10)

Course Title: Structural Analysis & Design III
 Time: 3 hours

[Answer any 10 (ten) of the following 14 questions]

1. Use the Stiffness Method neglecting axial deformations to calculate the deflection at joint A and rotation at joint C of the beam shown below, if in addition to the applied load, support B settles 0.10' downward [Given: $P = 0$, $EI_{AB} = 40 \times 10^3 \text{ k-ft}^2$, $EI_{BCD} = EI_{AB}/2$].

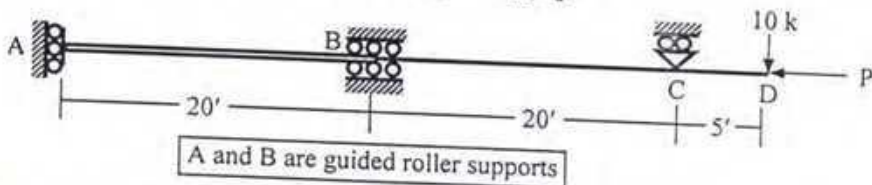

2. Use the Moment Distribution method to draw the bending moment diagram of the beam ABCD described in Question 1 (*Extend the structure using symmetry*).
3. For the beam ABCD described in Question 1 (excluding the applied load and support settlement),
 (i) draw the qualitative influence lines of R_B , R_C , M_A , $M_{B(\text{left})}$ and $M_{B(\text{right})}$.
 (ii) show the placement of a uniformly distributed dead load of 2 k/ft and a moving uniformly distributed live load of 0.5 k/ft in order to obtain the maximum positive values of R_B , R_C , M_A and maximum negative values of $M_{B(\text{left})}$ and $M_{B(\text{right})}$.
4. Calculate the value of the force P to cause buckling of the beam ABCD shown in Question 1.
5. Use the Stiffness Method to calculate the horizontal deflections at joint B and C of the axially loaded beam ABCD shown in Question 1 [Given: $P = 100 \text{ kips}$, $EA_{AB} = 400 \times 10^3 \text{ k}$, $EA_{BCD} = EA_{AB}/2$].
6. For the axially loaded beam ABCD shown in Question 1,
 (i) show that $\phi(x) = x/40$ [$x_A = 0$ and $x_C = 40'$] is a valid shape function,
 (ii) use this shape function to calculate the horizontal deflection at joint C of the bar
 [Given: $P = 100 \text{ kips}$, $EA_{AB} = 400 \times 10^3 \text{ k}$, $EA_{BCD} = EA_{AB}/2$].
7. Use the Stiffness Method (with flexural deformations only) to calculate the rotations at joint B and joint C of the frame loaded as shown below [Given: $EI = \text{constant} = 40 \times 10^3 \text{ k-ft}^2$].

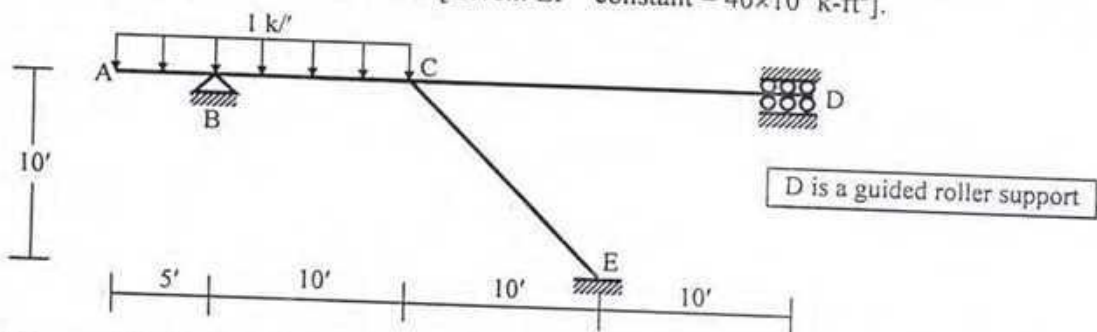

8. Use the Moment Distribution Method to draw the bending moment diagram of the frame described in Question 7.

List of Useful Formulae for CE 411

- * For member with fixed far end, Rotational stiffness = $4EI/L$, Carry over factor = 0.5
- * For member with hinged/roller/discontinuous far end, Rotational stiffness = $3EI/L$, Carry over factor = 0
- * The moment distribution factors of members OA, OB,..... are $[K_{OA}/K_O]$, $[K_{OB}/K_O]$,.....respectively.

Fixed End Reactions for One-dimensional Prismatic Members under Typical Loadings

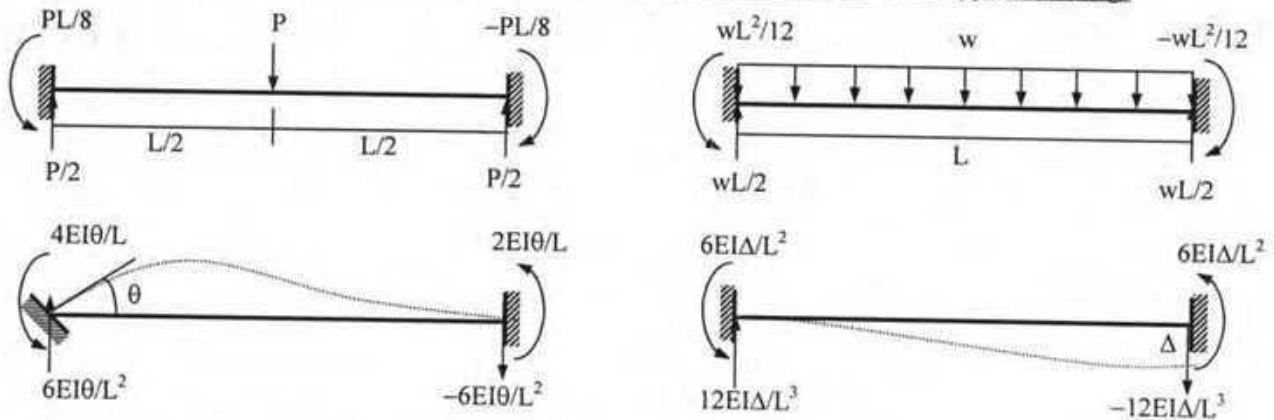

- * The stiffness matrix \mathbf{K}_m^G of a 2D truss member in the global axis system is given by

$$\mathbf{K}_m^G = S_x \begin{pmatrix} C^2 & CS & -C^2 & -CS \\ CS & S^2 & -CS & -S^2 \\ -C^2 & -CS & C^2 & CS \\ -CS & -S^2 & CS & S^2 \end{pmatrix} \quad \text{and Truss member force, } P_{AB} = S_x [(u_B - u_A) C + (v_B - v_A) S]$$

[where $C = \cos \theta$, $S = \sin \theta$]

- * Torsional stiffness = GJ/L

- * For axially loaded member, $k^* u_1 = f^*$; where $k^* = \int EA [\phi'(x)]^2 dx$, $f^* = \int p(x) \phi(x) dx$
- * For transversely loaded member, $k^* u_2 = f^*$; where $k^* = \int EI [\psi''(x)]^2 dx$, $f^* = \int q(x) \psi(x) dx$

- * Assumed shape $\psi(x) \Rightarrow$ Geometric Stiffness, $g^* = \int P [\psi'(x)]^2 dx$; and $k_{Total}^* = k^* + g^*$

- * Ignoring axial deformations, the matrices \mathbf{K}_m^L and \mathbf{G}_m^L of a frame member in the local axis system are

$$\mathbf{K}_m^L = \begin{pmatrix} S_1 & S_2 & -S_1 & S_2 \\ S_2 & S_3 & -S_2 & S_4 \\ -S_1 & -S_2 & S_1 & -S_2 \\ S_2 & S_4 & -S_2 & S_3 \end{pmatrix} \quad \mathbf{G}_m^L = (P/30L) \begin{pmatrix} 36 & 3L & -36 & 3L \\ 3L & 4L^2 & -3L & -L^2 \\ -36 & -3L & 36 & -3L \\ 3L & -L^2 & -3L & 4L^2 \end{pmatrix}$$

where $S_1 = 12EI/L^3$, $S_2 = 6EI/L^2$, $S_3 = 4EI/L$, $S_4 = 2EI/L$, using $K_{mij} = \int EI \psi_i'' \psi_j'' dx$, $G_{mij} = P \int \psi_i' \psi_j' dx$
 $\psi_1(x) = 1 - 3(x/L)^2 + 2(x/L)^3$, $\psi_2(x) = L \{x/L - 2(x/L)^2 + (x/L)^3\}$, $\psi_3(x) = 3(x/L)^2 - 2(x/L)^3$, $\psi_4(x) = L \{-(x/L)^2 + (x/L)^3\}$

- * $\mathbf{K}_{Total} = \mathbf{K} + \mathbf{G}$, buckling occurs when $|\mathbf{K}_{Total}| = 0$

- * The stiffness matrix of a 3D truss member in the global axes system [using $C_x = \cos \alpha$, $C_y = \cos \beta$, $C_z = \cos \gamma$] is

$$\mathbf{K}_m^G = S_x \begin{pmatrix} C_x^2 & C_x C_y & C_x C_z & -C_x^2 & -C_x C_y & -C_x C_z \\ C_y C_x & C_y^2 & C_y C_z & -C_y C_x & -C_y^2 & -C_y C_z \\ C_z C_x & C_z C_y & C_z^2 & -C_z C_x & -C_z C_y & -C_z^2 \\ -C_x^2 & -C_x C_y & -C_x C_z & C_x^2 & C_x C_y & C_x C_z \\ -C_y C_x & -C_y^2 & -C_y C_z & C_y C_x & C_y^2 & C_y C_z \\ -C_z C_x & -C_z C_y & -C_z^2 & C_z C_x & C_z C_y & C_z^2 \end{pmatrix}$$

- * Member force $P_{AB} = S_x [(u_B - u_A) C_x + (v_B - v_A) C_y + (w_B - w_A) C_z]$

Q4 (a): A simply supported beam of span 22' long having an I section as shown in Fig.4 (a) is subjected to transverse load acting through the shear center. Determine the critical intensity of load w in lb/ft for lateral torsional buckling of the beam. [14]

Given: Effective length co-efficient=1, Poisson's ratio=0.25, $C_b=1.13$, $E=30,000$ ksi
 Critical moment for lateral torsional buckling is given by

$$M_{x_{cr}}^2 = C_b^2 \left[\frac{\pi^2}{(KL)^2} EI_y GJ + \frac{\pi^4}{(KL)^4} EI_y EC_w \right]$$

here, $C_w = I_y d^2 / 4$ and $J = \sum (bt^3 / 3)$

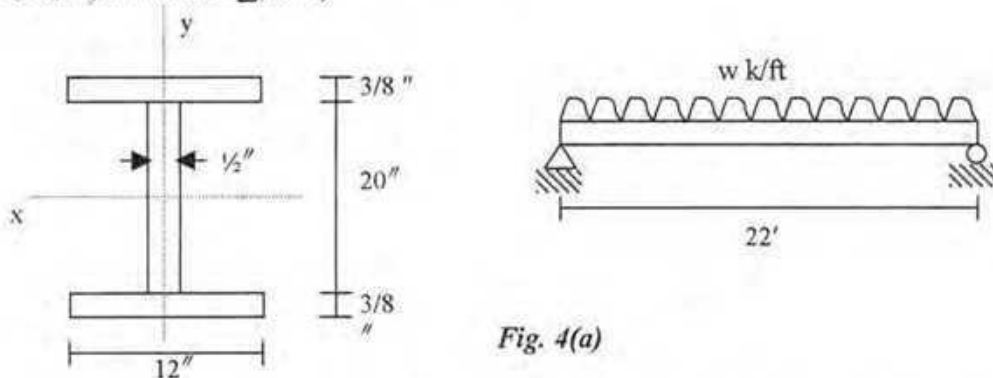

Fig. 4(a)

Q4 (b): The section shown in Fig.4 (b) is selected to be used as beam. Find the value of Plastic moment, (M_p) and shape factor of this section about major axis. Use $F_y = 36$ ksi [6]

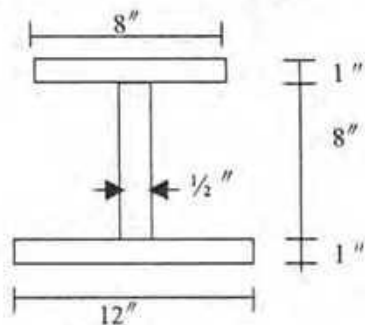

Fig. 4(b)

Q5: Design by AISC/ASD method, an A36 steel double angle (unequal leg with long leg back to back) tension member shown in Fig.5. The member is 22' long and will carry 80 kips dead load and 130 kips live load. Connection to a gusset plate is provided by fillet welds deposited with E70XX electrodes at the three edges (one transverse and two longitudinal) [20]

[Use Appendices for required table].

Allowable stress on gross area = $0.6F_y$, and on effective net area = $0.5F_u$

Allowable shear stress on fillet welds = $0.3 \times$ nominal tensile strength of weld metal

Allowable shear stress on steel = $0.4F_y$

Allowable load on block shear = $0.3F_u A_{nv} + 0.5F_u A_{nt}$

Assume reduction factor $U = 0.85$, thickness of gusset plate = $3/8$ " [perform check for gusset plate thickness]

Width of gusset plate at section a-a is 11 in.

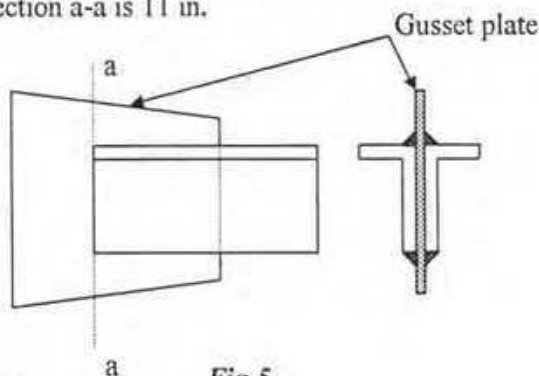

Fig.5

Q6 (a): Using column load table, select the lightest W14 shape of A36 steel to support a dead load of 200 kips and a live load of 300 kips. The column is 32 ft long. Assume that it is pin-supported at the top and bottom in both direction and that an additional support is provided at mid-length to prevent buckling about the y axis so that $K_x L_x = 32$ ft and $K_y L_y = 16$ ft
[relevant column load table is provided with the question paper] [16]

Q6 (b): The following loads have been estimated for a column design: dead load of 80 kips, floor live load of 60 kips, roof live load of 10 kips, and wind load of 55 kips. What is the factored load for designing the member? [4]

Q7: Select the lightest W section to carry a uniformly distributed live load 2.0 k/ft and dead load (excluding the wt of the beam) of 0.50 k/ft on a 36 ft span simply supported beam as in Fig.7. Lateral supports are provided at 10 ft from each support. Use steel with $F_y = 65$ ksi and AISC/ASD method of design. Live load deflection is to be limited to 1/300 of the span. Check the selected section against local buckling
[Relevant section properties and formulas are provided with the question paper]. [20]

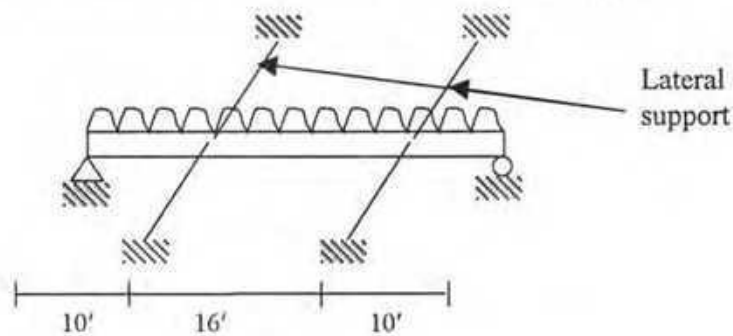

Fig.7

The University of Asia Pacific
Department of Civil Engineering
Final Examination Spring 2007

Course #: CE 417
Full Marks: 100

Course Title: Structural Analysis & Design VI
Time : 2 hrs

There are seven questions in this paper. Answer any five.

Q1 (a): Determine the effective lengths for column CF, FI, IK, BE of the frame shown in Fig. 1. The moments of inertia for the columns and beams are shown in the figure [Use nomograph provided with the question paper]. [14]

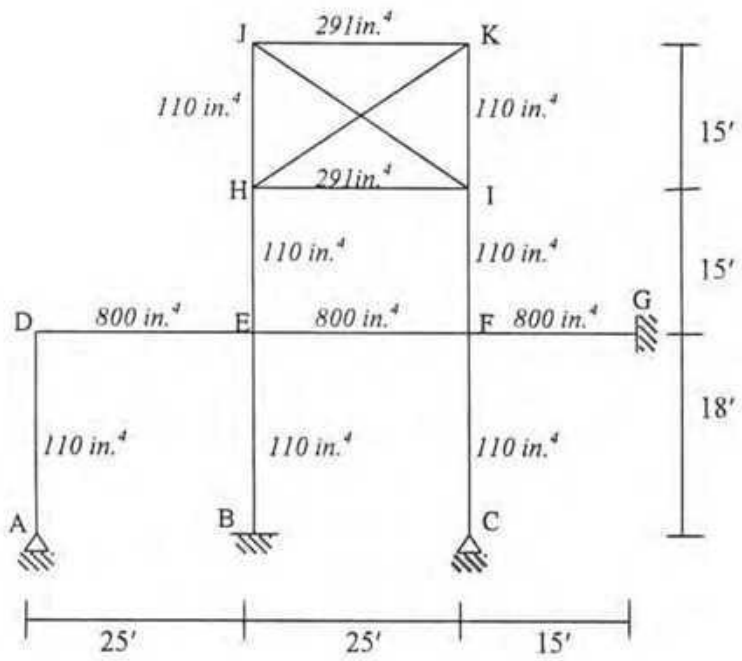

Fig. 1

Q1 (b): Define: (i) Lateral torsional buckling (ii) Compact section (iii) Effective net area [6]

Q2 (a): For a rectangular cross section of a steel member shown in Fig.2 (a), strain and stress diagrams at yield are given. Yield moment capacity for the section is given by $M_y = F_y S$, where, section modulus, $S = bd^2/6$. If the section is strained 2 times and 5 times its yield strain ϵ_y , what will be its bending moment in terms of M_y ? [4]

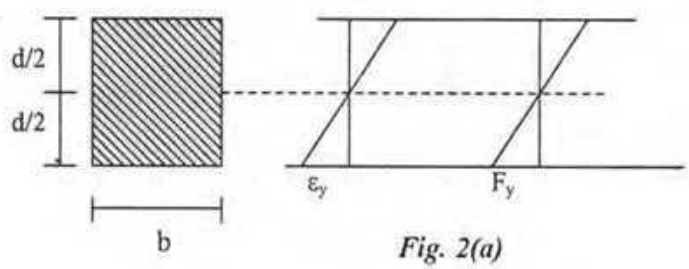
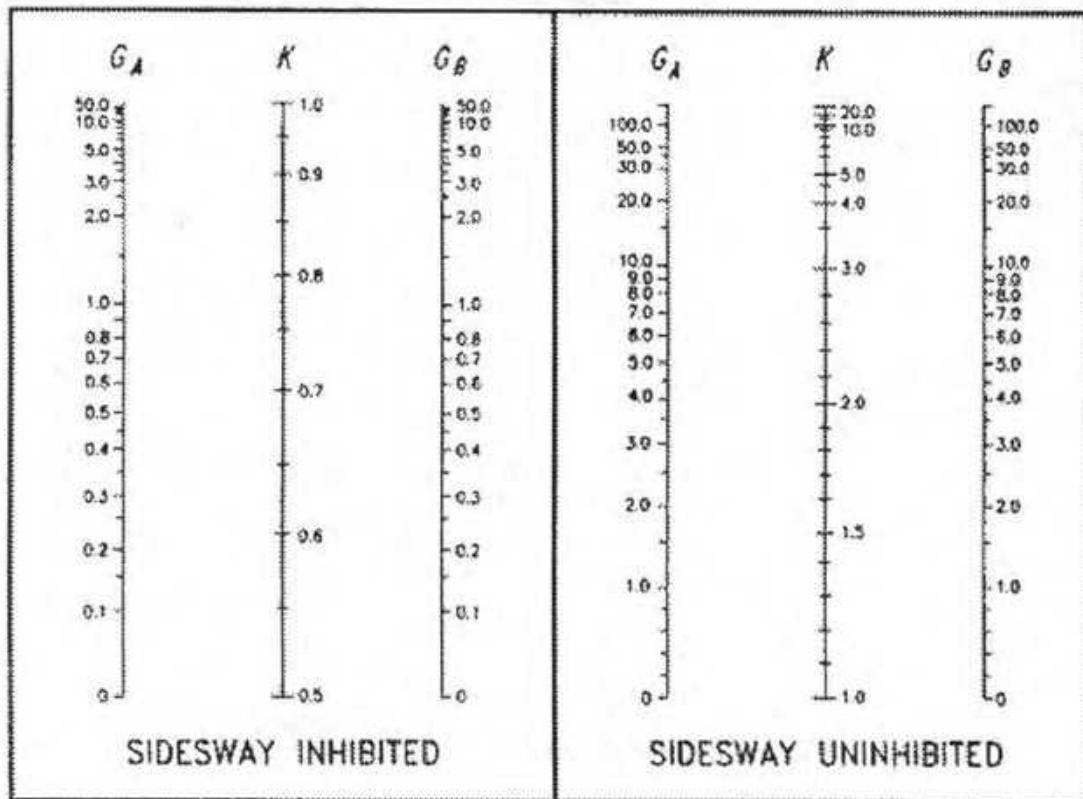

Fig. 2(a)



Appendix-1



Nomograph for effective length of columns in continuous frames.

Correction factors for beam stiffness		
Condition	Side sway	No side sway
Far end of beam hinged	1/2	3/2
Far end of beam fixed	2/3	2

Fillet Weld sizes	
Size of fillet Weld, in.	Maximum thickness of part, in.
1/8	To 1/4
3/16	Over 1/4 to 1/2
1/4	Over 1/2 to 3/4
5/16	Over 3/4

Appendix-2

Formulas (the symbols carry their usual meaning)

$$L_c = \begin{cases} \frac{76b_f}{\sqrt{F_y}} \\ \frac{20000}{F_y} \frac{d}{A_f} \end{cases}$$

$$F_b = 0.6F_y \text{ if } L_c < L < L_u = \begin{cases} \frac{20000C_b}{\frac{d}{A_f} F_y} \\ r_T \sqrt{\frac{102000C_b}{F_y}} \end{cases}$$

$$F_b = \begin{cases} \frac{12000C_b}{L \frac{d}{A_f}} \\ \left[\frac{2}{3} - \frac{F_y \left(\frac{L}{r_T}\right)^2}{1530 \times 10^3 C_b} \right] F_y \end{cases}$$

But not greater than $0.6F_y$; if $\frac{L}{r_T} \leq \sqrt{\frac{510000C_b}{F_y}}$

$$F_b = \begin{cases} \frac{170000C_b}{\left(\frac{L}{r_t}\right)^2} \\ \frac{12000C_b}{L \frac{d}{A_f}} \end{cases}$$

But not greater than $0.6F_y$; if $\frac{L}{r_T} > \sqrt{\frac{510000C_b}{F_y}}$

$C_b = 1.75 + 1.05(M_1/M_2) + 0.3(M_1/M_2)^2$ Where, M_1 is the smaller of the two end moments M_1 and M_2 , M_1/M_2 is positive for reverse-curvature bending.

$$F_a = \frac{F_y \left[1 - \frac{1}{2} \left(\frac{KL/r}{C_c} \right)^2 \right]}{\frac{5}{3} + \frac{3}{8} \left(\frac{KL/r}{C_c} \right) - \frac{1}{8} \left(\frac{KL/r}{C_c} \right)^3}$$

if $\frac{KL}{r} \leq C_c$

$$F_a = \frac{12\pi^2 E}{23 \left(\frac{KL}{r} \right)^2}$$

if $\frac{KL}{r} \geq C_c$

Where, $C_c = \sqrt{\frac{2\pi^2 E}{F_y}}$

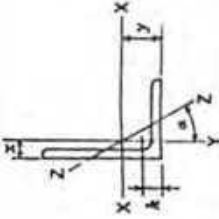

ANGLES Equal legs and unequal legs Properties for designing

Size and Thickness in.	k in.	Weight per Foot lb.	AXIS X-X			AXIS Y-Y			AXIS Z-Z			
			I in. ⁴	S in. ³	r in.	I in. ⁴	S in. ³	r in.	I in. ⁴	S in. ³	r in.	Tan α
L 5 x 3 1/2 x 3/4	1 1/4	19.8	5.81	4.28	1.55	1.75	5.55	2.22	0.977	0.996	0.748	0.464
1/2	1 1/4	16.8	4.92	3.65	1.56	1.70	4.83	1.90	0.991	0.951	0.751	0.472
3/8	1	13.6	4.00	2.99	1.58	1.66	4.05	1.56	1.01	0.906	0.755	0.479
5/16	3/4	12.0	3.53	2.64	1.59	1.63	3.63	1.39	1.01	0.883	0.758	0.482
3/8	3/4	10.4	3.05	2.29	1.60	1.61	3.18	1.21	1.02	0.881	0.762	0.486
5/16	3/4	8.7	2.56	1.94	1.61	1.59	2.72	1.02	1.03	0.838	0.766	0.489
3/8	3/4	7.0	2.06	1.57	1.57	1.56	2.23	0.830	1.04	0.814	0.770	0.492
L 5 x 3 x 1/2	1 1/4	15.7	4.61	3.55	1.57	1.80	3.06	1.39	0.815	0.796	0.644	0.349
1/2	1	12.8	3.75	2.91	1.59	1.75	2.58	1.15	0.829	0.750	0.648	0.357
3/4	1 1/4	11.3	3.31	2.58	1.60	1.73	2.32	1.02	0.837	0.727	0.651	0.361
5/8	3/4	9.8	2.86	2.24	1.61	1.70	2.04	0.888	0.845	0.704	0.654	0.364
3/8	3/4	8.2	2.40	1.89	1.61	1.68	1.75	0.753	0.853	0.681	0.658	0.368
5/16	3/4	6.6	1.94	1.53	1.62	1.66	1.44	0.614	0.861	0.657	0.663	0.371
L 4 x 4 x 3/4	1 1/4	18.5	5.44	4.28	1.19	1.27	7.67	2.81	1.19	1.27	0.778	1.000
3/4	1	15.7	4.61	3.66	1.20	1.23	6.66	2.40	1.20	1.23	0.779	1.000
5/8	3/4	12.8	3.75	2.91	1.22	1.18	5.56	1.97	1.22	1.18	0.782	1.000
3/8	3/4	11.3	3.31	2.58	1.23	1.16	4.97	1.75	1.23	1.16	0.785	1.000
5/16	3/4	9.8	2.86	2.24	1.23	1.14	4.36	1.52	1.23	1.14	0.788	1.000
3/8	3/4	8.2	2.40	1.89	1.29	1.24	3.71	1.29	1.24	1.12	0.791	1.000
5/16	3/4	6.6	1.94	1.53	1.25	1.09	3.04	1.05	1.25	1.09	0.795	1.000
L 4 x 3 1/2 x 5/8	1 1/4	14.7	4.30	3.37	1.22	1.29	4.52	1.84	1.03	1.04	0.719	0.745
5/8	1 1/4	11.9	3.50	2.91	1.23	1.25	3.79	1.52	1.04	1.00	0.722	0.750
3/4	1 1/4	10.6	3.09	2.58	1.24	1.23	3.40	1.35	1.05	0.978	0.724	0.753
5/8	1 1/4	9.1	2.67	2.18	1.25	1.21	2.95	1.17	1.06	0.955	0.727	0.755
3/8	3/4	7.7	2.25	1.89	1.26	1.18	2.55	0.994	1.07	0.932	0.730	0.757
5/16	3/4	6.2	1.81	1.53	1.27	1.16	2.09	0.808	1.07	0.909	0.734	0.759

Angles in shaded rows may not be readily available. Availability is subject to rolling accumulation and geographical location, and should be checked with material suppliers.

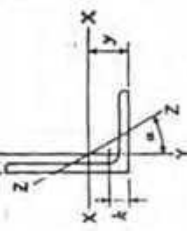

ANGLES Equal legs and unequal legs Properties for designing

Size and Thickness in.	k in.	Weight per Foot lb.	AXIS X-X			AXIS Y-Y			AXIS Z-Z			
			I in. ⁴	S in. ³	r in.	I in. ⁴	S in. ³	r in.	I in. ⁴	S in. ³	r in.	Tan α
L 4 x 3 x 3/4	1 1/4	13.6	3.98	2.90	1.23	1.37	2.87	1.35	0.849	0.871	0.637	0.524
3/4	1 1/4	11.1	3.25	2.50	1.25	1.30	2.42	1.12	0.864	0.827	0.639	0.543
5/8	1 1/4	9.8	2.87	2.18	1.25	1.30	2.18	0.992	0.871	0.804	0.641	0.567
3/8	3/4	8.5	2.48	1.86	1.26	1.28	1.92	0.866	0.879	0.782	0.644	0.551
5/16	3/4	7.2	2.09	1.58	1.27	1.26	1.65	0.734	0.887	0.759	0.647	0.554
3/8	3/4	5.8	1.69	1.27	1.28	1.24	1.36	0.599	0.896	0.735	0.651	0.558
L 3 1/2 x 3 1/2 x 1/2	3/4	11.1	3.25	2.50	1.06	1.06	3.64	1.49	1.06	1.06	0.683	1.000
5/8	3/4	8.5	2.87	2.18	1.07	1.04	3.26	1.32	1.07	1.04	0.684	1.000
3/4	3/4	8.2	2.48	1.86	1.07	1.01	2.87	1.15	1.07	1.01	0.687	1.000
5/16	3/4	7.2	2.09	1.58	1.08	0.990	2.45	0.976	1.08	0.990	0.690	1.000
3/8	3/4	5.8	1.69	1.27	1.09	0.968	2.01	0.794	1.09	0.968	0.694	1.000
L 3 1/2 x 3 x 1/2	3/4	10.2	3.00	2.45	1.07	1.13	3.33	1.10	0.881	0.875	0.621	0.714
5/8	3/4	9.1	2.65	2.10	1.08	1.10	2.99	0.975	0.889	0.853	0.622	0.718
3/8	3/4	7.9	2.30	1.72	1.09	1.08	2.72	0.851	0.897	0.830	0.625	0.721
5/16	3/4	6.6	1.93	1.43	1.10	1.06	2.45	0.722	0.905	0.808	0.627	0.724
3/8	3/4	5.4	1.56	1.19	1.11	1.04	2.01	0.589	0.914	0.785	0.631	0.727
L 3 1/2 x 2 1/2 x 5/8	3/4	9.4	2.75	2.24	1.09	1.20	3.36	1.06	0.760	0.704	0.705	0.534
5/8	3/4	8.3	2.43	2.01	1.09	1.18	3.03	0.954	0.711	0.682	0.535	0.491
3/8	3/4	7.2	2.11	1.72	1.09	1.16	2.72	0.833	0.719	0.660	0.537	0.496
5/16	3/4	6.1	1.78	1.51	1.10	1.14	2.45	0.707	0.727	0.637	0.540	0.501
3/8	3/4	4.9	1.44	1.24	1.11	1.11	2.11	0.577	0.735	0.614	0.544	0.506
L 3 x 3 x 1/2	3/4	9.4	2.75	2.22	1.07	0.898	3.32	1.07	0.898	0.932	0.584	1.000
5/8	3/4	8.3	2.43	1.99	0.954	0.905	2.99	0.954	0.905	0.910	0.585	1.000
3/8	3/4	7.2	2.11	1.76	0.933	0.913	2.76	0.833	0.913	0.888	0.587	1.000
5/16	3/4	6.1	1.78	1.51	0.933	0.913	2.45	0.707	0.922	0.865	0.589	1.000
3/8	3/4	4.9	1.44	1.24	0.933	0.913	2.11	0.577	0.930	0.842	0.592	1.000
5/16	3/4	3.71	1.09	0.962	0.933	0.913	1.81	0.441	0.939	0.820	0.596	1.000

Angles in shaded rows may not be readily available. Availability is subject to rolling accumulation and geographical location, and should be checked with material suppliers.

ANGLES

Equal legs and unequal legs
Properties for designing

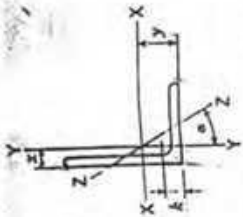

Size and Thickness in.	k in.	Weight per Foot Lb.	AXIS X-X			AXIS Y-Y			AXIS Z-Z				
			I in. ⁴	S in. ³	r in.	I in. ⁴	S in. ³	r in.	I in. ⁴	S in. ³	r in.		
L 3 x 2 1/2 x 1/2	7/16	8.5	2.08	1.04	0.913	1.00	1.30	0.744	0.722	0.750	0.520	0.667	
	1/8	7.6	1.88	0.928	0.920	0.978	1.18	0.664	0.729	0.728	0.521	0.672	
	3/4	6.6	1.92	0.810	0.928	0.956	1.04	0.581	0.736	0.706	0.522	0.676	
	1/16	5.6	1.62	0.688	0.937	0.933	0.898	0.494	0.744	0.683	0.525	0.680	
	1/4	4.5	1.31	0.561	0.945	0.911	0.743	0.404	0.753	0.661	0.528	0.684	
	3/16	3.39	0.996	0.430	0.954	0.888	0.577	0.310	0.761	0.638	0.533	0.688	
L 3 x 2 x 1/2	7/16	7.7	2.25	1.00	0.924	1.08	0.672	0.474	0.546	0.583	0.428	0.414	
	1/8	6.8	2.00	0.894	0.932	1.06	0.609	0.424	0.553	0.561	0.429	0.421	
	3/4	5.9	1.73	0.781	0.940	1.04	0.543	0.371	0.559	0.539	0.430	0.428	
	1/16	5.0	1.46	0.664	0.948	1.02	0.470	0.317	0.567	0.516	0.432	0.435	
	1/4	4.1	1.19	0.542	0.957	0.993	0.392	0.260	0.574	0.493	0.435	0.440	
	3/16	3.07	0.902	0.415	0.966	0.970	0.307	0.200	0.583	0.470	0.439	0.446	
L 2 1/2 x 2 1/2 x 1/2	7/16	7.7	2.25	1.23	0.724	0.739	0.806	1.23	0.724	0.739	0.806	0.487	1.000
	1/8	5.9	1.73	0.984	0.566	0.753	0.762	0.984	0.566	0.753	0.762	0.487	1.000
	3/4	5.0	1.46	0.849	0.482	0.761	0.740	0.849	0.482	0.761	0.740	0.489	1.000
	1/16	4.1	1.19	0.703	0.394	0.769	0.717	0.703	0.394	0.769	0.717	0.491	1.000
	1/4	3.07	0.902	0.547	0.303	0.778	0.694	0.547	0.303	0.778	0.694	0.495	1.000
	3/16	5.3	1.55	0.912	0.547	0.768	0.831	0.514	0.363	0.577	0.581	0.420	0.614
L 2 1/2 x 2 x 1/2	7/16	4.5	1.31	0.788	0.466	0.776	0.809	0.446	0.310	0.584	0.559	0.422	0.620
	1/8	3.62	1.06	0.654	0.381	0.784	0.787	0.372	0.254	0.592	0.537	0.424	0.626
	3/4	2.75	0.809	0.509	0.293	0.793	0.764	0.291	0.196	0.600	0.514	0.427	0.631
	1/16	4.7	1.36	0.479	0.351	0.594	0.636	0.479	0.351	0.594	0.636	0.389	1.000
	1/4	3.92	1.15	0.416	0.300	0.601	0.614	0.416	0.300	0.601	0.614	0.390	1.000
	3/16	3.19	0.938	0.348	0.247	0.609	0.592	0.348	0.247	0.609	0.592	0.391	1.000
L 2 x 2 x 1/2	7/16	2.44	0.715	0.272	0.190	0.617	0.569	0.272	0.190	0.617	0.569	0.394	1.000
	1/4	1.65	0.484	0.190	0.131	0.626	0.546	0.190	0.131	0.626	0.546	0.398	1.000
	3/16												

Angles in shaded rows may not be readily available. Availability is subject to rolling accumulation and geographical location, and should be checked with material suppliers.

APPENDIX - E



COLUMNS
W shapes
Allowable axial loads in kips

$F_y = 36 \text{ ksi}$
 $F_y = 50 \text{ ksi}$

Designation	WT4									
	132	132	132	132	132	132	132	132	132	132
F_y	658	1101	1594	2178	2762	3346	3930	4514	5098	5682
U	2.47	2.47	2.47	2.47	2.47	2.47	2.47	2.47	2.47	2.47
P_{ax} (kips)	136	272	408	544	680	816	952	1088	1224	1360
P_{ax} (kips/in)	23	46	69	92	115	138	161	184	207	230
P_{ax} (kips)	587	692	797	902	1007	1112	1217	1322	1427	1532
P_{ax} (kips)	239	332	425	518	611	704	797	890	983	1076
L_c (ft)	15.5	13.2	11.0	8.8	6.6	4.4	2.2	0.0	0.0	0.0
L_u (ft)	47.7	34.4	21.1	17.8	14.5	11.2	7.9	4.6	1.3	0.0
A (in ²)	32.8	35.3	37.8	40.3	42.8	45.3	47.8	50.3	52.8	55.3
I_x (in ⁴)	1530	1380	1230	1080	930	780	630	480	330	180
I_y (in ⁴)	548	485	422	359	296	233	170	107	44	0
r_x (in.)	3.76	3.74	3.72	3.70	3.68	3.66	3.64	3.62	3.60	3.58
r_y (in.)	1.67	1.67	1.67	1.67	1.67	1.67	1.67	1.67	1.67	1.67
Ratio r_x/r_y	0.186	0.186	0.186	0.186	0.186	0.186	0.186	0.186	0.186	0.186
B_x } Bending	28.0	204.8	165.1	148.9	132.7	116.5	100.3	84.1	67.9	51.7
B_y } Factors	81.7	73.6	66.3	59.7	53.1	46.5	40.0	33.4	26.9	20.3
λ_x/r_x	409	404	401	401	401	401	401	401	401	401
λ_y/r_y	147	145	144	144	144	144	144	144	144	144
F_{cr} (K ₁ L ₁) ² /r ² (kips)										
F_{cr} (K ₁ L ₁) ² /r ² (kips)										

1 Flange is noncompact; see discussion preceding column load table.

American Institute of Steel Construction

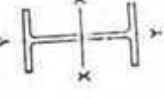

COLUMNS
W shapes
Allowable axial loads in kips

$F_y = 36 \text{ ksi}$
 $F_y = 50 \text{ ksi}$

Designation	WT4									
	132	132	132	132	132	132	132	132	132	132
F_y	658	1101	1594	2178	2762	3346	3930	4514	5098	5682
U	2.47	2.47	2.47	2.47	2.47	2.47	2.47	2.47	2.47	2.47
P_{ax} (kips)	136	272	408	544	680	816	952	1088	1224	1360
P_{ax} (kips/in)	23	46	69	92	115	138	161	184	207	230
P_{ax} (kips)	587	692	797	902	1007	1112	1217	1322	1427	1532
P_{ax} (kips)	239	332	425	518	611	704	797	890	983	1076
L_c (ft)	15.5	13.2	11.0	8.8	6.6	4.4	2.2	0.0	0.0	0.0
L_u (ft)	47.7	34.4	21.1	17.8	14.5	11.2	7.9	4.6	1.3	0.0
A (in ²)	32.8	35.3	37.8	40.3	42.8	45.3	47.8	50.3	52.8	55.3
I_x (in ⁴)	1530	1380	1230	1080	930	780	630	480	330	180
I_y (in ⁴)	548	485	422	359	296	233	170	107	44	0
r_x (in.)	3.76	3.74	3.72	3.70	3.68	3.66	3.64	3.62	3.60	3.58
r_y (in.)	1.67	1.67	1.67	1.67	1.67	1.67	1.67	1.67	1.67	1.67
Ratio r_x/r_y	0.186	0.186	0.186	0.186	0.186	0.186	0.186	0.186	0.186	0.186
B_x } Bending	28.0	204.8	165.1	148.9	132.7	116.5	100.3	84.1	67.9	51.7
B_y } Factors	81.7	73.6	66.3	59.7	53.1	46.5	40.0	33.4	26.9	20.3
λ_x/r_x	409	404	401	401	401	401	401	401	401	401
λ_y/r_y	147	145	144	144	144	144	144	144	144	144
F_{cr} (K ₁ L ₁) ² /r ² (kips)										
F_{cr} (K ₁ L ₁) ² /r ² (kips)										

American Institute of Steel Construction

FILES

 I_x, I_y

state the selection with respect to

of moment of inertia that are the

() equal to or greater value, and all member selected forming its spe-

UAP/CE417/FINAL/SP07/11

MOMENT OF INERTIA SELECTION TABLE
For W and M shapes

Shape	I_x in. ⁴	Shape	I_x in. ⁴	Shape	I_x in. ⁴	Shape	I_x in. ⁴
W 35 x 848	67400	W 44 x 248	21400	W 40 x 167	11600	W 33 x 118	5900
W 36 x 798	67600	W 30 x 391	20700	W 33 x 201	11300	W 30 x 132	5770
W 40 x 655	55300	W 27 x 418	20400	W 36 x 182	13000	W 24 x 176	5650
W 36 x 720	55300	W 36 x 309	20300	W 27 x 253	10800	W 27 x 156	5630
W 40 x 593	54300	W 40 x 295	19500	W 21 x 364	10000	W 18 x 258	5510
W 36 x 650	42900	W 33 x 318	19500	W 14 x 605	10800	W 14 x 370	5440
W 40 x 531	44300	W 44 x 224	19200	W 24 x 305	10700	W 30 x 124	5360
W 36 x 583	43500	W 40 x 244	19200	W 21 x 201	10500	W 21 x 201	5310
W 33 x 619	41800	W 24 x 492	19100	W 30 x 170	10300	W 24 x 162	5170
W 40 x 480	35800	W 36 x 280	18900	W 40 x 149	8760	W 30 x 116	4930
W 36 x 527	33500	W 30 x 357	18600	W 36 x 163	8750	W 19 x 234	4920
W 33 x 587	31700	W 27 x 437	18100	W 27 x 235	8560	W 14 x 342	4800
W 40 x 436	34700	W 33 x 291	17700	W 21 x 333	9510	W 27 x 129	4760
W 36 x 485	32700	W 36 x 260	17300	W 24 x 279	8500	W 21 x 182	4730
W 33 x 515	31200	W 24 x 450	17100	W 14 x 550	5430	W 24 x 145	4550
W 30 x 581	31200	W 30 x 326	16800	W 33 x 163	5290	W 30 x 151	5170
W 40 x 397	30200	W 44 x 198	16700	W 36 x 150	5040	W 30 x 108	4470
W 36 x 439	31300	W 40 x 215	16700	W 27 x 217	6370	W 18 x 211	4330
W 33 x 458	30100	W 40 x 221	16600	W 24 x 250	6490	W 14 x 311	4330
W 30 x 525	26300	W 36 x 245	16100	W 21 x 300	6480	W 21 x 165	4250
W 40 x 362	26200	W 27 x 368	16100	W 14 x 500	6210	W 27 x 114	4090
W 36 x 393	27500	W 33 x 263	15800	W 30 x 173	6200	W 12 x 336	4060
W 33 x 424	25500	W 24 x 408	15100	W 33 x 152	6100	W 24 x 131	4020
W 40 x 328	26500	W 36 x 230	15000	W 27 x 194	7330		
W 36 x 424	25500	W 40 x 199	14900	W 36 x 135	7500	W 30 x 99	3990
W 40 x 277	25100	W 27 x 336	14500	W 24 x 229	7500	W 18 x 192	3970
W 36 x 477	25100	W 14 x 730	14300	W 21 x 275	7520	W 14 x 283	3540
W 40 x 324	25500	W 40 x 192	13900	W 33 x 141	7450	W 21 x 147	3500
W 27 x 535	24500	W 21 x 373	13400	W 14 x 455	7190	W 30 x 90	3620
W 36 x 355	24500	W 40 x 193	13200	W 27 x 178	6300	W 14 x 43	425
W 44 x 285	24500	W 36 x 210	13100	W 18 x 311	6260	W 27 x 105	5920
W 40 x 298	24200	W 30 x 261	13100	W 24 x 207	6320	W 12 x 355	5550
W 40 x 297	23500	W 27 x 307	12800	W 21 x 248	6100	W 24 x 117	3540
W 36 x 433	23500	W 33 x 221	12400	W 18 x 175	3450	W 18 x 175	3450
W 27 x 434	22100	W 14 x 665	12400	W 14 x 257	3400	W 14 x 257	3400
W 25 x 328	22500	W 21 x 402	12200	W 33 x 130	6710	W 27 x 94	3270
W 40 x 277	21500	W 36 x 194	12100	W 30 x 148	6580	W 21 x 132	3220
W 33 x 554	21500	W 27 x 281	11900	W 14 x 426	6500	W 12 x 279	3110
W 40 x 258	21500	W 24 x 335	11900	W 24 x 152	6360	W 24 x 104	3100
W 40 x 258	21500	W 30 x 235	11700	W 18 x 233	6160	W 18 x 158	3060
				W 14 x 338	6000	W 14 x 233	3010
				W 21 x 223	5550	W 24 x 103	3000
				W 21 x 122	2560		

AMERICAN INSTITUTE OF STEEL CONSTRUCTION

MOMENT OF INERTIA SELECTION TABLE
For W and M shapes

Shape	I_x in. ⁴	Shape	I_x in. ⁴	Shape	I_x in. ⁴	Shape	I_x in. ⁴
W 27 x 84	2950	W 21 x 50	994	W 16 x 26	301	M 12 x 10	61.6
W 18 x 143	2750	W 18 x 60	954	W 14 x 30	291	W 10 x 12	53.9
W 12 x 252	2720	W 16 x 67	954	W 12 x 35	285	W 8 x 25	53.4
W 24 x 94	2700	W 12 x 106	933	W 10 x 49	272	W 8 x 15	48.0
W 21 x 111	2670	W 18 x 55	890	W 8 x 67	272	W 6 x 20	41.4
W 18 x 211	2660	W 14 x 62	852	W 10 x 45	248	W 6 x 13	39.6
W 18 x 130	2460					M 6 x 23	29.0
W 21 x 101	2420	W 21 x 44	843	W 14 x 26	245	M 10 x 9	39.8
W 12 x 230	2420	W 18 x 96	833	W 12 x 30	238		
W 14 x 193	2400	W 15 x 50	803	W 8 x 59	223	M 10 x 8	34.5
		W 14 x 74	795	W 10 x 39	209		
W 24 x 84	2372	W 15 x 57	750			M 10 x 7.5	32.8
W 18 x 119	2195	W 13 x 87	743	W 12 x 26	204	W 6 x 15	32.1
W 14 x 176	2142	W 14 x 68	723			W 5 x 10	30.8
W 12 x 210	2142	W 10 x 112	716			W 6 x 15	29.3
		W 18 x 45	712	W 14 x 22	199	W 5 x 19	29.2
W 24 x 76	2100	W 12 x 79	682	W 8 x 48	154	M 5 x 18.9	24.1
W 21 x 93	2070	W 15 x 50	659	W 6 x 12	221	W 6 x 12	22.1
W 18 x 106	1910	W 14 x 61	640	W 10 x 33	170	W 5 x 16	21.3
W 14 x 159	1900	W 10 x 100	603	W 10 x 33	170		
W 12 x 190	1892					M 6 x 6.5	18.5
						W 6 x 9	16.4
W 24 x 68	1830	W 15 x 40	612	W 12 x 22	156	W 4 x 13	11.3
W 18 x 83	1750	W 12 x 72	587				
W 18 x 97	1750	W 15 x 45	559	M 14 x 18	148	M 6 x 4.4	7.2
W 14 x 145	1710	W 14 x 53	541	W 8 x 40	145		
W 12 x 170	1650	W 10 x 65	532	W 10 x 25	144		
W 21 x 73	1500	W 12 x 65	533	W 12 x 19	130		
				W 8 x 35	127		
W 24 x 62	1550	W 16 x 40	518	W 10 x 22	118		
W 18 x 65	1530			W 8 x 31	110		
W 14 x 132	1530						
W 16 x 100	1490	W 15 x 35	510	W 12 x 16	123		
W 21 x 68	1490	W 14 x 49	485	W 8 x 25	95.0		
W 12 x 152	1430	W 12 x 59	475	W 10 x 19	95.3		
W 14 x 120	1380	W 10 x 77	455	W 12 x 14	83.2		
		W 15 x 35	445	W 8 x 24	82.8		
W 24 x 55	1350	W 14 x 43	425	W 12 x 17	81.2		
W 18 x 62	1330	W 12 x 53	425	W 5 x 21	75.3		
W 16 x 75	1330	W 12 x 50	394				
W 10 x 69	1330	W 10 x 69	394				
W 14 x 109	1240	W 14 x 38	365				
W 12 x 136	1240						
W 21 x 57	1170	W 16 x 31	375	M 12 x 11.8	71.9		
W 18 x 71	1170	W 12 x 45	350	W 10 x 15	68.9		
W 16 x 77	1110	W 10 x 60	341				
W 14 x 99	1110	W 14 x 34	340				
W 18 x 65	1070	W 12 x 40	310	M 12 x 10.8	65.0		
W 12 x 120	1070	W 10 x 54	303	W 5 x 18	61.9		
W 14 x 90	999						

AMERICAN INSTITUTE OF STEEL CONSTRUCTION

APPENDIX-7

97

46

Appendix-8

W SHAPES Properties

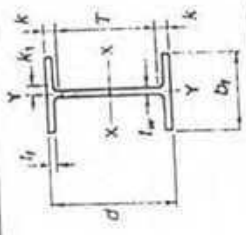

Nominal Wt. per Ft. Lb.	Compact Section Criteria			Elastic Properties						Plastic Modulus		
	$\frac{b_1}{2t}$	F_y Ksi	$\frac{d}{t_w}$	r_f In.	Axis X-X		Axis Y-Y		Z_x In. ³	Z_y In. ³		
					I In. ⁴	S In. ³	I In. ⁴	S In. ³				
492	2.0	—	15.1	3.80	19100	1290	11.5	1670	237	3.41	1550	375
450	2.1	—	16.1	3.76	17100	1170	11.4	1490	214	3.36	1410	337
408	2.3	—	17.3	3.71	15100	1060	11.3	1320	191	3.33	1250	300
370	2.5	—	18.4	3.67	13400	957	11.1	1160	170	3.28	1120	267
335	2.7	—	19.9	3.63	11900	864	11.0	1030	152	3.23	1020	238
306	2.9	—	21.5	3.60	10700	789	10.9	919	137	3.20	922	214
279	3.2	—	23.0	3.57	9600	718	10.8	823	124	3.17	835	193
250	3.5	—	25.3	3.53	8490	644	10.7	724	110	3.14	744	171
229	3.8	—	27.1	3.51	7650	588	10.7	651	99.4	3.11	676	154
207	4.1	—	29.6	3.48	6820	531	10.6	578	88.8	3.08	606	137
192	4.4	—	31.4	3.46	6260	491	10.5	530	81.8	3.07	559	126
176	4.8	—	33.7	3.44	5690	450	10.5	479	74.3	3.04	511	115
162	5.3	—	35.5	3.45	5170	414	10.4	443	68.4	3.05	468	105
146	5.9	—	38.1	3.43	4580	371	10.3	391	60.5	3.01	418	93.2
131	6.7	—	40.5	3.40	4020	329	10.2	340	53.0	2.97	370	81.5
117	7.5	—	44.1	3.37	3540	291	10.1	297	46.5	2.94	327	71.4
104	8.5	58.5	48.1	3.35	3100	258	10.1	259	40.7	2.91	289	62.4
103	4.6	—	44.6	3.32	3000	245	9.96	119	26.5	1.99	280	41.5
94	5.2	—	47.2	3.30	2700	222	9.87	109	24.0	1.98	254	37.5
84	5.9	—	51.3	3.23	2370	196	9.79	94.4	20.9	1.95	224	32.6
76	6.6	—	54.4	3.29	2100	176	9.69	82.5	18.4	1.92	200	28.6
68	7.7	—	57.2	3.26	1830	154	9.55	70.4	15.7	1.87	177	24.5
62	6.0	—	55.2	3.23	1550	131	9.23	34.5	9.80	1.38	153	15.7
55	6.9	—	59.7	3.18	1350	114	9.11	29.1	8.30	1.34	134	13.3

Application refer to Notes in 1
In shaded rows are not av

AMERICAN INSTITUTE OF STEEL CONSTRUCTION

AMERICAN

47

W SHAPES Dimensions

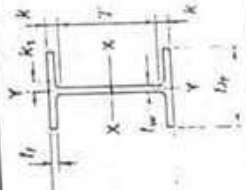

Designation	Area A In.	Depth d In.	Web		Flange		Distance		
			Thickness t_w In.	$\frac{L_w}{2}$ In.	Width b_f In.	Thickness t_f In.	T In.	k In.	k_1 In.
W 24 x 492 ^b	144.0	29.55	1.970	2	14.115	3.540	21	4 1/8	1 1/8
x 450 ^b	132.0	29.09	1.810	1 1/4	13.955	3.270	21	4 1/8	1 1/8
x 408 ^b	119.0	28.54	1.650	1 1/8	13.800	2.990	21	3 3/8	1 1/8
x 370 ^b	108.0	27.99	1.520	1 1/8	13.660	2.720	21	3 3/8	1 1/8
x 335 ^b	98.4	27.52	1.390	1 1/8	13.520	2.480	21	3 3/8	1 1/8
x 306 ^b	89.8	27.13	1.260	1 1/8	13.405	2.260	21	3 3/8	1 1/8
x 279 ^b	82.0	26.73	1.160	1 1/8	13.305	2.090	21	2 1/2	1 1/8
x 250 ^b	73.5	26.34	1.040	1 1/8	13.185	1.890	21	2 1/2	1 1/8
x 229 ^b	67.2	26.02	0.960	1 1/8	13.110	1.730	21	2 1/2	1 1/8
x 207 ^b	60.7	25.71	0.870	1 1/8	13.010	1.570	21	2 1/2	1 1/8
x 192 ^b	56.3	25.47	0.810	1 1/8	12.950	1.460	21	2 1/2	1 1/8
x 176 ^b	51.7	25.24	0.750	1 1/8	12.890	1.340	21	2 1/2	1 1/8
x 162 ^b	47.7	25.00	0.705	1 1/8	12.855	1.220	21	1 1/2	1 1/8
x 146 ^b	43.0	24.74	0.650	1 1/8	12.900	1.090	21	1 1/2	1 1/8
x 131 ^b	38.5	24.48	0.605	1 1/8	12.855	0.960	21	1 1/2	1 1/8
x 117 ^b	34.4	24.28	0.550	1 1/8	12.800	0.850	21	1 1/2	1 1/8
x 104 ^b	30.6	24.06	0.500	1 1/8	12.750	0.750	21	1 1/2	1 1/8
W 24 x 103 ^b	30.3	24.53	0.550	1 1/8	9.000	0.980	1	1 1/2	1 1/8
x 94	27.7	24.31	0.515	1 1/8	9.065	0.875	1	1 1/2	1 1/8
x 84	24.7	24.10	0.470	1 1/8	9.020	0.770	1	1 1/2	1 1/8
x 76 ^c	22.4	23.92	0.440	1 1/8	8.990	0.680	1	1 1/2	1 1/8
x 68	20.1	23.73	0.415	1 1/8	8.965	0.585	1	1 1/2	1 1/8
W 24 x 62	16.2	23.74	0.430	1 1/8	7.040	0.590	1	1 1/2	1 1/8
x 55	16.2	23.57	0.395	1 1/8	7.005	0.505	1	1 1/2	1 1/8

^bFor application refer to Notes in Table 2.
^cHeavier shapes in this series are available from some producers.

AMERICAN INSTITUTE OF STEEL CONSTRUCTION

UAP/CE 4171 FINAL/3007/12

6

90

The University of Asia Pacific
Department of Civil Engineering
Final Examination Spring 2007

Course# CE 433
Full Marks: 100

Course Title: Environmental Engineering-IV
Time: 2 Hours

There are Seven questions, Answer any Five

- Q1. (a) Describe the mobilization of arsenic in ground water of Bangladesh. (9)
(b) Schematically show removal mechanism of arsenic from water by (6)
(i) Oxidation and
(ii) Coagulation-adsorption-coprecipitation.
(b) What are the principal carcinogenic and non-carcinogenic health effects that may (5)
result from exposure to arsenic?
- Q2. (a) A lake with surface area equal to $15 \times 10^6 \text{ m}^2$ is fed by a stream having an average (13)
flow of $13 \text{ m}^3/\text{s}$ and an average total phosphorus concentration of 0.015 mg/L . In
addition, treated effluent from a wastewater treatment plant adds $0.24 \text{ m}^3/\text{s}$ of flow
having 8.0 mg/L total phosphorus. The phosphorus settling rate is estimated as 9.5
 m/yr .
(i) Estimate the average total phosphorus concentration.
(ii) What rate of phosphorus removal at the treatment plant would be required to
keep the concentration of phosphorus in the lake at the acceptable level of
 0.01 mg/L ?
(b) Define eutrophication. What do you understand by Oligotrophic and Eutrophic (7)
lake?
- Q3. (a) Give an example of bioaccumulation and biomagnification. (6)
(b) Write short note on thermal pollution of water. (4)
(c) Explain natural die-off of organisms in natural water bodies. (4)
(d) What are the major sources of nutrients in water bodies? Describe the effects of (6)
nutrient enrichment in water bodies.
- Q4. (a) Describe the mechanism of particulate collection in the respiratory system of (5)
human being.
(b) What is aerodynamic diameter? Why particle size of $2\text{-}5 \mu\text{m}$ is very important? (5)
(c) Mention BECR-1997 Air Quality Standards (for commercial and mixed area) and (5)
compare this with U.S.A. Standards.
(d) Describe health effect of CO. (5)
- Q5. (a) How air pollution can be removed using fabric filter technique? (5)
(b) What are the control devices for particulate and gaseous pollutants in atmosphere? (6)
Define adsorption and absorption.
(c) Describe the operating principles of cyclone collector and gravitational settling (9)
chamber.

- Q6. (a) Define lapse rate. What do you understand by “unstable” atmosphere? Draw the shapes of fumigating, coning, looping and funning plumes and the corresponding temperature structure. Also comment on the pollution potential of each plume. (9)
- (b) Define two types of inversion. (3)
- (c) What are the assumptions of point-source Gaussian plume model? Define maximum mixing depth. How can we calculate maximum mixing depth? (8)
- Q7. (a) What do you understand by Thermal NO_x and Fuel NO_x ? (4)
- (b) What are the anthropogenic sources of NO_x in the atmosphere? (4)
- (c) According to USEPA, air-quality standard for CO is 9.0ppm (at 1 atm, 25°C). Express the standard in $\mu\text{g}/\text{m}^3$. (4)
- (d) Describe the formation mechanism of SO_x in the atmosphere. Describe the effects of SO_x on materials. (8)

49

The University of Asia Pacific
Department of Civil Engineering
Final Examination Spring 2007

Course # CE 439
Full Marks: 75

Course Title: Environmental Engineering VII
Time: 2 hours

There are **Seven (7)** questions. Answer any **Five (5)**.

- Q1. a) Write down the importance of conducting EIA in Bangladesh context. (6)
b) Describe the characteristics of impacts in various dimensions. (9)
- Q2. a) Define Environment and Ecosystem. How is environmental balance maintained and what are the causes of disruption of environmental balance? (3+4+4)
b) Define Scoping. (4)
- Q3. a) What is the legal framework of conducting EIA in Bangladesh? (6)
b) Describe the causes and effects of Ozone Layer Depletion. (9)
- Q4. a) What is Environmental Monitoring? Why is it necessary in EIA process? Explain. (6)
b) A 5 Km urban road is proposed to build connecting Tongi diversion road and Rampura area to ease traffic congestion. For this a portion of existing wetland will be filled up and a number of settlements will be evicted. Identify the possible impacts due to this project. (9)
- Q5. a) Why is people's participation desirable in EIA? State the objectives of people's participation. (6)
b) What are the major water quality problems? Describe the sources and adverse impacts due to organic pollution in water. (9)
- Q6. a) What is a baseline study? Describe the role of baseline studies in EIA. (6)
b) The construction of a bridge is undertaken in rural areas to facilitate communication and commerce. Identify the potential ecological impacts for this project and recommend some mitigation measures to overcome negative impacts. (9)
- Q7. a) Describe different levels of Environmental Auditing. (7)
b) Name the common EIA methodologies. How can you evaluate impacts in Environmental Evaluation System (EES)? Explain. (8)

6. (a) What are the most important properties of aggregate for highway construction? List the laboratory tests, in different groups, of bituminous materials used in road construction. (8)
- (b) What are the advantages of flexible pavement? (6)
- (c) For the following data, design and draw the distributed reinforcement and tie bars for a rigid pavement: (11)
- Thickness of the rigid pavement= 8 inch
 Lane width= 12 ft, two lane
 Spacing of the transverse joint=45 ft
 Allowable stress of steel =20000 psi
 Compressive strength of concrete= 3650 psi, $f = 1.5$
- 7 (a) Explain "Pavement Serviceability Concept." (5)
- (b) What are the salient features of the design of flexible pavement by the Asphalt Institute method? (8)
- (c) Write down the purpose, materials and construction methods of prime coat and seal coat. (4)
- (d) What are the difference between bituminous road mix and plant mix surface? (4)
- 8 (a) What do you mean by "pumping of joints"? How does pumping occur in rigid pavement? How can we prevent pumping action? (9)
- (b) What is cutback asphalt? (3)
- (c) Design a minimum thickness of flexible pavement (i.e. thickness of different layers) for the following traffic condition: (13)

Daily Count	Axle load (kips)	ESAL Factor
2000 (Single Axle)	8	0.04
2000 (Single Axle)	15	0.10
100(Single Axle)	32	8.8
100 (Tandem Axle)	48	10

Given:

Sub grade soil CBR value is 6

Design life is 10 years

Traffic growth rate is 6% per annum

Reliability is 90%

Overall standard deviation is 0.45

Design serviceability loss is 2.0

Available material:

- Hot mix asphalt surface concrete ($a_1=0.44$)
- Crushed stone base course ($a_2=0.14$, $m_2=0.4$ & $E_2= 30$ ksi)
- Crushed stone sub base ($a_3=0.11$, $m_3=0.9$ & $E_3= 14.5$ ksi)

Note: Use attached Fig. 1.



The University of Asia Pacific
Department of Civil Engineering
Final Examination Spring 2007

Course# CE 451
Full Marks: 150

Course Title: Transportation Engineering-II: Highway Design & Railways
Time: 3 hrs

There are two sections in the question paper namely "SECTION A" and "SECTION B". You have to answer from both sections according to the instruction mentioned in each section.

SECTION A

There are FOUR questions in this section. Answer any THREE.

1. (a) Write a short note on "Blanket Layer". (5)
(b) Elaborately explain different type of distresses in rigid and flexible pavement. Also discuss the causes of these distresses and relevant remedial measures. (20)
2. (a) What is gauge? Why is it desirable to use uniform gauges in a country? (2+5)
(b) What are the requirements of ideal sleepers? What are the functions of ballast? (6+6)
(c) Why is it necessary to provide the followings: (6)
(i) Bearing plates (ii) Level crossing
3. (a) What is meant by wear of rails? What are the different types of wear of rail? Mention precautions to be taken to reduce wear of rails. (3+4+4)
(b) Calculate the maximum permissible train load that can be pulled by a locomotive with 4 pairs of driving wheels having an axle load of 22 tons each on a straight level B.G. track at a speed of 70 kmph. Also calculate the reduction in speed if the train has to run on a rising gradient of 1 in 250. What would be the further reduction in speed if the train has to negotiate a 4° curve on the rising gradient? Assume coefficient of friction as 0.2. (10)
(c) Write a short note on transition curve. (4)
4. (a) What is coning of rails? What are the disadvantages of coning of wheels? (6.5)
(b) Explain expansion stress and warping stress development in rigid concrete pavement. (5)
(c) Discuss the classification of fixed signals. (7.5)
(d) State the function of (6)
(i) Railway station
(ii) Elastic spikes
(iii) Point and crossing.

SECTION B

There are FOUR questions in this section. Answer any THREE.

5. (a) How do you adjust the mix if stability, flow or voids in the mixture does not match in the Marshal Method of mix design? (8)
(b) What are the objectives of mix design? Name the three main steps for mix design. (5+3)
(c) Describe the fundamental properties of bituminous mixture. (6)
(d) Discuss the outcomes of AASHO Road Test. (3)



MONOGRAPH SOLVES:

$$\log_{10} W = Z_R S_0 + 9.36 \log_{10} (SN+1) - 0.20 + \frac{\log_{10} \left[\frac{\Delta \text{PSI}}{4.2 - 1.5} \right]}{1.094} + 2.32 \log_{10} M_R - 8.07$$

$$0.40 + \frac{1.094}{(SN+1)^{5.19}}$$

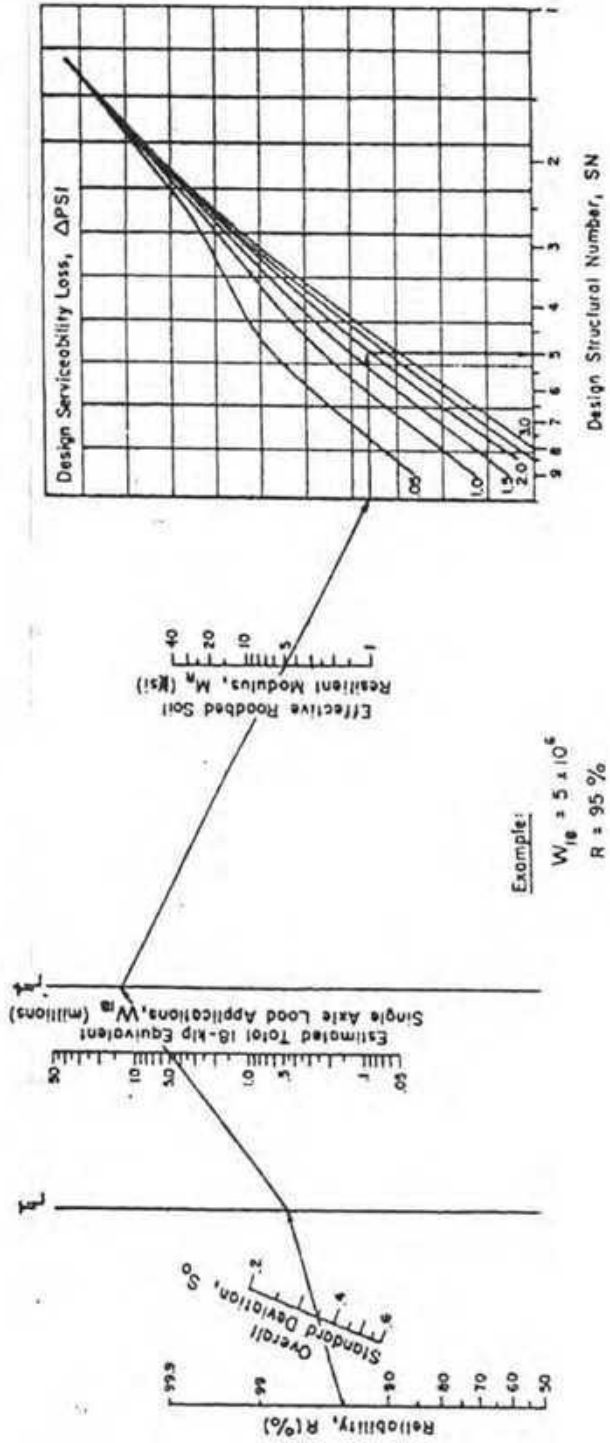

FIGURE 1 AASHTO design chart for flexible pavements based on using mean values for each input. (Courtesy American Association of Highway and Transportation Officials.)

54
(b) What is 'piping' in a hydraulic structure? What are the ill effects of piping and how to avoid these effects? (6)

(c) Design and sketch the shape of an Ogee type spillway for the following data using the empirical equation developed by US Army Corps Engineers:

Upstream Head, $H = 20$ m

Shape of the upstream face = 1 : 1.5 (H : V)

Values of K and n are 1.939 and 1.81 respectively (12)

5. (a) What are the causes of failure of a hydraulic structure? Name the different components of the barrage. (8)

(b) Using Khosla's curves, determine the following for the apron shown below:

(i) Uplift pressure at points C, E1 and D1 with necessary corrections

(ii) Exit gradient

Assume floor thickness = 1 m. (20)

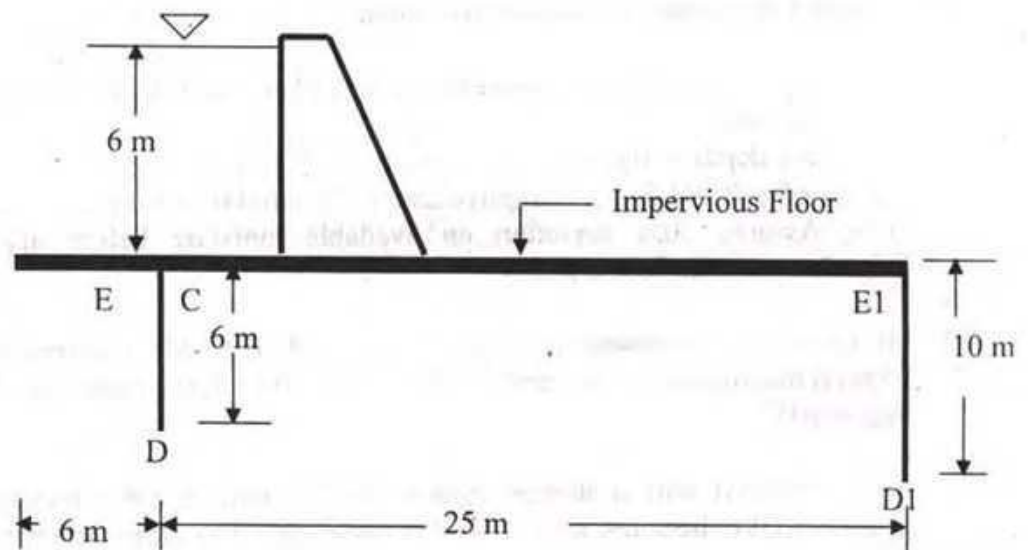

6. (a) What are the different types of pumps that can be used in irrigation purpose? (6)

(b) A centrifugal pump is required to lift water at the rate of 100 lit/sec. Calculate the horse power of the engine from the following data when the water is directly supplied to the field channel.

i) Suction head = 5 m

ii) Coefficient of friction = 0.01

iii) Efficiency of pump = 65%

iv) Diameter of pipe = 15 cm (12)

(c) Briefly discuss different structural and non-structural measures for flood management. (10)

The University of Asia Pacific
Department of Civil Engineering
Final Examination Spring 2007

Course No.: CEE 461

Course Title: Irrigation and Flood Control

Full Marks: 150

Time: 3 hours

Answer question no. 1 and any other FOUR

1. (a) Write short notes on (any Seven): (28)
- i) Weir and Barrage
 - ii) Head regulator and cross regulator
 - iii) Optimum Utilization of Irrigation water
 - iv) Aqueduct and Super passage
 - v) Alluvial and Non alluvial channel
 - vi) Importance of a Berm.
 - vi) Launching apron
 - vii) Soil-moisture-Irrigation relationship
 - viii) Level crossing and inlet and outlet
- (b) Compute the depth and frequency of irrigation required for a certain crop with data given below:
Root zone depth = 100cm; Field capacity = 22%; Wilting point = 12%; Specific gravity of soil = 1.5; Consumptive use = 25 mm/day; Efficiency of irrigation = 50%; Assume 50% depletion on available moisture before application of irrigation water at field capacity. (10)
2. (a) Derive the relationship between duty and delta for a given base period. Explain the influence of several factors, which affect duty. How can the duty be improved? (18)
- (b) A reservoir with a storage capacity of 300 million cubic meters is able to irrigate 40,000 hectares with 2 fillings each year. The crop season is 120 days. What is the duty? (10)
3. (a) Explain in details, as to how will you proceed for determining the approximate value of design discharge of an irrigation canal. (10)
- (b) The cultivable commanded area of a watercourse is 1200 hectares. Intensities of sugarcane and wheat crops are 20% and 40% respectively. The duties for the crops at the head of the watercourse are 730 hectares/cumec and 1800 hectares/cumec respectively. Find the discharge required at the head of the watercourse. (18)
4. (a) Explain the necessity of lining of canals. How will you justify economically the necessity of lining an existing canal? (10)

- 52
7. (a) What are the benefits of flood control? (6)
- (b) What are the different types of river bank protection? (12)
- (c) Distinguish between Spur and Groyne. (5)
- (d) Why canal fall is necessary? Name five different types of falls. (5)

SHEET PILE NOT AT END

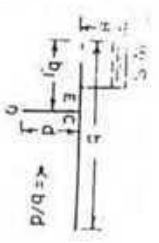

$$\Phi_e = (1/\pi) \cos^{-1} \left(\frac{\lambda_1 - 1}{\lambda} \right)$$

$$\Phi_c = (1/\pi) \cos^{-1} \left(\frac{\lambda_1 + 1}{\lambda} \right)$$

$$\Phi_o = (1/\pi) \cos^{-1} \left(\frac{\lambda_1}{\lambda} \right)$$

To find Φ_e for any value of α and base ratio b_1/b , read Φ_e for base ratio $(1 - b_1/b)$ for that value of α and subtract from 1.
 Thus, Φ_e for $b_1/b = 0.4$ and $\alpha = 4$, = $100 - \Phi_c$ for $b_1/b = 0.6$ and $\alpha = 4$, = $100 - 29.1 = 70.9\%$

To get Φ_o for values of b_1/b less than 0.5, read Φ_o for base ratio $(1 - b_1/b)$ and subtract from 100.
 Thus Φ_o for $b_1/b = 0.4$ and $\alpha = 4$
 = $100 - \Phi_c$ for $b_1/b = 0.6$ and $\alpha = 4$
 = $100 - 44.8 = 55.2$

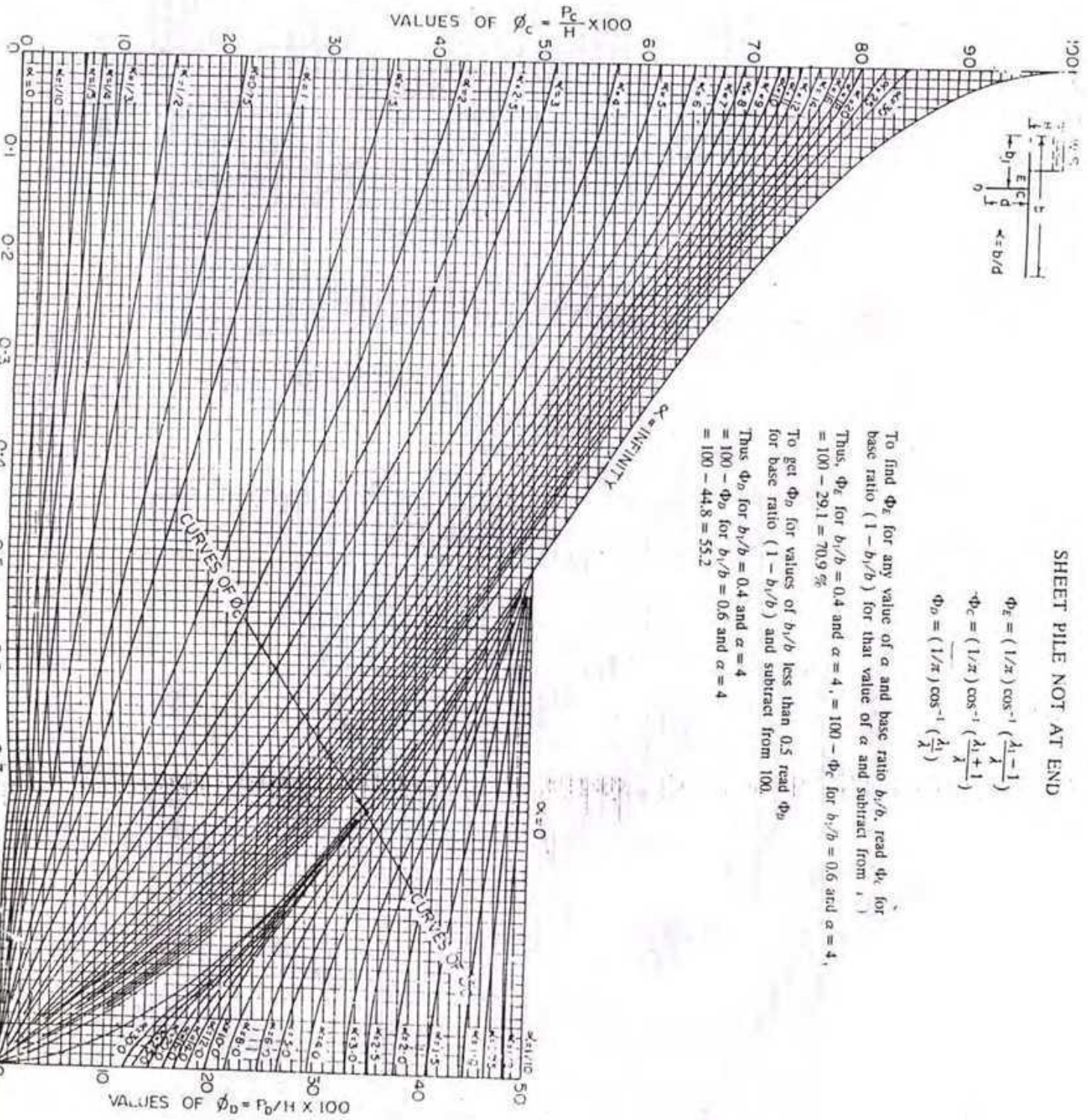

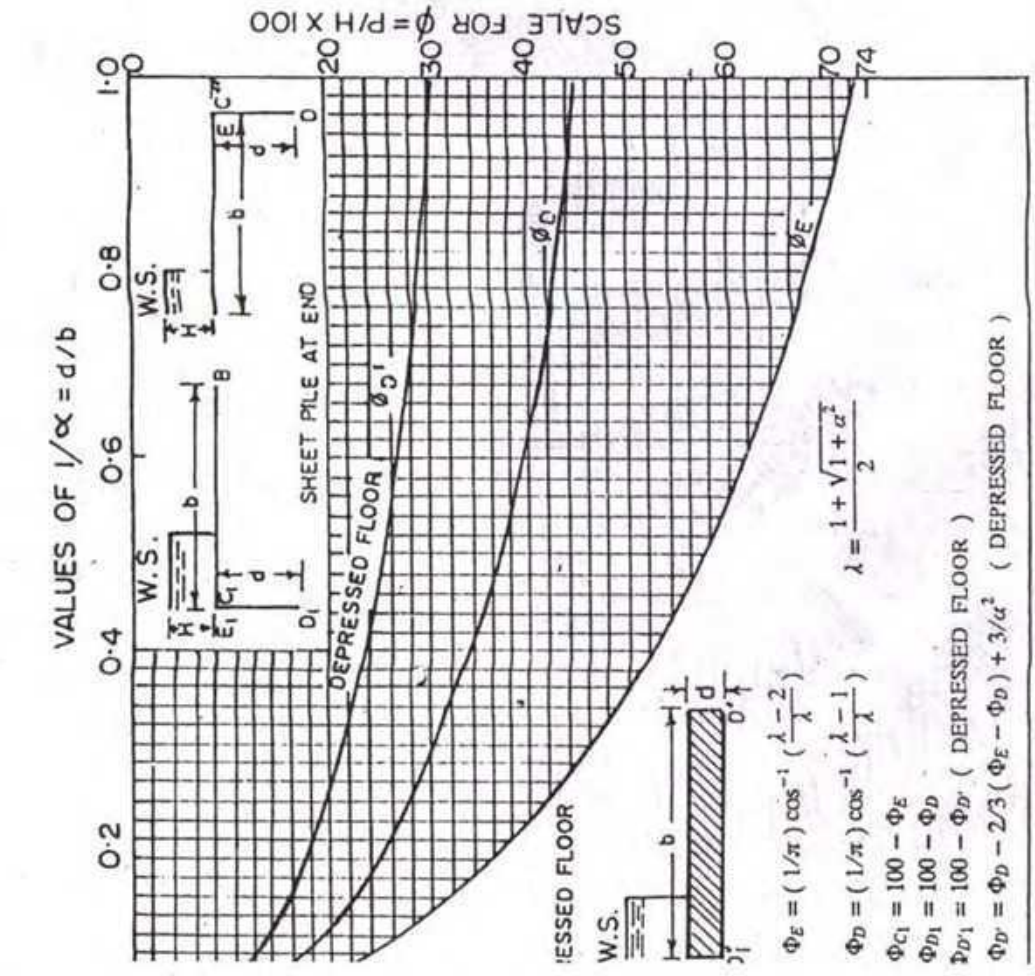
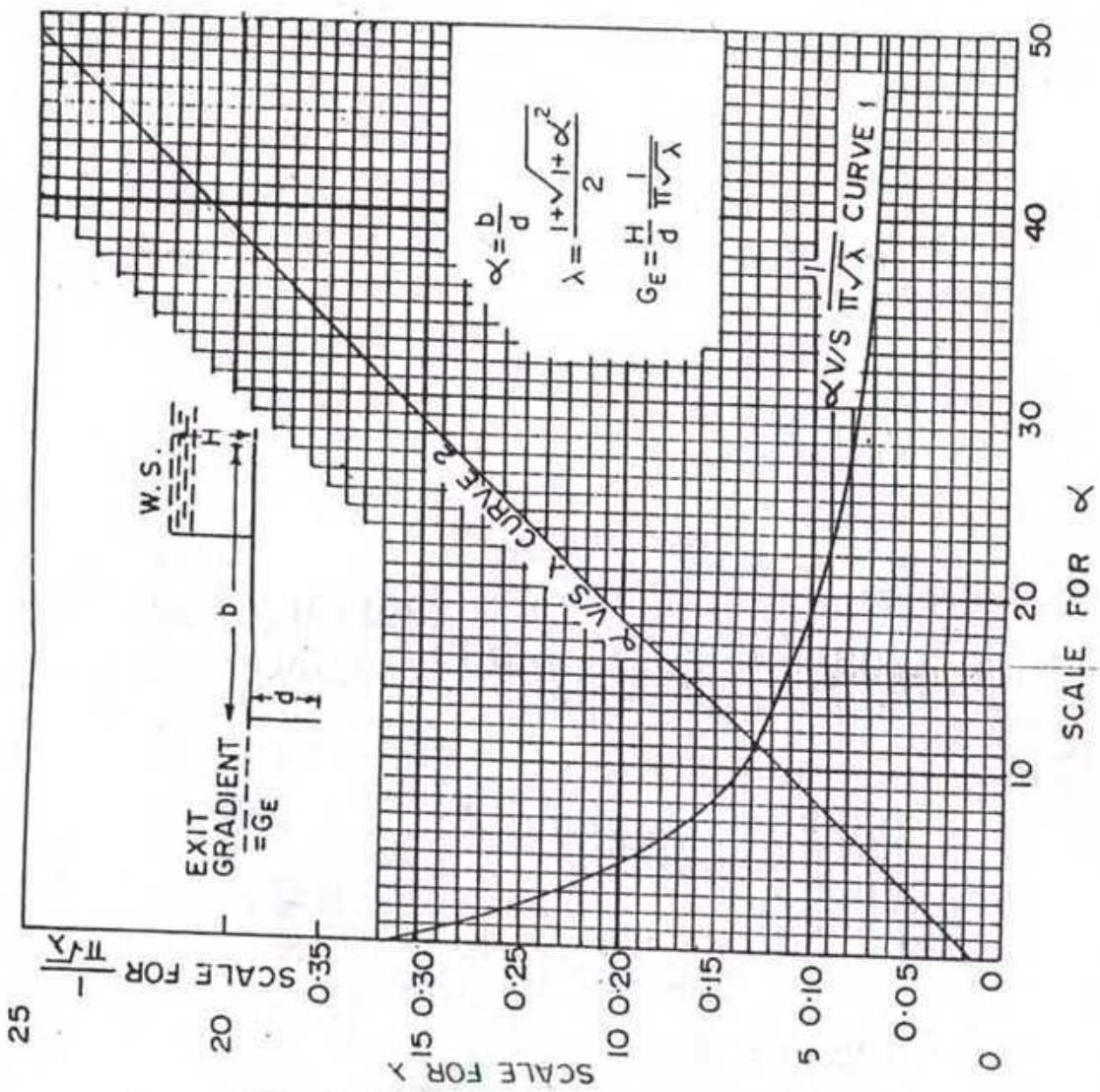

FIG. 12.13 (b) PLATE II KHOSLA'S CURVES

The University of Asia Pacific
Department of Civil Engineering
Final Examination, Spring 2007

Course No : CE 531

Credit Hour : 2.0

Time : 2 hours

Total Marks : 100

Answer all questions. Each question carry equal marks.

1.

- a. Suppose you have a map of your sales center (sales.shp) and you want to give a promotional prize to a sale center whose total daily sales volume is Tk. 61,842.00. Find out the name of the sales center. (Add **sales.shp** to your view)

Ans.

Name of the sale center is :

- b. Dhaka old Airport is situated in Tejgoan area (airport.shp). There are other 19 areas adjacent to the airport (Area 001, 002, etc.). As per the Aviation rule building cannot be constructed more than 20 ft within a circular area of radius 740000 miles taking center of the circle is X=539814 and Y=627818. (Add **airport.shp** to your view)

Find out the name of the **thana(s)** where you can construct building with height more than 20 ft.

Ans.

Thana Name: 1.....2.3.....4.....

- c. Suppose airport.shp map represents the area under Dhaka City. There are two major drainage lines will be constructed to ease the drainage congestion. The proposed lay out is given in drainage.shp. (Add **drainage.shp** to your view)

Find out the name of the **thana(s)**, which are not under drainage coverage as per the plan.

Thana Name: 1.....2.3.....4.....
5.....6.7.....8.....

- 2.
- a. Suppose you have a map of your sales center (sales.shp) in USA and you have also a USA states map (states.shp). (Add **states.shp** to your view)
Find out the
 - (a) How many sales centers are in "Washington" states.
 - (b) What is the total population under these sales center.
 - (c) If "population" is the most important criteria for selecting most potential sales center, then find out the name of the sales center.
 - (d) If "population" is the most important criteria for revenue collection, find out the name of the State that generates maximum revenue.
 - b. Suppose you want to construct a road between Dhaka and Chittangong (roads.shp). How many Districts and Upozillas are going to be affected due to the construction of the road. (add **thana.shp** to your view)
 - (i) No of Districts :.....
 - (ii) Name of the Districts :.....
 - c. In USA Four states namely California, North Carolina, Texas and South California are vulnerable to cyclone (states.shp). The number of population in these states are given in sales.shp (pop1990). If a severe cyclone is imminent then find out the total number of population to be evacuated from these four states. How many are males and how many are females?

Ans Total..... Male:..... Female:.....

- 3.
- a. There are Twelve States in Canada (canada.shp). The University of Asia Pacific wants to open twelve information centres in Canada (one centre at each state).

i. Create a point theme map that indicates the information centres and save the theme as information.shp.

ii. Add the following attributes to the newly created point theme.

Centre_ID	States Name	Addresses	Sate_population
12001	Quebec	XXX	152350
12002	N. Territories	YYY	254620
12003	Nova Scotia	ZZZ	356210
12004	Saskatchewan	AAA	236589
12005	Alberta	BBB	256870
12006	N. and Labrador	CCC	569810
12007	British Columbia	DDD	125894
12008	New Brunswick	EEE	159846
12009	P. E. Island	FFF	158920
120010	Y. Territories	GGG	156820
120011	Manitoba	HHH	158930
120012	Ontanio	MMM	148950

b. Suppose the shape of the Dhanmondi Lake is as follows, the three lines indicates three foot over bridges. Create the two themes and save as lake.shp and bridge.shp

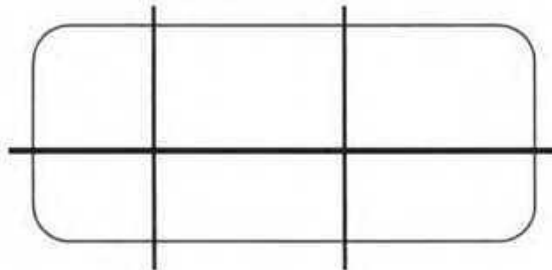

c. Dhaka is expanding every year (add dhaka.shp to your view) The area shown was five yeas earlier. RAJUK wants to acquire new lands to develop a model town. Create a new map with the help of existing map. The figures are shown below,

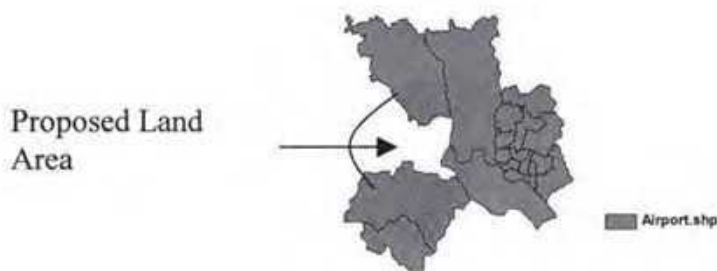

Save the file as "newdhaka.shp"

- d. Save the **dhaka.shp** as **division.shp** and Create Dhaka Division map with the help of "division.shp" map. Save the map as "division.shp".
- e. Save the **division.shp** as **east-west.shp** and spilt the map into two parts, Eastern and Western, and save the map as "**east-west.shp**".

4.

There are 51 states in USA. Before 9-11 FBI classify various states under three categories, Red – High Alert, Orange – Moderate Alert, Yellow – Low Alert and Green – Safe.

a. Create a map based on this four security codes and save the map as security.shp.

b. Prepare a layout showing the terror list map and save as a bitmap file.

c. How many states are under

- (i) Red terror code
- (ii) Yellow terror code
- (iii) Orange terror code
- (iv) Green terror code

d. How many people are under

- (i) Red terror code
- (ii) Yellow terror code
- (iii) Orange terror code
- (iv) Green terror code



7

The University of Asia Pacific
Department of Civil Engineering
Final Examination Spring 2007

Course # CHEM 111
Full Marks: 50

Course Title: Chemistry
Time: 3 hours

[Answer any FOUR questions. All questions carry equal marks]

1. (a) What is an atom according to Dalton's theory? 02
(b) Discuss the Rutherford solar system atom model. 03
(c) What are the limitations of Rutherford's atomic theory? 02
(d) What are the postulates of Bohr's atomic theory?
Mention the success and failure of Bohr's theory. 5.5
2. (a) What is dynamic equilibrium?
Give some examples of chemical and physical equilibria. 05
(b) The formation of ammonia by Haber Bosch process follows the following equilibrium reaction:
$$\text{N}_2(\text{g}) + 3\text{H}_2(\text{g}) \rightleftharpoons 2\text{NH}_3 + 92 \text{ kJ mol}^{-1}$$

What will be the effect of increase in pressure and decrease in temperature on this equilibrium? 04
(c) What is K_p ?
Find an expression for K_p of this equilibrium.
What will be its K_c ? 3.5
3. (a) What are enthalpy and enthalpy change?
Explain exothermic and endothermic reactions with suitable examples. 04
(b) What is standard enthalpy of formation?
Define standard enthalpy of neutralization. 03
(c) What is combustion?
Calculate the standard enthalpy of formation of benzene from the following data:
- | Substance | Formula | $\Delta H_c / \text{kJ mol}^{-1}$ |
|-----------|----------------------------------|-----------------------------------|
| Benzene | $\text{C}_6\text{H}_6(\text{l})$ | -3278 |
| Carbon | C (graphite) | -394 |
| Hydrogen | $\text{H}_2(\text{g})$ | -286 |
- 5.5

4. (a) What are rate and rate constant of a chemical reaction? Mention their units. 02
- (b) What is rate law?
Find an integrated rate equation for a simple second order reaction. 04
- (c) Define the order of a reaction.
Give an example of a zero-order reaction. 03
- (d) What is meant by the half-life of a chemical reaction?
Show that the half-life of a first order chemical reaction is independent of its initial concentration. 3.5
5. (a) What are solution and colloids?
How would you distinguish between them? 04
- (b) What is corrosion?
Discuss different types of corrosion. 04
- (c) Show that the rusting on steel is a redox process. 02
- (d) What are pollutants?
How do they play a detrimental effect on our environment? 2.5
6. (a) What are macromolecules?
What is a repeating unit?
Give some examples of natural and synthetic polymers. 03
- (b) What are polystyrene and polythene?
Mention their repeating units. 03
- (c) What are the uses of PVC and TEFLON? 02
- (d) What are paints and varnishes? 02
- (e) What are the different ingredients of paints?
Give one largescale use of paints. 2.5

19

The University of Asia Pacific
Department of Civil and Computer Sc. & Engineering
Final Examination Spring 2007

Course # IMG 301

Course Title: Principles of Management

Full Marks- 100

Time: 2 hours

Answer any 5(five) of the following questions. All questions are of equal value.

1. Define 'Management'. Discuss the managerial functions. "All managers carryout managerial functions, but the time spent for each function may differ"-explain.
2. Discuss the internal and external environment in which managers operate. What are the major social responsibilities of business managers? Discuss.
3. How can you distinguish between strategies and policies? Discuss the TOWS matrix for strategy formulation.
4. Define staffing. Discuss Human Resource Management (HRM) functions and show HRM Components.
5. Define leadership. Discuss the ingredients of leadership. Show managerial grid to describe managerial styles.
6. What do you mean by 'Time Management'? Point out the Time Management guidelines. Describe the process of 'Time Management'.
7. Write short note on any four of the following:
(a) MBO Process (b) Decision Making (c) Managerial Roles approach (d) Ethics in Business (e) Motivation (f) MIS.