

**The University of Asia Pacific**  
**Department of Civil Engineering**  
**Final Examination Spring 2008**  
**Program: B.Sc. Engineering (Civil)**

Course Title: Engineering Mechanics II  
 Time: 3.0 hours

Course Code: CE 103

Credit: 3.00  
 Full Marks: 150

There are **EIGHT** questions. Answer any **SIX**. The figures in the right margin indicate the marks of the questions.

- 1.(a) From the following figure, determine the tension in the cables and weight of B for impending downward motion of B. Weight of A = 350 lb,  $f_A = 0.33$  and  $f_B = 0.20$ . (12)

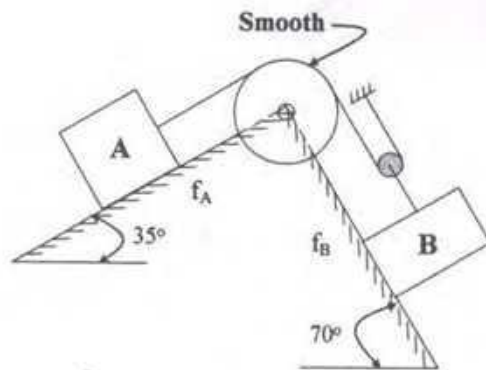

- 1.(b) As shown in the figure below, a resistance of 1200 lb is exerted on the block A, which in turn presses against the wedge B. Neglect the weight of blocks A and B and assume that  $f = \frac{1}{4}$  for all surfaces. What force Q will cause the wedge B to be in impending motion downward? (13)

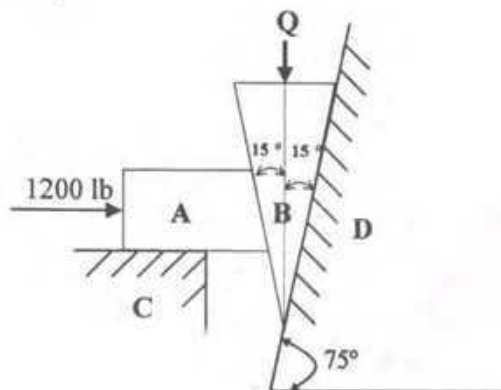

2.(a) Derive the relation between the tight tension and slack tension, i.e.,  $T_1 = T_2 e^{f\theta}$ . (10)

2.(b) In the following figure  $W_A = 1050$  lb.,  $f = 1/2$  and the pulleys C and D are to be considered frictionless and weightless. (a) If A moves 50 ft from rest up the incline in 10 sec., what is the weight  $W_B$  of the body B? (b) What are the forces in the cables attached to A and B? (c) What is the change of potential energy of A and B? (15)

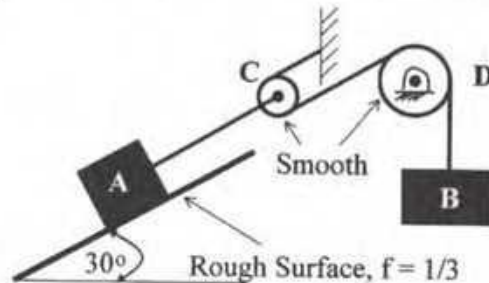

3.(a) A particle is moving with rectilinear motion. The displacement (ft) versus time (sec.) function of the particle is given below: (12)

$$S = 2t^2 + 5t + 10$$

Determine -

- the velocity vs time function and acceleration vs time function.
- the velocity, displacement and acceleration of the particle after 5 sec.  
Also determine the displacement of the particle in 5<sup>th</sup> sec.

3.(b) Refer to the following figure. All forces are in z direction. Determine the magnitude and location of the resultant force. (13)

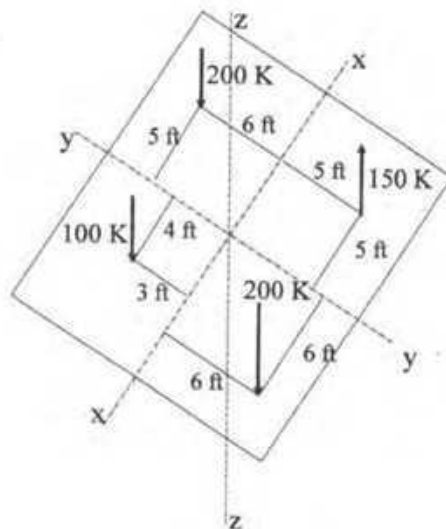

- 4.(a) A cylindrical jet of water from a nozzle with a velocity of 200 fps and at the absolute rate of 4.5 lb per sec enters a blade as shown in the following figure. (13)  
 Neglecting the frictional loss, determine the resultant force on the blade in magnitude and direction for the following conditions:  
 (i) when velocity of the blade,  $V_B = 0$  fps  
 (ii) when velocity of the blade,  $V_B = 100$  fps

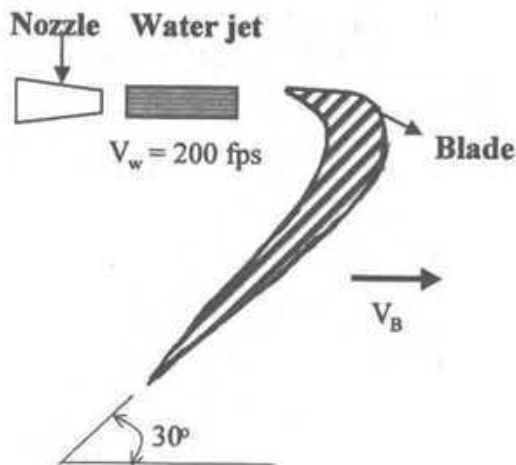

- 4.(b) As shown in the following figure, the weight  $W = 90$  lb is placed on a triangular table. Find the reactions at supports A, B and C. (12)

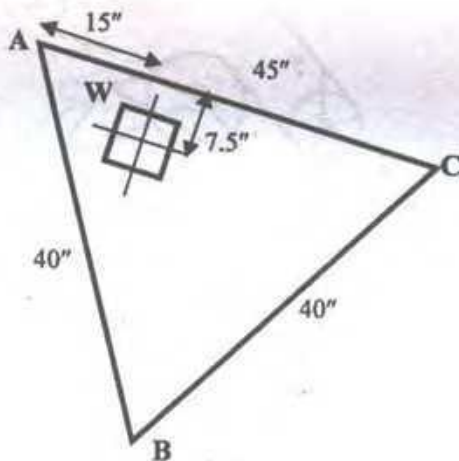

- 6
- 5.(a) Refer to the following figure, the initial velocity of A is 25 fps towards the right, find the time in seconds for A to travel 20 ft. (13)

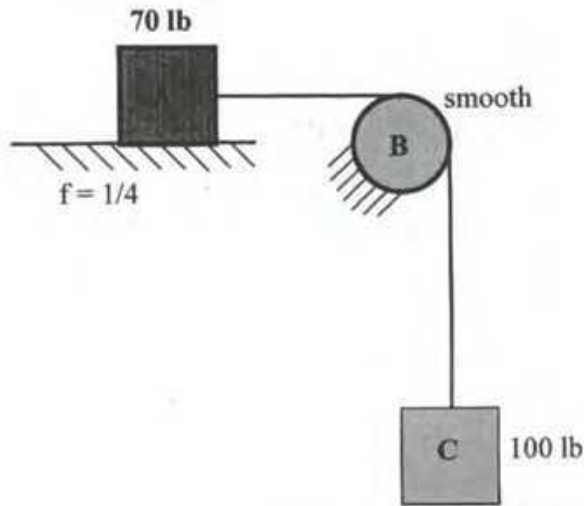

- 5.(b) A  $45^\circ$  sector of a cast iron disk with a radius of 20" is used to balance the reciprocating part of a certain engine as shown in the following figure. Find its mass moment of inertia about the z axis. Unit weight of cast iron is 450 lb/cft. (12)

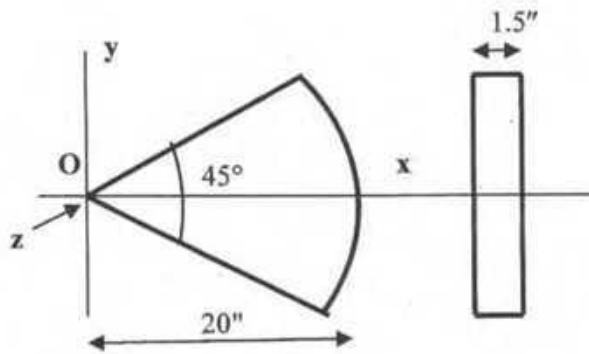

- 6.(a) Refer to the following figure. The speed of A changes from 20 fps to 70 fps in 30 sec. Determine (i) the weight of B, (ii) the distance moved by B in 30 sec, and (iii) the tension in the cable. (13)

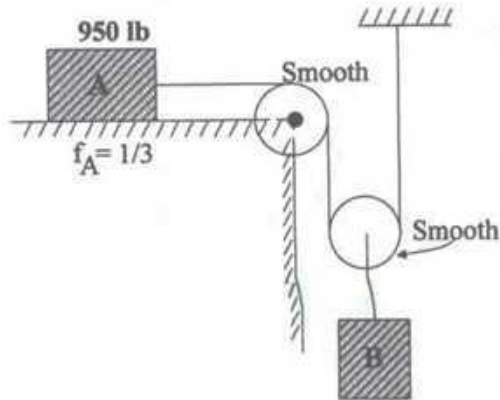

- 6.(b) In the following figure,  $W_A = 200$  lb.,  $W_B = 100$  lb.,  $f_A = 1/4$ , and  $f_B = 1/3$ . How far and in what direction does A travel from rest in 30 sec.? What are the tensions in the cables C and D? (12)

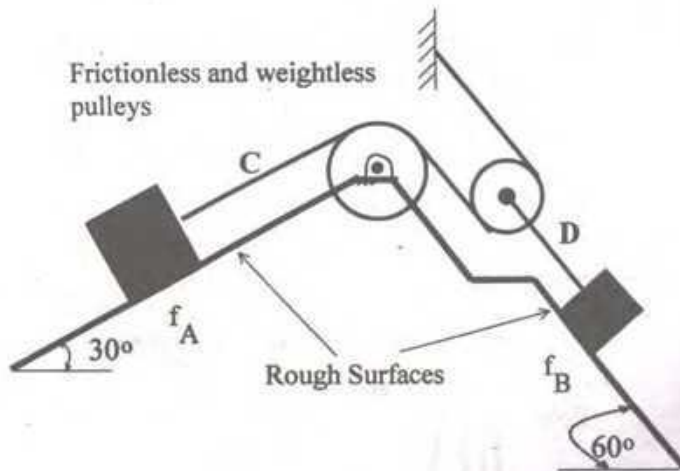

- 8
- 7.(a) The following figure represents a boom that supports a load  $W = 1000$  lb. If  $AB = BC = 6$  ft,  $BD = 5$  ft, and  $BE = 4$  ft., find the tension in cable  $DE$  and the force in members  $AE$  and  $CE$ . (13)

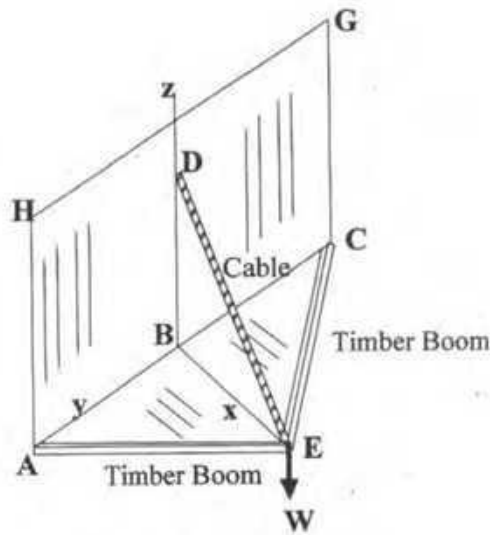

- 7.(b) Two cables  $A$  and  $B$  terminate on a pole as shown in the following figure and exert forces in the horizontal plane at  $C$ . The guy cable  $CD$  makes an angle  $\theta = 40^\circ$  with the pole and the anchor at  $D$  is to be so located that the pole will have only a compressive load. Let  $\alpha = 35^\circ$ ,  $A = 5500$  lb,  $B = 8000$  lb and  $CE = 25'$ . Find the value of angle  $\beta$ , the tension in the cable  $CD$  and the compressive force acting on the pole. (12)

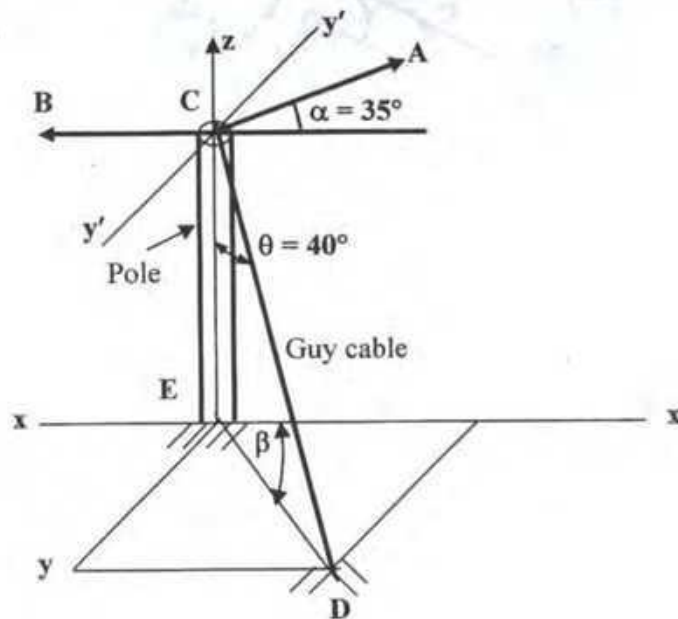

- 8.(a) The layout of a wooden hammer is given below. The weight of the handle is 3.25 lb and the weight of the head is 16.5 lb. Find the radius of gyration of the body with respect to the y axis. (13)

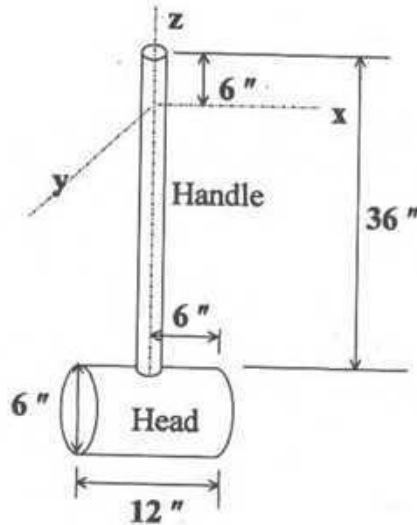

- 8.(b) Three members AB, BC, and BD, each 25 ft. long, form a tripod as shown below. The ends of the timbers on the ground form an equilateral triangle ACD, the sides of which are each 25 ft. long. If the safe compressive load for each timber is 15,000 lb., what safe load  $W$  may be suspended from point B. (12)

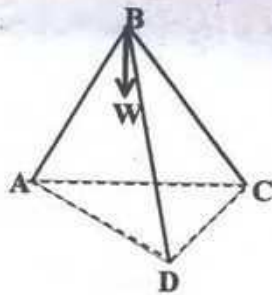

**The University of Asia Pacific**  
**Department of Civil Engineering**  
**Final Examination Spring 2008**  
**Program: B.Sc Engineering (Civil)**

Course # CE 105  
 Full Marks: 150

Course Title: Surveying  
 Time : 3 hrs

*There are two sections in the question paper namely "SECTION A" and "SECTION B". You have to answer from both sections according to the instruction mentioned in each section.*

**SECTION A**

There are **FOUR** questions in this section. Answer any **THREE (25X3 =75)**

1. (a) Explain how will you continue chaining past the following obstacles (6)  
 i) a pond ii) a tall building
- (b) Write short note on Quadrantal Bearing System. (6)
- (c) The following notes refer to three-level cross-section at two sections 60 m apart. The width of the roadbed is 10 m and the side slopes are 1 to 1. (13)

Station	Cross-section		
1.	$\frac{2.5}{7.5}$	$\frac{2.9}{0}$	$\frac{3.8}{10.6}$
2.	$\frac{2.4}{10.5}$	$\frac{2.9}{0}$	$\frac{3.7}{12.9}$

Calculate the volume of cutting between the two stations.

2. (a) Explain with neat diagrams the construction and working principle of an optical square (8)
- (b) For the following traverse, find the length of DE so that A, E and F are in the same straight line: (12)

Side	Length (ft)	W.C.B
AB	250	S 84° 30'E
BC	160	N 75° 18' E
CD	83	N 18° 45' E
DE	-	N 29° 45' E
EF	151	N 64° 10'E

- (c) What are the merits and demerits of 'height of instrument' and 'rise and fall' methods? (5)
3. (a) What are the instruments used in plane table surveying? (6)
- (b) From the contour map shown in figure draw the section along AB. (4)

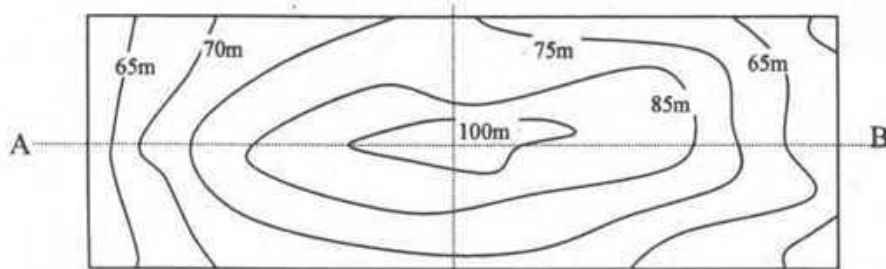

PLAN

- (c) To find the elevation of the top (Q) of a hill, a flag-staff of 2 m height was erected and observations were made from two stations P and R, 60 meters apart. The horizontal angle measured at P between R and the top of the flag-staff was  $60^{\circ}30'$  and that measured at R between the top of the flag staff and P was  $67^{\circ}15'$ . The angle of elevation to the top of the flag-staff P was measured to be  $12^{\circ}15'$  at P. The angle of elevation to the top of the flag staff was measured to be  $10^{\circ}15'$  at R. Staff readings on B.M. when the instrument was at P = 2.965 m and that with the instrument at R = 3.055 m. Calculate the elevation of the top of the hill if that B.M was 455.065 m. (10)
- (d) The magnetic bearing of a line is S  $30^{\circ}15'$  E. Calculate the true bearing if the declination is  $30^{\circ}15'$  West. (5)
4. (a) Discuss any one method of interpolating the contours. (8)  
 (b) Discuss in brief the classification of surveying based on the nature of the field survey. (5)  
 (c) The following consecutive readings were taken with a level. The reduced level of the first point was 208.125 m. Calculate the reduced levels of the points by any method and make a check for it. (12)

Station	B.S.	I.S.	F.S.
1	0.385		
2		1.030	
3		1.925	
4		2.825	
5		3.730	
6	0.625		4.685
7		2.005	
8		3.110	
9			4.485

**Given formula:**

1) Level Section  $A = (b + nh) h$

2) Two-Level Section  $A = \{n (b/2)^2 + m^2 (b+nh)h\} / (m^2 - n^2)$

3) Three-Level Section  $A = \{b (h_1 + h_2) / 4 + h (w_1 + w_2) / 2\}$

$$w_1 = m_1 n / (m_1 - n) (h + b / 2n)$$

$$h_1 = m_1 n / (m_1 - n) (h + b / 2m_1)$$

$$h_2 = m_2 n / (m_2 - n) (h - b / 2m_2)$$

$$4) h_1 = \frac{b \sin \theta_2 \tan \alpha_1}{\sin (\theta_1 + \theta_2)}$$

$$5) h_2 = \frac{b \sin \theta_2 \tan \alpha_2}{\sin (\theta_1 + \theta_2)}$$

**Note:** Here the symbols have their usual meanings.

43

**SECTION B**

There are four questions in this section. Answer any three  
25X3=75

1. a. Define: 4
- i. Point of tangent.
  - ii. Deflection angle.
  - iii. Normal chord.
  - iv. Degree of curvature.
- b. For a simple circular curve, prove that the length of curve,  $l = \frac{100\Delta}{D}$ . 6  
Where,  $\Delta$  is intersection angle and  $D$  is degree of curvature.
- c. A road bend which deflects  $70^\circ$  is to be designed for a maximum speed of 120 km per hour, a maximum centrifugal rate of  $\frac{1}{4}$  and a maximum rate of change of acceleration is  $25 \text{ cm/sec}^3$ , the curve consists of a circular arc combined with two cubic spirals. Calculate (a) the radius of circular arc, (b) the requisite length of transition, (c) the total length of the composite curve, and (d) the chainage of the beginning and end of transition curve and the junction of the transition curves with the circular arc if the chainage of the point of intersection (P.I.) is 42862 meters. 15
2. a. What is Remote Sensing? What are the objectives of remote Sensing? 5
- b. What do you mean by electromagnetic energy in Remote Sensing? Also discuss the major division of spectral wavelength regions with a diagram. 7
- c. Altitude of a star at lower transit is  $22^\circ 20'$ . If the upper transit of the star is the zenith of the place find the declination of the star. Draw rough sketch. 13
3. a. Define and explain: 5
- i. Parallel of Latitude.
  - ii. Nautical Mile.
- b. What do you mean by spherical triangle? Write the important properties of spherical triangle. 7
- c. Explain how you measure the elevation of a point by photographic measurement. Derive necessary mathematical equations. 13
4. a. Show that the transition curve bisects the shift of circular curve. 12
- b. Two tangents intersect at a chainage 69+40, the deflection angle being  $50^\circ 30'$ . Calculate the chainage of i) Point of intersection (P.I.), ii) Point of Curve (P.C.), iii) Point of Tangent (P.T.), iv) length of first and last sub-chord, and v) total number of chord. Curve radius is 20 chains; to connect the two tangents if it is intended to set out the curve by offset from chord. Take peg interval equal to 100 links, length of chain is equal to 20 meters. 13

(Necessary formulae are given in the next page)

44

**Formulae:**

1.  $\alpha = \frac{v^3}{LR}$

2.  $\Delta_c = 1719 \frac{L}{R}$

3. Length of circular curve =  $\frac{\pi R \Delta_c}{180^\circ}$

4. Total tangent length =  $(R + s) \tan \frac{\Delta}{2} + \frac{L}{2}$

5. Tangent length =  $R \tan \frac{\Delta}{2}$

1

**The University of Asia Pacific**  
**Department of Civil Engineering**  
**Final Examination Spring- 2008**  
**Program: B.Sc. Engineering (Civil)**

Course Title: Introduction to Civil &  
Environmental Engineering

Course Code: CE 107

Credit: 2.00

Time: 2 hours

Full Marks: 50

---

There are **TWO** sections in the question paper namely "SECTION A" and "SECTION B". You have to answer from the both sets according to the instruction mentioned on each section.

---

**SECTION A**

Marks: 15

Answer any THREE.

1. What are the general effects of air pollution? What is the difference between point and non point sources of air pollution? Which type is easier to manage? (2+1+2=5)
2. What is the difference between primary and secondary pollutants? Describe five different types of air pollutants along with their sources. What is atmospheric inversion? (1+2+2=5)
3. What is Global warming and how it occurs? Show with sketches how photochemical and sulfurous smog may be developed. (3+2=5)
4. What is acid rain? Show in an idealized diagram some selected aspects of acid rain formation and paths. What measures do you suggest to reduce urban air pollution? (1+2+2=5)

**SECTION B**

Marks: 35

Answer any THREE. All questions carry equal marks.

1. a. Give the names in details of the following codes with their related fields,  
i. AASHTO    ii. ACI    iii. AREA    iv. ASTM    v. BNBC  
b. Write down the organogram of Bangladesh Roads & Highways Department (RHD).  
c. How can you ensure satisfactory quality of brick in the field?  
d. Mention the various merits and demerits of using equipments in the construction project.
2. a. One foreign company proposes the implementation of an underground transportation system under build and transfer basis (BOT) to ease the traffic congestion in Dhaka city. Mention the various steps to be followed by the company during the implementation of the project.  
b. Define contract. Write down the name of various types of contract.  
c. Describe the road transportation network in Bangladesh.

3. The University of Asia Pacific is planning to construct a six storied building under its own supervision. As its fund is limited, the university wants to take loan from a financial institution. Financial institution provides maximum 70% loan of the total construction cost. Estimate the total construction cost and the amount of money to be borrowed as per the PWD schedule (enclosed). The particulars of the building are as follows:

SI No	Particulars	Specification
01	Land Size	50 m x 80 m
02	Road width	20 m
03	Building type	Educational (B-2) (Standard)
04	Allowable Bearing Capacity ( $Q_a$ )	3.5 ksf
05	Floor Level	Six
06	Plinth Area	2000 Square meter
07	Type pf structure	RCC Frame Structure Concrete with Stone Chips, $f_c=22-25$ MPa
08	Ground Floor	Car Parking
09	Lime terracing, RCC cornice and parapet (0.92 m height)	
10	Roof top RCC water tank including beams and supports etc	12,000 Gallons
11	For mosaic work in all rooms including stair, tiles in bathrooms and normal finishing	Tk.950 per square meter
12	Underground water reservoir, distribution line, water pump, pump house, WASA charge	1,00,000 Gallons
13	Boundary wall	RCC frame

4. From the previous data calculate the followings:
- What will be the front set back?
  - What will be the back and side set backs?
  - What is the Floor Area Ratio (FAR) ?
  - Find the maximum number of floor levels that can be constructed.
  - What is the maximum allowable ground coverage (plinth area)?
  - What is the Total Floor Area?
  - What is the required minimum parking space? Is the existing parking space sufficient?
  - If the University authority wants to construct eight storied building, then what will be the ground coverage?

**The University of Asia Pacific**  
**Department of Civil Engineering**  
**Final Examination Spring 2008**  
**Program: B.Sc. Engineering (Civil)**

Course Title: Numerical Analysis &  
Computer Programming

Course Code: CE 205

Credit: 3.00

Time: 3 Hours

Full Marks: 150

There are **EIGHT** questions. Answer any **SIX**.

- 1.(a) Using Regula Falsi method, find the approximate root of the following equation: (10)  
 $5x - x^2 \log_{10} x - 7.9 = 0$ , start the trial with  $x = 1$   
Desired accuracy = 0.0001.

- (b) For the following system of equations: (15)  
 $5u - 3v + 7w = 11$   
 $-6u + v - 4w = 5$   
 $9u - 5v + 2w = 6$

Use Gauss Jordan method to find the inverse of the coefficient matrix and then solve the system.

- 2.(a) For the following data, (15)

Time (sec)	0	10	20	30
Speed (mps)	0.0000	0.0427	0.4772	1.0652

- (i) Find the Gregory Newton Interpolation polynomial for Speed vs Time.  
(ii) Find the speeds at  $t = 23.5$  sec and  $t = 57$  sec.

- (b) Find the inverse cubic root of 30, using Newton's Iterative formula. Desired accuracy = 0.000001. (10)

3. Fit the curve  $y = a x^b$  to the following set of points. (25)

x	2	3	5	8	13	21	34
y	13	20	35	57	76	98	110

Find the value of y corresponding to  $x = 11$ , from the fitted curve.

- 34
4. Experimentally observed values of deflections of a beam are shown in the following figure. (25)

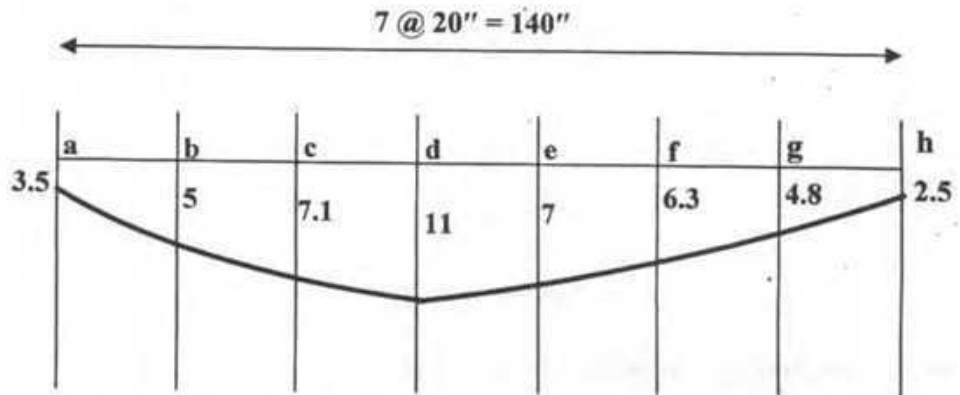

All deflections of the above figure are in ( $\times 10^{-4}$ ) inch.

Calculate :

- The bending moments at points a, d and h.
- The shear forces at points a, f and c.
- The slopes at points b and h.

Given,  $E = 30,000$  ksi,  $I = 1000$  in<sup>4</sup>. The bending moment at any section of a beam is given by the equation of  $M = -EI D^2 y$ ; Shear Force is given by  $SF = -EI D^3 y$  and Slope is given by  $\theta = Dy$ .

- 5.(a) Evaluate the solution of  $y' = dy/dx = 0.4(1+x^2)y^2$ , using Euler method for  $x = 0.2, 0.3$  and  $0.5$ , where  $y(x=0) = 2$  (13)

- (b) Using Newton Raphson method, find the real root of the following equation:  $f(x) = e^x - \cos(\pi x/2)$ , desired accuracy = 0.00001. Start trial with  $x = 0.4$ . (12)

or Suppose, there are three matrices as follows: (25)

$$A = \begin{bmatrix} 2 & 3 & 5 \\ 8 & 4 & 1 \\ 9 & 6 & 4 \end{bmatrix} \quad B = \begin{bmatrix} 1 & 6 & 3 \\ 2 & 8 & 5 \\ 3 & 7 & 5 \end{bmatrix} \quad C = \begin{bmatrix} 2 & 4 & 9 \\ 3 & 1 & 5 \\ 8 & 3 & 6 \end{bmatrix}$$

Write a C++ program to find  $[(A \times B) - C]$

- 6.(a) Approximate the following definite integrals, using Gaussian Quadrature. (13)

(i)  $I = \int_0^3 (x^3 - 5x) \cos x dx$  (for  $n = 2$ )

(ii)  $I = \int_{-1}^1 (x^2 - 3) \sin^2 x dx$  (for  $n = 3$ )

(b) Evaluate the following integral using the Simpson's rule:

(12)

$$I = \int_2^{4.4} 10 \log_e x dx, \text{ consider eight equal subdivisions and compare with the exact value.}$$

7.(a) A  $W = 200^N$  block rests on a rough surface, whose static frictional coefficient,  $f = 0.3$ . A force  $Q$  acts on the body as shown in the figure. The value of  $Q$ , which will cause the block to be in impending motion toward the left, is to be calculated through a C++ program. (13)

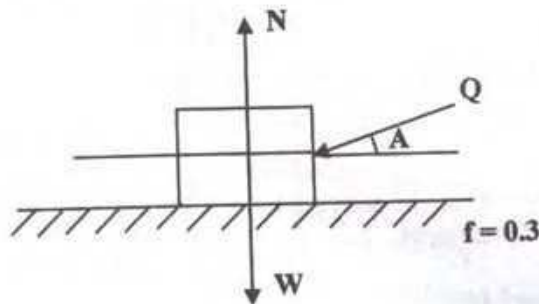

```
# include <iostream.h>
# include <math.h>
void main( )
{
    double W, N, f, F, Q, A, A1, A2 ;
    W = 250 ;
    f = 0.3;
    cin >> A ;
    if (A == 0)
    {
        N = W ;
        F = f * N ;
        Q = F ;
        cout << "Q =" << Q << endl ;
    }
    else if (A > 0 && A < 90)
    {
        A1 = sin (A * (22.0 / 7) / 180) ;
        cout << "A1 =" << A1 << endl ;
        A2 = cos (A * (22.0 / 7) / 180) ;
        cout << "A2 =" << A2 << endl ;

        Q = (f * W) / (A2 - f * A1) ;

        cout << "Q =" << Q << endl ;
    }
    else
        cout << "No movement will occur towards the left" << endl ;
}
```

Write down the output of the above program, when

- (i)  $A = 20^\circ$
- (ii)  $A = 90^\circ$
- (iii)  $A = 0^\circ$
- (iv)  $A = 75^\circ$

Note: While using calculator change the degree mode to radian mode.

- (b) Write a C++ program to calculate the grades of ten examinees using **If** statement. Follow the instructions given below: (12)

Marks < 30, Grade: C  
 $30 \leq$  Marks < 40, Grade: B  
 $40 \leq$  Marks  $\leq$  50, Grade: A

- 8.(a) To calculate the sum of the series  $1 + 4 + 7 + 10 + 13 + \dots + n$  terms, write a C++ program using **If** statement (10)

- (b) A triangular area having a base of 5 m and height of 3 m has been excavated from a  $7\text{m} \times 3\text{m}$  rectangular field. Again the shaded area is equal to the area of a circle. Write a C++ program to calculate the shaded area and the radius of the circle. Take  $\pi = 22.0 / 7$ . Use **r** for radius of circle, **TA** for triangular area, **RA** for rectangular area, **SA** for shaded area and **CA** for circular area. (15)

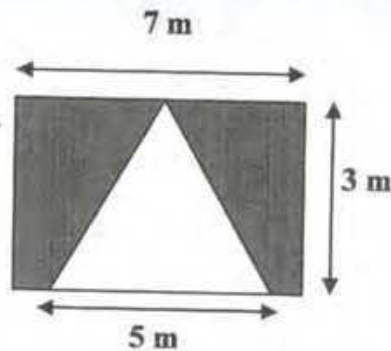

ANNEXURE

**Table:** Weighing coefficients  $w_n$  and associated points  $x_n$  for the Gaussian Quadrature Formula

$n$	$w_n$	$x_n$
2	8/9	0
	5/9	$\pm 0.7746$
3	0.6521	$\pm 0.34$
	0.3479	$\pm 0.8611$
4	0.5689	0
	0.4786	$\pm 0.5385$
	0.2369	$\pm 0.9062$
5	0.4679	$\pm 0.2386$
	0.3608	$\pm 0.6612$
	0.1713	$\pm 0.9325$

**Mathematical Models for Difference Formula**

**A. Backward Difference ( $\nabla$ )**

	$y_n$	$y_{n-1}$	$y_{n-2}$	$y_{n-3}$	$y_{n-4}$
$hD$	1	-1			
$h^2D^2$	1	-2	1		
$h^3D^3$	1	-3	3	-1	
$h^4D^4$	1	-4	6	-4	1

**B. Forward Difference ( $\Delta$ )**

	$y_n$	$y_{n+1}$	$y_{n+2}$	$y_{n+3}$	$y_{n+4}$
$hD$	-1	1			
$h^2D^2$	1	-2	1		
$h^3D^3$	-1	3	-3	1	
$h^4D^4$	1	-4	6	-4	1

**C. Central Difference ( $\delta$ )**

	$y_{n-2}$	$y_{n-1}$	$y_n$	$y_{n+1}$	$y_{n+2}$
$2hD$		-1	0	1	
$h^2D^2$		1	-2	1	
$2h^3D^3$	-1	2	0	-2	1
$h^4D^4$	1	-4	6	-4	1

**The University of Asia Pacific**  
**Department of Civil Engineering**  
**Final Examination Spring 2008**  
**Program: B. Sc Engineering (Civil)**

Course Title: Mechanics of Solids II    Course Code: CE 213  
 Time : 3.00 Hours

Credit: 3.00  
 Full Marks: 100 (= 10 × 10)

[Answer any 10 (ten) of the following 14 questions]

1. In the figure shown below, calculate the maximum permissible value of  $T$  required to meet the following conditions:  $\tau_{st} \leq 12 \text{ ksi}$ ,  $\tau_{al} \leq 8 \text{ ksi}$  and the torsional rotation at  $C$  is limited to  $6^\circ$  [Given:  $G_{al} = 4000 \text{ ksi}$ ,  $G_{st} = 12000 \text{ ksi}$ ].

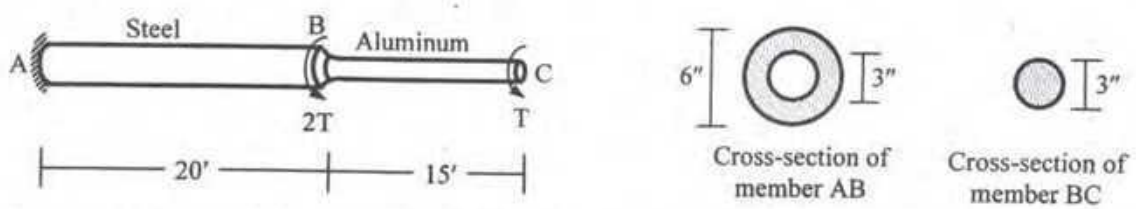

2. Calculate the torsional shear stress at  $A$  and the torsional rotation at  $B$  for the circular rod (of non-uniform diameter) shown below (Neglect stress concentration) [Given:  $G = 12000 \text{ ksi}$ ].

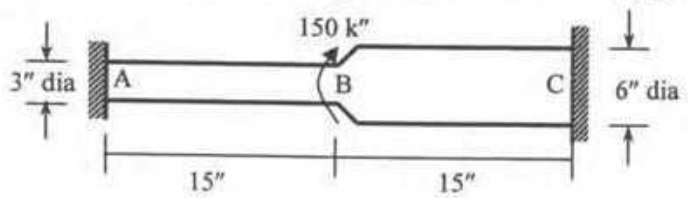

3. A load  $P$  is supported by two steel springs ( $A$  and  $B$ ) arranged in series as shown below. Determine the maximum shearing stress in each spring if the total deflection is  $3''$   
 [Given: Spring  $A$ :- coil diameter =  $1''$ , number of coils =  $20$ , average spring diameter of spring  $A = 6''$ .  
 Spring  $B$ :- coil diameter =  $0.5''$ , number of coils =  $15$ , average spring diameter of spring  $B = 5''$   
 Shear Modulus,  $G = 12000 \text{ ksi}$ ].

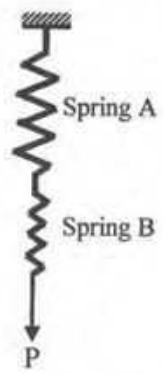

4. The maximum shearing stress at point  $A$  in a beam as shown below is  $120 \text{ psi}$ . Determine the magnitude of the force  $P$ . Assume the beam to be weightless.

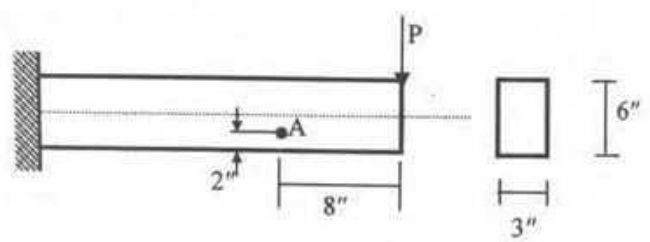

- 26
5. A cast iron block is loaded as shown in the following figure. Neglecting the weight of the block, determine the normal stresses acting at section  $abcd$  and locate the line of zero stress.

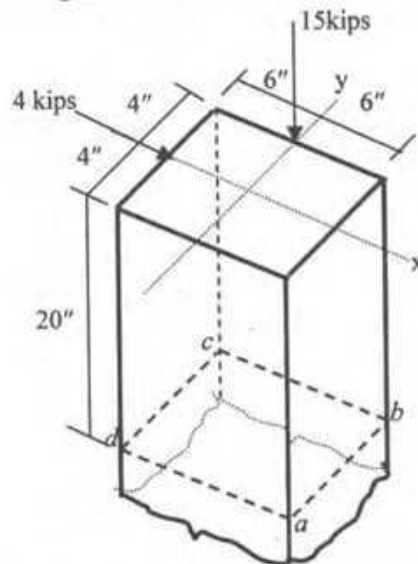

6. Use the Mohr's circle to calculate the normal stress and shear stress on the plane  $a-a'$  shown in the element below. Also calculate the required yield strength  $f_y$  to avoid yielding of the material using the yield criteria suggested by *St. Venant* [Given: Poisson's ratio = 0.25].

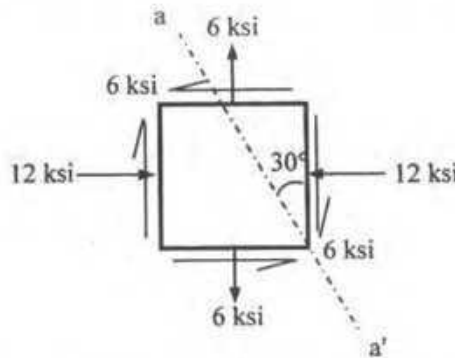

7. For the beam shown below, use the Singularity Functions to calculate the deflection at C and rotations at the left and right of C [ $EI = \text{constant}$ ].

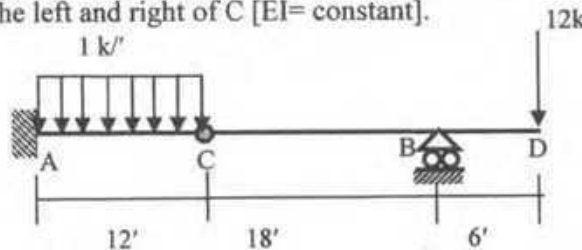

C is an Internal Hinge

8. Answer Question 7 using the Moment-Area Theorems.
9. For the beam shown below, use the Conjugate Beam Method to calculate the deflection at B and rotations at the left and right of B [ $EI = \text{constant}$ ].

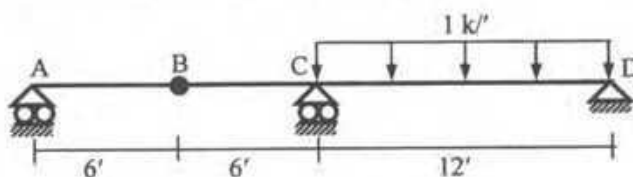

B is an Internal Hinge

10. Draw the shear force and bending moment diagram of the beam shown below [Given:  $EI = \text{constant}$ ].

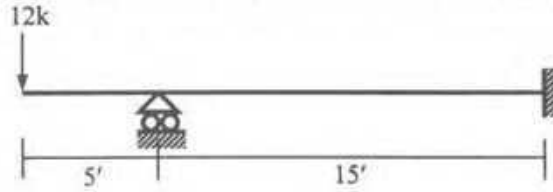

11. For the beam shown below

- (i) Write down the expressions for loading function  $w(x)$  using singularity functions.
- (ii) Write down the corresponding boundary conditions.
- (iii) Determine whether the beams are statically determinate or indeterminate.
- (iv) Draw the qualitative deflected shapes of the beams under the given loads.

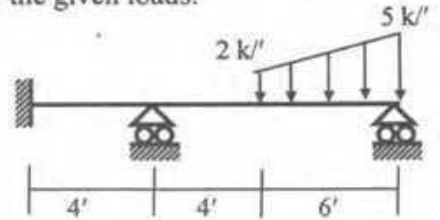
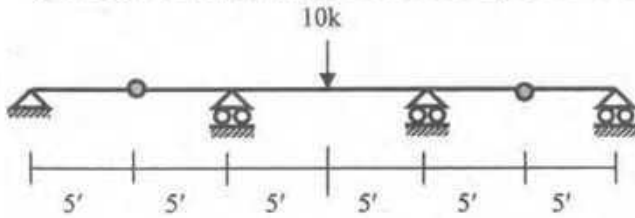

12. Use the AISC-ASD criteria to calculate the allowable value of  $F$  to avoid buckling of any member of the truss shown below [Given: Member cross section is as shown, with  $E = 29000$  ksi,  $f_y = 40$  ksi].

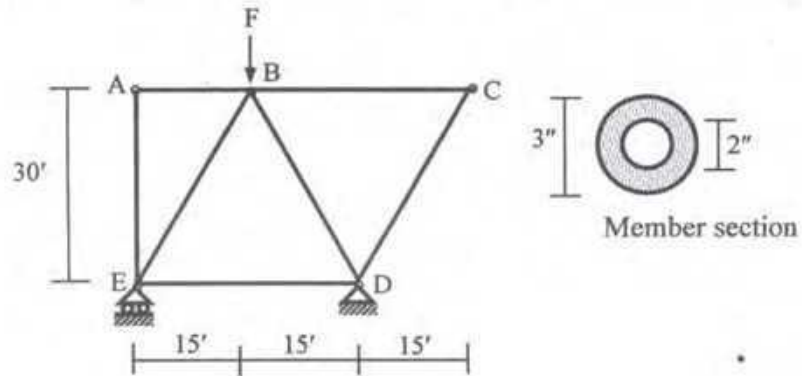

13. The beam ACB shown below is subjected to compressive loads ( $P$ ) applied at both ends at an eccentricity of ' $e$ '. If  $P = 100$  kips, calculate the value of ' $e$ ' in order to avoid tensile stress anywhere in the beam [Given: Member cross section is as shown, with  $E = 30000$  ksi].

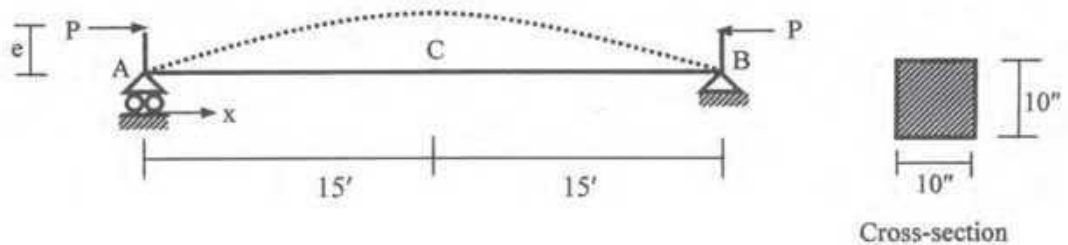

14. Calculate the Eulers load for columns AB and CD in the frame shown below [Given:  $E=2000$  ksi,  $EI = \text{constant}$ ].

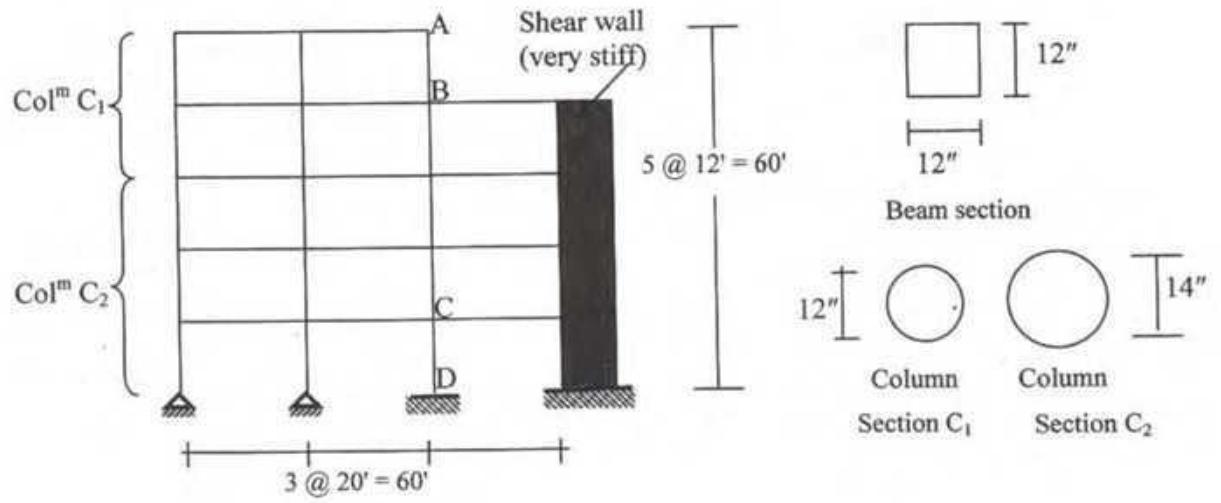

## List of Useful Formulae for CE 213

\* Torsional Rotation  $\phi_B - \phi_A = \int (T/J_{eq}G) dx$ , and  $= (TL/J_{eq}G)$ , if  $T$ ,  $J_{eq}$  and  $G$  are constants

Section	Torsional Shear Stress	$J_{eq}$
Circular	$\tau = Tc/J$	$\pi d^4/32$
Thin-walled	$\tau = T/(2A t)$	$4A^2/(Jds/t)$
Rectangular	$\tau = T/(\alpha b t^2)$	$\beta b t^3$

b/t	1.0	1.5	2.0	3.0	6.0	10.0	$\alpha$
$\alpha$	0.208	0.231	0.246	0.267	0.299	0.312	0.333
$\beta$	0.141	0.196	0.229	0.263	0.299	0.312	0.333

\* Biaxial Bending Stress:  $\sigma_x(z, y) = M_x y/I_x + M_y z/I_y$

\* Combined Axial Stress and Biaxial Bending Stress:  $\sigma_x(x, y) = -P/A - M_x y/I_x - M_y z/I_y$

\* Corner points of the kern of a Rectangular Area are  $(b/6, 0)$ ,  $(0, h/6)$ ,  $(-b/6, 0)$ ,  $(0, -h/6)$

\* Maximum shear stress on a Helical spring:  $\tau_{max} = \tau_{direct} + \tau_{torsion} = P/A + Tr/J = P/A (1 + 2R/r)$

\* Stiffness of a Helical spring is  $k = Gd^4/(64R^3N)$

\*  $\sigma_{xx}' = (\sigma_{xx} + \sigma_{yy})/2 + \{(\sigma_{xx} - \sigma_{yy})/2\} \cos 2\theta + (\tau_{xy}) \sin 2\theta = (\sigma_{xx} + \sigma_{yy})/2 + \sqrt{\{[(\sigma_{xx} - \sigma_{yy})/2]^2 + (\tau_{xy})^2\}} \cos (2\theta - \alpha)$   
 $\tau_{xy}' = -\{(\sigma_{xx} - \sigma_{yy})/2\} \sin 2\theta + (\tau_{xy}) \cos 2\theta = \tau_{xy}' = -\sqrt{\{[(\sigma_{xx} - \sigma_{yy})/2]^2 + (\tau_{xy})^2\}} \sin (2\theta - \alpha)$

where  $\tan \alpha = 2 \tau_{xy}/(\sigma_{xx} - \sigma_{yy})$

\*  $\sigma_{xx(max)} = (\sigma_{xx} + \sigma_{yy})/2 + \sqrt{\{[(\sigma_{xx} - \sigma_{yy})/2]^2 + (\tau_{xy})^2\}}$ ; when  $\theta = \alpha/2, \alpha/2 + 180^\circ$

$\sigma_{xx(min)} = (\sigma_{xx} + \sigma_{yy})/2 - \sqrt{\{[(\sigma_{xx} - \sigma_{yy})/2]^2 + (\tau_{xy})^2\}}$ ; when  $\theta = \alpha/2 \pm 90^\circ$

\*  $\tau_{xy(max)} = \sqrt{\{[(\sigma_{xx} - \sigma_{yy})/2]^2 + (\tau_{xy})^2\}}$ ; when  $\theta = \alpha/2 - 45^\circ, \alpha/2 + 135^\circ$

$\tau_{xy(min)} = -\sqrt{\{[(\sigma_{xx} - \sigma_{yy})/2]^2 + (\tau_{xy})^2\}}$ ; when  $\theta = \alpha/2 + 45^\circ, \alpha/2 - 135^\circ$

\* Mohr's Circle: Center  $(a, 0) = [(\sigma_{xx} + \sigma_{yy})/2, 0]$  and radius  $R = \sqrt{\{[(\sigma_{xx} - \sigma_{yy})/2]^2 + (\tau_{xy})^2\}}$

\* Maximum Normal Stress Theory (Rankine):  $|\sigma_1| \geq Y$ , or  $|\sigma_2| \geq Y$ .

\* Maximum Normal Strain Theory (St. Venant):  $|\sigma_1 - \nu\sigma_2| \geq Y$ , or  $|\sigma_2 - \nu\sigma_1| \geq Y$ .

\* Maximum Shear Stress Theory (Tresca):  $|\sigma_1 - \sigma_2| \geq Y$ ,  $|\sigma_1| \geq Y$ , or  $|\sigma_2| \geq Y$

\* Maximum Distortion-Energy Theory (Von Mises):  $\sigma_1^2 + \sigma_2^2 - \sigma_1\sigma_2 = Y^2$

\*  $M(x) = EI \kappa \cong EI d^2v/dx^2$

\*  $w(x) \cong EI d^4v/dx^4$ ,  $V(x) = \int w(x) dx \cong EI d^3v/dx^3$ ,  $M(x) = \int V(x) dx \cong EI d^2v/dx^2$

$S(x) = \int M(x) dx \cong EI dv/dx \cong EI \theta(x)$ ,  $D(x) = \int S(x) dx \cong EI v(x)$

\* Singularity Functions for Common Loadings

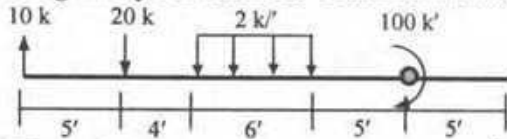

$$w(x) = 10\langle x-0 \rangle^{-1} - 20\langle x-5 \rangle^{-1} - 2\langle x-5 \rangle^0 + 2\langle x-15 \rangle^0 + 100\langle x-20 \rangle^{-2} + C_0\langle x-20 \rangle^{-3}$$

\* First Moment-Area Theorem:  $\theta_B - \theta_A = \int (M/EI) dx$

\* Second Moment-Area Theorem:  $(x_B - x_A) \theta_B - v_B + v_A = \int x (M/EI) dx$

\* Conjugate Beam Method

Original Beam	Free End	Fixed End	Hinge/Roller End	Internal Support	Internal Hinge
Conjugate Beam	Fixed End	Free End	Hinge/Roller End	Internal Hinge	Internal Support

\* Euler Buckling Load:  $P_{cr} = \pi^2 EI_{min}/(kL)^2$

\* Effect of Initial Imperfection:  $v(x) = v_0/[1 - P/P_{cr}] \sin(\pi x/L) \Rightarrow v(L/2) = v_0/[1 - P/P_{cr}]$

\* Effect of Load Eccentricity:  $\lambda^2 = P/EI \Rightarrow v(L/2) = e [\sec \lambda L/2 - 1] = e [\sec \{(\pi/2)\sqrt{(P/P_{cr})}\} - 1]$

\* Effect of Material Nonlinearity:  $P_{cr} = \pi^2 E_t/L^2 \Rightarrow \sigma_{cr} = \pi^2 E_t/\eta^2$

\* Eccentric Loading with Elasto-plastic Material:

$v(L/2) = e [\sec \{(\pi/2)\sqrt{(P/P_{cr})}\} - 1]$  for the elastic range; and  $v(L/2) = M_p/P - e$ , for the plastic range

\*  $k = 1.0$  for Hinge-Hinged Beam,  $0.7$  for Hinge-Fixed Beam,  $0.5$  for Fixed-Fixed Beam,  $2.0$  for Cantilever Beam

In general,  $k$  is obtained from  $\psi_A$  and  $\psi_B$  for braced and unbraced frames

\* AISC-ASD Method,  $\eta = L_e/r_{min}$ , and  $\eta_c = \pi\sqrt{(2E/f_y)}$

If  $\eta \leq \eta_c$ ,  $\sigma_{all} = f_y [1 - 0.5 (\eta/\eta_c)^2]/FS$ , where  $FS = [5/3 + 3/8 (\eta/\eta_c) - 1/8 (\eta/\eta_c)^3]$

If  $\eta > \eta_c$ ,  $\sigma_{all} = (\pi^2 E/\eta^2)/FS$ , where  $FS = \text{Factor of safety} = 23/12 = 1.92$

\* Moment magnification factor for a Simply Supported Beam

for concentrated load at midspan of  $= [\tan(\lambda L/2)/(\lambda L/2)]$ , subjected to end moments only  $= [\sec(\lambda L/2)]$

under UDL  $= 2 [\sec(\lambda L/2) - 1]/(\lambda L/2)^2$ , according to AISC code  $= 1/(1 - P/P_{cr})$

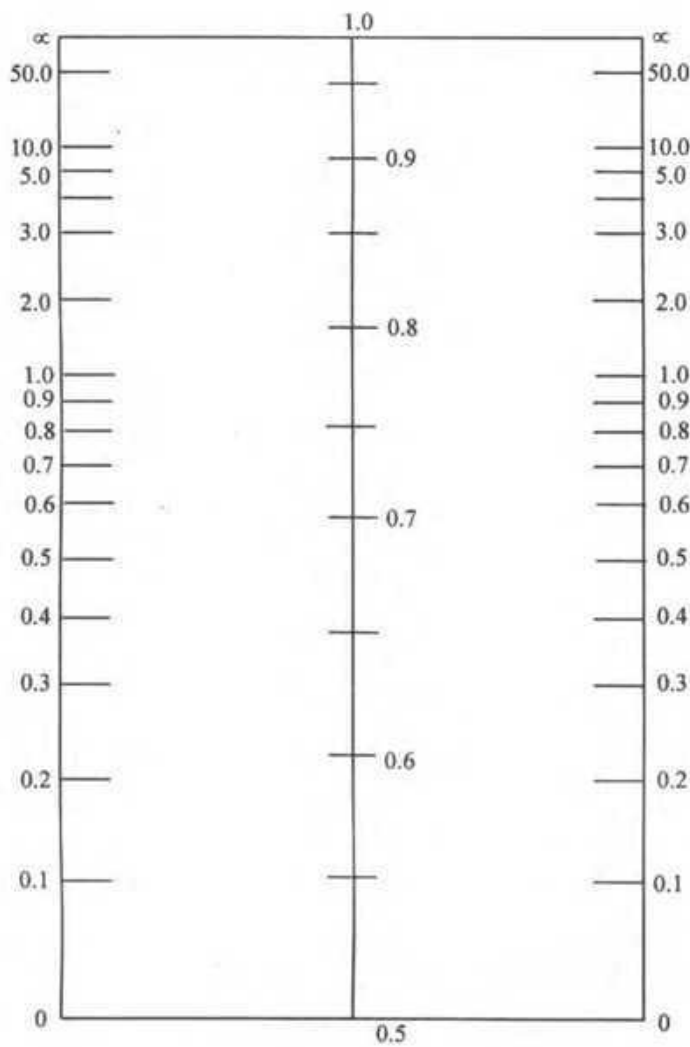

Braced Frames

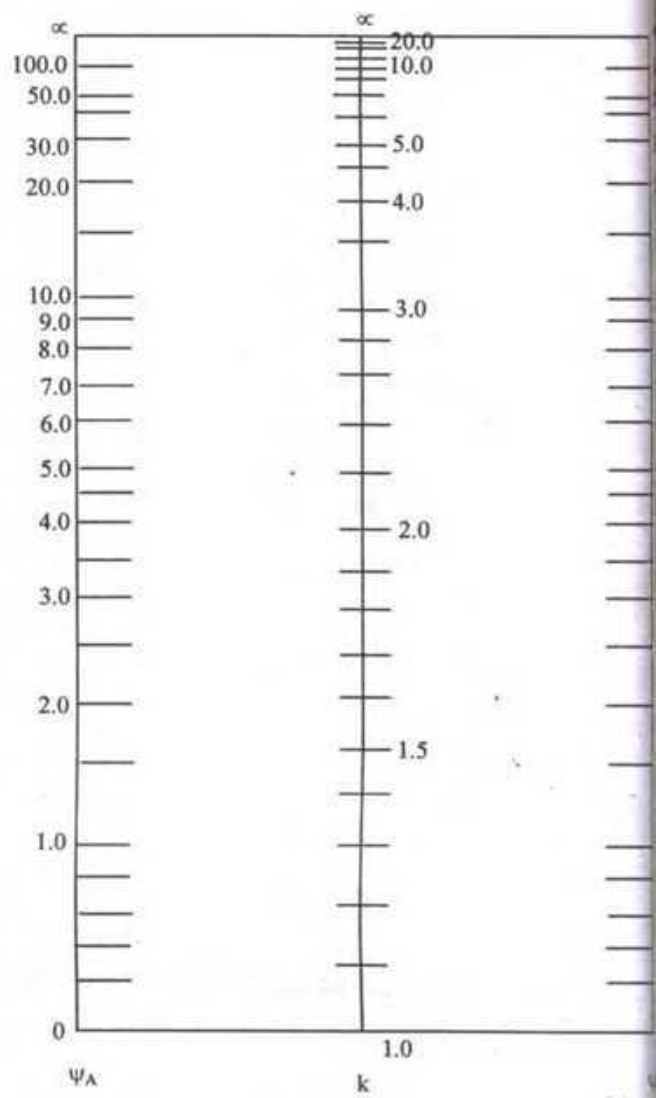

Unbraced Frames

**Alignment Charts for Effective Length Factors  $k$**

$\psi$  = Ratio of  $\sum EI/L$  of compression members to  $\sum EI/L$  of flexural members in a plane at one end of a compression member.

$k$  = Effective length factor.

**The University of Asia Pacific**  
**Department of Civil Engineering**  
**Final Examination Spring 2008**  
**Program: B.Sc. Engineering Civil**

Course Title: Fluid Mechanics  
Time : 3.0 hours

Course No : CE 221  
Full Marks : 150

Credit: 3.00

---

Answer any 6 (SIX) questions. Figures in the right margin indicate full marks.

---

- 1 a. Differentiate between, (i) Lagrangian Method and Eulerian Method 6  
(ii) Ideal and Real Fluid  
(iii) Uniform and Non-Uniform Flow
- b. A space of 5.0 cm between two large plane surfaces is filled with glycerine as shown in Figure 1. Determine the force (F) required to drag vertically a very thin plate  $0.80 \text{ m}^2$  in area between the plane surfaces at a constant speed of 1 m/s, if the plate is at a distance of 2.25 cm from one of the surfaces. Take dynamic viscosity  $0.05 \text{ N-s/m}^2$  and weight of the plate 6 N. 9

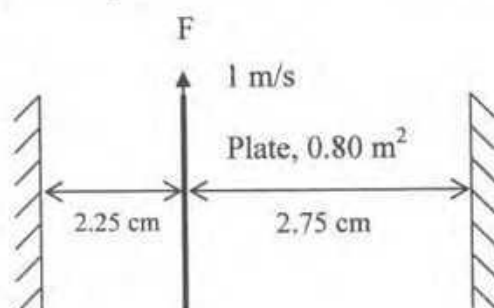

Figure 1

- c. Estimate the height to which water column at  $20^\circ\text{C}$  will rise in a capillary tube 4 mm diameter. Assume Surface Tension  $\sigma = 0.0735 \text{ N/m}$  and  $\theta = 30^\circ$ . 5
- d. By how much does the pressure in a cylindrical jet of water 6 mm in diameter exceed the pressure of the surrounding atmosphere if the surface tension of water is  $0.075 \text{ N/m}$ . 5
- 2 a. Define gauge pressure and vacuum pressure. 4
- b. What is a piezometer? Can a piezometer be used for measuring pressure in the pipe in which a gas is flowing? 4
- c. State Pascal's Law. 4

- d. Compute "y" in Figure 2 if the pressure differences between points A and B is  $150.00 \text{ kN/m}^2$ . ( $P_A > P_B$ )

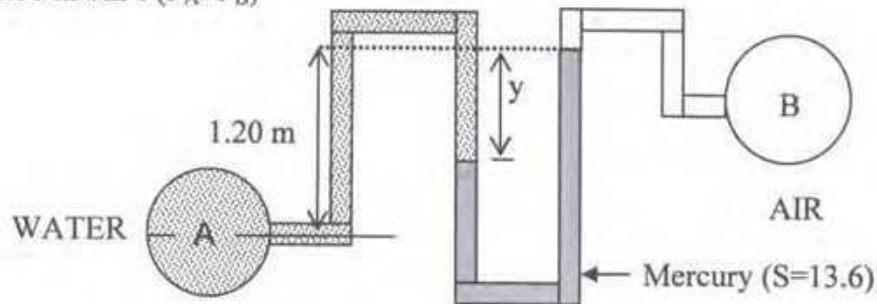

Figure 2

- e. Calculate  $h_1$ ,  $P_A$  and  $h_2$  from Figure 3.

6

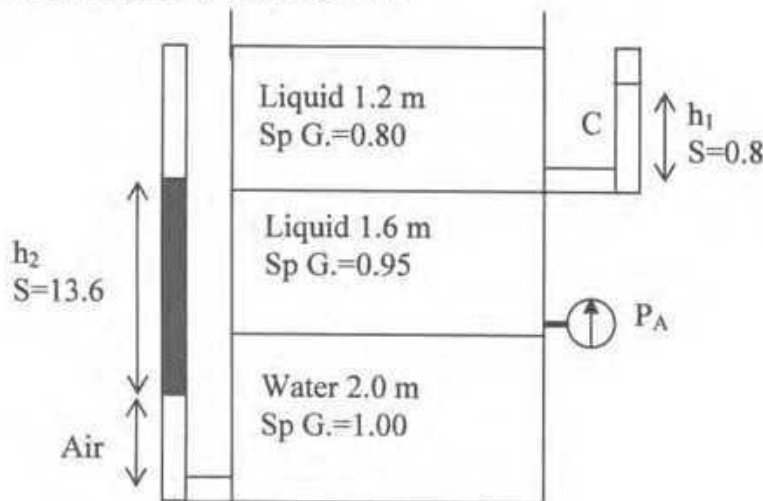

Figure 3

- 3 a. State Bernoulli equation and explain each term with neat figure. Mention clearly the assumptions made in the equation. 6
- b. What do you understand by the term 'centre of pressure'? 6
- c. Water enters in a  $120^\circ$  horizontal reducing pipe with a velocity of  $5 \text{ m/sec}$  and a pressure of  $80 \text{ kN/m}^2$  as shown in Figure 4. If the diameters at the entrance and exit sections are  $25 \text{ cm}$  and  $15 \text{ cm}$  respectively, calculate the components of the reaction e.g.  $R_x$  and  $R_y$  acting on the pipe. 13

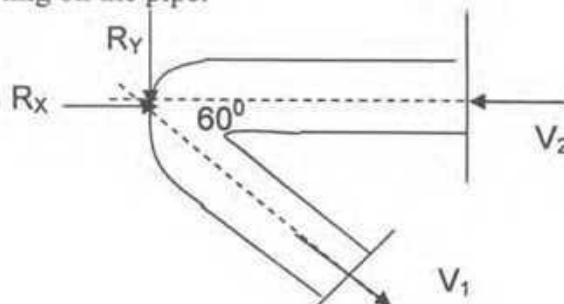

Figure 4

- 4 a. Calculate the total pressure and the depth of the center of pressure on the inclined gate AB shown in Figure 5, the width of the gate perpendicular to the plane of paper is one metre.

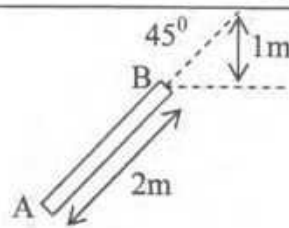

Figure 5

- b. Determine the horizontal and vertical forces acting on the curve surface CD on the cylinder in Figure 6.

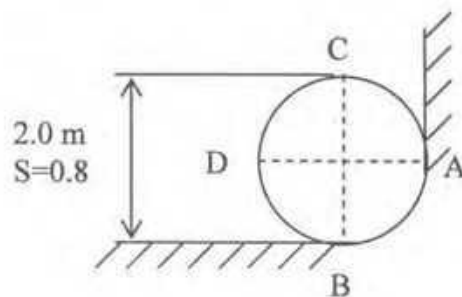

Figure 6

- c. Determine the horizontal and vertical forces acting on the curve surface DB on the cylinder in Figure 6.
- d. What is the net vertical force acting on the cylinder shown in Figure 6, if it weighs 24.5 kN. Neglect friction.
- 5 a. Define, (i) coefficient of contraction  
(ii) coefficient of velocity, and  
(iii) coefficient of discharge
- b. A circular orifice, 3.5 cm diameter, is made in the vertical wall of a tank. The jet falls vertically through 0.5 m while moving horizontally through a distance of 1.5 m. Calculate the coefficient of velocity if the head causing flow is 1.2 meters. If the discharge is  $1.80 \times 10^{-3} \text{ m}^3/\text{s}$ , Calculate  $C_c$  and  $C_d$ .
- c. Water is discharging through an external mouthpiece of  $30 \text{ cm}^2$  area, under a head of 4.0 m. Find the discharge through the mouthpiece. Take  $C_c=0.62$ .

- d. Two sides of a cylinder fitted with a piston are connected to the inlet and the throat of a horizontal venturimeter as shown in Figure 7. If the diameter at the inlet and the throat are 10 cm and 6 cm respectively and the velocity of water in the pipe is 5 m/s, calculate the force on the piston. The diameter of the piston is 2 cm. Ignore losses. 9

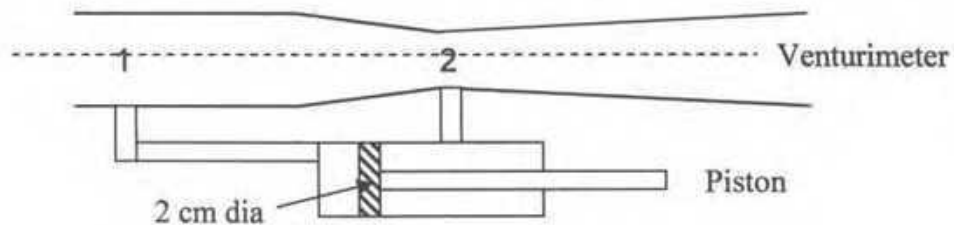

Figure 7

- 6 a. What is the difference between a weir and an orifice? How are the weirs classified? 6
- b. A rectangular channel 1.50 m wide has a rectangular weir at the end. If the length of the weir is 1.20 m, and its sill is 0.2 m from the bottom, find the discharge when the measured head over the crest is 0.30 m. Take  $C_d=0.62$ . 7
- c. Show that the flow over a triangular notch can be expressed as,  $Q = \frac{8}{15} C_d \sqrt{2g} \tan \frac{\theta}{2} H^{\frac{5}{2}}$  8
- d. A sluice gate spans a channel 10 m wide. If the upstream depth is 3 m and the gate is raised by 0.3 m, determine the discharge. Take  $C_d=0.58$ . 4
- 7 a. What is Dimensional analysis? What are the different applications of the principles of Dimensional homogeneity in fluid mechanics? 6
- b. Check whether the following equations are dimensionally homogenous: 9
- a.  $Q = C_d a \sqrt{2gH}$       b.  $V = C \sqrt{RS}$       c.  $h_f = f \frac{L}{D} \frac{V^2}{2g}$
- c. Two reservoirs A & B shown in Figure 8 are connected by a pipe line consisting of two pipes, one of 15 cm diameter and length 6 m and the other of diameter 30 cm and 16 m length. If the difference of water levels in the two reservoirs is 6 m, calculate the discharge through the pipe. Take  $f=0.04$  10

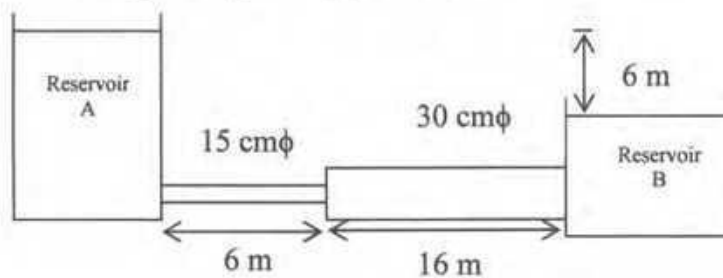

Figure 8

8 a. What do you understand by 'minor losses' in pipes? Mention the places with neat sketches where minor losses may occur. 6

b. A pipe of 1 m diameter connects two reservoirs having a difference of level of 6 m 12  
as shown in Figure 9. The total length of the pipe is 800 m and rises to a maximum height of 3 m above the level of water in the higher reservoir at a distance of 200 m from the entrance. Find the discharge in the pipe and the pressure at the highest point. Take  $f = 0.04$ , and neglect minor losses.



Figure 9

c. Water is flowing through a pipe. The energy grade line is shown in Figure 10. 7  
Calculate flow of water through the pipe. Take  $f = 0.04$ .

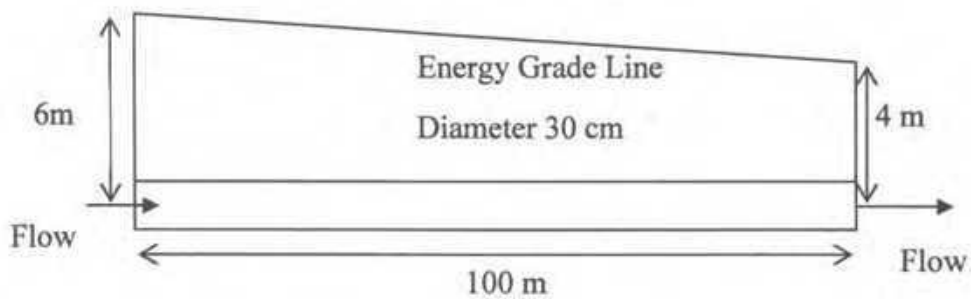

Figure 10

**The University of Asia Pacific**  
**Department of Civil Engineering**  
**Final Examination Spring 2008**  
**Program: B.Sc Engineering (Civil)**

Course Title : Structural Engineering II  
 Time: 3.00 Hours

Course Code : CE 313  
 Full Marks: 160

*There are Ten questions. Answer any Eight (20X8=160)*

1. Use the method of consistent deformation to analyze and draw bending moment diagram of the entire frame shown below. Consider only bending deformations. E and I are constant.

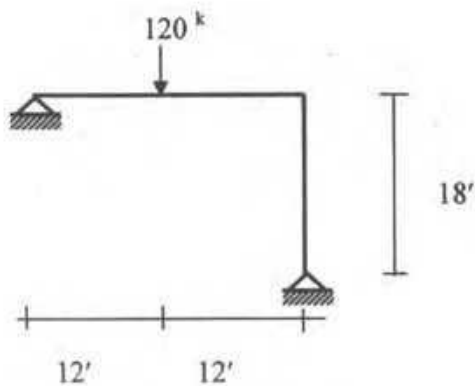

2. Calculate the earthquake force for an interior frame AB of the structure shown below. The structure is to be used as a hospital building located at Sylhet (zone 3). The soil is medium stiff clay. The building system shall be special moment resisting frame of concrete. The slab is 6 inch thick. Partition and floor finish load have been estimated to be 50 psf. Assume any reasonable value for any data not given above. (A relevant page from BNBC is attached)

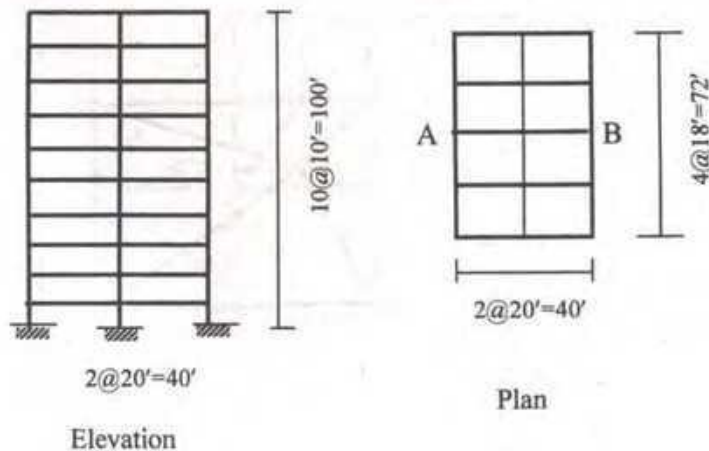

3. Compute the bar forces of the truss shown in figure below due to the support movements  
 Support at a, 0.24 in. down  
 Cross sectional areas in square inches are shown in parentheses and  
 $E = 30 \times 10^3 \text{ kips/in}^2$

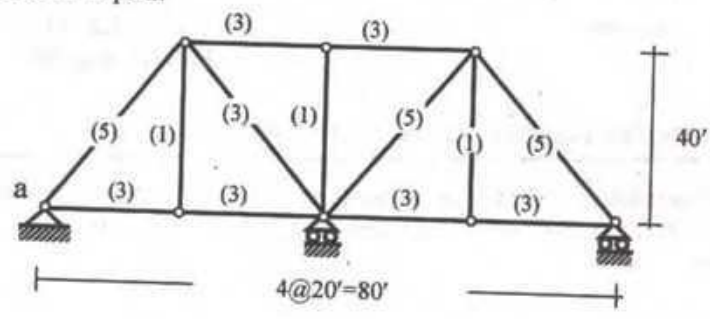

4. Draw bending moment and shear force diagram for the frame shown below. Use approximate method by making necessary assumptions.

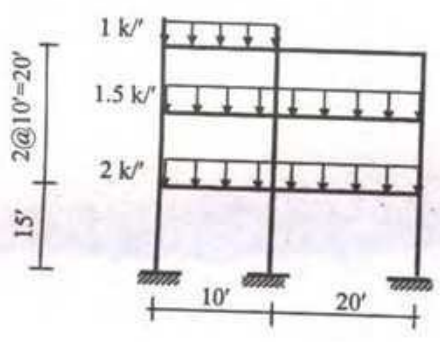

5. Calculate the support reactions and member forces of the space truss loaded as shown below.

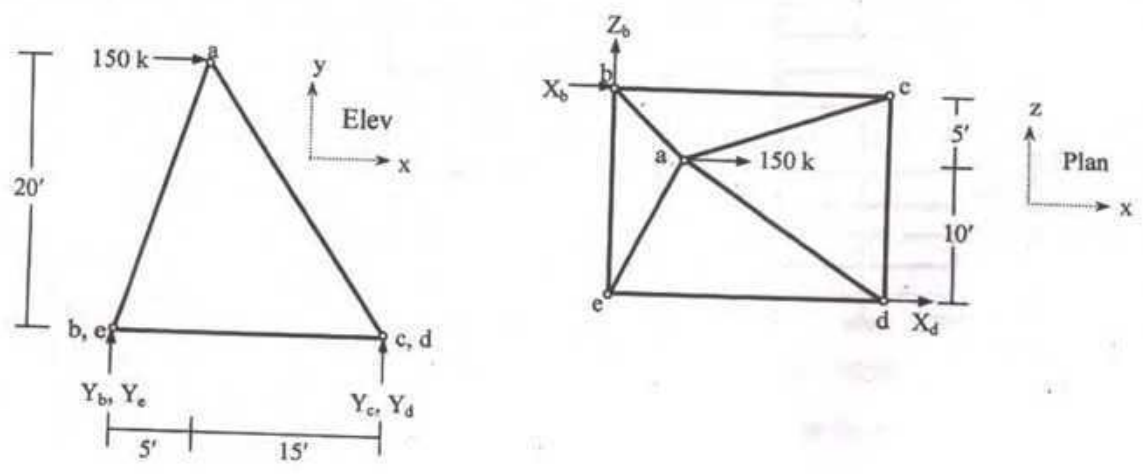

6. For the bridge portal shown in figure below
- Compute bar forces for the indicated members
  - Draw the approximate bending moment diagrams of columns AB and CD

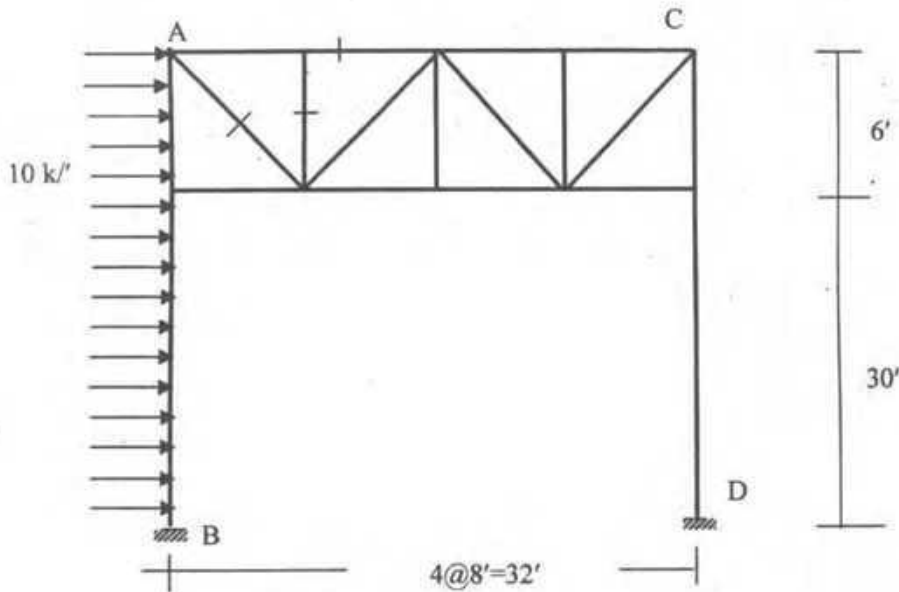

7. Compute the relative deflections of joints b and D along the line joining them due to the following causes:
- The loads shown,  $E = 30 \times 10^3$  kips/in<sup>2</sup>
  - An increase in temperature  $40^\circ$  C in the top chord, a decrease of  $10^\circ$  in the bottom chord.

Cross sectional areas in square inches are shown in parentheses and  $\alpha_t = 1/75,000$  per  $^\circ$ C

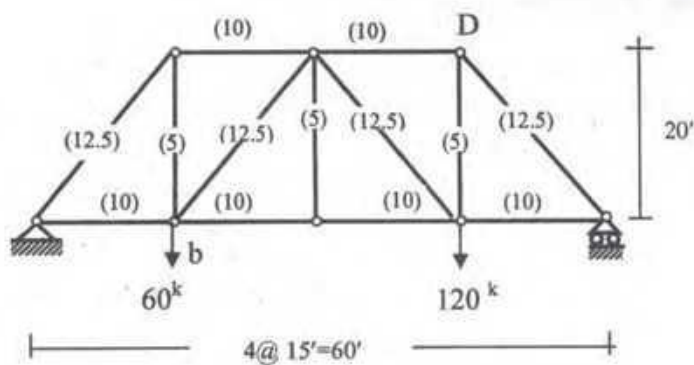

8. Use the Cantilever method to analyze the frame shown in the figure below and draw bending moment diagram for the entire frame.

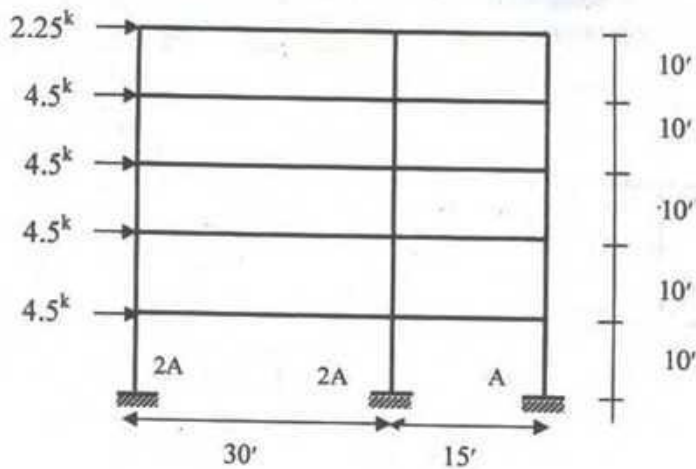

9. (a) Use the Portal Method to draw the axial force, shear force and bending moment diagrams of the structures loaded as shown below

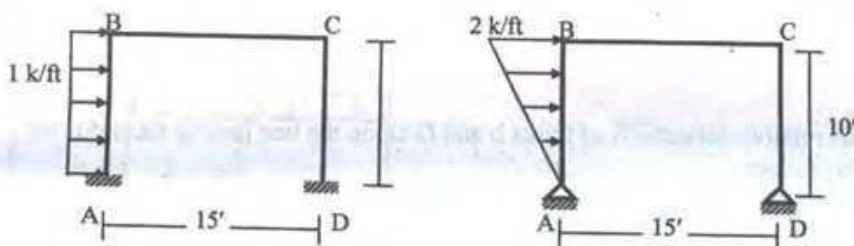

- (b) Mention the name of any three **Building Codes** used in the world.

10. Compute the vertical deflection at 'a' of the beam due to the load shown.  
 $E = 30 \times 10^3 \text{ kips/in}^2$ ,  $I = 200 \text{ in}^4$

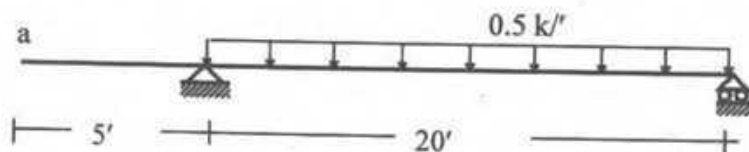

2.5.6 **Equivalent Static Force Method**

This method may be used for calculation of seismic lateral forces for all structures specified in Sec 2.5.5.1(a)

**2.5.6.1 Design Base Shear :** The total design base shear in a given direction shall be determined from the following relation :

$$V = \frac{ZIC}{R}W \quad (2.5.1)$$

where,  $Z$  = Seismic zone coefficient given in Table 6.2.22  
 $I$  = Structure importance coefficient given in Table 6.2.23  
 $R$  = Response modification coefficient for structural systems given in Table 6.2.24  
 $W$  = The total seismic dead load defined in Sec 2.5.5.2  
 $C$  = Numerical coefficient given by the relation :

$$C = \frac{1.25S}{T^{2/3}} \quad (2.5.2)$$

$S$  = Site coefficient for soil characteristics as provided in Table 6.2.25  
 $T$  = Fundamental period of vibration in seconds, of the structure for the direction under consideration as determined by the provisions of Sec 2.5.6.2.

The value of  $C$  need not exceed 2.75 and this value may be used for any structure without regard to soil type or structure period. Except for those requirements where Code prescribed forces are scaled up by  $0.375R$ , the minimum value of the ratio  $C/R$  shall be 0.075.

**Table 6.2.22**  
Seismic Zone Coefficients,  $Z$

Seismic Zone (see Fig 6.2.10)	Zone Coefficient
1	0.075
2	0.15
3	0.25

**Table 6.2.23**  
Structure Importance Coefficients  $I, I'$

Structure Importance Category (see Table 6.1.1 for occupancy)	Structure Importance Coefficient	
	$I$	$I'$
I Essential facilities	1.25	1.50
II Hazardous facilities	1.25	1.50
III Special occupancy structures	1.00	1.00
IV Standard occupancy structures	1.00	1.00
V Low-risk Structures	1.00	1.00

**2.5.6.2 Structure Period :** The value of the fundamental period,  $T$  of the structure shall be determined from one of the following methods :

a) **Method A :** For all buildings the value of  $T$  may be approximated by the following formula :

$$T = C_t (h_n)^{3/4} \quad (2.5.3)$$

where,  $C_t$  = 0.083 for steel moment resisting frames  
 = 0.073 for reinforced concrete moment resisting frames, and eccentric braced steel frames  
 = 0.049 for all other structural systems  
 $h_n$  = Height in metres above the base to level  $n$ .

Alternatively, the value of  $C_t$  for buildings with concrete or masonry shear walls may be taken as  $0.031/\sqrt{A_c}$ . The value of  $A_c$  shall be obtained from the relation :

$$A_c = \sum A_e \left[ 0.2 + (D_e/h_n)^2 \right] \quad (2.5.4)$$

where,  $A_c$  = The combined effective area, in square metres, of the shear walls in the first-storey of the structure.  
 $A_e$  = The effective horizontal cross-sectional area, in square metres of a shear wall in the first storey of the structure.  
 $D_e$  = The length, in metre of a shear wall element in the first storey in the direction parallel to the applied forces.

The value of  $D_e/h_n$  for use in Eq (2.5.4) shall not exceed 0.9.

**Table 6.2.24**  
**Response Modification Coefficient for Structural Systems,  $R$**

Basic Structural System <sup>(1)</sup>	Description of Lateral Force Resisting System	$R$ <sup>(2)</sup>
a. Bearing Wall System	1. Light framed walls with shear panels	
	i) Plywood walls for structures, 3 storeys or less	8
	ii) All other light framed walls	6
	2. Shear walls	
	i) Concrete	6
	ii) Masonry	6
	3. Light steel framed bearing walls with tension only bracing	4
	4. Braced frames where bracing carries gravity loads	
	i) Steel	6
	ii) Concrete <sup>(3)</sup>	4
iii) Heavy timber	4	
b. Building Frame System	1. Steel eccentric braced frame (EBF)	10
	2. Light framed walls with shear panels	
	i) Plywood walls for structures 3-storeys or less	9
	ii) All other light framed walls	7
	3. Shear walls	
	i) Concrete	8
	ii) Masonry	8
	4. Centric braced frames (CBF)	
	i) Steel	8
	ii) Concrete <sup>(3)</sup>	8
iii) Heavy timber	8	
c. Moment Resisting Frame System	1. Special moment resisting frames (SMRF)	
	i) Steel	12
	ii) Concrete	12
	2. Intermediate moment resisting frames (IMRF), concrete <sup>(4)</sup>	8
	3. Ordinary moment resisting frames (OMRF)	
i) Steel	6	
ii) Concrete <sup>(5)</sup>	5	
d. Dual System	1. Shear walls	
	i) Concrete with steel or concrete SMRF	12
	ii) Concrete with steel OMRF	6
	iii) Concrete with concrete IMRF <sup>(4)</sup>	9
	iv) Masonry with steel or concrete SMRF	8
	v) Masonry with steel OMRF	6
	vi) Masonry with concrete IMRF <sup>(3)</sup>	7
	2. Steel EBF	
	i) With steel SMRF	12
	ii) With steel OMRF	6
	3. Centric braced frame (CBF)	
	i) Steel with steel SMRF	10
	ii) Steel with steel OMRF	6
	iii) Concrete with concrete SMRF <sup>(3)</sup>	9
iv) Concrete with concrete IMRF <sup>(3)</sup>	6	
e. Special Structural Systems	See Sec 1.3.2, 1.3.3, 1.3.5	
<b>Notes :</b> (1) Basic Structural Systems are defined in Sec 1.3.2, Chapter 1. (2) See Sec 2.5.6.6 for combination of structural systems, and Sec 1.3.5 for system limitations. (3) Prohibited in Seismic Zone 3. (4) Prohibited in Seismic Zone 3 except as permitted in Sec 2.5.9.3. (5) Prohibited in Seismic Zones 2 and 3. Sec 1.7.2.6.		

Table 6.2.25  
Site Coefficient,  $S$  for Seismic Lateral Forces (1)

Site Soil Characteristics		Coefficient, $S$
Type	Description	
$S_1$	A soil profile with either : a) A rock-like material characterized by a shear-wave velocity greater than 762 m/s or by other suitable means of classification, or b) Stiff or dense soil condition where the soil depth is less than 61 metres	1.0
$S_2$	A soil profile with dense or stiff soil conditions, where the soil depth exceeds 61 metres	1.2
$S_3$	A soil profile 21 metres or more in depth and containing more than 6 metres of soft to medium stiff clay but not more than 12 metres of soft clay	1.5
$S_4$	A soil profile containing more than 12 metres of soft clay characterized by a shear wave velocity less than 152 m/s	2.0
<b>Note :</b> (1) The site coefficient shall be established from properly substantiated geotechnical data. In locations where the soil properties are not known in sufficient detail to determine the soil profile type, soil profile $S_3$ shall be used. Soil profile $S_4$ need not be assumed unless the building official determines that soil profile $S_4$ may be present at the site, or in the event that soil profile $S_4$ is established by geotechnical data.		

- b) **Method B :** The fundamental period  $T$  may be calculated using the structural properties and deformational characteristics of the resisting elements in a properly substantiated analysis. This requirement may be satisfied by using the following formula :

$$T = 2\pi \sqrt{\frac{\sum_{i=1}^n w_i \delta_i^2}{g \sum_{i=1}^n f_i \delta_i}} \quad (2.5.5)$$

The values of  $f_i$  represent any lateral force distributed approximately in accordance with the principles of Eq (2.5.6), (2.5.7) and (2.5.8) or any other rational distribution. The elastic deflections,  $\delta_i$ , shall be calculated using the applied lateral forces,  $f_i$ . The value of  $T$  determined from Eq (2.5.5) shall not exceed that calculated using Eq (2.5.3) by more than 40%.

**2.5.6.3 Vertical Distribution of Lateral Forces :** In the absence of a more rigorous procedure, the total lateral force, which is the base shear  $V$ , shall be distributed along the height of the structure in accordance with Eq (2.5.6), (2.5.7) and (2.5.8):

$$V = F_t + \sum_{i=1}^n F_i \quad (2.5.6)$$

where,  $F_i$  = Lateral force applied at storey level  $-i$  and  
 $F_t$  = Concentrated lateral force considered at the top of the building in addition to the force  $F_n$ .

The concentrated force,  $F_t$  acting at the top of the building shall be determined as follows:







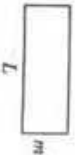

$$F_t = 0.07 TV \leq 0.25 V \quad \text{when } T > 0.7 \text{ second} \quad (2.5.7a)$$

$$F_t = 0.0 \quad \text{when } T \leq 0.7 \text{ second} \quad (2.5.7b)$$

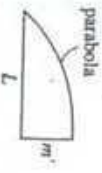
The remaining portion of the base shear ( $V - F_t$ ), shall be distributed over the height of the building, including level- $n$ , according to the relation :

$$F_x = \frac{(V - F_t) w_x h_x}{\sum_{i=1}^n w_i h_i} \quad (2.5.8)$$

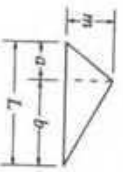
# Table for Evaluating $\int_0^L m m' dx$

$\int_0^L m m' dx$				
	$m m' L$	$\frac{1}{2} m m' L$	$\frac{1}{2} m (m' + m_2) L$	$\frac{2}{3} m m' L$
	$\frac{1}{2} m m' L$	$\frac{1}{3} m m' L$	$\frac{1}{6} m (2m_1 + m_2) L$	$\frac{5}{12} m m' L$
	$\frac{1}{2} m (m_1 + m_2) L$	$\frac{1}{6} m (m_1 + 2m_2) L$	$\frac{1}{6} [m (2m_1 + m_2) + m_2 (m_1 + 2m_2)] L$	$\frac{1}{12} [m (3m_1 + 5m_2) L$
	$\frac{1}{2} m m' L$	$\frac{1}{6} m m' (L + a)$	$\frac{1}{6} m [m' (L + b) + m_2 (L + a)]$	$\frac{1}{12} m m' \left( 3 + \frac{3a}{L} - \frac{a^2}{L^2} \right) L$
	$\frac{1}{2} m m' L$	$\frac{1}{6} m m' L$	$\frac{1}{6} m (2m_1 + m_2) L$	$\frac{1}{4} m m' L$

**The University of Asia Pacific**  
**Department of Civil Engineering**  
**Final Examination Spring 2008**  
**Program: B. Sc. Engineering (Civil)**

Course #CE 315  
 Full Marks: 150

Course Title: Design of Concrete Structures I  
 Time: Three Hours

*There are EIGHT questions in this question paper. Answer any SIX questions. All questions carry equal marks.*

- 1(a) "In USD, the yield strength of steel is used instead of the ultimate strength of steel" – (3)  
 Why?  
 (b) "Tensile yielding of steel is preferable to compression failure of concrete" - Why? (2)  
 (c) Refer to the following fixed supported beam. Design the beam for moment by USD. (20)

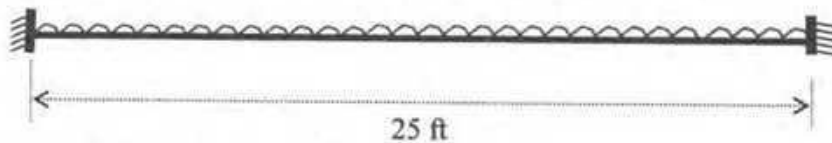

Uniformly distributed working LL = 1000 lb/ft  
 Uniformly distributed working DL (excluding self weight of the beam) = 500 lb/ft  
 Width of the beam = 12 inch (architectural requirement)  
 $[f_y = 60,000 \text{ psi}, f'_c = 4000 \text{ psi}]$ .

- 2(a) Compare WSD and USD. (5)  
 (b) Refer to the following beam section. Calculate the moment capacity of the section using USD and WSD. Make comments on the results. (20)  
 $[f_y = 60,000 \text{ psi}, f_s = 20,000 \text{ psi}, f'_c = 4000 \text{ psi}]$ .

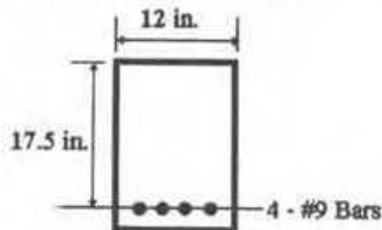

- 3(a) Derive the following equation for the spacing of shear reinforcement of a beam: (8)

$$S = \frac{A_v f_v d}{V_{ext} - V_c}$$

The symbols carry the usual meanings.

- (b) A simply supported rectangular beam of span 20 feet is subjected to a total working load of 5.5 k/ft (including self weight, DL, and LL). Design the shear reinforcement of the beam by WSD. Draw the layout of the stirrups in neat sketches. Width of the beam = 16 inch and effective depth = 22 inch.  $[f'_c = 3000 \text{ psi}, f_v = 20,000 \text{ psi}]$ . (17)

- 4(a) "Maximum shear force is developed at the face of the support but the design shear force is calculated at a distance 'd' (effective depth) from the face of the support" – Why? (4)
- (b) Compare singly reinforced and doubly reinforced concrete beams. (5)
- (c) A simply supported beam of span 18 feet is subjected to LL = 2.5 k/ft, DL (including self weight of the beam) = 1.1 k/ft. Due to the architectural reason, the beam section is fixed at 10 inch by 20 inch. Design the beam for moment. Use USD. [f<sub>y</sub> = 40,000 psi, f'<sub>c</sub> = 3000 psi]. (16)
- 5) Refer to the following beam section: (25)

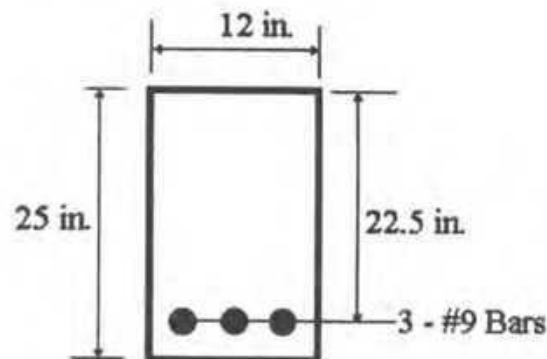

[f<sub>y</sub> = 60,000 psi, f'<sub>c</sub> = 4,000 psi, f<sub>t</sub> = 450 psi, E<sub>s</sub> = 29,000,000 psi].

- (a) Draw the un-cracked transformed section. Determine the location of its neutral axis and the area moment of inertia. Calculate the minimum moment that will cause cracking of concrete (moment for which tensile stress of concrete = 450 psi). (6)
- (b) If M = 40 k-ft, calculate the stresses in concrete at the outermost fibers and also tensile stress in steel. (3)
- (c) If M = 80 k-ft, calculate the stresses in concrete at the outermost fibers and also tensile stress in steel. (3)
- 6(a) Define balanced steel ratio. Derive the following equation for balanced steel ratio: (6)

$$\rho_b = \alpha \frac{0.003}{\frac{f_y}{E_s} + 0.003} \frac{f_c'}{f_y}$$

The symbols carry the usual meanings.

- (b) "The bond strength of top bars is lower than that of bottom bars" – Why? (3)
- (c) "Plain bars have lower bond strength than deformed bars" – Why? (3)

- (d) The SFD of a beam is given below with the magnitude of shear forces at the critical locations at (i), (ii), and (iii). (13)

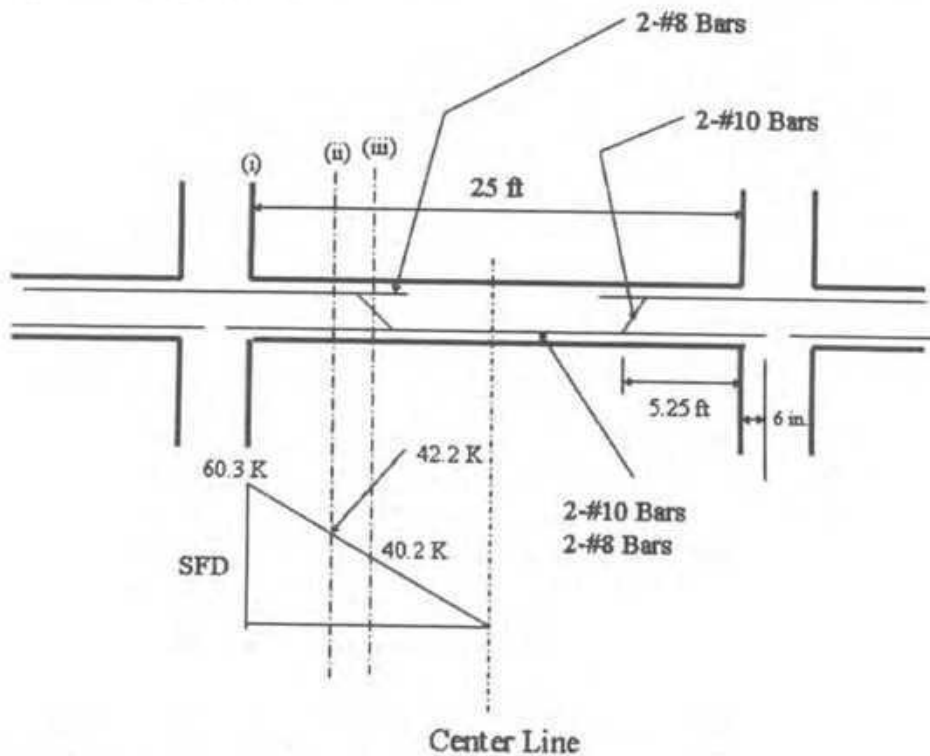

Check the bond stresses at the specified critical locations by USD.  
 Effective depth of the beam = 23 inch. [ $f'_c = 3500$  psi,  $f_y = 40,000$  psi].

- 7(a) "The capacity reduction factor for shear is less than that for moment" – Why? (3)  
 (b) Explain the importance of using the following factors in USD (5)  
 (i) load factors, and  
 (ii) capacity reduction factors  
 (c) Refer to the following beam section. Calculate the ultimate moment capacity of the section. [ $f'_c = 3000$  psi,  $f_y = 60,000$  psi]. (17)

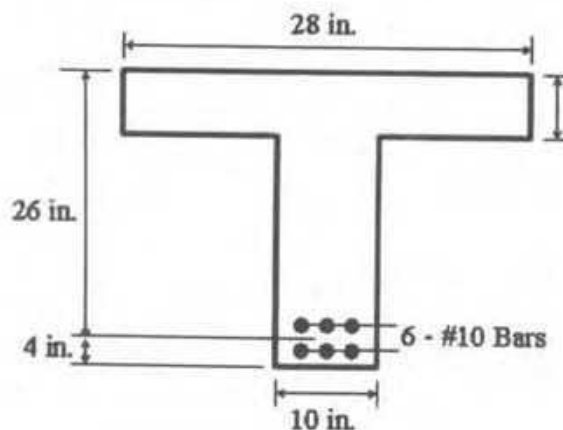

- 8(a) "The temperature and shrinkage reinforcement for slab is placed at the top of the positive steel and at the bottom of the negative steel" – Why? (5)
- (b) Refer to the following slab rigidly connected (fixed support) with the peripheral walls. Design the slab by USD. Show the details of the reinforcements. (20)

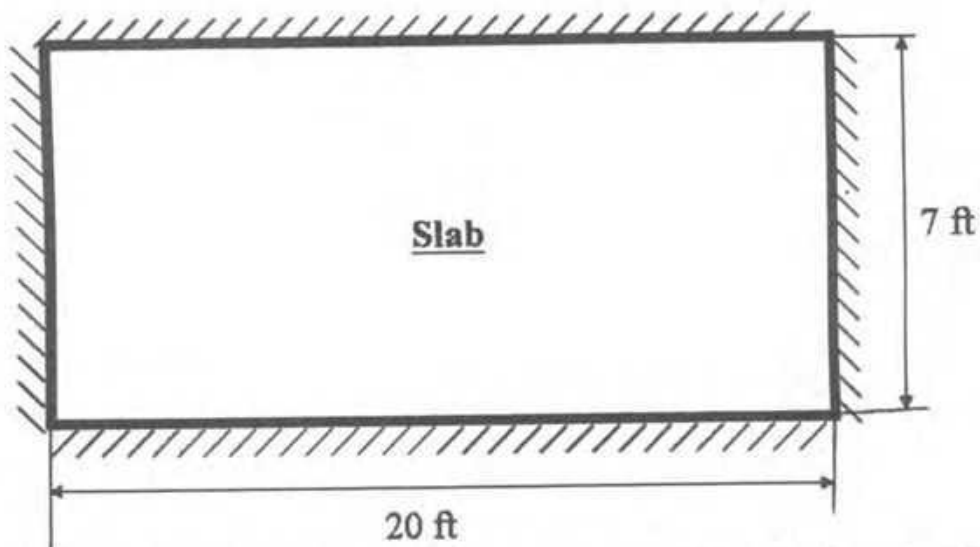

[ $f'_c = 3500$  psi,  $f_y = 60,000$  psi, LL = 100 psf, Floor Finish = 15 psf, Partition Wall = 30 psf].

55

**The University of Asia Pacific**  
**Department of Civil Engineering**  
**Final Examination Spring 2008**  
**Program: B.Sc. Engineering (Civil)**

Course Title: Environmental Engineering II  
Time: 3.0 hours

Course Code: CE 333

Credit: 3.00  
Full Marks: 150

---

There are **TWO** sections in the question paper namely "SECTION A" and "SECTION B". You have to answer from the both sets according to the instruction mentioned on each section.

---

**SECTION A**

Answer any 3 (THREE) questions. Figures in the right margin indicate full marks.

- 1 a. Mismanagement and irregularities in operation and maintenance of the DHAKA city sewerage system is creating an environmental hazard for city dwellers. As an environmental expert write down some recommendation(s) for the improvement of sewerage system in Dhaka. 6
- b. Define the following terms,  
(i) Peak dry weather flow (ii) Peak wet weather flow 4
- c. Define with neat sketches wherever necessary: Sewage, Sullage, Sewer, Trunk Sewer, Relief Sewer 5
- d. Write down some advantages and disadvantages of *separate* and *combined* sewerage systems. Which one is suitable for Dhaka city and why? 5
- e. Briefly discuss the tasks of an engineer in wastewater management. 5
- 2 a. Determine the discharge and velocity in a 30 cm circular sewer with  $n = 0.013$ , slope  $S = 0.004$  and depth of flow equal to 7.5 cm. (Use enclosed hydraulic elements diagram, figure 1) 5
- b. Calculate the wastewater quantity ( $m^3/day$ ) from a small town of 50,000 inhabitants. Total area of the town is 3000 ha. The average water consumption is 140 l/day/capita. A small factory, located in the town, occupied an area of 1500 ha producing 0.30 l/s/ha wastewater. A hotel along with other commercial area occupied 200 ha producing 1.0 l/s/ha wastewater. Assume, peak dry weather factor = 1.7, infiltration factor = 0.5 and ground water constant = 0.4 l/s/ha. 7
- c. A long storm sewer collects water from a catchment area of 0.45  $km^2$ , where 35% area is covered by roof ( $C = 0.9$ ), 20% area covered by paved roads ( $C = 0.8$ ) and 45% area covered by open land ( $C = 0.13$ ). Determine the diameter of the storm sewer. Assume: Rainfall duration ( $t$ ) = 15 minutes, 50% flow condition,  $S = 0.001$  m/m and  $n = 0.013$ . 8
- d. Calculate the wastewater quantity ( $m^3/day$ ) of a small town of 60,000 inhabitants. The average water consumption is 150 l/day/capita. A small factory locates in the town, has a daily production capacity of 7200 kg. Each kg produced wastewater in average as much as 1.7 inhabitants. There is also a hotel consists of 200 rooms with an average of two beds per room 5

and a restaurant with a capacity of 280 persons in the town. Assume, IE of restaurant seats and beds are 0.2 and 1.5 respectively.

- 3 a. What are the objectives of wastewater treatment? What is pretreatment? 4
- b. Draw a schematic diagram of a treatment plant showing its various units. 4
- c. Define and differentiate between discrete and flocculated particles 4
- d. Assuming that all particles with settling velocity  $V_s > V_c$  will be removed and particles with  $V_s < V_c$  will be removed in the proportion  $\frac{V_s}{V_c}$ , What will be the percentage removal of particles having diameter as follows. 8

Diameter (mm)	0.010	0.015	0.020	0.025	0.030	0.035	0.040
---------------	-------	-------	-------	-------	-------	-------	-------

The sediment tank has an overflow rate of  $25 \text{ m}^3/\text{m}^2\text{d}$ . Take  $V = 0.01 \text{ cm}^2/\text{s}$  and density of sediment particles  $2 \text{ gm/cc}$ .

- e. Give various methods and means of disinfecting of wastewater. 5
- 4 a. Draw a schematic diagram showing various components of a septic tank. 4
- b. Design a septic tank to serve a household of ten persons who produce 90 lpcd of wastewater. The tank is to be desludged every six years. 12
- c. If the soil is sandy loam with a long-term infiltration rate of about  $30 \text{ l/m}^2 \text{ day}$ . Design a soakage pit for a septic discharging 900 litre effluent everyday. (Assume pit dia = 1.25 m) 4
- d. Write a short note on septic tank design suggested by Bangladesh National Building Code. 5

### SECTION B

Answer any 3 (THREE) questions. Figures in the right margin indicate full marks.

- 5 a. Describe the activated sludge process in detail and give the flow diagram. 10
- b. What are the relative advantages and disadvantages of Activated Sludge over Trickling Filter? 4
- c. Briefly discuss the common problems associated with trickling filter treatment process. 4
- d. When will you provide tertiary treatment facilities in wastewater treatment? 2
- e. Calculate the effluent BOD of a trickling filter having a depth of 2 m and a recirculated rate of 125 percent of the flow. The influent BOD is  $170 \text{ mg/l}$  following primary treatment. (Use Velz formula with  $K=0.49$ ) 5

- 6 a. Differentiate between (i) Aerobic and Anaerobic process 5  
(ii) Nitrification and Denitrification
- b. Design a waste stabilization pond system to treat wastewater from a low-income settlement with a population of 4,000 at Mirpur, Dhaka. The average wastewater flow is about 100 litres per person per day and the BOD<sub>5</sub> is 400 mg/l. The mean temperature is 23°C. Assume faecal coliform concentration in raw wastewater is  $1 \times 10^5$  per 100 ml. Assume, Anaerobic, Facultative and Maturation pond depths are 3 m, 1.5 m and 1.25 m respectively, Length : Breadth = 3:1,  $K_T$  at 23°C = 6.2 per day, 50% removal efficiency in the facultative pond, 75% surface loading during maturation pond design and consider only one maturation pond. You can assume any other reasonable data, if necessary. What would be the faecal coliform concentration in the treated wastewater. 20
- 7 a. What are the common methods used for sewage and effluent disposal? What will be the positive and negative affects, if the effluents are disposed on land? 5
- b. A municipal wastewater treatment plant discharges secondary effluent to a surface stream. The worst conditions are known to occur in the summer months when stream flow is low and water temperature is high. Under these conditions, from measurements made in the laboratory as well as in the field, the wastewater is found to have a maximum flow rate of 15,000 m<sup>3</sup>/day, a BOD<sub>5</sub> of 40 mg/L, a DO concentration of 2 mg/L and a temperature of 25° C. The stream (upstream from the point of wastewater discharge) is found to have a minimum flow rate of 0.5 m<sup>3</sup>/s, a BOD<sub>5</sub> of 3 mg/L, a DO concentration of 8 mg/L and a temperature of 22° C. Complete mixing of the wastewater and stream is almost instantaneous and the velocity of mixture is 0.2 m/s. The values of  $K_1$  and  $K_2$  at 20° C are 0.3/d and 0.7/d respectively. Use the temperature coefficient of 1.135 for  $K_1$  and 1.024 for  $K_2$ . Determine – 20  
(i) the critical oxygen deficit, critical (minimum) DO and its location along the stream.  
(ii) the DO at 120 km and 200 km downstream of the point of discharge of sewage.  
(iii) If 4.0 mg/L be the minimum DO requirement for the survival of aquatic lives in a stream, then comment on the stream health from the perspective of aquatic lives.
- 8 a. Design a leach pit for alternating twin off-set pit pour-flush latrines serving a family of ten members living in a peri-urban area. The family uses water for anal cleansing. The wastewater flow is 20 lcd and the soil is porous silty loam. Assume the desludging interval as 2 years. 10
- b. Describe with neat sketch, the stages of water pollution and self purification process of a river after the disposal of sewage or effluent in that river. 10
- c. What are the importance of sludge management? Write down the names of several sludge treatment and disposal methods. 5

**Table-1:** Design values of  $\lambda_v$  and BOD removal rate at various temperature  
[Use for problem 6(b)]

Temperature(°c)	Volumetric loading rate (g BOD/m <sup>3</sup> day)	BOD removal (%)
20	300	60
21	300	62
22	300	64
23	300	66
24	300	68
>25	300	70

**Table-2:** Design values for surface BOD loading rates for facultative ponds at various temperatures  
[Use for problem 6(b)]

Temperature(°c)	Surface loading rate (kgBOD/ha.day)	Temperature(°c)	Surface loading rate (kgBOD/ha.day)
16	183	21	272
17	199	22	292
18	217	23	311
19	235	24	331
20	253	25	350

**Table-3:** Design values for long term infiltration rates for wastewater into various soils  
[Use for problems 4(c) and 8(a)]

Soil Type	Long-term infiltration rate (l/m <sup>2</sup> -day)
Sand	50
Sandy loam	30
Porous silty loam, porous silty clay loam	20
Compact silty loam, clay	10

**Table-4:** Values of solid accumulation rates (m<sup>3</sup>/person/year)  
[Use for problems 4(c) and 8(a)]

Wet Pit		Dry Pit	
Anal cleansing: Water	Anal cleansing: Solids	Anal cleansing: Water	Anal cleansing: Solids
0.04	0.06	0.06	0.09

Formulae:

ANNEXURE

1	$Q = \sum D.d + \sum I.i$	2	$\sum D = P.q_r + A_c q_c + A_i q_i$
3	$Q = FCIA$ [ use $F = 0.278$ ]	4	$C = \frac{a_1}{A} c_1 + \frac{a_2}{A} c_2 + \dots$
5	$I = \frac{76.2}{t+10}$ cm/hr	6	$t_c = \frac{FL}{A^{0.1} S^{0.2}}$ (use $F = 58.5$ )
7	$V = \frac{1}{n} R^{\frac{2}{3}} S^{\frac{1}{2}}$	8	$L_t = L_0 e^{-kt}$
9	$Y_t = L_0 (1 - e^{-kt})$	10	$K_{corrected} = K_{20} (1.047)^{T-20}$
11	$L_0 = \frac{L_s q_s + L_b q_b}{Q_b + q_s}$	12	$DO_0 = \frac{DO_s q_s + DO_b q_b}{Q_b + q_s}$
13	$DO_{sat} = 14.62 - 0.4042 T + 0.00842 T^2 - 0.00009 T^3$		
14	$D_{crit} = \frac{K_1}{K_2} L_0 e^{-K_1 t_c}$	15	$X_{crit} = v t_{crit}$
16	$t_{crit} = \frac{1}{K_2 - K_1} Ln \left[ \frac{K_2}{K_1} \left( 1 - \frac{D_0 (K_2 - K_1)}{K_1 L_0} \right) \right]$	17	$DO_{crit} = DO_{sat} - D_{crit}$
18	$V_s = \frac{g}{18\nu} \frac{\rho_s - \rho}{\rho} d^2$	19	$C_s = \left( \frac{C_i + r C_e}{1+r} \right) e^{-\lambda x}$
20	$V = V_b + V_d + 1.4 V_{sl}$ $V_{sc} = 0.4 V_{sl}$ $t_h = 1.5 - 0.3 \log(Pq)$ $V_b = 10^{-3} Pq t_h$	$t_d = 30 (1.035)^{35-T}$ $V_d = 0.5 \times 10^{-3} P t_d$ $V_{sl} = C \times P \times N$ $d_{sc} = 0.82 - 0.26A$	$\lambda_s = LQ/V_s$ $\lambda_s = 10LQ/A_r$ $K_r = 2.6(1.19)^{(T-20)}$ $\theta = V/Q$ $N_s = N_i / (1 + K_r \theta_s) (1 + K_r \theta_r) (1 + K_r \theta_n)$ $\theta_n = \left\{ N_i / N_s (1 + K_r \theta_s) (1 + K_r \theta_r) \right\}^{1/2} - 1 / K_r$
22	$V_s = C * P * N$ $A_i = Q / I$ $V_i = (A_i * D) / 4$ $h_i = V / (\pi D^2 / 4)$		

60  
**Figure-1:** Hydraulic elements diagram for circular sewer [Use for problem 2(a)]

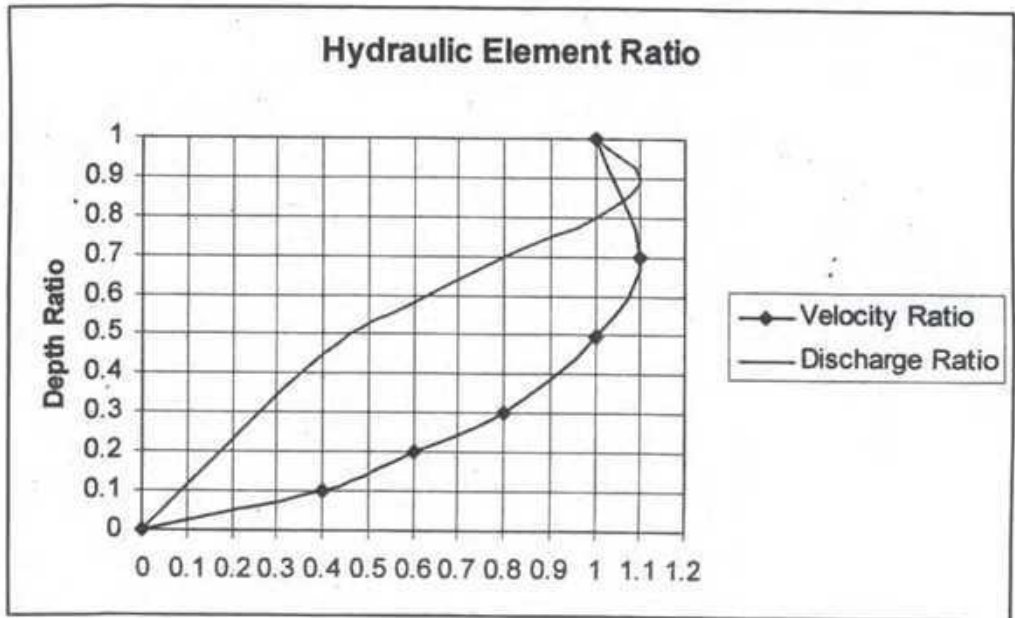

92

CE 403  
Professional Practices and Communication  
Final Examination  
Department of Civil Engineering  
University of Asia Pacific  
Total marks: 100  
Time: 2 Hours

Answer all of the questions given below:

1. What is a contract? What are the essential elements of a contract? Describe the different classes of contract for civil engineering works. Enumerate briefly the advantages and disadvantages of each type of contract.
2. Define a project. Describe the characteristic features of a project and explain them using a typical project life cycle curve.
3. What is a tender and what are the three stages of a tender procedure? Explain the activities that are carried out in different stages of tender procedure.
4. Answer the following questions with reference to the "Code of Ethics for Engineers" document as supplied to you.
  - (a) According to the preamble, whom should the engineer serve?
  - (b) According to section 8, when a conflict of interest with his employer or client becomes unavoidable, what should the engineer do?
  - (c) According to section 10, under what condition can an engineer accept financial or other compensation from more than one interested party for the same service?
  - (d) According to section 12, if an engineer believes another engineer to be guilty of unethical or illegal practice, what should he do?
  - (e) According to section 13, an engineer should become professionally associated with what kind of engineers?

**The University of Asia Pacific**  
**Department of Civil Engineering**  
**Final Examination Spring 2008**  
**Program: B. Sc. Engineering (Civil)**

Course Title: Structural Engineering III  
 Time: 3 hours

Credit Hours: 3.0

Course Code: CE 411  
 Full Marks: 100 (= 10 × 10)

[Answer any 10 (ten) of the following 14 questions]

1. Use the Stiffness Method (considering flexural deformations only) to calculate the rotations at joint C and D of the beam ABCDE shown below, if in addition to the applied loads, support D settles 0.05' downwards [Given:  $P = 0$ ,  $EI_{DE} = 20 \times 10^3 \text{ k-ft}^2$ ,  $EI_{ABCD} = EI_{DE}/2$ ].

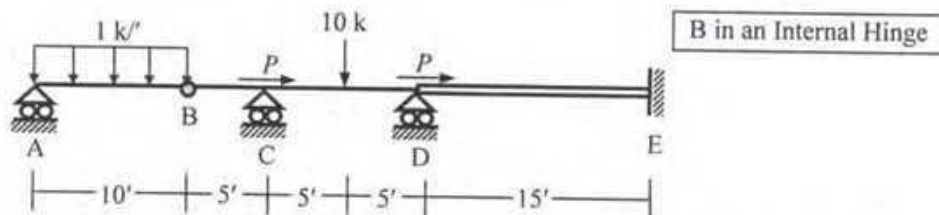

2. Use the Moment Distribution Method to draw the bending moment diagram of the beam ABCDE described in Question 1.
3. For the beam ABCDE described in Question 1, calculate the maximum value of  $R_D$  (the reaction at support D) for a uniformly distributed dead load of 1 k/ft and a moving uniformly distributed live load of 0.5 k/ft (no support settlement).
4. Use the Stiffness Method to calculate the value of the force  $P$  to cause buckling of the beam ABCDE shown in Question 1.
5. Use bending moment diagram of the beam ABCDE loaded as shown below to calculate the force  $P$  needed to develop plastic hinge mechanism [Given:  $\sigma_{yp} = 40 \text{ ksi}$ ].

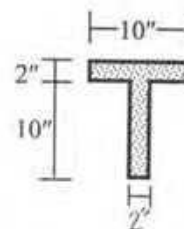
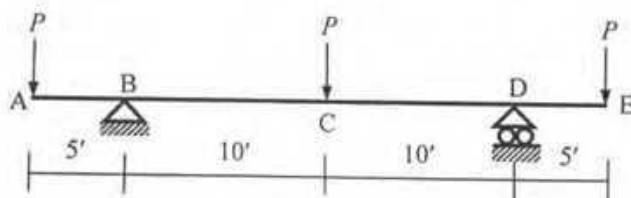

Cross-section of the beam

6. Use the Energy Method to calculate the plastic moment  $M_p$  needed to prevent the development of plastic hinge mechanism in the beam ABCD loaded as shown below, if  $w = 5 \text{ k/ft}$ ,  $P = 50 \text{ kips}$  [Given:  $M_{p(AB)} = M_{p(BC)} = M_p$ ,  $M_{p(CD)} = 2M_p$ ].

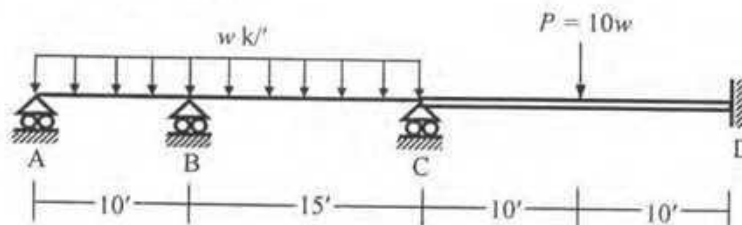

7. Use the Stiffness Method (with flexural deformations only) to calculate the vertical deflection at joint A and rotation at joint B of the frame shown below [Given:  $EI = \text{constant} = 40 \times 10^3 \text{ k-ft}^2$ ].

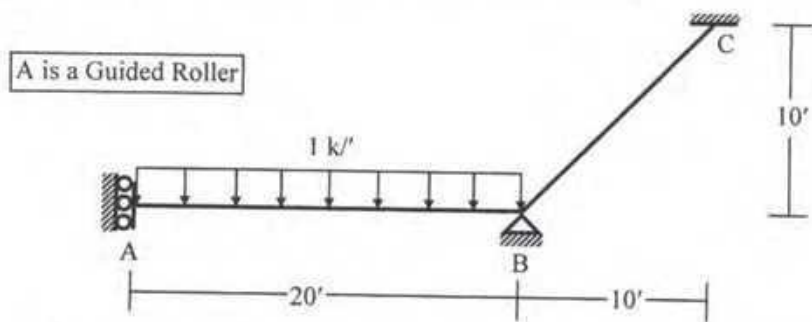

8. Use the Moment Distribution Method to draw the bending moment diagram of the frame described in Question 7 [Use symmetry to extend the structure about A].
9. For the truss shown below, the force in member BC is 10 k (tension). Calculate the applied load  $P_x$  forces in the other members of the truss and the horizontal and vertical deflections of joints A and G [Given:  $EA/L = \text{constant} = 1000 \text{ kip/ft}$ ].

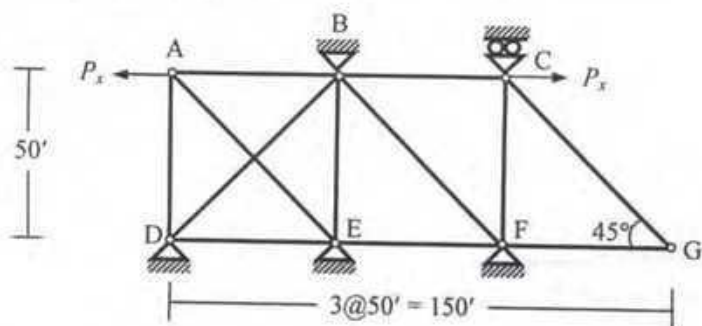

10. For the truss described in Question 9, ignore the zero-force members and formulate the stiffness matrix, load vector and write down the boundary conditions.
11. In the three-dimensional truss ABCD shown below, ignore the zero-force members and formulate the stiffness matrix, load vector and write down the boundary conditions [Given:  $EA/L = \text{constant} = 500 \text{ kip/ft}$ ].

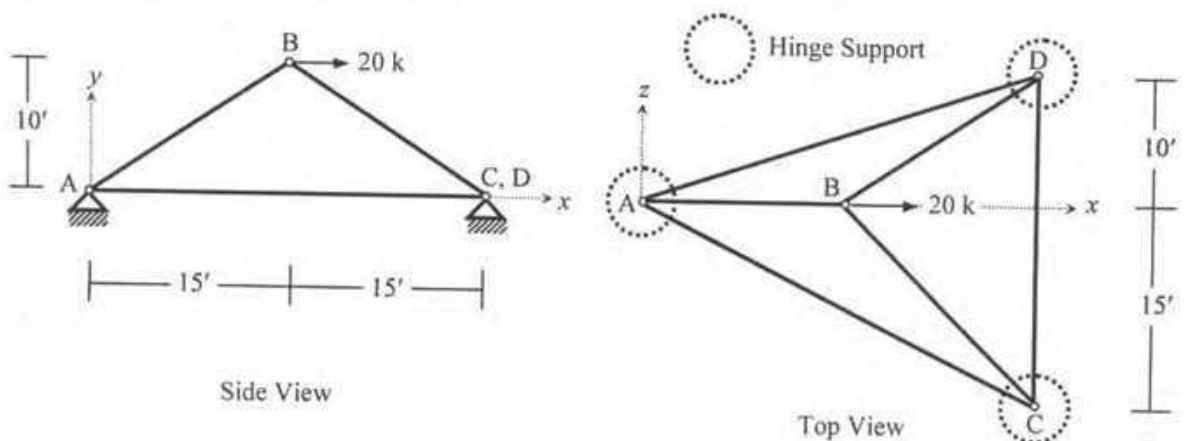

Nodal Coordinates

A (0, 0, 0), B (15, 10, 0), C (30, 0, -15), D (30, 0, 10)

12. For the grid loaded as shown below, use the Stiffness Method to calculate the rotations at C about the  $x$ - and  $z$ -axis [Given:  $EI = 40 \times 10^3 \text{ k-ft}^2$ ,  $GJ = 30 \times 10^3 \text{ k-ft}^2$ ].

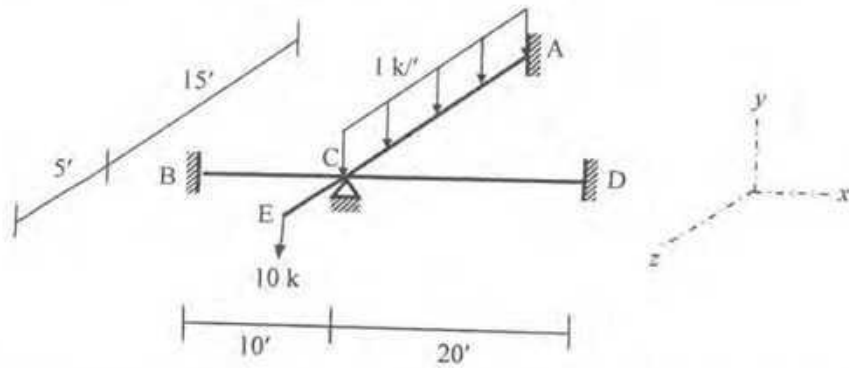

13. Determine the size of the stiffness matrices (considering boundary conditions also) of the frames shown below. Also determine the size of the stiffness matrices if axial deformations are neglected.

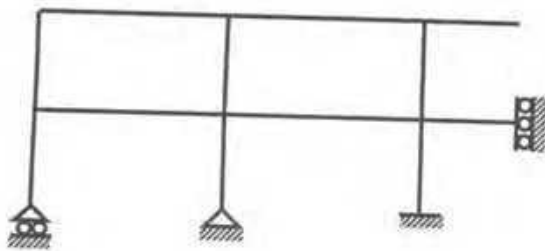

2D Frame

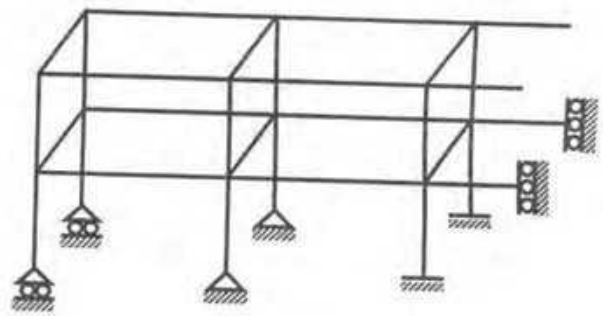

3D Frame

14. (i) Explain why rotations are not considered in calculating the  $dof$  of trusses.
- (ii) Mention the member properties and material properties necessary for the analysis of 3D frames.
- (iii) Explain the terms *Flexural Stiffness* and *Shear Stiffness* of frame members.
- (iv) Mention the difference between 2D Frame and Grid in terms of  $dof$  and direction of loading.
- (v) Explain why deflections and rotations calculated by linear structural analysis can be magnified if *Geometric Nonlinearity* is considered.

**The University of Asia Pacific**  
**Department of Civil Engineering**  
**Final Examination Spring 2008**  
**Program: B. Sc Engineering (Civil)**

Course Title: Structural Engineering VI    Course Code: CE 417  
 Time: 2.00 Hours

Credit: 2.00  
 Full Marks: 100 (= 20 × 5)

Answer any FIVE of the following SEVEN questions

**Question 1:**

a) For a bolted joint subjected to tension show that,

[08]

$$\frac{L_e}{D} = \frac{0.714 f_e}{F_u} + \frac{1}{2}$$

Where the symbols have their usual meanings. Make necessary assumptions to reduce the above expression into the usual forms as used in AISC/ASD and AISC/LRFD specifications.

b) Write the AISC-LRFD load combinations and load resistance factors for different types of members.

[04]

c) Design the weld for end connection required to transmit a DL= 100 kips and a LL=200 kips through two L6×4×3/4 (unequal leg with long legs back to back) tension member shown in Fig.1 to a 1" gusset plate. All material is A36. Welds are to be deposited manually using E70XX electrodes at the three edges (one transverse and two longitudinal). Use AISC/ASD method.

[08]

*[Annexure 1 and 3 provide relevant tables]*

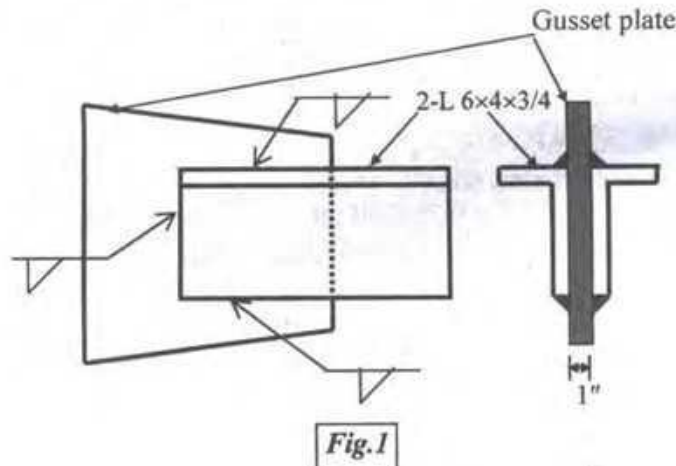

**Question 2:**

a) What is residual stress? Show the residual stress pattern in a W section.

[02]

b) Define Slip-critical connection with sketches.

[04]

c) Determine the equations for the stress-strain behavior in tension of the 20"×1" plate with the residual stresses shown in Fig.2. Draw a qualitative stress-strain diagram and indicate the equations in the curve [Given:  $F_y=36$  ksi,  $E=30,000$  ksi].

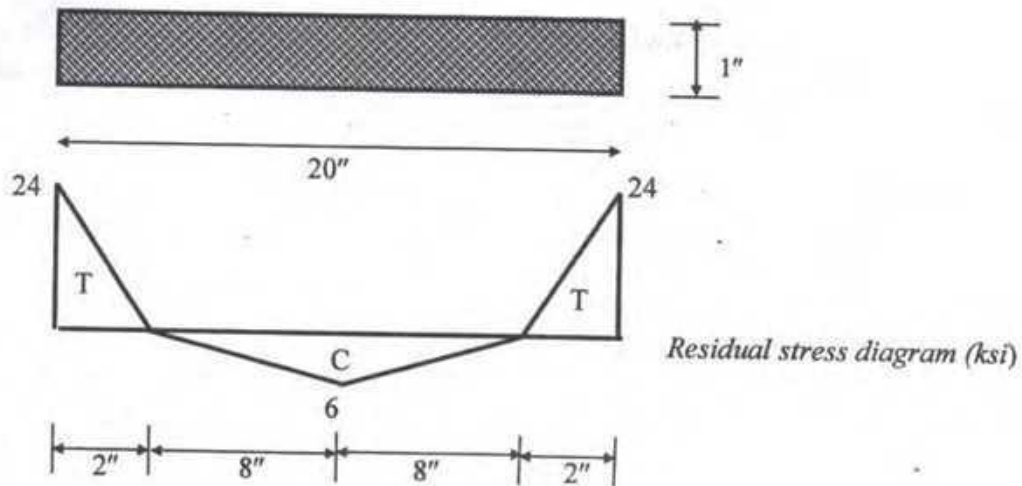

Fig.2

**Question 3:**

a) Write short notes on

i) Effective net area, ii) Block shear in tension member.

b) Determine the design load,  $P$  by AISC/LRFD for a 14"×1/2" steel plate connected to a 3/4" thick gusset plate as shown in Fig.3. Holes are for 7/8" diameter bolts and the plate is made from A36 ( $F_y=36$  ksi,  $F_u=58$  ksi) structural steel. Assume design shearing strength of the bolts = 48 ksi. Investigate all failure modes.

Given: Design strength for gross area,  $\phi_t P_n = 0.9F_y A_g$

Design strength for effective net area,  $\phi_t P_n = 0.75F_u A_e$

Design bearing strength for steel,  $\phi_t P_n = 0.75 \times 2.4F_u d t$

Design strength for block shear,  $\phi R_n = \begin{cases} 0.75(0.60F_y A_{gv} + F_u A_{nt}) \\ 0.75(0.60F_u A_{nv} + F_y A_{gt}) \end{cases}$

Reduction coefficient,  $U=0.85$

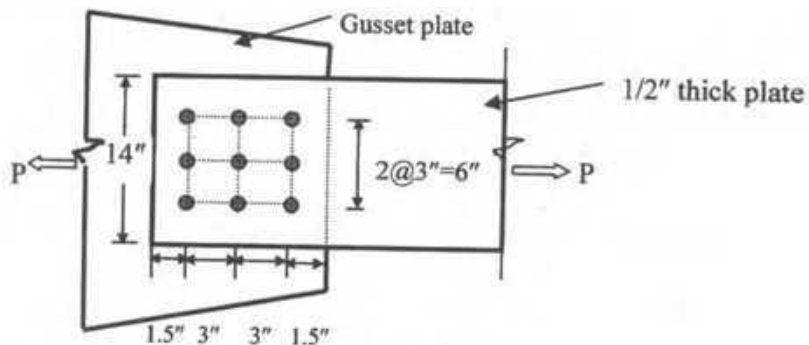

Fig.3

**Question 4:**

a) Differentiate between stiffened and unstiffened elements with neat sketches. [02]

b) Design the lightest W14 section ( $F_y=50$  ksi) for Column AB as shown in Fig. 4. Use AISC/LRFD method of design. [18]

Given: DL=45 kips and LL=140 kips for Column AB.

Assume: (i) Column is oriented in such a way that the major axis bending occurs in the plane of the frame. (ii) Columns are braced at each story level for out-of-plane buckling. ( $K_y=1.0$ )

(iii) The same column section is used for all stories.

[Annexure -1, 2 and 4 provide necessary nomographs, formulas and tables]

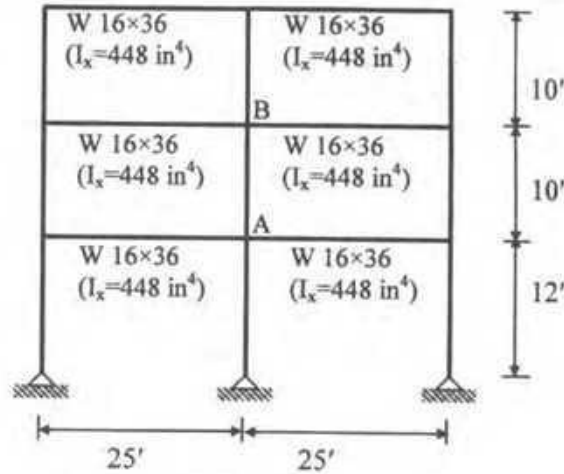

Fig. 4

**Question 5:**

a) Define: i) Local buckling, ii) Compact section [04]

b) Determine the critical load P for the frame of Fig. 5. All members are made of A36 steel. The column is placed with its web in the plane of frame and is supported against buckling out of plane. [16]

Given:  $F_{cr} = F_y \left[ 1 - \frac{1}{2} \left( \frac{KL/r}{C_c} \right)^2 \right]$ , where  $C_c = \pi \sqrt{\frac{2E}{F_y}}$  for buckling in the inelastic range and

$$F_E = \frac{\pi^2 E}{\left( \frac{KL}{r} \right)^2} \text{ for buckling in the elastic range and } E=30,000 \text{ ksi}$$

[Annexure -1 provides necessary nomographs.]

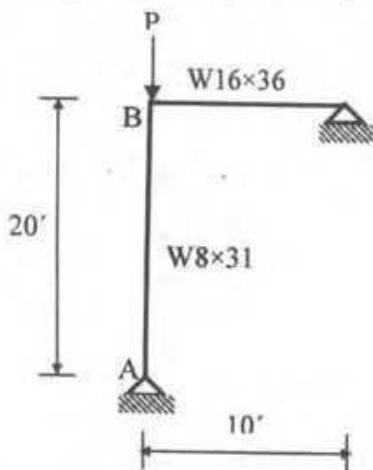

Beam	Column
W16x36	W8x31
$I_x = 448 \text{ in}^4$	$I_x = 110 \text{ in}^4$
$A = 10.60 \text{ in}^2$	$A = 9.13 \text{ in}^2$
$r_x = 6.51 \text{ in}$	$r_x = 3.47 \text{ in}$

Fig. 5

**Question 6:**

a) Define lateral torsional buckling with figure. How can lateral support be provided to prevent lateral torsional buckling? Explain with sketches. [04]

b) The section shown in Fig.6 (a) is selected to be used as beam. Find the value of yield moment ( $M_y$ ), plastic moment ( $M_p$ ) and shape factor of this section about x axis (Use  $F_y = 36$  ksi). [06]

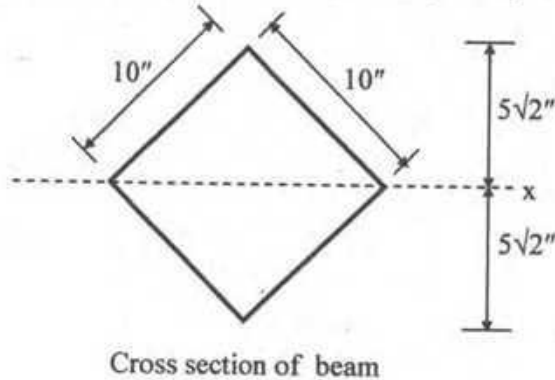

**Fig. 6(a)**

c) The expression for critical moment for lateral torsional buckling is given by [10]

$$M_{x_{cr}}^2 = C_b^2 \left[ \frac{\pi^2}{(kL)^2} EI_y GJ + \frac{\pi^4}{(kL)^4} EI_y EC_w \right] \quad (1)$$

$$F_{cr} = \frac{M_{x_{cr}}}{S_x} \quad (2)$$

Neglecting the 2<sup>nd</sup> term of eq<sup>n</sup> (1) and using eq<sup>n</sup> (2), derive

$$F_{cr} = \frac{20000C_b}{\frac{KLd}{A_f}} \text{ for the I section shown in the Fig.6(b).}$$

Assuming,  $t_w \ll t$ ,  $E = 29,000$  ksi [Each symbol carries its usual meaning].

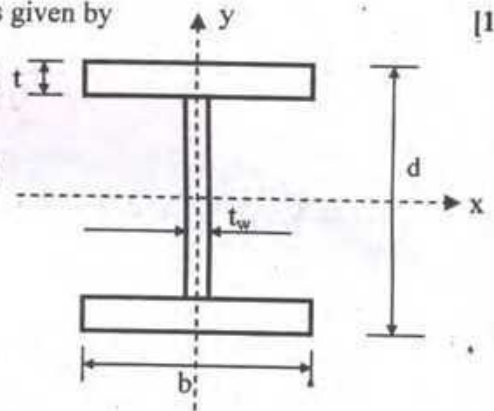
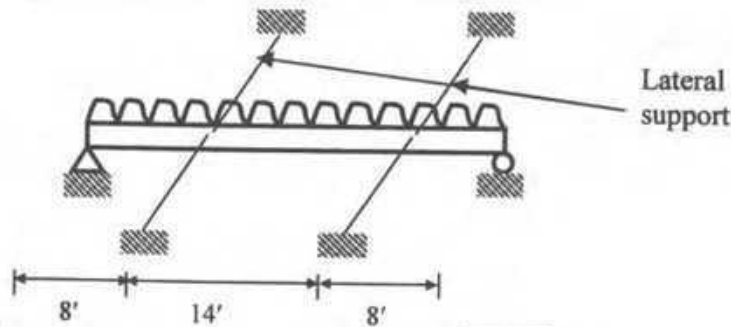

**Fig. 6(b)**

**Question 7:**

Select the lightest W section to carry a uniformly distributed live load 1.5 k/ft and dead load (excluding the wt of the beam) of 0.40 k/ft on a 30 ft span simply supported beam as in Fig.7. Lateral supports are provided at 8 ft from each support. Use steel with  $F_y = 50$  ksi and AISC/ASD method of design. Live load deflection is to be limited to 1/300 of the span. [20]

[Annexure -2 and 5 provide relevant formulas and section properties]



**Fig. 7**

Annexure-1

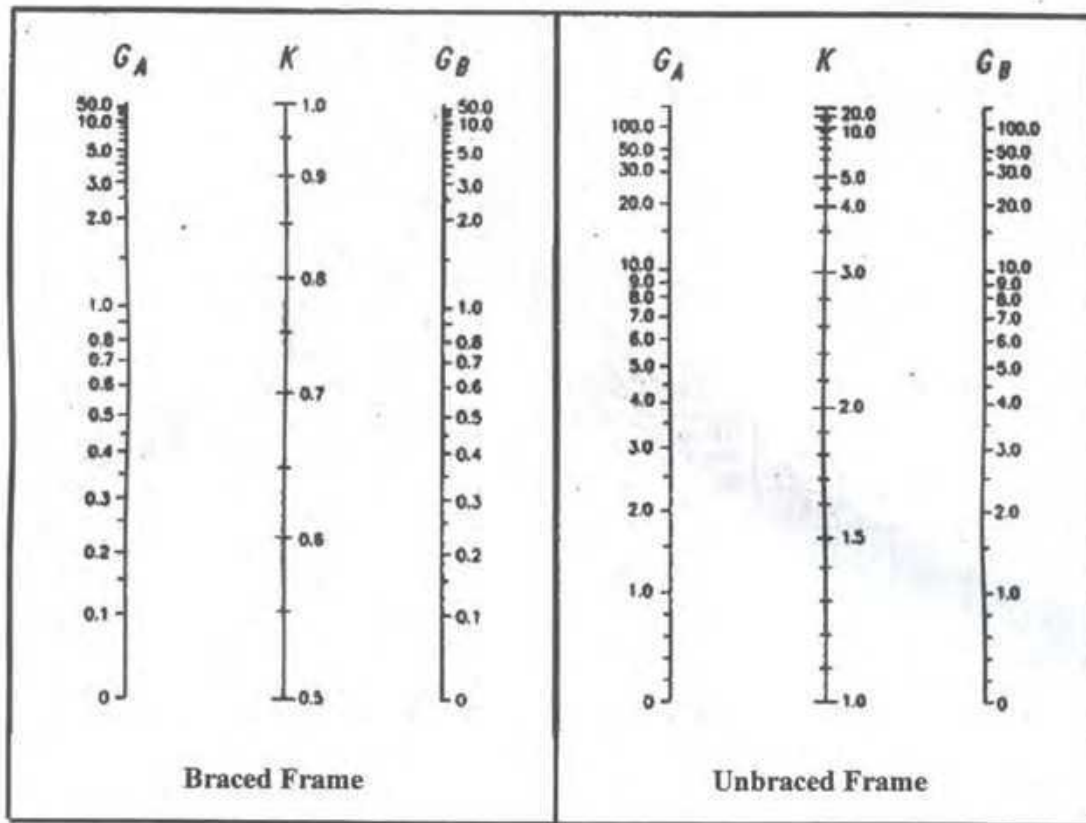

Nomograph for effective length of columns in continuous frames.

Correction factors for beam stiffness		
Condition	Side sway	No side sway
Far end of beam hinged	1/2	3/2
Far end of beam fixed	2/3	2

Minimum size of fillet weld

Material Thickness of Thicker part joined (in.)	Minimum Size of Fillet Weld (in.)
To 1/4	1/8
Over 1/4 to 1/2	3/16
Over 1/2 to 3/4	1/4
Over 3/4	5/16

Maximum size of fillet weld

Material Thickness of Thinner part joined (in.)	Maximum Size of Fillet Weld (in.)
To 1/4	Thickness of the material
Over 1/4 to 1/2	Thickness of the material - 1/16
Over 1/2 to 3/4	Thickness of the material - 1/16
Over 3/4	Thickness of the material - 1/16

## Annexure-2

**Formulas** (the symbols carry their usual meaning)

$$L_c = \begin{cases} \frac{76b_f}{\sqrt{F_y}} \\ \frac{20000}{F_y} \frac{d}{A_f} \end{cases}$$

$$F_b = 0.6F_y \text{ if } L_c < L < L_u = \begin{cases} \frac{20000C_b}{\frac{d}{A_f} F_y} \\ r_T \sqrt{\frac{102000C_b}{F_y}} \end{cases}$$

$$F_b = \begin{cases} \frac{12000C_b}{L \frac{d}{A_f}} \\ \left[ \frac{2}{3} - \frac{F_y \left(\frac{L}{r_T}\right)^2}{1530 \times 10^3 C_b} \right] F_y \end{cases} \quad \text{But not greater than } 0.6F_y; \text{ if } \frac{L}{r_T} \leq \sqrt{\frac{510000C_b}{F_y}}$$

$$F_b = \begin{cases} \frac{170000C_b}{\left(\frac{L}{r_T}\right)^2} \\ \frac{12000C_b}{L \frac{d}{A_f}} \end{cases} \quad \text{But not greater than } 0.6F_y; \text{ if } \frac{L}{r_T} > \sqrt{\frac{510000C_b}{F_y}}$$

$C_b = 1.75 + 1.05(M_1/M_2) + 0.3(M_1/M_2)^2 \leq 2.3$  Where,  $M_1$  is the smaller of the two end moments  $M_1$  and  $M_2$ ,  $M_1/M_2$  is positive for reverse-curvature bending.

- $\phi_c P_n = \phi_c A_g F_{cr}$   
 $= 0.85 A_g F_{cr}$

For  $\lambda_c \leq 1.5$       $F_{cr} = (0.658^{\lambda_c^2}) F_y$

For  $\lambda_c > 1.5$       $F_{cr} = \left[ \frac{0.877}{\lambda_c^2} \right] F_y$

where  $\lambda_c = \frac{KL}{r\pi} \sqrt{\frac{F_y}{E}}$ ,  $E = 29000$  ksi

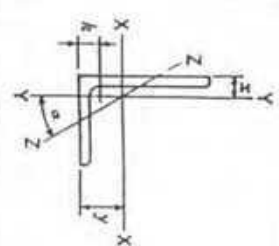

ANGLES  
Equal legs and unequal legs  
Properties for designing

Size and Thickness	k	Weight per foot	Area	AIS X X						AIS Y Y						AIS Z Z		
				I	S	r	y	I	S	r	x	r	Tan α					
L 9 x4 x 3/8	1 1/2	26.3	7.73	64.9	11.5	2.90	3.36	8.32	2.65	1.04	0.858	8.47	0.216					
	1 1/4	23.8	7.00	59.1	10.4	2.91	3.33	7.63	2.41	1.04	0.834	8.50	0.218					
	1 1/8	21.3	6.25	53.2	9.34	2.92	3.31	6.92	2.17	1.05	0.810	8.54	0.220					
	1	18.8	5.50	47.3	8.27	2.93	3.29	6.21	1.92	1.06	0.786	8.57	0.222					
	3/4	16.3	4.75	41.4	7.20	2.94	3.27	5.50	1.67	1.07	0.762	8.60	0.224					
	1/2	13.8	4.00	35.5	6.13	2.95	3.25	4.79	1.42	1.08	0.738	8.63	0.226					
L 8 x8 x1 1/8	1 1/2	56.9	16.7	98.0	17.5	2.42	2.41	98.0	17.5	2.42	2.41	1.56	1.000					
	1 1/4	51.0	15.0	89.0	15.8	2.44	2.37	89.0	15.8	2.44	2.37	1.56	1.000					
	1 1/8	45.0	13.2	79.6	14.0	2.45	2.32	79.6	14.0	2.45	2.32	1.57	1.000					
	1	38.9	11.4	69.7	12.2	2.47	2.28	69.7	12.2	2.47	2.28	1.58	1.000					
	3/4	32.7	9.61	59.4	10.3	2.49	2.23	59.4	10.3	2.49	2.23	1.58	1.000					
	1/2	26.4	7.75	48.6	8.36	2.50	2.21	48.6	8.36	2.50	2.21	1.59	1.000					
L 8 x6 x1	1 1/2	44.2	13.0	80.8	15.1	2.49	2.65	38.8	8.92	1.73	1.65	1.28	0.543					
	1 1/4	39.1	11.5	72.3	13.4	2.51	2.61	34.9	7.94	1.74	1.61	1.28	0.547					
	1 1/8	33.8	9.94	63.4	11.7	2.53	2.56	30.7	6.92	1.76	1.56	1.29	0.551					
	1	28.5	8.36	54.1	9.87	2.54	2.52	26.3	5.88	1.77	1.52	1.29	0.554					
	3/4	25.7	7.56	49.3	8.95	2.55	2.50	24.0	5.34	1.78	1.50	1.30	0.556					
	1/2	20.2	6.75	39.2	7.07	2.57	2.45	19.3	4.79	1.79	1.47	1.30	0.558					
L 8 x4 x1	1 1/2	37.4	11.0	69.6	14.1	2.52	3.05	11.6	3.94	1.03	1.05	0.846	0.247					
	1 1/4	28.7	8.44	54.9	10.9	2.55	2.95	9.36	3.07	1.05	0.953	0.852	0.258					
	1 1/8	21.9	6.43	42.8	8.35	2.58	2.88	7.43	2.38	1.07	0.882	0.861	0.265					
	1	19.6	5.75	38.5	7.49	2.59	2.86	6.74	2.15	1.08	0.859	0.855	0.267					
	3/4	16.3	4.99	31.8	6.54	2.61	2.84	6.05	1.92	1.09	1.01	0.860	0.324					
	1/2	13.6	4.24	26.6	5.69	2.62	2.81	5.36	1.67	1.10	0.963	0.865	0.329					
L 7 x4 x 3/8	1 1/2	26.2	7.69	37.8	8.42	2.22	2.51	9.05	3.03	1.09	1.01	0.860	0.324					
	1 1/4	22.1	6.88	32.4	7.14	2.24	2.46	7.84	2.58	1.10	0.963	0.865	0.329					
	1 1/8	17.9	5.25	26.7	5.81	2.25	2.42	6.53	2.12	1.11	0.917	0.872	0.335					
	1	13.6	3.98	20.6	4.44	2.27	2.37	5.10	1.63	1.13	0.870	0.880	0.340					
	3/4	11.0	3.23	17.9	3.69	2.28	2.36	4.79	1.48	1.14	0.870	0.880	0.340					
	1/2	8.5	2.58	14.2	2.94	2.29	2.35	4.44	1.33	1.15	0.870	0.880	0.340					

Angles in shaded rows may not be readily available. Availability is subject to rolling accuracy and geographical location, and should be checked with material suppliers.

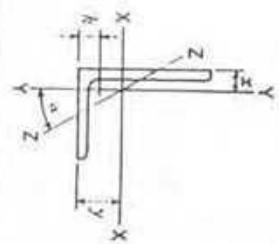

ANGLES  
Equal legs and unequal legs  
Properties for designing

Size and Thickness	k	Weight per foot	Area	AIS X X						AIS Y Y						AIS Z Z		
				I	S	r	y	I	S	r	x	r	Tan α					
L 6 x6 x1	1 1/2	37.4	11.0	35.5	8.57	1.80	1.86	35.5	8.57	1.80	1.86	1.17	1.000					
	1 1/4	33.1	9.73	31.9	7.63	1.81	1.82	31.9	7.63	1.81	1.82	1.17	1.000					
	1 1/8	28.7	8.44	28.2	6.66	1.82	1.78	28.2	6.66	1.83	1.78	1.17	1.000					
	1	24.2	7.11	24.2	5.66	1.84	1.73	24.2	5.66	1.84	1.73	1.18	1.000					
	3/4	19.6	5.75	19.9	4.61	1.86	1.68	19.9	4.61	1.86	1.68	1.18	1.000					
	1/2	15.1	4.36	15.4	3.53	1.88	1.64	15.4	3.53	1.88	1.64	1.19	1.000					
L 6 x4 x 3/8	1 1/2	27.2	7.98	27.7	7.15	1.86	2.12	9.75	3.39	1.11	1.12	0.857	0.421					
	1 1/4	23.6	6.94	24.5	6.25	1.88	2.08	8.68	2.97	1.12	1.08	0.860	0.428					
	1 1/8	20.0	5.86	21.1	5.31	1.90	2.03	7.52	2.54	1.13	1.03	0.864	0.435					
	1	18.1	5.31	19.3	4.83	1.90	2.01	6.91	2.31	1.14	1.01	0.866	0.438					
	3/4	16.2	4.75	17.4	4.33	1.91	1.99	6.27	2.08	1.15	0.987	0.870	0.440					
	1/2	14.3	4.18	15.5	3.83	1.92	1.96	5.60	1.85	1.16	0.964	0.873	0.443					
L 6 x3 1/2 x 1	1 1/2	15.3	4.50	16.6	4.24	1.92	2.08	4.25	1.59	0.972	0.833	0.759	0.344					
	1 1/4	11.7	3.42	12.9	3.24	1.94	2.04	3.34	1.23	0.988	0.787	0.767	0.350					
	1 1/8	9.8	2.87	10.9	2.73	1.95	2.01	2.85	1.04	0.996	0.763	0.772	0.352					
	1	8.5	2.58	10.0	2.42	1.96	2.00	2.58	0.92	0.996	0.763	0.772	0.352					
	3/4	7.2	2.29	9.1	2.13	1.97	1.99	2.35	0.84	0.996	0.763	0.772	0.352					
	1/2	6.0	1.99	8.0	1.80	1.98	1.98	2.10	0.76	0.996	0.763	0.772	0.352					
L 5 x5 x 3/8	1 1/2	27.2	7.98	17.8	5.17	1.49	1.57	17.8	5.17	1.49	1.57	1.000						
	1 1/4	23.6	6.94	15.7	4.53	1.51	1.52	15.7	4.53	1.51	1.52	1.000						
	1 1/8	20.0	5.86	13.6	3.86	1.52	1.48	13.6	3.86	1.52	1.48	0.978	1.000					
	1	16.2	4.75	11.3	3.16	1.54	1.43	11.3	3.16	1.54	1.43	0.983	1.000					
	3/4	14.3	4.18	10.0	2.79	1.55	1.41	10.0	2.79	1.55	1.41	0.986	1.000					
	1/2	12.3	3.61	8.74	2.42	1.56	1.39	8.74	2.42	1.56	1.39	0.990	1.000					

Angles in shaded rows may not be readily available. Availability is subject to rolling accuracy and geographical location, and should be checked with material suppliers.



W SHAPES  
Dimensions

Designation	Area A	Depth d	Web		Flange		Distance			
			Thickness $t_w$	$t_w/2$	Width $b_f$	Thickness $t_f$	T	h	$h_1$	
W14x132	38.8	14.66	14 1/2	0.645	14.725	14 1/2	1.030	11 1/4	1 1/4	13 1/4
x120	35.3	14.48	14 1/2	0.590	14.670	14 1/2	0.940	11 1/4	1 3/8	13 1/8
x109	32.0	14.32	14 1/2	0.525	14.605	14 1/2	0.860	11 1/4	1 3/8	13 1/8
x99	29.1	14.16	14 1/2	0.485	14.565	14 1/2	0.780	11 1/4	1 3/8	13 1/8
x90	26.5	14.02	14	0.440	14.520	14 1/2	0.710	11 1/4	1 3/8	13 1/8
W14x82	24.1	14.31	14 1/4	0.510	10.130	10 1/4	0.855	11	1 1/2	13 1/4
x74	21.8	14.17	14 1/4	0.450	10.070	10 1/4	0.785	11	1 1/2	13 1/4
x68	20.0	14.04	14	0.415	10.035	10	0.720	11	1 1/2	13 1/4
x61	17.9	13.89	13 3/4	0.375	9.995	10	0.645	11	1 1/2	13 1/4
W14x53	15.6	13.92	13 3/4	0.370	8.060	8	0.660	11 1/2	1 1/2	13 1/4
x48	14.1	13.79	13 3/4	0.340	8.030	8	0.595	11	1 3/8	13 1/8
x43	12.6	13.66	13 3/4	0.305	7.995	8	0.530	11 1/2	1 3/8	13 1/8
W14x38	11.2	14.10	14 1/4	0.310	6.770	6 3/4	0.515	12	1 1/2	13 1/4
x34	10.0	13.98	14	0.285	6.745	6 3/4	0.455	12	1 1/2	13 1/4
x30	8.85	13.84	13 3/4	0.270	6.730	6 3/4	0.385	12	1 1/2	13 1/4
W14x26	7.69	13.91	13 3/4	0.255	5.025	5	0.420	12	1 1/2	13 1/4
x22	6.49	13.74	13 3/4	0.230	5.000	5	0.335	12	1 1/2	13 1/4

W SHAPES  
Properties

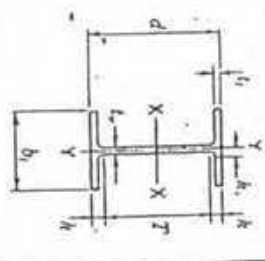

Nom. wt lb	Compact Section Coefficients			$r_T$	$d/A$	Elastic Properties						Torsional Properties		Plastic Modulus	
	$b_f/t_f$	$F_y$	$d/t_w$			$I_x$	$I_y$	$S_x$	$S_y$	$r_x$	$r_y$	$J$	$C_{w1}$	$Z_x$	$Z_y$
132	7.1	22.7	—	4.05	0.97	1530	209	6.28	548	74.5	3.76	12.3	234	113	
120	7.8	24.3	—	4.04	1.05	1380	190	6.24	485	67.5	3.74	9.37	212	102	
109	8.5	27.3	—	4.02	1.14	1240	173	6.22	447	61.2	3.73	7.12	192	92.7	
99	9.3	29.2	—	4.00	1.25	1110	157	6.17	402	55.2	3.71	5.37	173	83.6	
90	10.2	31.9	—	3.99	1.35	999	143	6.14	362	49.9	3.70	4.06	157	75.6	
82	5.9	28.1	—	2.74	1.55	882	123	6.05	148	29.3	2.48	5.08	139	44.8	
74	6.4	31.5	—	2.72	1.79	796	112	6.04	134	26.6	2.48	3.88	126	40.6	
68	7.0	33.8	—	2.71	1.92	723	103	6.01	121	24.2	2.46	3.02	115	36.9	
61	7.7	37.0	—	2.70	2.15	640	92.2	5.98	107	21.5	2.45	2.20	102	32.8	
53	6.1	37.6	46.7	2.15	2.62	541	77.8	5.89	57.7	14.3	1.92	1.94	87.1	22.0	
48	6.7	40.6	40.2	2.13	2.89	485	70.3	5.85	51.4	12.8	1.91	1.46	78.4	19.6	
43	7.5	44.8	32.9	2.12	3.22	428	62.7	5.82	45.2	11.3	1.89	1.05	69.6	17.3	
38	6.6	45.5	31.9	1.77	4.04	385	54.6	5.87	26.7	7.88	1.55	0.80	61.5	12.1	
34	7.4	49.1	27.4	1.76	4.56	340	48.6	5.83	23.3	6.91	1.53	0.57	54.6	10.6	
30	8.7	53.3	25.1	1.74	5.34	291	42.0	5.73	19.6	5.82	1.49	0.38	47.3	8.99	
26	6.0	54.5	22.2	1.28	6.59	245	35.3	5.65	8.91	3.54	1.08	0.36	40.2	5.54	
22	7.5	59.7	18.5	1.25	8.20	199	29.0	5.54	7.00	2.80	1.04	0.21	33.2	4.39	

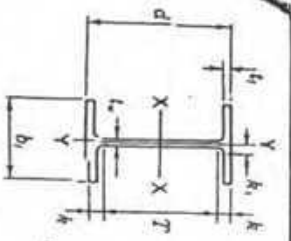

W SHAPES  
Dimensions

Designation	Area A	Depth d	Web		Flange		Distance				
			Thickness $t_w$	$\frac{t_w}{2}$	Width $b_f$	Thickness $t_f$	T	K	K <sub>1</sub>		
	in. <sup>2</sup>	in.	in.	in.	in.	in.	in.	in.	in.	in.	in.
W18x119	35.1	18.97	19	0.655	11.265	1.060	15 1/2	13 3/4	15 1/2	13 3/4	15 1/2
x106	31.1	18.73	18 3/4	0.590	11.200	0.940	15 1/2	13 3/4	15 1/2	13 3/4	15 1/2
x 97	28.5	18.59	18 1/2	0.535	11.145	0.870	15 1/2	13 3/4	15 1/2	13 3/4	15 1/2
x 86	25.3	18.39	18 3/8	0.480	11.090	0.770	15 1/2	13 3/4	15 1/2	13 3/4	15 1/2
x 76	22.3	18.21	18 1/4	0.425	11.035	0.680	15 1/2	13 3/4	15 1/2	13 3/4	15 1/2
W18x 71	20.8	18.47	18 1/2	0.485	7.635	0.810	15 1/2	13 3/4	15 1/2	13 3/4	15 1/2
x 65	19.1	18.35	18 3/8	0.450	7.590	0.750	15 1/2	13 3/4	15 1/2	13 3/4	15 1/2
x 60	17.6	18.24	18 1/4	0.415	7.555	0.695	15 1/2	13 3/4	15 1/2	13 3/4	15 1/2
x 55	16.2	18.11	18 1/8	0.390	7.530	0.630	15 1/2	13 3/4	15 1/2	13 3/4	15 1/2
x 50	14.7	17.99	18	0.355	7.495	0.570	15 1/2	13 3/4	15 1/2	13 3/4	15 1/2
W18x 46	13.5	18.06	18	0.360	6.060	0.605	15 1/2	13 3/4	15 1/2	13 3/4	15 1/2
x 40	11.8	17.90	17 3/4	0.315	6.015	0.525	15 1/2	13 3/4	15 1/2	13 3/4	15 1/2
x 35	10.3	17.70	17 3/4	0.300	6.000	0.425	15 1/2	13 3/4	15 1/2	13 3/4	15 1/2
W16x100	29.4	16.97	17	0.585	10.425	0.985	13 3/8	11 1/4	13 3/8	11 1/4	13 3/8
x 89	26.2	16.75	16 3/4	0.525	10.365	0.875	13 3/8	11 1/4	13 3/8	11 1/4	13 3/8
x 77	22.6	16.52	16 1/2	0.455	10.295	0.760	13 3/8	11 1/4	13 3/8	11 1/4	13 3/8
x 67	19.7	16.33	16 3/8	0.395	10.235	0.665	13 3/8	11 1/4	13 3/8	11 1/4	13 3/8
W16x 57	16.8	16.43	16 3/8	0.430	7.120	0.715	13 3/8	11 1/4	13 3/8	11 1/4	13 3/8
x 50	14.7	16.26	16 1/4	0.380	7.070	0.630	13 3/8	11 1/4	13 3/8	11 1/4	13 3/8
x 45	13.3	16.13	16 1/4	0.345	7.035	0.565	13 3/8	11 1/4	13 3/8	11 1/4	13 3/8
x 40	11.8	16.01	16	0.305	6.995	0.505	13 3/8	11 1/4	13 3/8	11 1/4	13 3/8
x 36	10.6	15.86	15 7/8	0.295	6.985	0.430	13 3/8	11 1/4	13 3/8	11 1/4	13 3/8
W16x 31	9.12	15.88	15 7/8	0.275	5.525	0.440	13 3/8	11 1/4	13 3/8	11 1/4	13 3/8
x 26	7.68	15.69	15 3/4	0.250	5.500	0.345	13 3/8	11 1/4	13 3/8	11 1/4	13 3/8

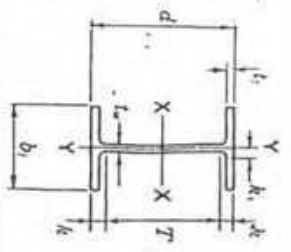

W SHAPES  
Properties

Nominal Wt per ft	Compact Section Criteria	rT	d /A <sub>y</sub>	Elastic Properties				Torsional constant J	Plastic Modulus					
				I	S	r	I		S	Z <sub>x</sub>	Z <sub>y</sub>			
Lb	$\frac{b_f}{2t_f}$ Ksi	$F_y$ Ksi	$\frac{d}{t_w}$ Ksi	in.	in. <sup>4</sup>	in. <sup>3</sup>	in.	in. <sup>4</sup>	in. <sup>3</sup>	in. <sup>3</sup>				
119	5.3	—	29.0	3.02	1.59	2190	231	7.90	253	44.9	2.69	10.6	261	69.1
106	6.0	—	31.7	3.00	1.78	1910	204	7.84	220	39.4	2.66	7.48	230	60.5
97	6.4	—	34.7	2.99	1.92	1750	188	7.82	201	36.1	2.65	5.86	211	55.3
86	7.2	—	38.3	2.97	2.15	1530	166	7.77	175	31.6	2.63	4.10	186	48.4
76	8.1	64.2	42.8	2.95	2.43	1330	146	7.73	152	27.6	2.61	2.83	163	42.2
71	4.7	—	37.3	2.99	2.99	1170	127	7.50	60.3	15.8	1.70	3.48	145	24.7
65	5.1	—	40.8	3.22	3.22	1070	117	7.49	54.8	14.4	1.69	2.73	133	22.5
60	5.4	—	44.0	3.47	3.47	984	108	7.47	50.1	13.3	1.69	2.17	123	20.6
55	6.0	—	46.4	3.82	3.82	890	98.3	7.41	44.9	11.9	1.67	1.66	112	18.5
50	6.6	—	50.7	4.21	4.21	800	88.9	7.38	40.1	10.7	1.65	1.24	101	16.6
46	5.0	—	50.2	4.93	4.93	712	78.8	7.25	22.5	7.43	1.29	1.22	90.7	11.7
40	5.7	—	56.8	5.67	5.67	612	68.4	7.21	19.1	6.35	1.27	0.81	78.4	9.95
35	7.1	—	59.0	6.94	6.94	510	57.6	7.04	15.3	5.12	1.22	0.51	66.5	8.06
100	5.3	—	29.0	2.81	1.65	1490	175	7.10	186	35.7	2.51	7.73	198	54.9
89	5.9	—	31.9	2.79	1.85	1300	155	7.05	163	31.4	2.49	5.45	175	48.1
77	6.8	—	36.3	2.77	2.11	1110	134	7.00	138	26.9	2.47	3.57	150	41.1
67	7.7	—	41.3	2.75	2.40	954	117	6.96	119	23.2	2.46	2.39	130	35.5
57	5.0	—	38.2	3.23	3.23	758	92.2	6.72	43.1	12.1	1.60	2.22	105	18.9
50	5.6	—	42.8	3.65	3.65	659	81.0	6.68	37.2	10.5	1.59	1.52	92.0	16.3
45	6.2	—	46.8	4.06	4.06	566	72.7	6.65	32.8	9.34	1.57	1.11	82.3	14.5
40	6.9	—	52.5	4.53	4.53	518	64.7	6.63	28.9	8.25	1.57	0.79	72.9	12.7
36	8.1	64.0	53.8	5.28	5.28	448	56.5	6.51	24.5	7.00	1.52	0.54	64.0	10.8
31	6.3	—	57.7	6.53	6.53	375	47.2	6.41	12.4	4.49	1.17	0.46	54.0	7.03
26	8.0	—	62.8	8.27	8.27	301	33.4	6.26	9.59	3.49	1.12	0.26	44.2	5.48

92

**The University of Asia Pacific**  
**Department of Civil Engineering**  
**Final Examination Spring 2008**  
**Program: B. Sc. Engineering (Civil)**

Course Title : Structural Engineering X (Concrete Technology)  
 Time: 2.00 Hours

Course Code: CE 425  
 Full Marks: 100

*There are Six Questions. Answer Four Questions including Questions 1 and 2. Questions 1 and 2 are compulsory.*

- 1) Concrete cylinders were exposed to a marine submerged environment for 15 years to determine the chloride ion profile into concrete for a particular mixture proportion of concrete. To measure chloride concentrations at different depths of the specimens, concrete slices were taken accordingly and then powdered. The powdered samples were used to measure chloride concentrations. The test results are summarized below: (30)

Sample Depth (mm)	Amount of Powdered Sample (g)	Amount of Water Used (ml)	Volume of Filtered Water Used for Titration (ml)	Volume of AgNO <sub>3</sub> Solution Used for Titration (ml)
2.5	10	100	2.1	3.8
13	20	100	4.1	5.3
26	20	100	6.3	2.7
39	20	100	9.6	1.2
50	20	100	20.0	1.2

Concentration of AgNO<sub>3</sub> solution used for titration = N/200.

Mixture Proportion of Concrete

W/C	Unit Contents (kg/m <sup>3</sup> )			
	Cement	Water	Sand	Coarse Aggregate
0.5	375	187.5	700	1037.5

- (a) Calculate the chloride concentrations at different depths of the concrete specimens in weight % of cement and kg/m<sup>3</sup> of concrete.  
 (b) Draw the chloride profile.  
 (c) A steel bar was placed at a cover depth of 30 mm. Judge the possibility of corrosion of the steel bar.
- 2) Refer to the following data: (30)  
 Exposure condition = Marine  
 Time of exposure = 15 years  
 Chloride concentration at the surface of concrete = 2 % of cement (weight basis)

Chloride concentration at a depth of 50 mm from the surface after 15 years of exposure = 0.3% of cement (weight basis)

- (a) Determine the apparent diffusion coefficient,
- (b) Draw the chloride profile into concrete after 25 years, and
- (c) Determine the time required to initiate corrosion over a steel bar placed at a distance 30 mm from the surface of concrete.

- 3) (a) The year of construction, cover concrete, and carbonation coefficient of two construction sites are as follows: (8)

Items	Site 1	Site 2
Year of Construction	January 2008	January 2008
Cover Concrete	1 inch	1 inch
Carbonation Coefficient	$0.5 \text{ mm}/\sqrt{\text{year}}$	$2 \text{ mm}/\sqrt{\text{year}}$

Calculate the time necessary for corrosion of steel bars in concrete due to carbonation for both sites. Make comments on the results.

- (b) "Permeability of concrete is a key factor related to durability of concrete" – Explain. (3)
  - (c) Define Class C and Class F fly ash cements. "Class F fly ash has only pozzolanic activity but Class C fly ash cement has both cementitious and pozzolanic activities" – Why? (3)
  - (d) How is the corrosion activity of steel bars in concrete checked? Write the ASTM C876 specifications to judge the corrosion activity of steel bars in concrete. (3)
  - (d) Explain autogeneous shrinkage of concrete. (3)
- 4) Discuss the properties of fresh and hardened concrete made with a cement with the following mineral admixtures: (20)
- (a) Fly Ash,
  - (b) Ground Granulated Blast Furnace Slag (GGBFS),
  - (c) Silica Fume, and
  - (d) Rice Husk Ash.
- 5) (a) How is a steel bar protected against corrosion in concrete? How is this protection lost? (5)
- (b) Explain the corrosion process of steel bars in concrete with anodic and cathodic reactions. (5)
- (c) Discuss the major causes of deterioration of concrete structures in Bangladesh with possible remedies. (10)
- 6) (a) Write the advantages and disadvantages of RMC. (3)
- (b) Why is superplasticizer used in concrete? (2)
- (c) Write short notes on high performance concrete, shotcrete, and no-fines concrete. (6)
- (d) Discuss three non-destructive test methods used for the evaluation of strength of concrete. (6)
- (e) Explain the mechanism of ASR induced deterioration of concrete structures. (3)

TABLE Error Function,  $\operatorname{erf} x = \frac{2}{\sqrt{\pi}} \int_0^x e^{-t^2} dt$

$x$	$\operatorname{Erf}(x)$	$x$	$\operatorname{Erf}(x)$	$x$	$\operatorname{Erf}(x)$
0.00	0.000000	0.68	0.663782	1.36	0.945561
0.02	0.022564	0.70	0.677801	1.38	0.949016
0.04	0.045111	0.72	0.691433	1.40	0.952285
0.06	0.067621	0.74	0.704678	1.42	0.955376
0.08	0.090078	0.76	0.717537	1.44	0.958296
0.10	0.112463	0.78	0.730010	1.46	0.961053
0.12	0.134758	0.80	0.742101	1.48	0.963654
0.14	0.156947	0.82	0.753811	1.50	0.966105
0.16	0.179012	0.84	0.765143	1.52	0.968413
0.18	0.200936	0.86	0.776100	1.54	0.970586
0.20	0.222703	0.88	0.786688	1.56	0.972628
0.22	0.244296	0.90	0.796908	1.58	0.974547
0.24	0.265700	0.92	0.806768	1.60	0.976348
0.26	0.286900	0.94	0.816271	1.62	0.978038
0.28	0.307880	0.96	0.825424	1.64	0.979622
0.30	0.328627	0.98	0.834232	1.66	0.981105
0.32	0.349126	1.00	0.842701	1.68	0.982493
0.34	0.369365	1.02	0.850838	1.70	0.983791
0.36	0.389330	1.04	0.858650	1.72	0.985003
0.38	0.409010	1.06	0.866144	1.74	0.986135
0.40	0.428392	1.08	0.873326	1.76	0.987190
0.42	0.447468	1.10	0.880205	1.78	0.988174
0.44	0.466225	1.12	0.886788	1.80	0.989091
0.46	0.484655	1.14	0.893082	1.82	0.989943
0.48	0.502750	1.16	0.899096	1.84	0.990736
0.50	0.520500	1.18	0.904837	1.86	0.991473
0.52	0.537898	1.20	0.910314	1.88	0.992156
0.54	0.554939	1.22	0.915534	1.90	0.992791
0.56	0.571616	1.24	0.920505	1.92	0.993378
0.58	0.587923	1.26	0.925236	1.94	0.993923
0.60	0.603856	1.28	0.928734	1.96	0.994427
0.62	0.619411	1.30	0.934008	1.98	0.994892
0.64	0.634586	1.32	0.938065	2.00	0.995323
0.66	0.649376	1.34	0.941913	2.02	0.995720

Rational approximation\*:

$$\operatorname{erf} x = 1 - [1 + 0.0705230784x + 0.0422820123x^2 + 0.0092705272x^3 + 0.0001520143x^4 + 0.0002765672x^5 + 0.0000430638x^6]^{-16} + \epsilon$$

$$|\epsilon| \leq 3 \times 10^{-7}$$

\*From C. Hastings, Jr., *Approximations for Digital Computers*, Princeton University Press, Princeton, N.J., 1955.

**The University of Asia Pacific**  
**Department of Civil Engineering**  
**Final Examination Spring 2008**  
**Program: B.Sc. Engineering (Civil)**

Course Title: Environmental Engineering IV      Course Code: CE 433      Credit: 2.00  
Time: 2.00 Hours      Full Marks: 135

---

Answer **ANY THREE** of the following four Questions.

- 1.(a) On particular day, cars are traveling at a speed of 70 km/hr and average distance between cars is 50 m. each car is emitting carbon monoxide (CO) at a rate of 4.6 g/km. Wind speed is 3.2 m/sec perpendicular to the road and the atmosphere is "neutral". Estimate the ground level concentration of CO at 1 km downwind. 15
- (b) Write down the possible alternative sources of water supply (excluding treatment of groundwater) in arsenic affected areas. What are the principal carcinogenic and non-carcinogenic health effects that may result from exposure to arsenic? 10
- (c) Explain the process of formation of  $H_2O-H_2SO_4$  droplets in the atmosphere. Explain how sulfate particles affect visibility. 10
- (d) How does a three-way catalytic converter help reduce emission of pollutants from a car? How air-fuel ratio affects efficiency of a catalytic converter? 10
- 2.(a) A power plant discharges 325 kg of  $SO_2$  per hour through a stack, which has an effective height of 65 meters. The wind velocity at the top of the stack is 6.0 m/sec and the atmosphere is "neutral". Determine ground level  $SO_2$  concentration at 1 km downwind, along the center-line of the plume. 25
- (b) What control devices are available for particulate contaminants from industrial sources? Explain how particulates are removed in a gravitational settling chamber. 10
- (c) Write down the broad categories of arsenic removal technologies from groundwater. Schematically show the removal mechanism of arsenic from water by the "coagulation-adsorption-coprecipitation: technique. 10
- 3.(a) Classify air pollutants according to origin, chemical composition and state of matter. Give at least two examples of each class. 10
- (b) What do you understand by "Thermal  $NO_x$ " and "Fuel  $NO_x$ "? What are the primary anthropogenic sources of  $NO_x$ ? 14  
What do you understand by photochemical smog? What are its principal constituents?
- (c) What is the most likely source of arsenic in groundwater of Bangladesh? Explain how arsenic can be mobilized in the subsurface by the "oxidation" and "reduction" processes? 10

- (d) With respect to internal combustion engines, what do you understand by: (i) stoichiometric ratio, (ii) lean mixture, (iii) rich mixture? Explain the effect of "air-fuel ratio" on emission of CO, HC and NO<sub>x</sub> from a four-stroke engine. Write down the options available for automotive emission control. 11
  
- 4.(a) What do you understand by "unstable" atmosphere? Draw the shapes of "fumigating" and "lofting" plumes and the corresponding temperature structure. Also comment on the pollution potential of each plume. 10
  
- (b) Which regions of Bangladesh have been most severely affected by arsenic contamination of groundwater? What are the principal chemical forms of inorganic arsenic (arsenite and arsenate) in water? Which chemical form is more toxic? 8
  
- (c) What are the major sources of carbon monoxide (CO) in urban areas? Explain how CO affects oxygen carrying capacity of blood. 10
  
- (d) On a global scale, what are the major sources of SO<sub>x</sub> in the atmosphere? Why SO<sub>x</sub> is particularly harmful in dusty atmosphere? Explain. 10
  
- (e) According to ECR-1997, the air quality standard for NO<sub>2</sub> in Bangladesh is 100 µg/m<sup>3</sup>. Express the standard in ppm (at 1 atm and 25° C). 7

**Table: Values of the constants a, c, d and f**

Stability	a	x ≤ 1 km			x ≥ 1 km		
		c	d	f	c	d	f
A	213	440.8	1.941	9.27	459.7	2.094	-9.6
B	156	106.6	1.149	3.3	108.2	1.098	2.0
C	104	61.0	0.911	0	61.0	0.911	0
D	68	33.2	0.725	-1.7	44.5	0.516	-13.0
E	50.5	22.8	0.678	-1.3	55.4	0.305	-34.0
F	34	14.35	0.740	-0.35	62.6	0.180	-48.6

Note: The computed values of σ will be in meters when x is given in kilometers.

10/2

**The University of Asia Pacific**  
**Department of Civil Engineering**  
**Final Examination Spring 2008**  
**Program: B.Sc Engineering (Civil)**

**Course Title: Transportation Engineering II**  
**(Highway Design & Railways)**

**Time: 3.00 Hours**

**Course Code: CE 451**  
**Full Marks: 150**

*There are two sections in the question paper namely "SECTION A" and "SECTION B". You have to answer from both sections according to the instruction mentioned in each section.*

**SECTION A**

*There are **FOUR** questions in this section. Answer any **THREE**.*

1. (a) What is gauge? Why is it desirable to use uniform gauges in a country? (3+7)  
(b) What are the requirements of good ballast? What are the functions of rail? (5+5)  
(c) Why is it necessary to provide the followings: (5)  
(i) Tilting of rail (ii) Geo-textile
  
2. (a) Write a short note on "John Macadam". (5)  
(b) Elaborately explain different type of distresses in rigid and flexible pavement. Also discuss the causes of these distresses and relevant remedial measures. (20)
  
3. (a) What is buckling of rails? What are the disadvantages of coning of wheels? (6.5)  
(b) Establish a relationship between degree of curvature and versine of a curve. (5)  
(c) Discuss the classification of fixed signals. (7.5)  
(d) Write short note on (6)  
    i) Marshalling yard  
    ii) Elastic fastening  
    iii) Vacuum brakes
  
4. (a) Write two important advantages of steel and wooden sleepers. (6)  
(b) Calculate the maximum permissible train load that can be pulled by a locomotive with 3 pairs of driving wheels having an axle load of 23 tones each on a straight level B.G. track at a speed of 75 kmph. Also calculate the reduction in speed if the train has to run on a rising gradient of 1 in 250. What would be the further reduction in speed if the train has to negotiate a  $4^\circ$  curve on the rising gradient? Assume coefficient of friction as 0.2. (13)  
(c) Give the reasons for followings (6)  
    i) The dog-spikes should be driven in a staggered manner  
    ii) The gradients on curves are reduced

**SECTION B**

*There are **FOUR** questions in this section. Answer any **THREE**.*

5. (a) Why Expansion joints are provided in a concrete pavement? (7)  
(b) How do you adjust the mix if stability, flow or voids in the mixture would not match in the Marshal Method of mix design? (6)  
(c) Show the components of flexible and concrete pavement. (6)  
(d) Write a short note on Low Cost Road. (6)

6. (a) Draw a typical doweled expansion joint. (6)  
 (b) What are the most important properties of aggregate for highway construction? List the laboratory tests, in different groups, of bituminous materials used in road construction. (8)  
 (c) For the following data, design and draw the distributed reinforcement and tie bars for a rigid pavement: (11)
- Thickness of the rigid pavement = 9 inch  
 Lane width = 11 ft, two lane  
 Spacing of the transverse joint = 42 ft  
 Allowable stress of steel = 20000 psi  
 Compressive strength of concrete = 3650 psi,  $f = 1.5$
7. (a) What are the pavement and traffic variations adopted in AASHO road test? (8)  
 (b) Explain the process of determining optimum asphalt content from the plots (draw qualitative curves) prepared after testing samples in Marshall Method of Mix Design. (9)  
 (c) Write down the purpose, materials and construction methods of prime coat & seal coat. (8)
8. (a) What do you mean by "pumping of joints"? How does pumping occur in rigid pavement? How can we prevent pumping action? (9)  
 (b) What is cutback asphalt? (3)  
 (c) For the thickness design of a concrete pavement for a two lane national highway, the following information are available. (13)  
 Current two-lane ADT = 1008, ADT = 50%  
 For a design period of ten years and 8% growth rate, the traffic projection factor is 14.5  
 Percentage of trucks using the design lane is 75  
 Combined sub grade and sub base,  $k = 130$  psi  
 Modulus of rupture for concrete = 650 psi  
 Load safety factor = 1.2

The design engineer is assumed a thickness of 9.5 inch and found the data tabulated below. Check whether the assumed thickness is safe or not by using the table. Assume reasonable value for missing data, if any.

Axle load, kips		No. of axle per 1000 trucks	Allowable repetitions for fatigue analysis	Allowable repetitions for erosion analysis
Single axle	30	0.36	27,000	1500,000
	28	0.73	77,000	2200,000
	26	1.5	230,000	3500,000
	24	3.22	1200,000	11000,000
	22	5.34	Unlimited	Unlimited
	20	9.11	Unlimited	Unlimited
Tandem Axle	52	1.27	Unlimited	920,000
	48	2.6	Unlimited	1500,000
	44	6.55	Unlimited	2500,000
	40	18.65	Unlimited	4600,000
	36	44.29	Unlimited	9500,000
	32	50.55	Unlimited	Unlimited

**The University of Asia Pacific**  
**Department of Civil Engineering**  
**Final Examination, Spring 2008**  
**Program: B.Sc Engineering (Civil)**

Course Title: Irrigation and Flood Control; Course Code.: CE 461;  
Time: 3 hours

Credit hrs: 3  
Full Marks: 150

**Answer question no. 1 and any FIVE from the rest**  
(Assume any reasonable data if not given)

1. (a) Explain the following (any Four) (10)
- i) Economical section of a canal
  - ii) Optimum utilization of irrigation water and net irrigation requirement
  - iii) Water distribution efficiency and water use efficiency
  - iv) Alignment of canals
  - v) Importance of a Berm
  - vi) Launching apron
- (b) Distinguish between the following (any Four) (10)
- i) Surface and sub-surface irrigation
  - ii) Weir and Barrage
  - iii) Aqueduct and siphon aqueduct
  - iv) Ogee and drop spillways
  - v) Super passage and siphon super passage
  - vi) Level crossing and 'inlet and outlet'
- (c) Determine the time required to irrigate a strip of land of 0.04 ha in area from a tube well with a discharge of 0.02 cumec. The infiltration capacity of the soil is 5 cm/h and the average depth of flow on the field is 10 cm. Find also the maximum area that can be irrigated from this tube well. (5)
2. (a) What is meant by 'Duty of water'? Explain the influence of several factors, which affect duty. (10)
- (b) Water is released at the rate of 5 cumecs at the head sluice. If the duty at the field is 100 ha/cumec and the loss of water in transit is 30%. Find the area of the land that can be irrigated. (5)
- (c) Find out the capacity of a reservoir from the following data. The cultivable command area is 80,000 hectares. (10)

Crop	Base in days	Duty in hec/cumec	Irrigation Intensity(%)
Rice	120	1800	25
Wheat	120	2000	30
Sugarcane	320	2500	20

Assume the canal and reservoir losses as 5% and 10% respectively.

- 79
3. (a) Explain in details, how will you proceed for determining the approximate design discharge of an irrigation project. (12)

(b) The cultivable commanded area of a watercourse is 1200 hectares. Intensities of sugarcane and wheat crops are 20% and 40% respectively. The duties for the crops at the head of the watercourse are 730 hectares/cumec and 1800 hectares/cumec respectively. Find the discharge required at the head of the watercourse. (13)

4. (a) Why should lining be provided in canals? How will you justify economically the necessity of lining an existing canal? (10)

(b) A canal of length 5 km and of discharge capacity 3.5 cumec is proposed to be lined with boulder lining. The total cost of lining is estimated as 4 lakhs. The life of lining is considered as 60 years. Justify the lining in the canal from the following data. (10)

Rate of interest	= 8 %
Seepage loss	= 2 %
Revenue for irrigation water	= Tk. 75 per hect-m
Maintenance cost per Km for lined canal	= Tk. 1000
Maintenance cost per Km for unlined canal	= Tk. 2500
Base period of crop	= 120 days
Additional benefit/Km	= Tk. 1000

(c) What is 'piping' in a hydraulic structure? What are the ill effects of piping and how to avoid these effects? (5)

5. (a) What are the causes of failure of a hydraulic structure and how to prevent them? Name the different parts of the barrage. (6)

(b) Sketch a typical layout plan of a head works and its components. (5)

(c) Using Khosla's curves, determine the following for the apron shown below:

(i) If percentage of pressure at C2 is 56% what will be the percentage of pressure at this point after corrections due to pile interference and slope

(ii) Find exit gradient where, correction factor for slope, 3:1 = 4.5, assume floor thickness = 1 m. (14)

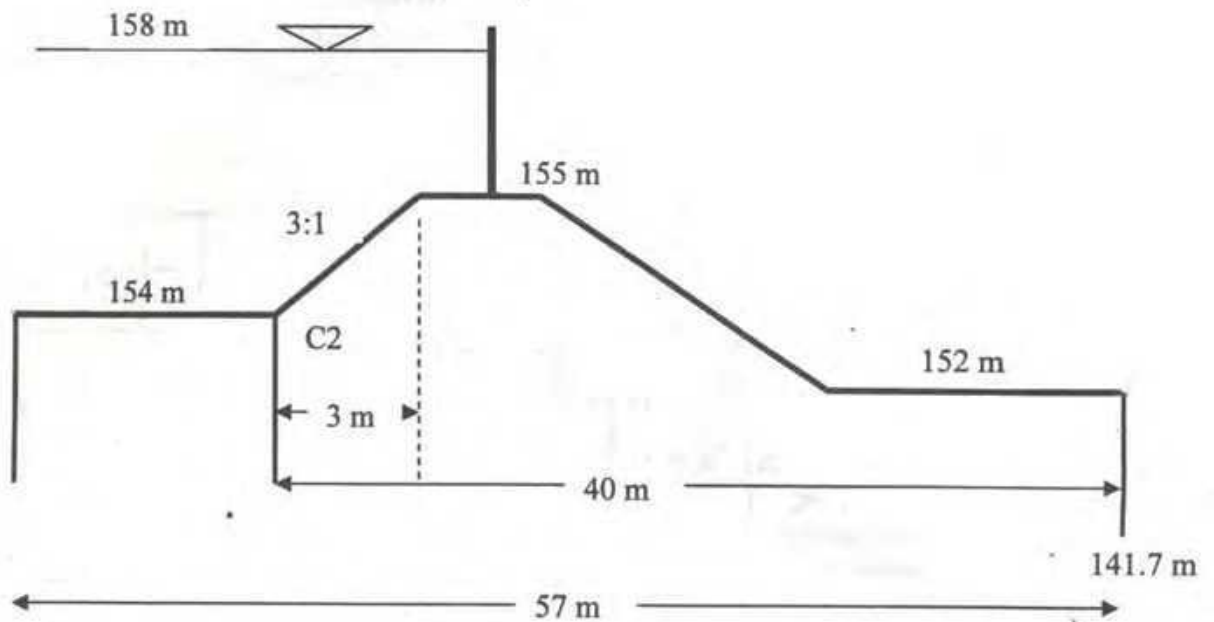

6. (a) Describe flood management approaches. What are the possible river training works you may propose in case of human intervention in a natural stream? (10+7=17)
- (b) Describe the necessity of river training works. Distinguish between Spur and Hard point. (5+3=8)
7. (a) Distinguish between streamline and equipotential lines. How does Lane's theory differ from Bligh's creep length theory? (8)
- (b) What is waterlogging? State the effects of water logging. (4+5=9)
- (c) What is a canal fall? Describe an ogee fall and rapid fall with sketch. (2+6=8)
8. (a) Describe the working principle of centrifugal pump. How do you determine the 'Horse Power' of a pump? (10)
- (b) Why spillways are provided in a dam? (5)
- (b) What is meant by the frequency of irrigation and how do you ascertain it? (10)

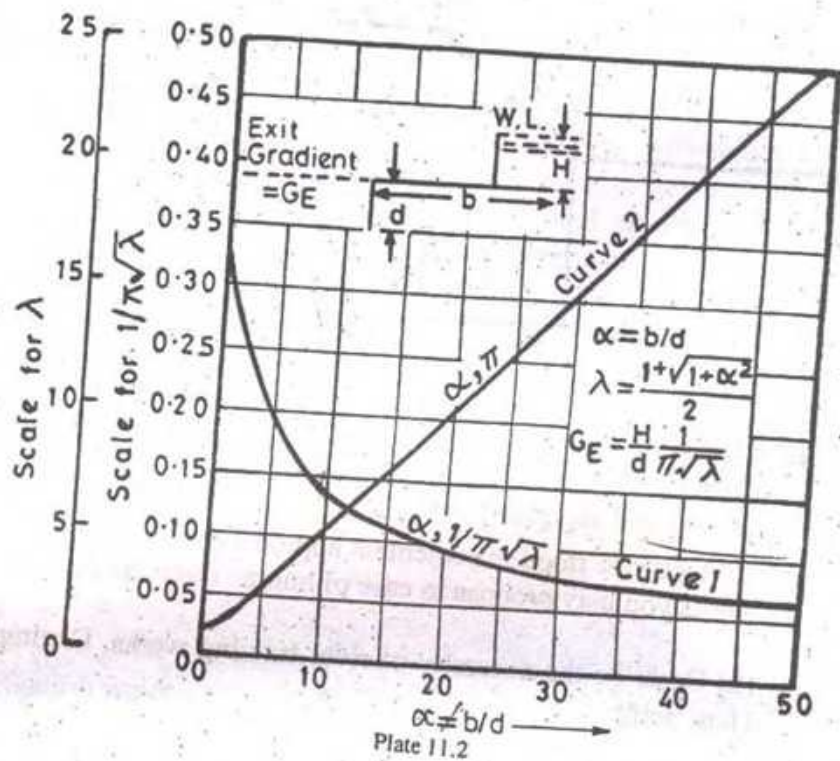

102

**The University of Asia Pacific**  
**Department of Civil Engineering**  
**Final Examination Spring- 2008**  
**Program: B.Sc. Engineering (Civil)**

Course Title: Environmental Engineering VIII    Course Code: CE 531    Credit: 2.00  
(GIS and Remote Sensing)

Time: 2 hours

Full Marks: 50

---

Answer all questions. Each question carries equal marks. Use ArcView software to solve these problems. Use "Spring\_08" data folder.

---

$$6 + 3 + 4 + 4 + 3 = 20$$

1. a. You have a shape file 'uttara.shp' representing a sector in Uttara (Each polygon represents a holding, thus there are 5257 holdings). You have also a map Poles.shp representing the position of electric poles (there are 1775 poles). DESA divided their electric poles into four zones, namely zone 1, zone 2, zone 3, and zone 25 for daily load shedding management. In the map, zones are represented in "ID" column of pole.shp map. If DESA impose load-shedding everyday as per the following schedule:

Time	Zone
7.00 pm – 8.00 pm	1
8.00 pm – 9.00 pm	2
9.00 pm – 10.00 pm	3
10.00 pm – 11.00 pm	25

Find out, (a) How many holdings will be affected during load shedding at zone 1?

(b) How many holdings will be affected during load shedding at zone 2?

(c) How many holdings will be affected during load shedding at zone 3?

(d) How many holdings will be affected during load shedding at zone 25?

Assume, rest of the holdings has no electric line (vacant plot)

- b. There are three community centres at Uttara area namely, (i) Uttara community centre (ii) Istikutum community centre and (iii) aponjon community centre. The location of the community centres are given in the map 'centres.shp'. Find out the number of holdings situated within a distance of 200 unit from each community centre.

- c. The path of rail line in Dhaka city is given in the shape file line.shp. The Dhaka metropolitan map is also given in dhaka\_1.shp. Add these two theme maps into your view. Find out the total number of wards and ward number that crosses the rail line.
- d. The sector map utara is given in 'sec.shp' and the location of various branches of banks in the sectors is shown in banks.shp. Add these two theme maps into your view. Find out how many branches of banks are in Sector 1, 4, 7, and 9 respectively
- e. Dhaka metropolitan map is given in Dhaka\_1.shp. What is the area in square km of ward no 1 and 49. What is the total area of Dhaka city.

$$2+2+2+7+2=15$$

2. Dhaka metropolitan map is given in Dhaka\_1.shp. There are 91 wards in Dhaka city. X is a super shop which operates 168 branches in 91 wards. Location and daily sales volume (Newfield1) is given in shop.shp. Find,
- Which ward generates highest revenue
  - Which ward generates lowest revenue
  - What is the total sum of sales volume
  - Create a map based on sales volume by symbolizing sales data.  
(use color schemes as "Green Monochromatic")
  - Prepare a layout showing the sales volume.

$$3+5+3+2+2=15$$

3. a. There are 20 thanas (add thana.shp) in Dhaka city. Create a new theme map as per the following figure and save as lake.shp.

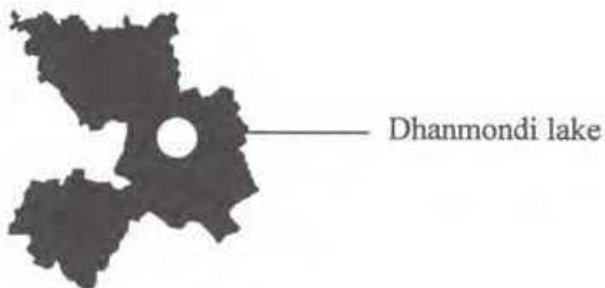

- b. Add **district.shp** in your view. There are six airports in Bangladesh. They are situated in Dhaka, Chittagang, Sylhet, Jessore, Barisal, Rajshahi Zilla. Create a point theme map showing the six airports and add attributes as follows:

Shape	Airport	Status
Point	Dhaka	International
Point	Chittagang	International
Point	Sylhet	International
Point	Jessore	Domestic
Point	Barisal	Domestic
Point	Rajshahi	Domestic

Save the newly created point theme map as '**airport.shp**'.

- c. Add **district.shp** in your view. A highway is proposed from **Dhaka** to **Sylhet** city..Create a line theme map and save it as **highway.shp** and add attributes as follows:

Shape	Highway	Length(km)
Line	Dhaka-Sylhet	350

- d. Dhaka is expanding every year (add **thana.shp** in your view) The area shown was five yeas earlier. RAJUK wants to acquire new lands to develop a model town. Create a new map with the help of existing map. The figures are shown below,

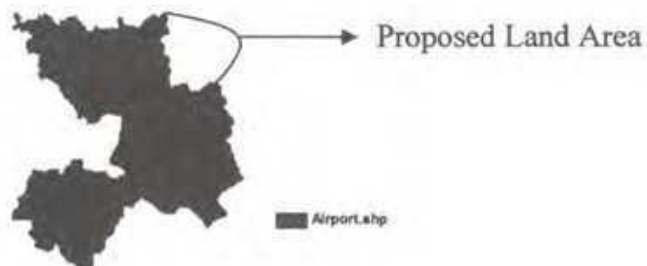

Save the newly created theme map as '**new\_dhaka.shp**'.

- e. Add thana\_\_1.shp in your view. Find out the name of the upozilla whose area is greater than 1800 sqkm.

THE UNIVERSITY OF ASIA PACIFIC  
DEPARTMENT OF CIVIL ENGINEERING  
Final Examination Spring 2008

Chem – 111  
Full Marks : 50

Course Title : Chemistry  
Time : 3 hours

There are **SEVEN** questions. Answer any **FIVE**.

- Q.1. a) What are Colligative properties of dilute solutions? Name them. Why are they so called? (3)  
b) Deduce an expression relating the molecular weight of a solute with the lowering of vapour pressure of a dilute solution. (4)  
c) 36.4gm of urea is dissolved in 200gm of water at 50°C. The lowering of vapour pressure is 5mm of Hg. Calculate the molecular weight of urea when the vapour pressure of water at 50°C is 92mm of Hg. (3)
- Q.2. a) Explain the following terms with suitable examples: (4)  
(i) Order and Molecularity  
(ii) Rate and Rate constant of a reaction  
b) Derive the integrated rate equation for the First Order Reaction  $A \longrightarrow P$  and prove that a First Order Reaction is never complete. (4)  
c) Discuss two methods for the determination of order of a reaction. (2)
- Q.3. a) State the postulates of Bohr's atomic model and mention its limitations. (4)  
b) Derive the mathematical expression for the calculation of the radius of any orbit in hydrogen atom. (4)  
c) What do you understand by the terms absorption and emission spectra? (2)
- Q.4. a) Find out the relationship between "K<sub>p</sub>" and "K<sub>c</sub>" for the reaction  
$$xA(g) + yB(g) \leftrightarrow mC(g) + nD(g)$$
 (4)  
b) State Le-Chatelier's principle. Discuss briefly the effect of pressure and temperature change on the equilibrium constant of a reaction. (4)  
c) For the reaction  $2NO(g) + Cl_2(g) \leftrightarrow 2NOCl(g)$  the value of "K<sub>p</sub>" at 20°C is  $1.98 \times 10^3 \text{ atm}^{-1}$ . Calculate the value of "K<sub>c</sub>" at the same temperature. (2)
- Q.5. a) What are colloids? Define the terms Sols, Gel and Emulsion. (4)  
b) What are the differences between lyophilic and lyophobic sols? (4)  
c) Discuss one of the methods for the purification of Sols. (2)
- Q.6. a) What do you understand by hardness of water? How is hardness classified? Discuss two methods used for making hard water soft. (4)  
b) What do you mean by water pollution? Define the terms BOD, COD and DO. (4)  
c) How can you define corrosion? Discuss briefly underwater corrosion. (2)
- Q.7. Write notes on the following : (2.5x4= 10)  
(i) Addition polymerization  
(ii) Hess's law of constant heat summation  
(iii) Quantum Numbers  
(iv) Heat of formation and standard heat of formation

39

**The University of Asia Pacific**  
**Final Examination, Spring-2008**  
**Course Title: Bangladesh Studies: History of Bengal**  
**Course No- HSS 111(b), HSS 211 (b)**  
**Department of BBA, CSE, CE, EEE & Pharmacy**  
**Credit: 2.00**

**Full Marks: 50**

**Time:2hrs.**

**Answer any five of the following questions:**

**10x5=50**

1. Narrate the conquest of Nadia by Iktiyaruddin Muhammad Bakhtiyar Khalji.
2. Write the glorious contributions of the Sultanate period.
3. Who were the Baro Bhuiyans? Describe their resistance against the Mughals.
4. Give an account of the Faraiji Movement.
5. Briefly discuss the religious and social reforms of Raja Ram Mohan Roy.
6. Discuss the background and activities of the Mohammedan Literary Society.
7. What were the main objectives of the Six points programme? Illustrate the Six points.

**The University of Asia-Pacific**  
**Department of Architecture, B.B.A**  
**CE, CSE, EEE, Pharmacy**  
**Semester Final Examination Spring-2008**

Course Title : Bangladesh Studies Society and Culture Course Code :  
HSSIII/A/HSS211

Credit : 2.00

Time : 2 Hours.

Full Marks : 50

There are seven questions. Answer any five.

10 X 5 = 50

1. Define Society. What are the essential features of human society ?
2. No society is classless or unstratified (Davis). Examine the statement. Distinguish between class and caste.
3. Discuss the stratification pattern of rural Bangladesh according to "land" and "power".
4. What is family ? Discuss with examples the different types of family. Do you notice any change in the traditional functions of family. Explain
5. "The nature of Third-world urbanization is over-urbanization" (Gerald Breese). Explain the comment.
6. Discuss on any two methods of Sociological research. Which method(s) is/are appropriate to study the traditional societies of Bangladesh.
7. Write short notes on :-
  - (a) Community
  - (b) Institution
  - (c) Association

**The University of Asia Pacific**  
**Department of Civil Engineering**  
**Final Examination, Spring-2008**

Course # IMG-301

Course Title: Principles of Management

Full Marks- 100

Time: 2 hour

Answer any 5(five) of the following questions. All questions are of equal value.

01. How would you define "Management". How do the required managerial skills differ in the organizational hierarchy? What are the differences between productivity, effectiveness and efficiency.
02. Define objectives. Discuss the relationship between objectives and the organizational hierarchy. Describe MBO process.
03. What is decision making? Briefly discuss the process of decision making. State different approaches for selecting an alternative.
04. What do you mean by formal and informal organization? Briefly discuss line and staff functions. How authority is delegated and what are the processes of delegation?
05. What is Motivation? State briefly Maslow's theory of motivation. Discuss the main steps of motivation.
06. What is meant by controlling? Discuss the basic control process. State different types of budgetary and non-budgetary control devices.
07. Write short note on any four of the following:  
(a) HRM (b) Ethics in Business (c) Leadership (d) Time Management (e) MIS

**The University of Asia Pacific**  
**Department of Interdepartmental courses**  
**Final Examination' Spring '2008**  
**Program: B.Sc Engineering (CE)**

Course Title: Math-III  
 Time: 3 Hours

Course Code: MTH-201

Credit: 3.00  
 Full Marks: 50

**Group-A**

**Answer any Two (2) of the following :**

**20**

**Q.1**

(a) Solve the differential equation:  $\log\left(\frac{dy}{dx}\right) = ax + by$ .

(b) Solve:  $(D^2 + D)y = 0$

(c) Solve:  $\cos^2 x \frac{dy}{dx} + y = \tan x$

**Q.2**

(a) Solve the differential equation  $(6x - 5y + 4)dy + (y - 2x - 1)dx = 0$

(b) Solve:  $(D^2 + 1)y = \cos x$ .

(c) Solve:  $(D + 3)^2 y = 25e^{2x}$ .

**Q.3**

(a) Solve:  $\frac{d^2 y}{dx^2} + y = \operatorname{cosec} x$  (by using the variation of parameter).

(b) Find the differential equation from the relation  $x = a \cos t + b \sin t$  where a and b being arbitrary constants.

**Group-B**

**Answer any Four (4) of the following (including Q.4):**

**30**

**Q.4.**

(a) Determine the values k such that the system in unknowns x, y, and z has:

(i) a unique solution (ii) no solution. (iii) more than one solution:

$$kx + y + z = 1$$

$$x + ky + z = 1$$

$$x + y + kz = 1$$

(b) Define the linear combination. Write the vector  $v = (1, -2, 5)$  as a linear combination of the vectors  $e_1 = (1, 1, 1)$ ,  $e_2 = (1, 2, 3)$  and  $e_3 = (2, -1, 1)$ .

24  
Q.5

- (a) Define linear mapping. Show that the mapping  $F$  is linear where  $F(x, y) = (x + y, x)$ .
- (b) Find a basis and dimension of (i) its image  $U$  and (ii) its kernel  $W$  for the linear mapping  $F: \mathbb{R}^3 \rightarrow \mathbb{R}^3$  defined by  $F(x, y, z) = (x + 2y - z, y + z, x + y - 2z)$ .

Q.6

- (a) Consider the bases of  $\mathbb{R}^2: \{e_1 = (1, 0), e_2 = (0, 1)\}$  and  $\{f_1 = (1, 2), f_2 = (2, 3)\}$ . Find the transition matrices  $P$  and  $Q$  from  $\{e_i\}$  to  $\{f_i\}$  and from  $\{f_i\}$  to  $\{e_i\}$  respectively. Verify that  $Q = P^{-1}$ .
- (b) Show that  $[v]_e = P[v]_f$ .

Q.7

Define Eigenvalue and eigenvector. Find all eigenvalues of  $A$  and

the corresponding eigenvectors where  $A = \begin{pmatrix} 4 & 2 \\ 3 & 3 \end{pmatrix}$ . Find an invertible matrix  $P$  such that  $P^{-1}AP$ .

Q.8

- (a) State and Prove Cayley-Hamilton theorem. Find the inverse of  $A$  (using by C-H theorem) where  $A = \begin{pmatrix} 1 & 2 \\ 3 & 7 \end{pmatrix}$ .
- (b) Find the minimum polynomial  $m(t)$  of the matrix  $A$  where :

$$A = \begin{pmatrix} 2 & 1 & 0 & 0 \\ 0 & 2 & 0 & 0 \\ 0 & 0 & 1 & 1 \\ 0 & 0 & -2 & 4 \end{pmatrix}$$