

University of Asia Pacific

Mid Term Examination

Department of Civil Engineering

Course Name: Principle of Accounting Course Code: ACN 301

Time: 1 Hour

Full Marks: 20

Answer all the Questions

1. "Significant amount may be immaterial and insignificant amount may be material for investing decision" Explain with example. 2.5
2. State the basic Accounting Equation and explain the meaning of each term. 2.5
3. The Thayer Model opened for business on May1, 2012. Its trial balance before adjustment on May, 31 is as follows 6

Thayer Model  
Trial Balance  
May 31, 2012

Accounts Name	Debit	Credit
Cash	2,500	
Supplies	1,900	
Prepaid Insurance	2,400	
Land	15,000	
Lodge	70,000	
Furniture	16,800	
Accounts Payable		5,300
Unearned Rent		3,600
Mortgage Payable		35,000
Capital		60,000
Rent Revenue		9,200
Advertising Supplies	500	
Salaries Expense	3,000	
Utility Expense	1,000	
Total	113,100	113,100

Other Data:

- a. Insurance expires at the rate of 200 per month.
- b. A count of supplies shows 900 of unused supplies on May 31.
- c. Annual depreciation is 2400 on the lodge and 3000 on furniture.
- d. The mortgage interest rate is 12%. (The mortgage was taken out on May 1)
- e. Unused rent of 2500 has been earned.

f. Salaries of 800 are accrued and unpaid at May 31.

**Requirement: Make adjusting entry of the following transactions.**

4. Kara Shin is a licensed CPA. During the first month of operations of her business, the following events and transactions occurred (10\*.5=5)

May 1 Shin invested 20000 cash.

2 Purchases 1500 of supplies on account from Read Supply Company.

3 Hired a secretary receptionist at a salary of 1000 per month.

4 Paid office rent of 900 cash for the month.

7 Completed a tax assignment and billed client 2100 for service provided.

12 Received 3500 advance on a management consulting engagement.

17 Received cash of 1200 for service completed for H. Arnold.

31 Paid secretary receptionist 1000 salary for the month.

31 Paid 40% of balance due Read Supply Company.

31 One half of the service has been provided (Related to May 12)

5. **Make a Trial Balance from the following transaction :**

4

Cash 6485, Accounts Receivable 885, Prepaid Rental 900, Land 10000, Building 8000,  
Equipment 6000, Accounts Payable 2000, Mortgage Payable 6000, Capital 20000, Admission  
Revenue 7000, Concession Revenue 170, Advertising Expense 300, Rental expense 1000,  
Salaries expense 1600.

**University of Asia Pacific**  
**Department of Civil Engineering**  
**Mid Examination Spring 2012**

Course Title: Engineering Mechanics I  
 Time: 1 hours

Credit Hours: 3.0

Course Code: CE 101  
 Full Marks: 60 (=3 × 20)

[Answer any 3 (Three) of the following 4 (Four) questions]

1. Determine weight of the sphere A to keep the system in equilibrium. [Given, wt. of sphere B & C = 100 N]

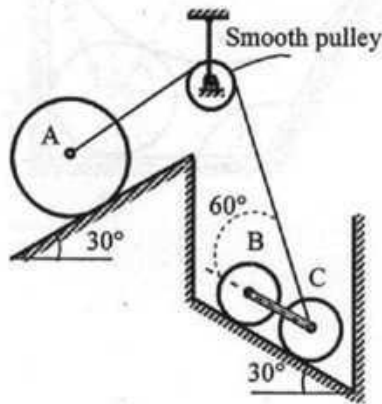

2. In the figure below, find W and F so that the cable AB remains horizontal.

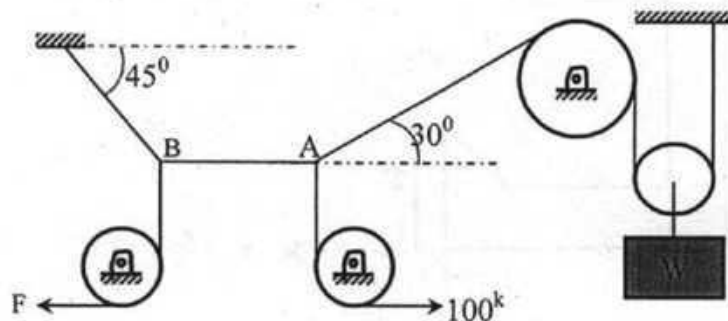

3. Two spheres 1 and 2 are at rest (in equilibrium) against smooth surfaces (frictionless) as shown in the figure below.  $W_1 = 3200$  lb,  $W_2 = 400$  lb,  $F = 1000$  lb and body contact force between sphere 1 and 2 is  $3272$  lb at a direction towards the spheres (i.e. centers of the spheres). Find the reactions at A, B and C and also find out angle  $\theta$ .

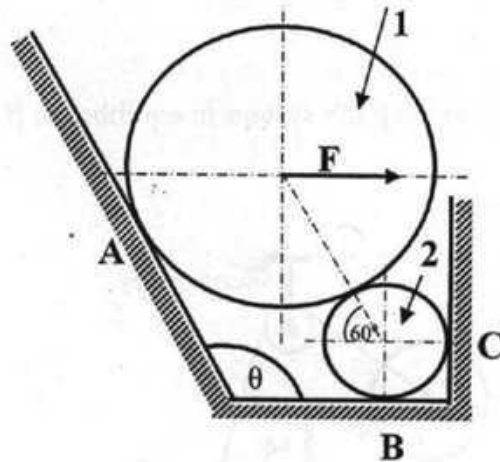

4. Find the centroids of the following shape.

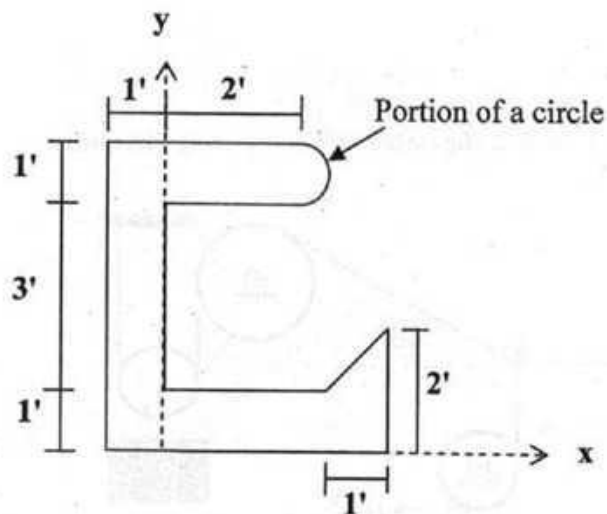

**University of Asia Pacific**  
**Department of Civil Engineering**  
**Mid Semester Examination Spring 2012**

Course # CE 101  
Full Marks: 30

Course Title: Engineering Mechanics I  
Time: 1 hr

There are FOUR questions. Answer any **THREE**.  
Each question carries equal number.

1. In the figure below, the resultant of the forces  $F_1$ ,  $F_2$ ,  $F_3$  and  $F_4$  is 1500 lbs, which acts vertically upwards. Calculate the magnitudes of  $F_3$  and  $\theta$ .

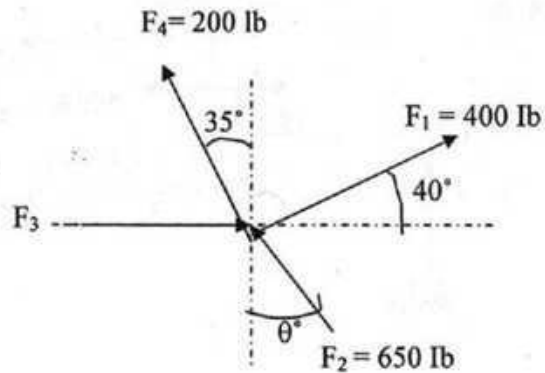

2. Calculate the magnitude of the load  $Q$  for the system in equilibrium shown in the figure below. Given : weight of A is  $2^k$ , weight of B is  $0.5^k$ , weight of C is  $2.5^k$ .

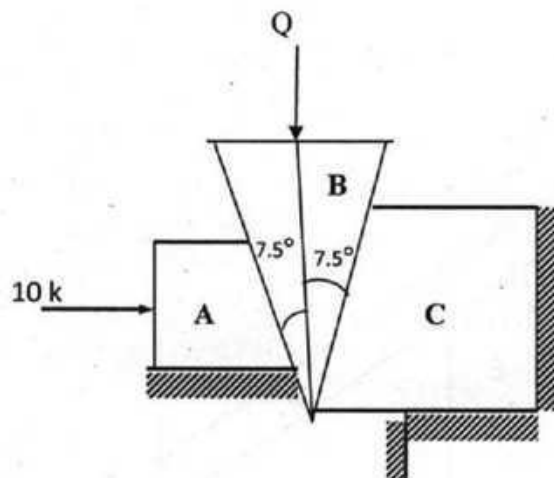

3. Find the coordinate of the foot of the perpendicular drawn from the origin to the resultant of the following force system.

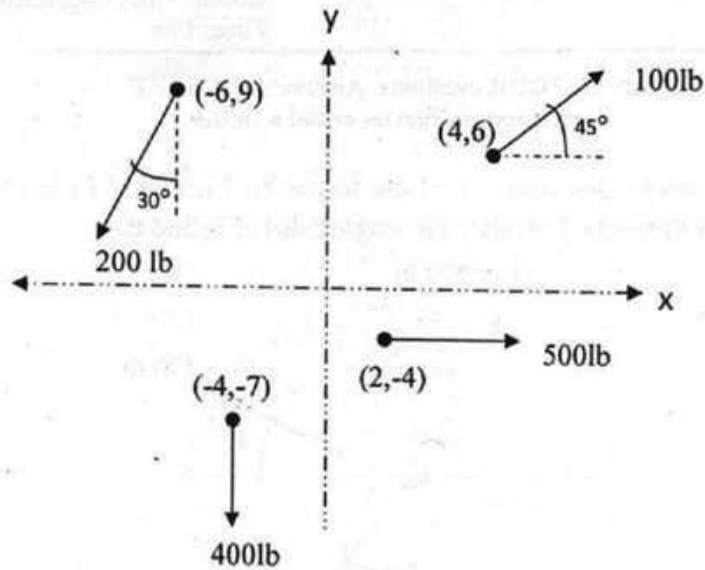

4. A 6" long stirrer AB rests in a measuring flux C having a diameter of 2.5" as shown in the following figure. Calculate the reaction at point A & E and the angle  $\theta$ . Weight of AB=8 oz.

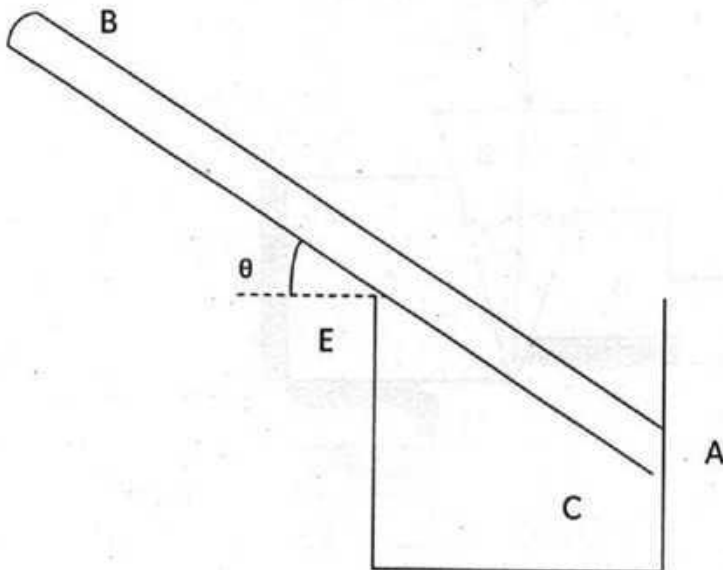

**University of Asia Pacific**  
**Department of Civil Engineering**  
**Mid Semester Examination, Spring 2012**  
**Program: B. Sc. Engineering (Civil)**

Course Title: Engineering Mechanics II  
 Time: 1 hour

Credit Hours: 3.0

Course Code: CE 103  
 Full Marks: 40 (= 4 × 10)

[Answer any 4 (Four) of the following 5 (Five) questions]

1. Each block weighs **200 lb**. Between all of the contacting surfaces,  $f_s = 0.1$ . What is the largest force **F** that can be applied without causing block **B** to slip upward?

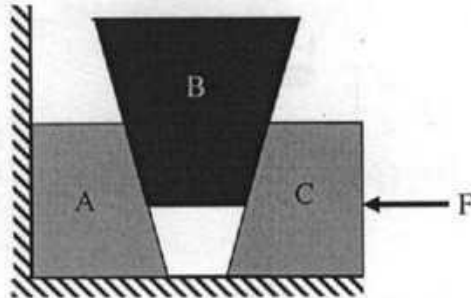

2. A steel wedge is being inserted into a cylindrical shaped wood with the force  $Q = 100\#$ . Determine plane reactions if  $f_s = 1/3$  for all surface. Neglect the weight of wedge.

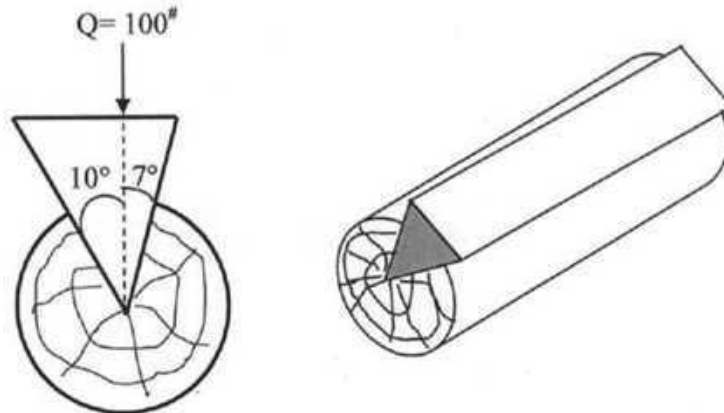

3. If **A** moves **80 ft** from rest down the incline plane in **12 sec**, what is the weight of the body **B** and how far will **B** travel in first **12 sec**? What are the forces on the cable attached to **A** and **B**? Consider all pulleys to be considered frictionless and weightless.

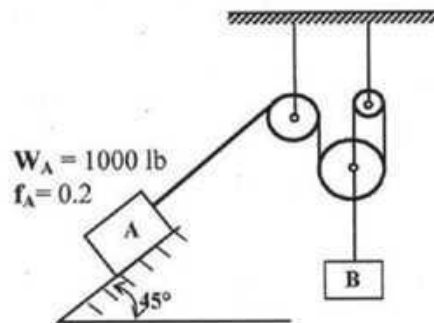

4. A point  $Q$  moves along a circular path whose equation is  $x^2 + y^2 = 64$ . The  $y$  component of the velocity is constant at  $v_y = 10$  fps, at the instant when  $P$  is at the position  $(7, \sqrt{15})$ . What is the tangential speed? What are the components of acceleration along  $x$  and  $y$  direction? If the radius of the circular path is  $8''$ , what is the normal acceleration of the particle?
5. What is the moment of inertia of the pendulum about an axis perpendicular to the page and passing through point  $O$ ?

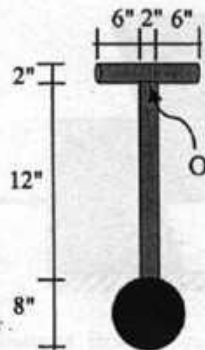

$M_{\text{sphere}} = 6$  lb  
 $M_{\text{cylindrical rod}} = 2$  lb/in

**University of Asia Pacific**  
**Department of Civil Engineering**  
**Mid Semester Examination Spring 2012 (Set B)**

Course #: CE 103  
 Full Marks: 40 (= 4 × 10)

Course Title: Engineering Mechanics II  
 Time: 1 hour

1. The figure below shows a weightless rigid member CDE kept in equilibrium by weights A and B wrapped around pulleys by cables attached to C and D. If the weight of B is 50 lb, calculate the required weight of A and corresponding reaction at support E to keep the motion of B impending (i) upwards, (ii) downwards [Given: Friction factor ( $f_s$ ) at both pulleys = 0.30].

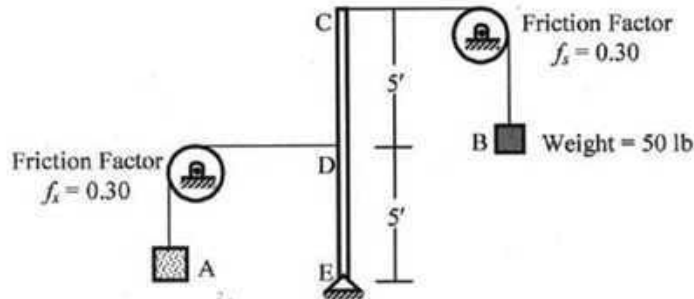

2. Calculate the mass moment of inertia ( $I_x$ ) and radius of gyration ( $k_x$ ) about the x-axis of the glass of water shown below [Given: Density of glass = 3.1 slug/ft<sup>3</sup>, Density of water = 1.9 slug/ft<sup>3</sup>].

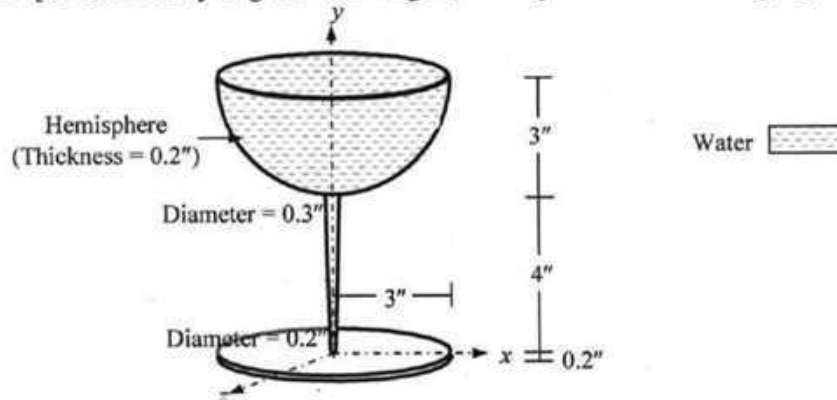

3. A roller skater moves along the curved path AB shown below with a constant horizontal velocity ( $v_x = 30$  ft/sec) but variable vertical velocity ( $v_y$ ). Upon reaching the point B, he moves freely under gravity and hits the ground at point C. Calculate the (i) Height ( $h_B$ ), magnitude ( $v$ ) and angle ( $\theta$ ) of his velocity at B (ii) Maximum height ( $y_{max}$ ) and distance ( $S$ ) he reaches before hitting the ground.

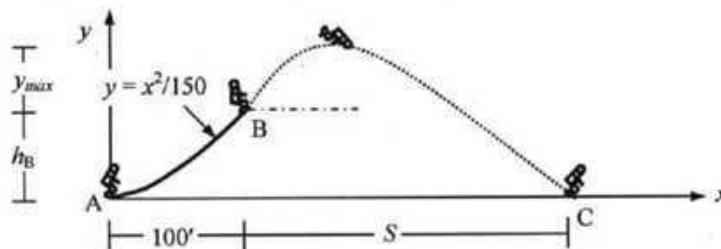

4. The figure below shows a box C (weighing  $W_C = 100$  lb) being pulled by boxes A and B (weighing  $W_A = W_B = 100$  lb) over two smooth pulleys. Calculate the acceleration of box C, if the angle  $\theta$  is equal to (i)  $10^\circ$ , (ii)  $80^\circ$ .

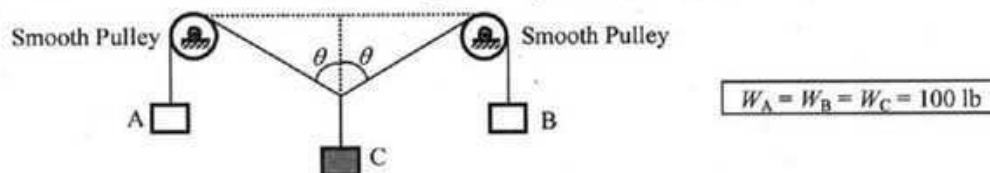

**The University of Asia Pacific**  
**Department of Civil Engineering**  
**Mid-Term Examination Spring 2012.**  
**Program: B.Sc. Engineering (Civil)**

Course Title: Surveying  
 Time : 1 hr

Course Code: CE 105

Credit: 4.0  
 Full Marks: 60

There are **Four** questions in this section. Answer any **Three**

1. (a) Explain with neat diagrams the construction and working principle of an optical square. (10)  
 (b) Write short notes on i) Station ii) Engineer's Chain (5)  
 (c) The length of a line measured with a 30 metre chain was found to be 250 metres. (5)  
 Calculate the true length of the line if the chain was 10 cm too long.

2. (a) What are the difference between Chain surveying and Levelling? (4)  
 (b) For the following traverse, compute the length CD so that A,D and E may be in one (16)  
 straight line

Line	Length (m)	FB
AB	110	83° 20'
BC	170	30° 35'
CD	-	340° 40'
DE	220	15° 36'

3. (a) Write short notes on i) Magnetic declination ii) Local Attraction (6)  
 (b) The following consecutive readings were taken with a level (14)  
 6.21, 4.92, 6.12, 8.42, 9.81, 6.63, 7.91, 10.21, 9.22, 7.32, 6.45  
 The level was shifted after 4<sup>th</sup>, 6<sup>th</sup> and 9<sup>th</sup> readings. The reduced level at first point was 150 ft. Calculate the reduced levels of the points by using Height of Instrument Method and apply usual arithmetic check.
4. (a) What are the difference between Height of Instrument Method and Rise and Fall Method? (4)  
 (b) Write a short note on reciprocal ranging. (6)  
 (b) Calculate the sag correction for 30 m steel under a pull of 100 N in three equal spans of 10 m each. Weight of one cubic cm of steel = 0.078 N. Area of cross-section of tape = 0.04 sq. cm. (10)

**The University of Asia Pacific**  
**Department of Civil Engineering**  
**Mid Semester Examination Spring 2012**

Course No.: CE 105  
Full Marks: 60 (25+20+15)

Course Title: Surveying  
Time: 1 hour

Answer any **ALL** three.

1. For the closed polygon traverse given in the following table (bearing in degree-minute-second and length in feet) compute and tabulate: unbalanced departure and latitude, linear misclosure and relative precision. The coordinate for point A is (10000, 5000). Balance the traverse using compass rule. Finally, calculate the area of the traverse.

Line	Bearing	Length
AB	N44-59-52E	510.42
BC	N46-00-10W	668.90
CD	S44-59-58W	755.76
DA	S66-45-50E	691.78

2. The readings for the leveling survey are given in the following (in meters):

Setup 1: A(0.12), B(0.09), C(0.3), D(0.07)

Setup 2: E(0.8), F(0.6), G(0.04), H(1.0)

The reduced level at A was 59.42 feet. Then, a total station was setup at point C and G to measure the elevation of the top point of a building. Height of the instrument at C and G are respectively 1.69 meters and 1.67 meters. The line CG was measured in catenary and was found to be 41.6 meters. The temperature during observation was 10 degree C and tension applied 15 kgf. The coefficient of expansion was 0.000011 per degree C, weight per unit length of tape = 0.03 kg/m(w); density of steel = 7690 kg/m<sup>3</sup>,  $E = 210 \times 10^3$  N/mm<sup>2</sup>. Other field observations are: angle C = 44-12-34 (degree-minute-second), angle G = 39-26-56;  $v_1 = 8-12-47$ ,  $v_2 = 5-50-10$ . Standard temperature of the tape is 20 degree C and standard tension is 10 kgf. What is the elevation of the top point of the building?

3. What are the common errors in leveling, linear measurement and traverse survey? How will you test if your tilting level does not have error? Explain mathematically.

**The University of Asia Pacific**  
**Department of Civil Engineering**  
**Midterm Examination Spring 2012**

Course # : CE-107

Course Title: Introduction to Civil &amp; Environmental Engineering

Full Marks: 45 (15 X 3 = 45)

Time: 1 hour

Answer any **three (3)** questions of your choice out of the following **four (4)**

- 1a) Mention few simple points related to the understanding of science, engineering and technology. 7.5
- 1b) Mention some (at least six) very important roles of civil engineers in the development of infrastructure. 6
- 1c) What are the major foci of any civil engineering project. 1.5
- 2a) Define civil engineering according to ASCE (American Society for Civil Engineers). Mention few names of infrastructures that civil engineers are involved in developing. 3+2=5
- 2b) What are the major sub-disciplines of civil engineering? Mention the names of some other sub-disciplines that are always inevitably participatory in any civil engineering project. 1.5+1.5=3
- 2c) Discuss, in brief, "civil engineering" as a career. 5
- 2d) Give the names in details of the following codes with their related fields. 2  
 (i). BNBC (ii). ASTM (iii). ACI (iv). AASHTO
- 3a) Categorize building/construction material based on specific property of material. What are the major factors for choice of materials? 3+2=5
- 3b) Mention (names only) few types of loads to be considered in design. 2
- 3c) Categorize building based on type of occupancy. 3
- 3d) Mention (names only) major components of a building. 5
- 4) A four-storied residential building is to be constructed. Estimate the total construction cost as per the following particulars and specifications of the building. Use PWD schedule and other relevant information provided in the attached appendix. 15

Sl No	Particulars	Specification
01	Land Size	20m x 30m
02	Building type	Residential (Standard)
03	Allowable Bearing Capacity ( $q_u$ )	3 ksf
02	Floor Level	Four
03	Plinth Area	300 Square meter
04	Construction Material	RCC Structure 1:1.5:3 (Stone Chips)
05	Ground Floor	Car Parking
06	Roof top RCC water tank including beams and supports etc	2000 Gallons
07	For mosaic work in all rooms including stair, tiles in bathrooms and normal finishing	950 per sqm
08	Underground water reservoir, distribution line, water pump, pump house, WASA charge	6000 gallons
09	Boundary wall	RCC frame

**University of Asia Pacific**  
**Department of Civil Engineering**  
**Mid Term Examination, Spring 2012**

Course # : CE 107  
Full Marks:40

Course Title: **Introduction to Civil and Environmental Engg.**  
Time: 1 hours

---

1. Describe the following (any 4): (4x2=8)
  - a. Environmental Engineering
  - b. Age Structure
  - c. Water quality
  - d. Bio-diversity
  - e. Causes of flood in Bangladesh
  - f. Wet land conversion
  
2. Describe basic environmental issues. (4)
  
3. In the year 2000, population of Dhaka city was about 5 million. When the population of Dhaka city can be expected to become 20 million with a growth rate of 2.5%. Assume population follows exponential growth. (2)
  
4. Define water pollution? Write any four different categories of water pollutant along with their sources and impact. (2+4=6)
  
5. Assume that a population follows a simple logistic growth curve. Find the maximum sustainable yield as a function of carrying capacity, the current population size and current growth rate. (4)
  
6. In 1971 population of Bangladesh was 70 million and it reached 140 million in 2010. If population growth follows a logistic curve until it stabilizes at 20 million. Find out the growth rate and maximum sustainable yield. (4)
  
7. Define ecosystem and what are its components? (2+2=4)
  
8. Describe different uses and issues of water. (8)

**University of Asia Pacific**  
**Department of Civil Engineering**  
**Mid Semester Examination Spring 2012**  
**Program: B. Sc. Engineering (Civil)**

Course Title : Engineering Materials  
Time: One Hour

Course Code: CE 201  
Full Marks: 50

**Answer ALL questions. The figures in the right margin indicate the marks of the questions.**

1. The specified FM of coarse aggregate of a bridge project is 6.6. The sieve analysis data of a coarse aggregate sample collected for the bridge project are summarized below: 20

ASTM Sieve	Materials Retained (g)
3 inch	0
1.5 inch	0
¾ inch	0
½ inch	2000
3/8 inch	500
#4	2400
#8	0
#16	0
#30	0
#40	0
#50	0
#100	0
#200	50
Pan	50

- (i) Calculate the FM of the sample,
- (ii) Draw the grading curve of the sample,
- (iii) Make a brief discussion on the FM, sieve analysis data, and grading curve,
- (iv) What measures are necessary to improve the grading of the sample?

Sieve openings of #40 and #200 sieves are 0.425 mm, and 0.075 mm respectively.

2. A mixture proportion of mortar is to be prepared based on the following data: 10

Sand to cement ratio (weight ratio) = 2.5,

W/C=0.50,

Specific gravity of cement = 2.9,

Specific gravity of sand = 2.6,

Air content = 2% ,

- (i) Calculate the unit contents of sand, cement, and water,
- (ii) Calculate the unit weight of mortar,
- (iii) How do you consider the bulking of sand in the volumetric mix-design?

3. (a) Compare the following: 15

- (i) Initial setting time and final setting time of cement,
- (ii) Setting and hardening of cement,
- (iii) Bulk specific gravity and apparent specific gravity,
- (iv) Kiln burning and clamp burning of brick,
- (v) Creep and relaxation,
- (vi) Ductile and brittle materials,
- (vii) False setting and flash setting of cement,
- (viii) SSD condition and wet/moist condition of aggregate,
- (ix) OPC cement and blended cement, and
- (x) Morphology of CSH and CAH.

- (b) What is hydration of cement? Write the hydration reactions. 3

- (c) Explain the strength development process of brick during burning. 2

**The University of Asia Pacific**  
**Department of Civil Engineering,**  
**Midterm Examination Spring 2012**

Course # : CE-203

Course Title: Engineering Geology &amp; Geomorphology

Full Marks: 60 (20 X 3 = 60)

Time: 1 hour

Answer any three (3) questions of your choice out of the following four (4)

- 1a) Define geomorphology. With the aid of a schematic diagram, show thicknesses of different parts of geosphere/lithosphere. 1+4=5
- 1b) Distinguish between sediments and sedimentary rocks. With the aid of a schematic diagram, show the formation of different types of rocks based on origin. Provide one example of each type of these rocks. 3+5.5+1.5=10
- 1c) Define geomorphic process, weathering and erosion. Mention the names of different weathering processes. 3+2=5
- 2a) Differentiate precipitation, infiltration and percolation. Draw a schematic diagram of hydrologic cycle and show their relative locations of occurrences in conjunction with runoff. 4.5+6=10.5
- 2b) In the following basin, for what value of  $x$ , the flow rate ( $Q_p$ ) will be the maximum? Also calculate the CC of the basin. 9.5

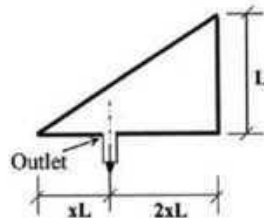

- 3a) Mention the major factors affecting runoff. 4
- 3b) With sketches define axial length, time of concentration and flood hydrograph. 6
- 3c) For the drainage area as shown below, calculate peak runoff in  $\text{ft}^3/\text{s}$ . Use  $C_2 = 0.7$ ,  $C_3 = 0.4$  and  $C_4 = 0.6$  and  $I = 0.05$  in/min. 10

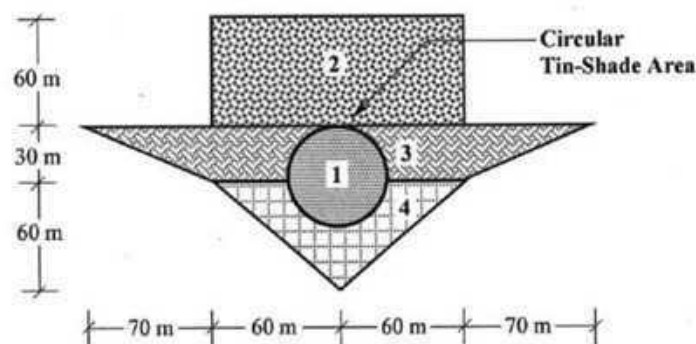

- 4a) What is diastrophism? Draw a neat sketch of a typical fold geometry showing its different components. 1.5+4.5=6
- 4b) Classify folds (mention names only). Draw neat sketches of any two types of fold. 1.5+4=5.5
- 4c) Define fault and joint. Classify fault (mention names only). Draw a neat sketch of an oblique fault. 2+3+3.5=8.5

University of Asia Pacific  
Department of Civil Engineering  
Mid Term Examination-Spring 2012  
Program: B.Sc. Engineering (Civil)

A

Course No: CE 205  
Course Title: Numerical Analysis & Computer Programming

Time: 1 hour  
Full Marks: 20(=5×4)

**[Answer any three questions]**

1. Solve the following system of equation by *Gauss Jordan* method,

$$\begin{aligned} a + b + c &= 6 \\ 3b + 4c &= 20 \\ 2a + 3c &= 13 \end{aligned}$$

2. Using the *Iteration* method, find the root of the equation

$$\ln x = \frac{\sin x}{x^2}$$

up to four decimal places,  $\epsilon = 0.001$

3. Solve the following system of equations using *Crout's* method:

$$\begin{aligned} u + v + w &= 1 \\ 3u + v &= 5 - 3w \\ 10 + 2v + 5w &= u \end{aligned}$$

4. Using *Reguli-Falsi* method find the solution of  $f(x) = 3x - \sqrt{1 + \cos x}$ ,  
desired accuracy = 0.0001

5. Jui (mass  $M$  kg), standing ( $V = 0$  m/s) on slippery ice, catches her leaping dog, Atta (mass  $m$  kg), moving horizontally at  $v$  m/s. Write a program that can read  $M, m, V, v$  in fps unit, convert the value in SI unit and calculate the speed ( $V_f$ ) of Jui and her dog after the catch.  
[Here, 1 kg = 2.2 lb, 1 m = 3.28 ft,  $(M+m)V_f = MV + mv$ ]

6. Write a program that starts with two options.

1. for simply supported and
2. for cantilever.

Then the program reads the span ( $L$ ) and UDL ( $w$ ) and calculates the value of bending moment and shear force at any distance  $x$  from the left face.

[Here,  $SF = \frac{wL}{2} - wx$  (for simply supported),  $wL - wx$  (for cantilever)

and  $BM = (wx/2)(L-x)$  (for simply supported),  $(w/2)(x^2 - L^2)$  (for cantilever)]

University of Asia Pacific  
Department of Civil Engineering  
Mid Term Examination Spring 2012

Course Title: Fluid Mechanics  
Time: 1.0 hour

Course No: CE 221  
Full Marks: 60

*[The symbols have their usual meanings]  
[The figures at the right margin indicate full marks]*

1. Differentiate between the following terms (any three): (3×4 =12)
  - i. Hydraulics and hydrodynamics
  - ii. Piezometer and manometer
  - iii. Cohesion and adhesion.
  - iv. Absolute pressure and gage pressure
2. (a) Define the following terms (any two): (2×2 = 4)
  - i. Viscosity
  - ii. Capillarity
  - iii. Buoyancy.

(b) As the temperature increases, the viscosities of all liquids decrease, whereas the viscosities of all gases increase. Explain briefly. (5)
3. The density and kinematic viscosity of a fluid at 20°C are 1.32 gm/cm<sup>3</sup> and 18 stokes, respectively. Calculate the velocity gradient and intensity of shear stress at a distance 4 cm from the lower plate. Given that the fluid is filled between two parallel plates 8 cm apart and the upper plate is moving at a velocity of 120 cm/s, the lower one being stationary. Assume the velocity distribution is given by (8)

$$u = 120-k(8-y)^2.$$
4. Derive the expression for center of pressure of a submerged plane surface. (7)
5. Calculate the capillary rise/drop in a glass tube of 3.50 mm diameter when immersed in mercury at 20°C. The values of  $\sigma$  and  $\rho$  of mercury at 20°C are 0.51 N/m and 13,550 kg/m<sup>3</sup>, respectively. Assume a reasonable value of the contact angle. (6)
6. A liquid A weights 7.5 kN/m<sup>3</sup>, Liquid B weights 12.8 kN/m<sup>3</sup>. Manometer liquid M is mercury. If the pressure at B is 250 kN/m<sup>2</sup>, find the pressure at A. (see figure 1) (8)

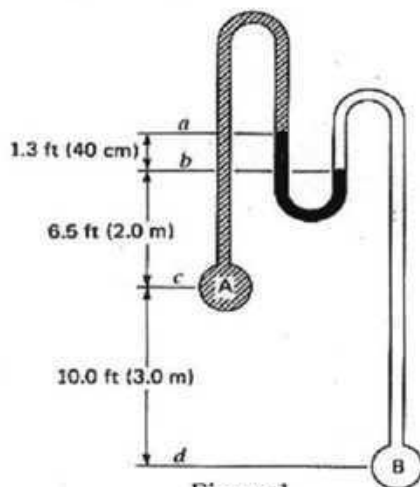

Figure 1

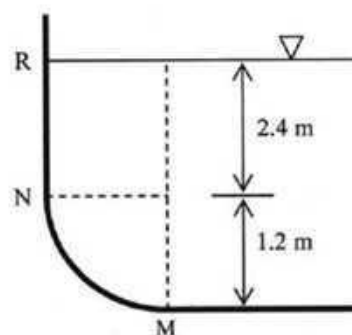

Figure 2

7. Find the resultant force acting on the curved section MN of the open tank as shown in Figure 2. The shape of the curve is a quadrant of a circle of radius 1.2 m. The upper portion of the curve is at a depth of 2.4 m from the free water surface. The length of the tank is 3.0 m. (see figure 2) (10)

**University of Asia Pacific,  
Department of Civil Engineering  
Spring 2012  
Program: B. Sc. Engineering (Civil)**

Course Title: Solid Mechanics I  
Time: 1 hours

Credit Hours: 3.0

Course Code: CE 211  
Full Marks: 60 (= 15 x 4)

There are 3 questions below. **Answer all the questions.**

1. Draw the SFD and BMD of the beams loaded as shown below (**any two**) (15 x 2)  
[Assume concentrated moment = 100 k', load = 10 k, UDL = 1 k', peak of triangular load = 1.5 k'].

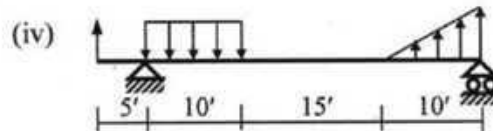
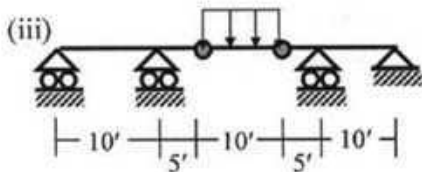
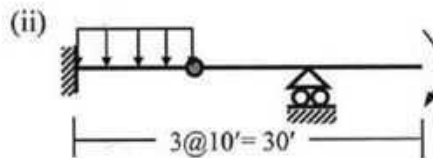
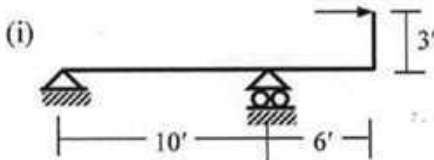

2. Calculate the maximum allowable load  $P$  in the simply supported beam loaded as shown below, if the allowable compressive stress in the cross-section is 20 ksi and allowable tensile stress 15 ksi.

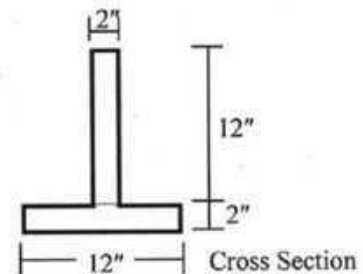
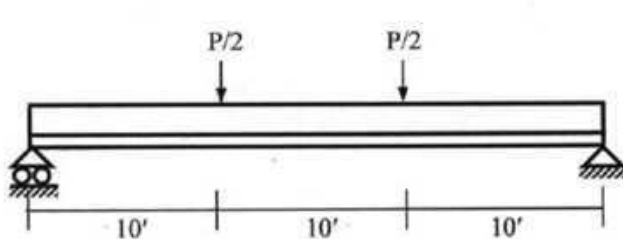

3. (i) Calculate the maximum allowable value of  $w$  (k/ft) if the maximum shear stress of the beam shown in figure is not to exceed 100 psi. (Hint: maximum shear stress occurs at the level of centroid of the beam cross-section).

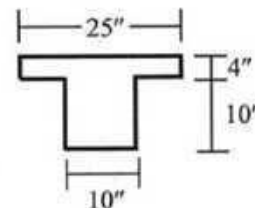
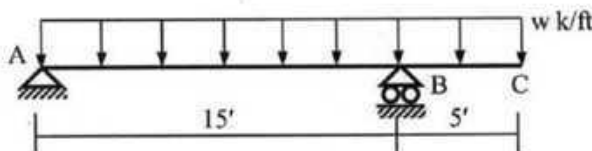

**The University of Asia Pacific**  
**Department of Civil Engineering**  
**Mid Semester Examination Spring 2012**

Course No.: CE 211  
 Full Marks: 30 (= 3 × 10)

Course Title: Mechanics of Solids I  
 Time: 1 hour

There are **four** questions in this paper. Answer any **three**.

1. Draw axial force, shear force and bending moment diagram for the beam.

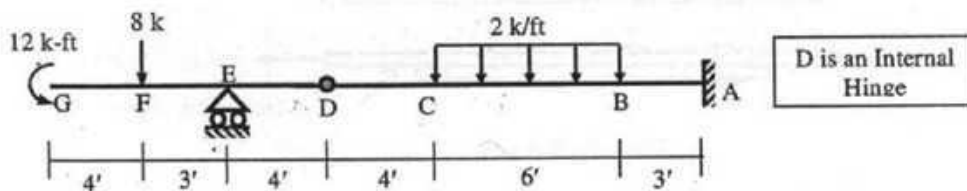

2. For the member X of the truss shown below, calculate the lengths of  $\frac{3}{4}$  inch weld required on three sides of the member.

[Given: Allowable shear stress = 16 ksi].

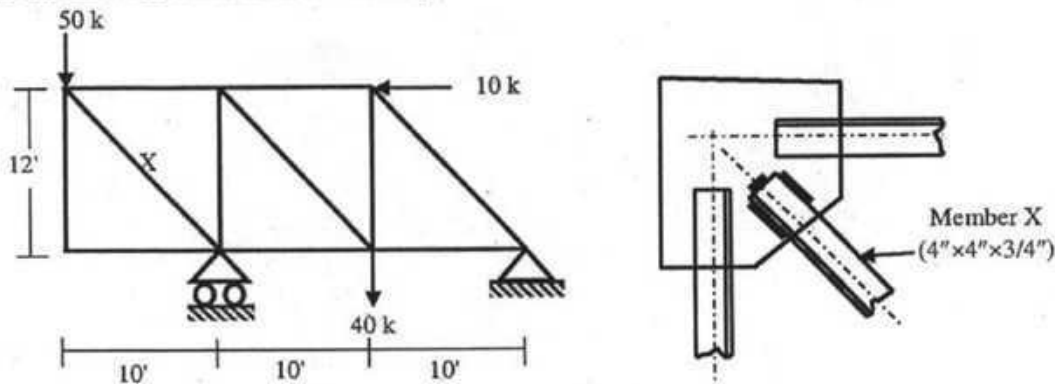

3. For the beam *abcdef* loaded as shown in the figure below

- Derive the equations for shear force and bending moment using Singularity Functions,
- Also calculate shear force at point *c* and bending moment at the right of point *d*.

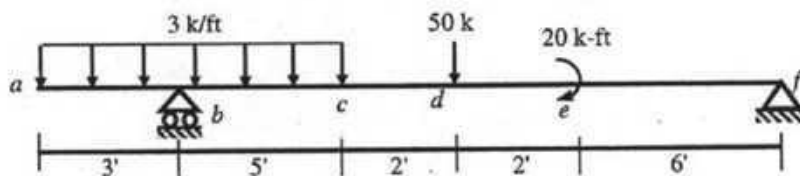

4. Find the capacity of the multi-riveted structural joint shown in the figure. All the rivets are normally 22 mm in 24 mm diameter holes. Allowable stresses are 150 MPa in tension, 100 MPa in shear and 335 MPa in bearing.

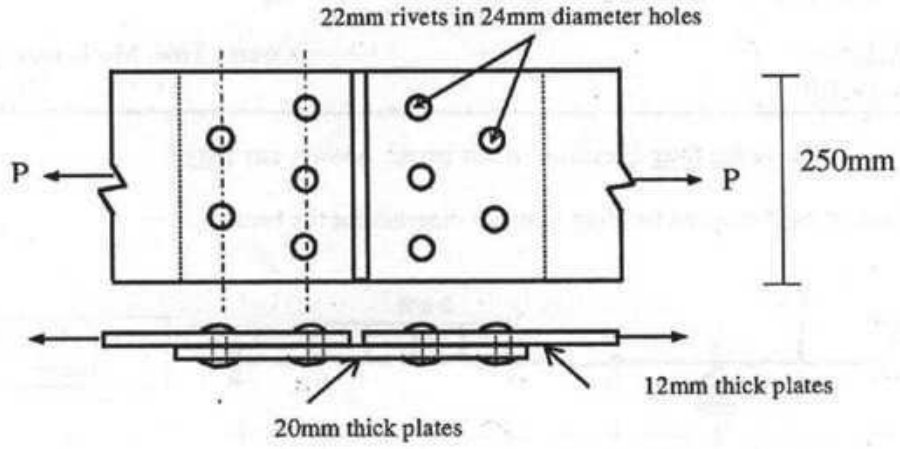

**University of Asia Pacific**  
**Department of Civil Engineering**  
**Mid Term Examination Spring 2012**  
**Program: B.Sc. Engineering (Civil)**

Course Title: Mechanics of Solids II  
 Time : 1 hour

Credit Hours: 3.0

Course Code: CE 213  
 Full Marks : 30 (3x10)

(There are **FOUR** questions. Answer any **THREE**)

1. Calculate the magnitude and location of the maximum shear stress in the compound section shown below when subjected to a torque of 25 k-ft. Also calculate the diameter ( $D$ ) of the circular section that has the same maximum shear stress when subjected to the same torque.

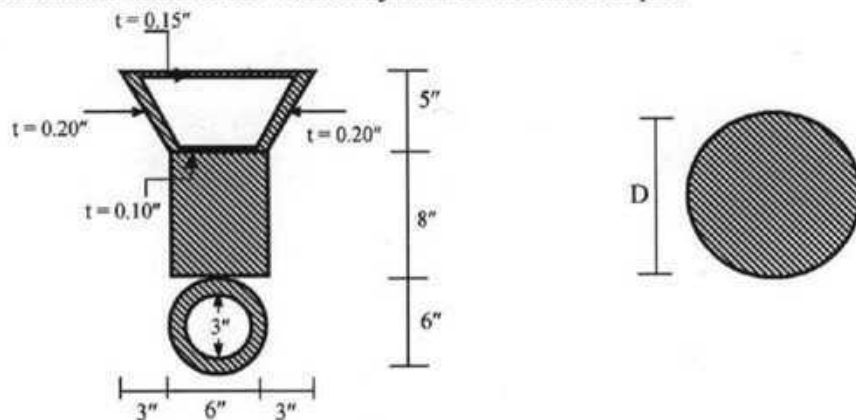

2. Calculate the torsional shear stress at C for the indeterminate beam shown below (Neglect stress concentration) [Given  $G = 12000$  ksi].

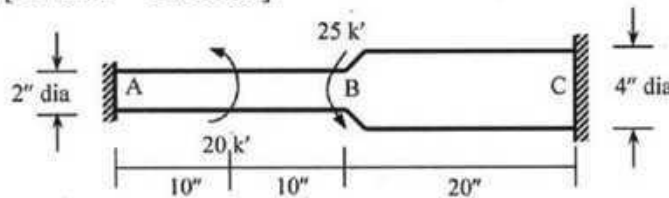

3. Use the Mohr's Circle or stress transformation to calculate the normal stress and shear stress on the plane  $a-a'$ . Also calculate the magnitude of maximum & minimum normal stress and maximum & minimum shear stress.

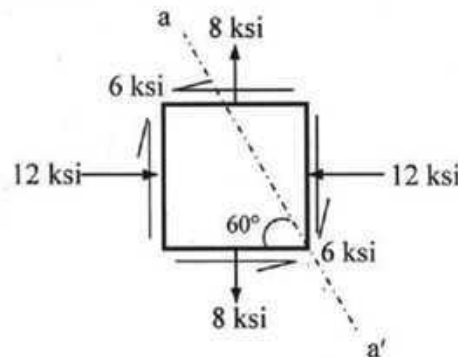

4. A simple beam with a cross-section of 2m x 1.5 m has a span of 20m and carries a concentrate load P as shown in following figure. The loading plane is inclined 60° clockwise with vertical. Determine the required load P so that the maximum stress due to bending does not exceed 12 MPa. Neglect self-weight of beam. Also locate the neutral axis.

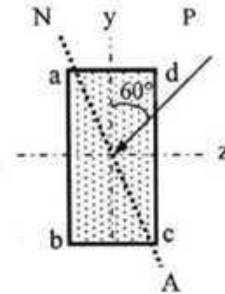
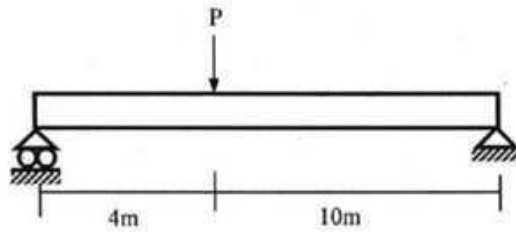

#### List of Useful Formulae for CE 213

\* Torsional Rotation  $\phi_B - \phi_A = \int (T/J_{eq}G) dx$ , and  $= (TL/J_{eq}G)$ , if T,  $J_{eq}$  and G are constants

Section	Torsional Shear Stress	$J_{eq}$
Circular	$\tau = Tc/J$	$\pi d^4/32$
Thin-walled	$\tau = T/(2A t)$	$4A^2/(ds/t)$
Rectangular	$\tau = T/(\alpha b t^2)$	$\beta b t^3$

b/t	1.0	1.5	2.0	3.0	6.0	10.0	$\alpha$
$\alpha$	0.208	0.231	0.246	0.267	0.299	0.312	0.333
$\beta$	0.141	0.196	0.229	0.263	0.299	0.312	0.333

\* Biaxial Bending Stress:  $\sigma_x(z, y) = M_x y/I_x + M_y z/I_y$

\* Combined Axial Stress and Biaxial Bending Stress:  $\sigma_z(x, y) = -P/A - M_x y/I_x - M_y z/I_y$

\* Corner points of the kern of a Rectangular Area are (b/6, 0), (0, h/6), (-b/6, 0), (0, -h/6)

\* Maximum shear stress on a Helical spring:  $\tau_{max} = \tau_{direct} + \tau_{torsion} = P/A + Tr/J = P/A (1 + 2R/r)$

\* Stiffness of a Helical spring is  $k = Gd^4/(64R^3N)$

\*  $\sigma_{xx}' = (\sigma_{xx} + \sigma_{yy})/2 + \{(\sigma_{xx} - \sigma_{yy})/2\} \cos 2\theta + (\tau_{xy}) \sin 2\theta = (\sigma_{xx} + \sigma_{yy})/2 + \sqrt{\{[(\sigma_{xx} - \sigma_{yy})/2]^2 + (\tau_{xy})^2\}} \cos(2\theta - \alpha)$

$\tau_{xy}' = -\{(\sigma_{xx} - \sigma_{yy})/2\} \sin 2\theta + (\tau_{xy}) \cos 2\theta = \tau_{xy}' = -\sqrt{\{[(\sigma_{xx} - \sigma_{yy})/2]^2 + (\tau_{xy})^2\}} \sin(2\theta - \alpha)$

where  $\tan \alpha = 2 \tau_{xy}/(\sigma_{xx} - \sigma_{yy})$

\*  $\sigma_{xx(max)} = (\sigma_{xx} + \sigma_{yy})/2 + \sqrt{\{[(\sigma_{xx} - \sigma_{yy})/2]^2 + (\tau_{xy})^2\}}$ ; when  $\theta = \alpha/2, \alpha/2 + 180^\circ$

$\sigma_{xx(min)} = (\sigma_{xx} + \sigma_{yy})/2 - \sqrt{\{[(\sigma_{xx} - \sigma_{yy})/2]^2 + (\tau_{xy})^2\}}$ ; when  $\theta = \alpha/2 \pm 90^\circ$

\*  $\tau_{xy(max)} = \sqrt{\{[(\sigma_{xx} - \sigma_{yy})/2]^2 + (\tau_{xy})^2\}}$ ; when  $\theta = \alpha/2 - 45^\circ, \alpha/2 + 135^\circ$

$\tau_{xy(min)} = -\sqrt{\{[(\sigma_{xx} - \sigma_{yy})/2]^2 + (\tau_{xy})^2\}}$ ; when  $\theta = \alpha/2 + 45^\circ, \alpha/2 - 135^\circ$

\* Mohr's Circle: Center (a, 0) =  $[(\sigma_{xx} + \sigma_{yy})/2, 0]$  and radius  $R = \sqrt{\{[(\sigma_{xx} - \sigma_{yy})/2]^2 + (\tau_{xy})^2\}}$

\* For Yielding to take place

Maximum Normal Stress Theory (Rankine):  $|\sigma_1| \geq Y$ , or  $|\sigma_2| \geq Y$ .

Maximum Normal Strain Theory (St. Venant):  $|\sigma_1 - \nu\sigma_2| \geq Y$ , or  $|\sigma_2 - \nu\sigma_1| \geq Y$ .

Maximum Shear Stress Theory (Tresca):  $|\sigma_1 - \sigma_2| \geq Y$ ,  $|\sigma_1| \geq Y$ , or  $|\sigma_2| \geq Y$

Maximum Distortion-Energy Theory (Von Mises):  $\sigma_1^2 + \sigma_2^2 - \sigma_1\sigma_2 \geq Y^2$

**University of Asia Pacific**  
**Department of Civil Engineering**  
**Mid Term Examination-Spring 2012**  
**Program: B.Sc. Engineering (Civil)**

Course No: CE 311

Time: 1 hour

Course Title: Structural Engineering I

Full Marks: 20 (=4× 5)

[Answer any 4 of the following 5 questions]

1. Draw the Shear Force and Bending Moment diagram of the frame.

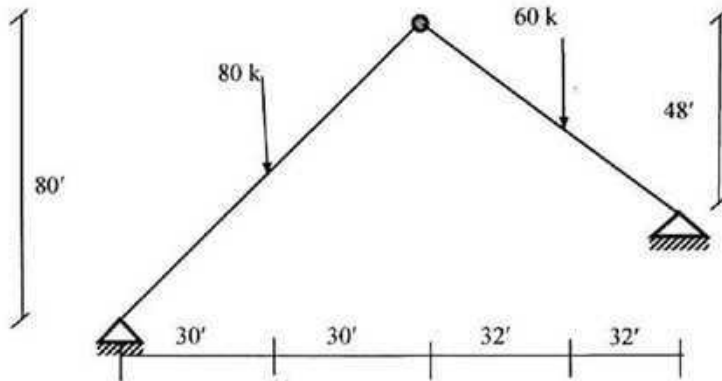

2. For the plate girder shown below, draw the influence lines of  $V_{2-3}$  and  $M_3$ .

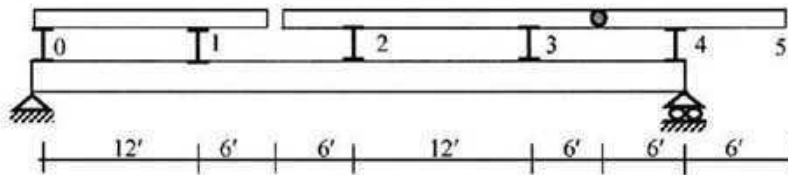

3. Draw the influence lines of  $R_C$ ,  $V_E$ ,  $V_{CL}$ ,  $V_{FR}$ ,  $M_C$  and  $M_G$ .

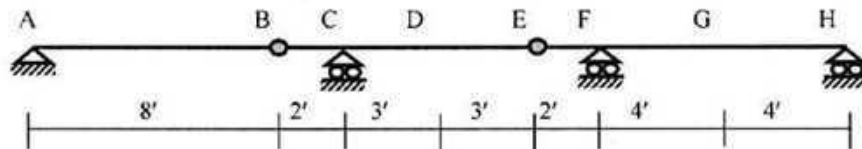

4. Determine the stability/determinacy of the following structures-

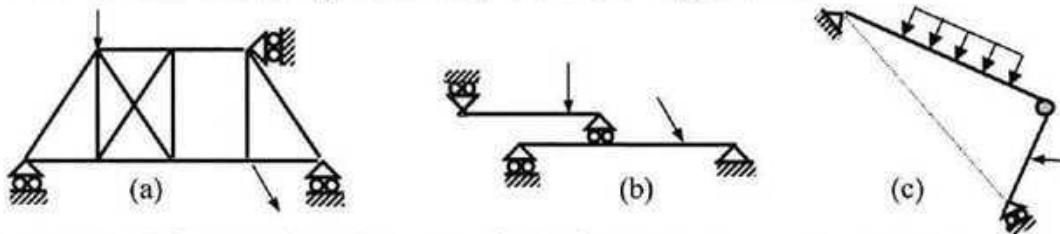

5. Draw the influence lines of  $V_{I-I}$ ,  $M_{I-I}$  for the frame (Load moves from A to B).

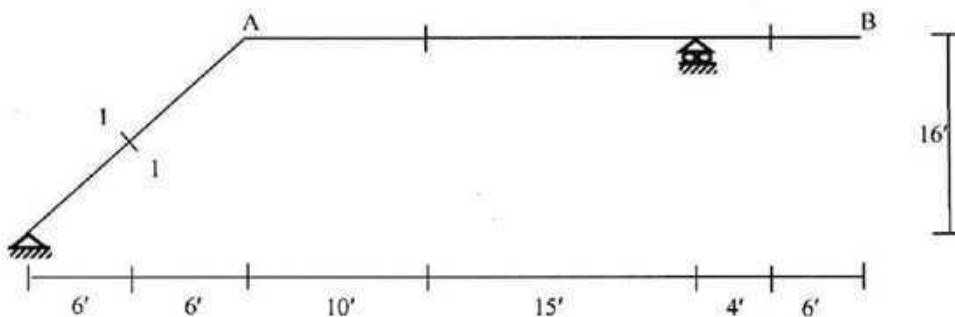

**University of Asia Pacific**  
**Department of Civil Engineering**  
**Mid-term Examination Spring 2012**

Course Title: Structural Engineering I  
 Time: 1 hour

Credit Hours: 3.0

Course Code: CE 311  
 Full Marks: 20

There are **3 (Three)** questions below. **Answer all the questions.**

1. Draw Influence Lines of (i)  $R_f$  (ii)  $V_g$  (iii)  $M_e$  (6)

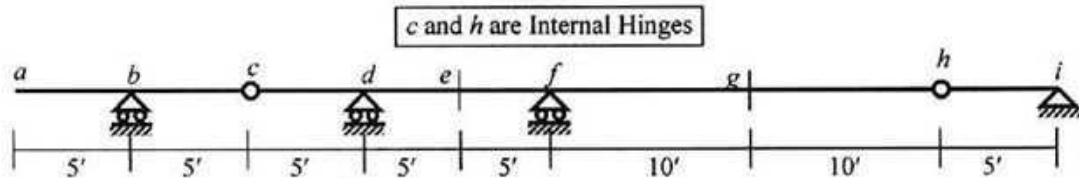

2. Draw Influence Lines of (i)  $V_p$  (ii)  $M_q$  (8)

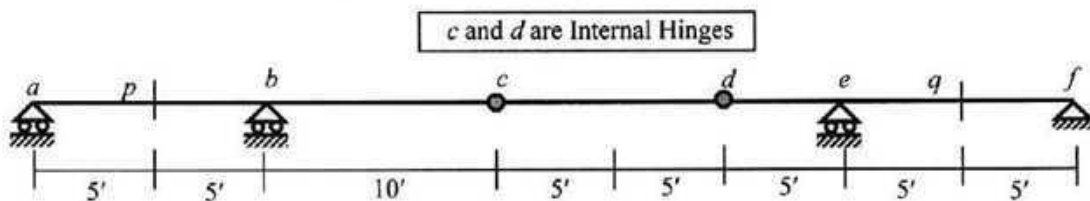

Also find out (i)  $V_p(\max)$  and (ii)  $M_q(\max)$  for the following type of vehicle.

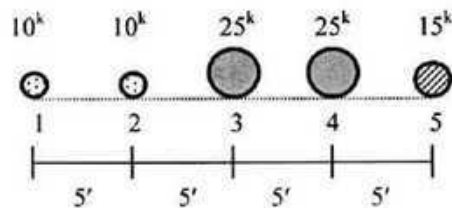

3. Draw the SFD and BMD of the beam loaded as shown below (Any One) (6)

[Assume concentrated load = 10 k, UDL = 1 k/ft, peak of triangular load = 1.5 k/ft].

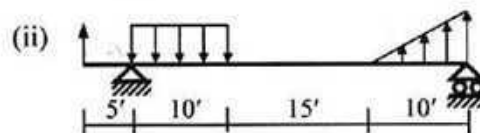
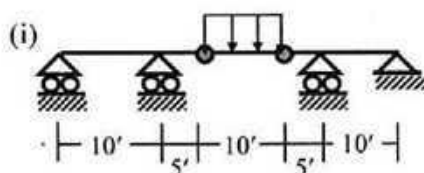

**University of Asia Pacific**  
**Department of Civil Engineering**  
**Mid Semester Examination Spring 2012 (Set A)**

Course #: CE 311  
 Full Marks: 40 (= 4 × 10)

Course Title: Structural Engineering I  
 Time: 1 hour

1. Determine the degree of static indeterminacy (dosi) of the frame *abcde* shown in Fig. 1.

Also draw its AFD, SFD and BMD, assuming

- (i) the moment  $M_0$  is divided equally at joint *c* between members *ce* and *ca*,  
 (ii) a point of inflection (no bending moment) at *d*.

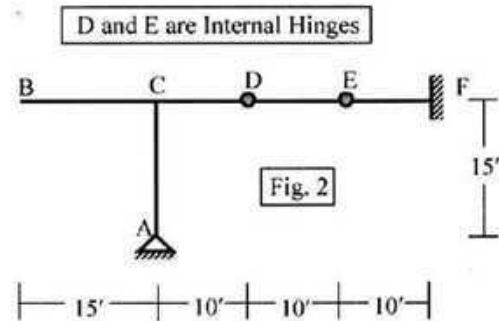
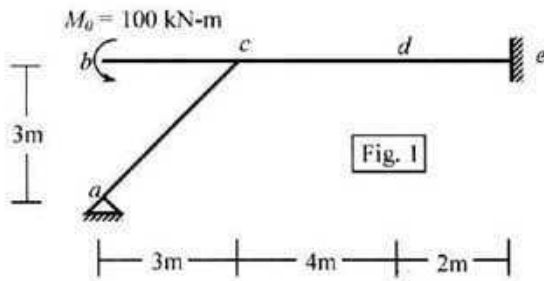

2. (i) Draw the influence lines of support reactions  $X_A$  and  $Y_F$  for the frame ABCDEF shown in Fig. 2, if unit load moves over (a) beam BF, (b) column AC.

- (ii) Determine the degree of static indeterminacy (dosi) of the beam *abcde* shown in Fig. 3 and draw the influence lines of  $R_a$ ,  $V_c$  and  $M_b$ .

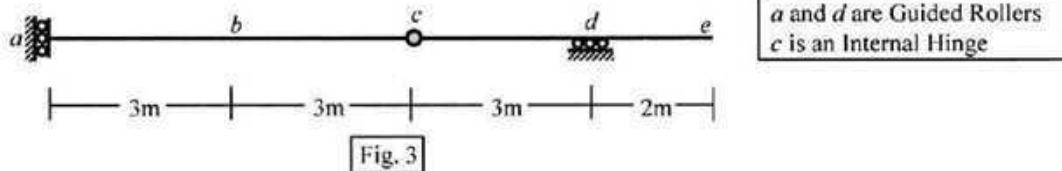

3. Draw the influence lines of  $R_c$ ,  $V_{c(Left)}$ ,  $V_{g(Left)}$  and  $M_b$  for the plate girder *abcdefghi* shown in Fig. 4 if unit load passes over the stringers AB, BC, CD and DE..

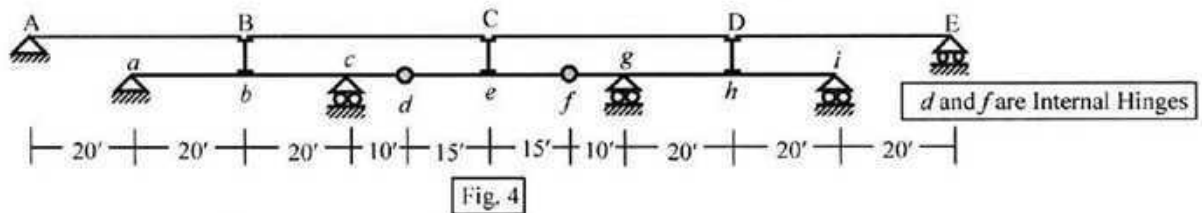

4. Determine the degree of static indeterminacy (dosi) of the truss *abcdefgh* shown in Fig. 5 and also draw the influence lines of the reaction at support *e* and forces in members *cd* and *gh*, if unit load passes over the stringers AB, BCD and DE.

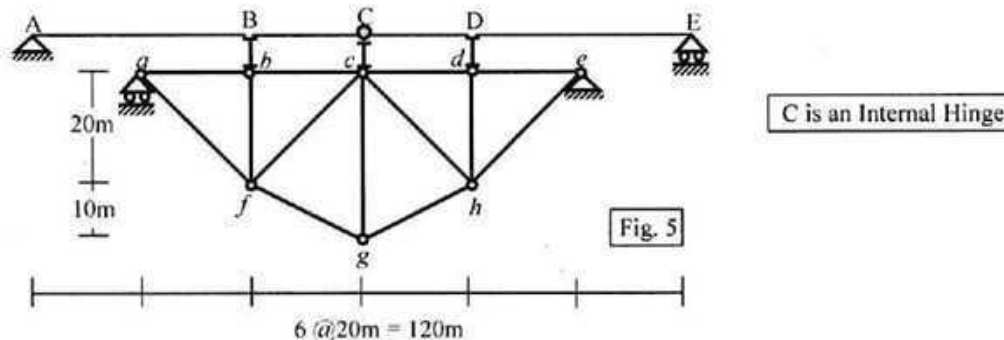

**University of Asia Pacific**  
**Department of Civil Engineering**  
**Mid Semester Examination Spring 2012 (Set B)**

Course #: CE 311  
 Full Marks: 40 (= 4 × 10)

Course Title: Structural Engineering I  
 Time: 1 hour

1. Determine the degree of statical indeterminacy (dosi) of the frame *abcde* shown in Fig. 1.

Also draw its AFD, SFD and BMD, assuming

- (i) the moment  $M_0$  is divided equally at joint *c* between members *ce* and *ca*,  
 (ii) a point of inflection (no bending moment) at *b*.

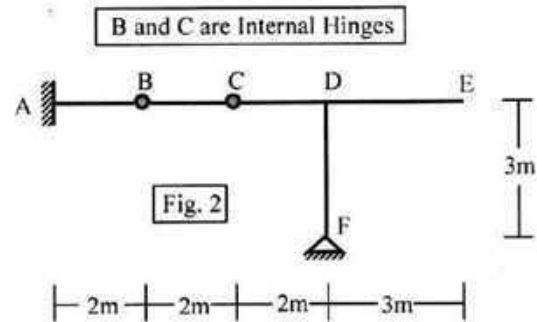
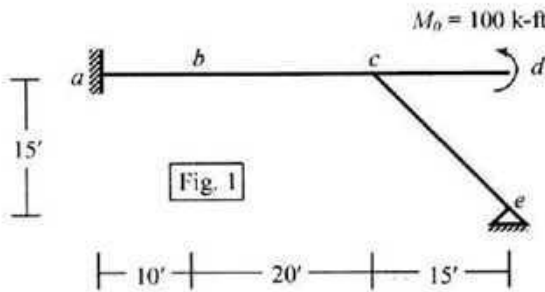

2. (i) Draw the influence lines of support reactions  $X_F$  and  $Y_A$  for the frame ABCDEF shown in Fig. 2, if unit load moves over (a) beam AE, (b) column DF.  
 (ii) Determine the degree of statical indeterminacy (dosi) of the beam *abcde* shown in Fig. 3 and draw the influence lines of  $R_b$ ,  $V_c$  and  $M_d$ .

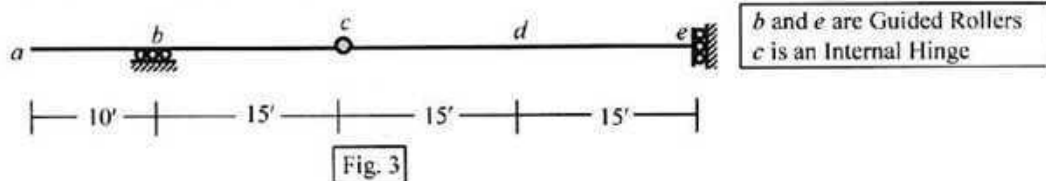

3. Draw the influence lines of  $R_g$ ,  $V_{c(\text{Right})}$ ,  $V_{g(\text{Right})}$  and  $M_b$  for the plate girder *abcdefghi* shown in Fig. 4, if unit load passes over the stringers AB, BC, CD and DE.

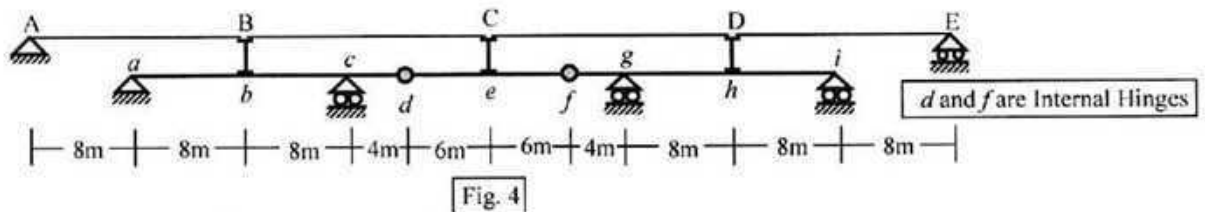

4. Determine the degree of statical indeterminacy (dosi) of the truss *abcdefgh* shown in Fig. 5 and also draw the influence lines of the reaction at support *e* and forces in members *cd* and *gh*, if unit load passes over the stringers AB, BCD and DE.

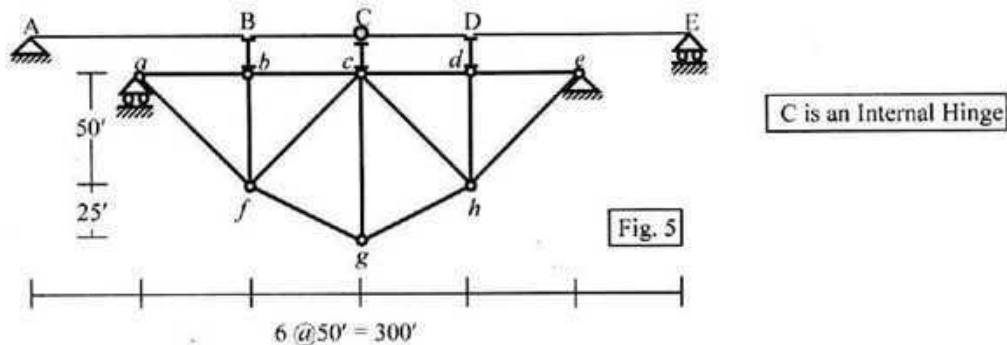

**University of Asia Pacific**  
**Department of Civil Engineering**  
**Mid Term Examination Spring 2012**  
**Program: B.Sc. Engineering (Civil)**

Course Title : Structural Engineering II  
 Time : 1 hour

Course Code: CE 313  
 Full Marks :  $3 \times 10 = 30$

(There are **Four** questions. Answer any **Three**)

1. For the structure shown below, use the Cantilever Method to draw all the Column BMD and Beam BMD. The columns cross-sectional area is given in the parenthesis.

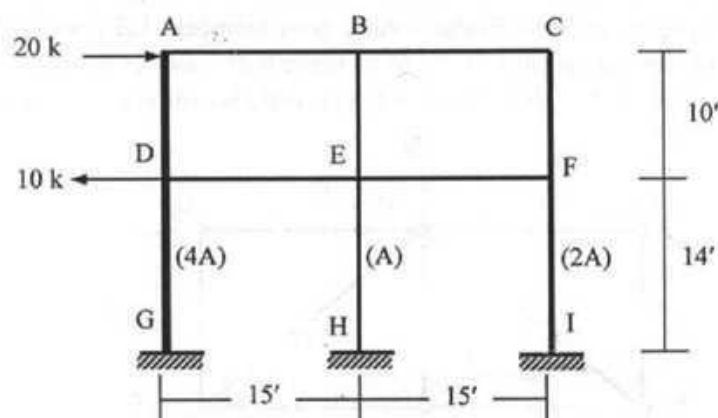

2. In the mill bent shown below,  
 (i) Use the Portal Method to draw the bending moment diagram of the column ABC.  
 (ii) Calculate the forces in GI and FH, assuming them to take equal share of the sectional shear.

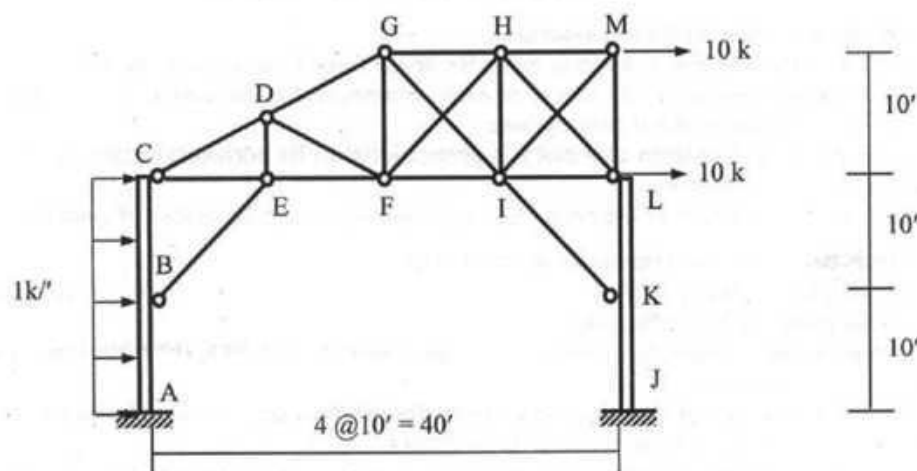

3. Analyze the two-storied frame structure loaded as shown below using the approximate location of hinges to draw the bending moment diagrams of the beams and columns.

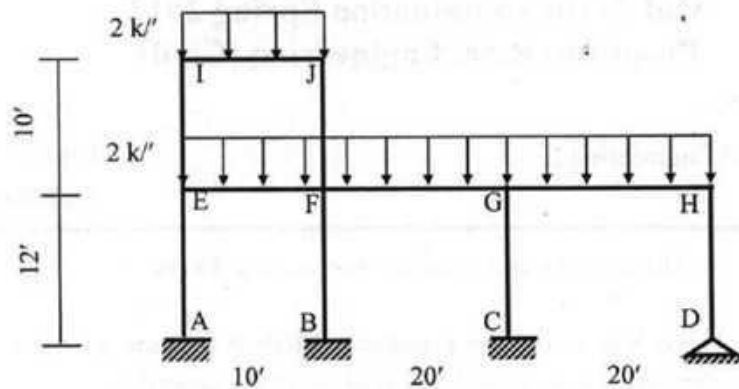

4. Calculate the vertical deflection of the point  $U_2$  of the truss shown below due to the external loads applied, temperature rise of  $30^\circ\text{F}$  in the bottom chord members  $L_0L_1$  and  $L_1L_2$  and a fabrication defects resulting in vertical members  $L_1U_1$  to be made  $0.25''$  shorter than specified.  
[Given:  $\alpha = 5.5 \times 10^{-6}/^\circ\text{F}$ ,  $E = 29000\text{ksi}$  and the parenthesis value indicates area in  $\text{in}^2$ ].

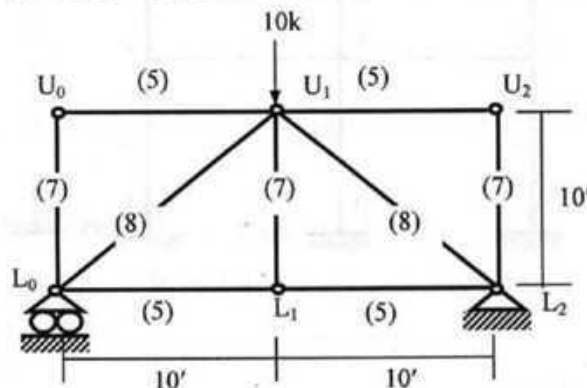

### List of Useful Formulae for CE 313

- Portal Method for multi-storied frames assumes
  - The shear force in an interior column is twice the shear force in an exterior column.
  - There is a point of inflection at the center of each column, and at the center of each beam.
- Cantilever Method is based on three assumptions
  - The axial force in each column of a story is proportional to its horizontal distance from the center of gravity of all the columns of the story.
  - There is a point of inflection at the center of each column, and at the center of each beam.
- Vertical Analysis based on approximate location of hinges
 
$$M_{(+) } = 0.08 wL^2, M_{(-) } = 0.045 wL^2, \quad V_{(+)} = wL/2, \text{ and } V_{(-)} = -wL/2$$
- Vertical Analysis using ACI Coefficients
  - $M_{(+)}$  (i) For end spans, if discontinuous end is (a) unrestrained =  $wL^2/11$ , (b) restrained =  $wL^2/14$
  - (ii) For interior spans =  $wL^2/16$
  - $M_{(-)}$  (i) At the exterior face of first interior supports for (a) Two spans =  $wL^2/9$ , (b) More spans =  $wL^2/10$
  - (ii) At the other faces of interior supports =  $wL^2/11$
  - (iii) For spans not exceeding  $10'$ , of where columns are much stiffer than beams =  $wL^2/12$
  - (iv) At the interior faces of exterior supports, if the support is (a) a beam =  $wL^2/24$ , (b) a column =  $wL^2/16$
  - $V$  (i) In end members at first interior support =  $\pm 1.15wL/2$ , (ii) At all other supports =  $\pm wL/2$
- Deflection of truss due to load, temperature change and misfit,  $\Delta = \sum N_1 dL = \sum N_1 (N_0L/EA + \alpha\Delta T L + \Delta L)$

**University of Asia Pacific**  
**Department of Civil Engineering**  
**Mid Term Examination Spring 2012**  
**Program: B.Sc. Engineering (Civil)**

Course Title : Structural Engineering II  
 Time : 1 hour

Course Code: CE 313  
 Full Marks : 3x10=30

(There are **Four** questions. Answer any **Three**)

1. Analyze the two-storied frame structure loaded as shown below using the approximate location of hinges to draw the bending moment diagrams of the beams and columns.

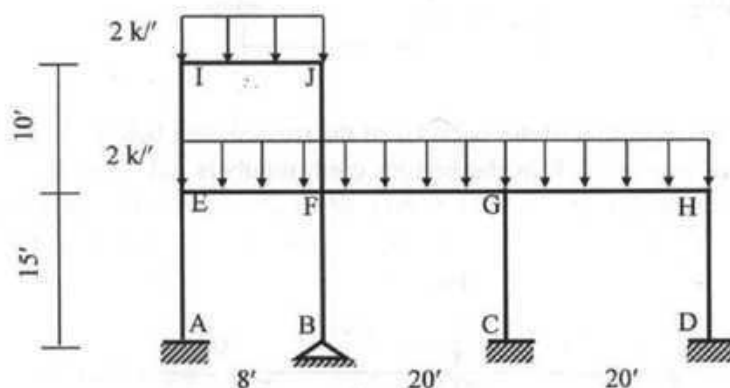

2. For the structure shown below, use the Cantilever Method to draw all the Column BMD and Beam BMD. The columns cross-sectional area is given in the parenthesis.

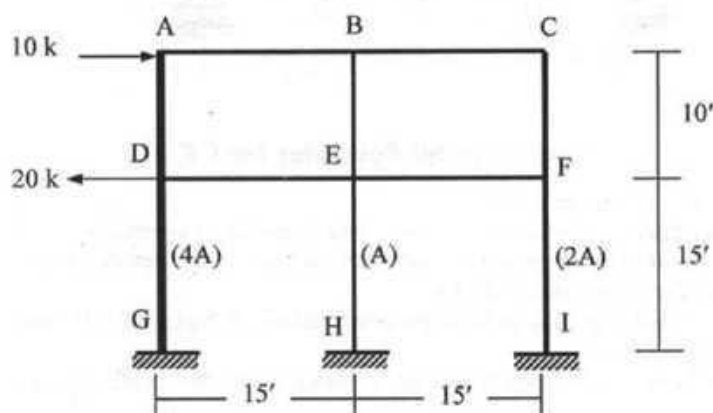

3. In the mill bent shown below,
- Use the Portal Method to draw the bending moment diagram of the column ABC.
  - Calculate the forces in GI and FH, assuming them to take equal share of the sectional shear.

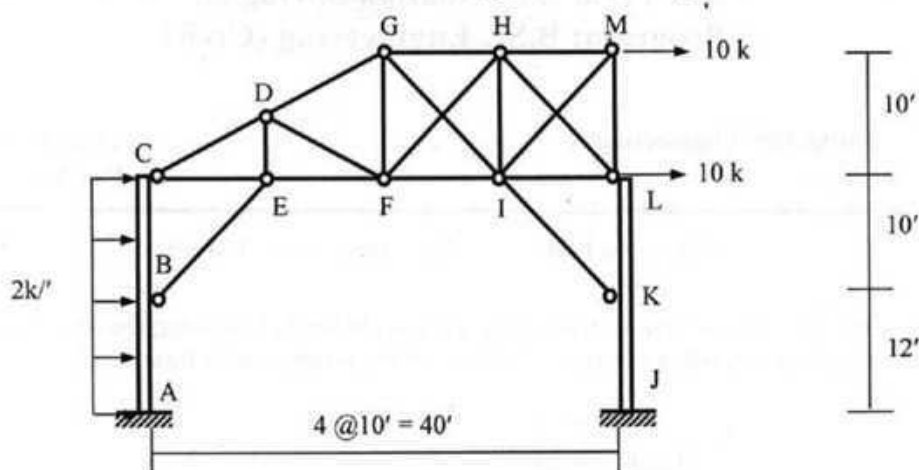

4. Calculate the vertical deflection of the point  $U_0$  of the truss shown below due to the external loads applied, temperature rise of  $30^\circ\text{F}$  in the bottom chord members  $L_0L_1$  and  $L_1L_2$  and a fabrication defects resulting in vertical members  $L_1U_1$  to be made  $0.25''$  shorter than specified.  
 [Given:  $\alpha = 5.5 \times 10^{-6}/^\circ\text{F}$ ,  $E = 29000\text{ksi}$  and the parenthesis value indicates area in  $\text{in}^2$ ].

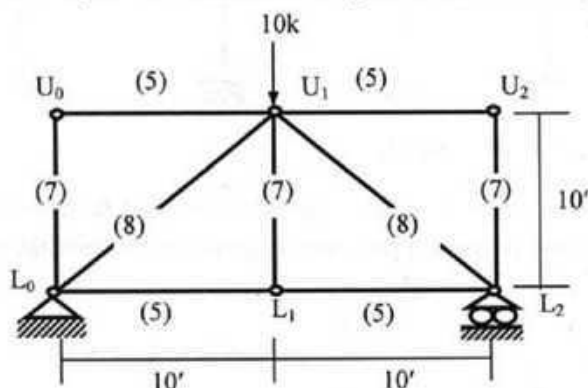

### List of Useful Formulae for CE 313

- \* Portal Method for multi-storied frames assumes
  - The shear force in an interior column is twice the shear force in an exterior column.
  - There is a point of inflection at the center of each column, and at the center of each beam.
- \* Cantilever Method is based on three assumptions
  - The axial force in each column of a story is proportional to its horizontal distance from the center of gravity of all the columns of the story.
  - There is a point of inflection at the center of each column, and at the center of each beam.
- \* Vertical Analysis based on approximate location of hinges
 
$$M_{(-)} = 0.08 wL^2, M_{(+)} = 0.045 wL^2, \quad V_{(+)} = wL/2, \text{ and } V_{(-)} = -wL/2$$
- \* Vertical Analysis using ACI Coefficients
  - $M_{(-)}$  (i) For end spans, if discontinuous end is (a) unrestrained =  $wL^2/11$ , (b) restrained =  $wL^2/14$
  - (ii) For interior spans =  $wL^2/16$
  - $M_{(+)}$  (i) At the exterior face of first interior supports for (a) Two spans =  $wL^2/9$ , (b) More spans =  $wL^2/10$
  - (ii) At the other faces of interior supports =  $wL^2/11$
  - (iii) For spans not exceeding  $10'$ , of where columns are much stiffer than beams =  $wL^2/12$
  - (iv) At the interior faces of exterior supports, if the support is (a) a beam =  $wL^2/24$ , (b) a column =  $wL^2/16$
  - $V$  (i) In end members at first interior support =  $\pm 1.15wL/2$ , (ii) At all other supports =  $\pm wL/2$
- \* Deflection of truss due to load, temperature change and misfit,  $\Delta = \sum N_1 dL = \sum N_1 (N_0L/EA + \alpha\Delta T L + \Delta L)$

**University of Asia Pacific**  
**Department of Civil Engineering**  
**Mid Semester Examination Spring 2012**  
**Program: B. Sc. Engineering (Civil)**

Course Title: Design of Reinforced Concrete Structures II  
 Time: 1 hour

Course Code: CE 315  
 Full Marks: 60

**Section-A [Answer any three (03) of the following five question]**

1. What do you mean by (i) singly reinforced and doubly reinforced beam, (ii) "over reinforced" and under reinforced beam" (06)
2. With reference to WSD method and singly reinforced beam explain the term 'balanced stress steel ratio'. Derive an expression for this ratio using the concept of linear strain distribution along beam depth. (06)
3. Why does the ACI recommend that in WSD, the value of compressive stress in steel ( $f_s$ ) be taken as twice the value calculated from elastic analysis? (06)
4. What is Whitney's stress block? Explain why it is used in USD. (06)
5. What are the load and resistance factors? Explain why they are used in USD. (06)

**Section-B [Answer any two (02) including question 6. Question 6 is Compulsory]**

6. The short beam of Fig.1 cantilevers from a supporting column. The beam carries dead load (including self wt.) and live load whose magnitude changes. Material strengths are ,  $f_c' = 3$  ksi,  $f_y = 60$  ksi,  $f_s = 24$  ksi ,  $f_t = 400$  psi and  $n=9$ .

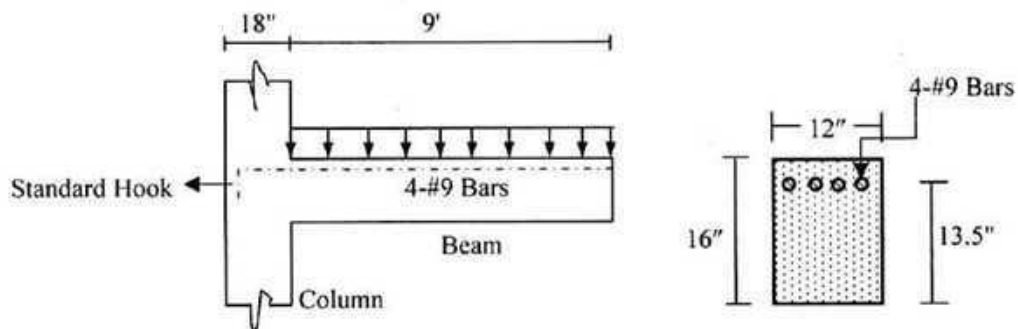

**Fig. 1**

- (a) Find the moment that will produce the first cracking at the top surface of the beam basing your calculation on  $I_g$ , the moment of inertia of the gross cross section. Repeat the calculation using  $I_{ut}$ , the moment of inertia of the uncracked transformed section. (08)
- (b) Determine the maximum moment that can be carried by the beam section of Fig.1 without stressing the concrete beyond  $0.45f_c'$  or the steel beyond  $0.4f_y$ . (06)
- (c) Calculate the nominal flexural strength and design strength to be used for design for the beam section shown in Fig. 1. (06)

7. A rectangular beam of width  $b=12"$  is limited by architectural considerations to a maximum total depth  $h=22"$ . It must carry a total factored load moment  $M_u=400$  k-ft. Design the flexural reinforcement for this member, using compression steel if necessary. Use USD method.

(22)

[Material strengths are,  $f_c' = 4$  ksi,  $f_y = 60$  ksi]

8. Refer to Fig. 2, Calculate moment capacity of the beam

(22)

i) by WSD method

ii) by USD method.

Given:  $f_c' = 3$  ksi,  $f_y = 60$  ksi,  $f_{sal} = 24$  ksi,  $f_{cal} = 1.35$  ksi and  $n=9$

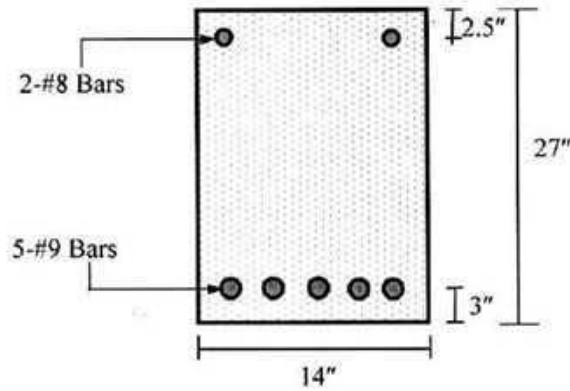

Fig. 2

**University of Asia Pacific**  
 CE 317 Design of Concrete Structures II  
 Mid-Term Examination, June-2012

Marks: 40

Time: 1hr.

**Answer all the questions**

1. What is a two-way (edge supported) slab? Discuss the differences between one way slabs and two-way slabs. Discuss the significance of the limitation laid by ACI for long span/short span should be less than 2 for two-way slab design. 4
2. Why are ties provided in columns? Write down the design procedures and rules for placing ties in tied columns according to ACI. Make sketches if necessary. 6
3. When and why are corner reinforcements used in two-way slabs? Give all the specifications of such reinforcements according to ACI. 5
4. For the two-way edge supported slabs ( $t = 6''$ ) shown in fig. 1 the coefficients for middle strip mid span and support moments are given. Design the slabs. Calculate the required reinforcements and show them in neat sketches ( Draw plan and sections showing the reinforcements). Floor Finish (FF) = 30 psf; Live Load (LL)= 80 psf.

Given:  $t = 6''$ ,  $f'_c = 3.0$  ksi,  $f_y = 60$  ksi;  $n = 9$ . 10

$+C_{A(DL)} = 0.027$ ,  $+C_{A(LL)} = 0.032$ ,  $-C_A = 0.071$ ,

$+C_{B(DL)} = 0.033$ ,  $+C_{B(LL)} = 0.035$ ,  $-C_B = 0.0$

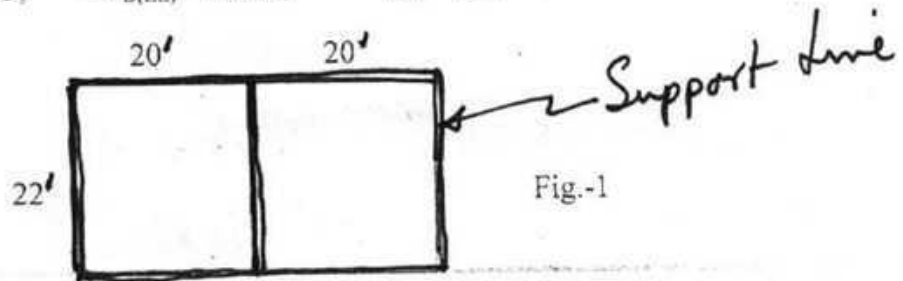

5. Design a Tied Column for a DL = 50 kip and LL = 20 kip  
 Given:  $f'_c = 3.0$  ksi,  $f_y = 60$  ksi;  $n = 9$ . 6

6. Show the ties as per ACI Code for the following column sections ( Fig. 2). All main Bars are 1" dia. 9

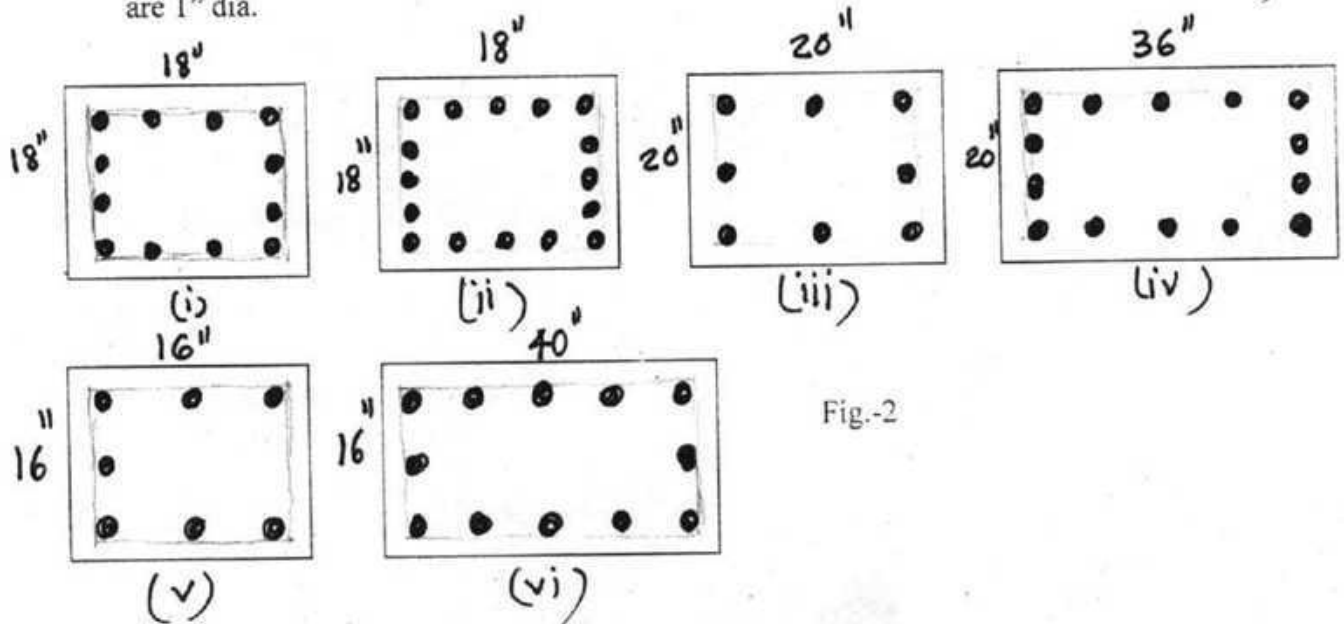

Fig. 2

**University of Asia Pacific,**  
**Department of Civil Engineering**  
**Mid Semester Examination Spring 2012**  
**Program: B. Sc. Engineering (Civil)**

Course Title: Environmental Engineering I  
Time- 1 hour

Course Code: CE 331  
Full marks: 60

**Answers all the questions below:**

1. (a) Show that the ground water yield of an confined aquifer , can be expressed as , (5)  
$$Q = \{2\pi km(D-d)\} / \{\log_e(R/r)\}$$
  
Where, Q= Well discharge  
K= Coefficient of permeability  
D = Depth of the aquifer  
d = Static head  
R = Radius of circle of influence  
r = Radius of the well  
m= Thickness of the confined water bearing stratum
- (b) Write down the problems of groundwater development in Bangladesh. Also discuss briefly (5)  
how the present situation in Bangladesh for freshwater scarcity can be minimized ?
- (c) What do you mean by  $D_{60}$  size of slot of a well screen ? Also discuss shortly the relation (5)  
between the grain size distribution curve for an aquifer and well screen for that aquifer.
- (d) Give the relation between the zone of saturation and unconfined aquifer (with figure). (4)
- (e) Write down the objectives of well development. (3)
- (f) Define: (5)  
Opening area of well screen, screen transmitting capacity.
2. Table shows the population of a country during the years 2000 - 2010, in ten years (10)  
intervals. (a) Find the equation of the least square parabola fitting the data. (b)  
Compute the trend values for the years in the table below and compare with the actual  
values. (c) Estimate the population of the community in the year 1980 and 1990.

Year	2000	2001	2002	2003	2004	2005	2006	2007	2008	2009	2010
Pop <sup>n</sup> (mill ion)	23	31	39	50	62	76	92	105	122	131	151

3. A fully penetrating well in a confined sandy aquifer has a maximum transmitting capacity of 1200 l/min. the aquifer is overlain and underlain by impervious formations. The thickness of the aquifer is 20 m. design the length of the well screen, assuming the percentage of open area in the available strainer to be 15% and bore hole dia as 15 cm. [Assume safe entrance velocity 2 cm/sec, since k for sands is usually 0.04 cm/sec] (6)
4. What fire flow and storage are required for fire protection (12 hour) in a city of 2,00,000 populations according to the recommendation of the National Board of the Fire Underwriters ? Also find out the quantity of water demand for per person for fire fighting in the city. (5)
5. Design a raw water pumping station (with figure) for obtaining water from a perennial river with the following data: (12)
- I. Population to be served = 5 lakhs
  - II. Daily demand for water = 150 liter per person per day ( average)
  - III. Summer requirements = 150 % of average
  - IV. Normal water level in river = R.L. 202.00 m
  - V. Low water level in river ( during summer) = R.L. 199.50m
  - VI. The water is to be pumped in two shifts of 10 hrs each daily and lifted to the inlet of water treatment plant situated nearby at R.L. 217.00m
  - VII. The losses due to friction in C.I. rising main of 0.9m dia are low due to its short length and can be assumed to be 2 meters in summer season and 1.2 meters on an average.
  - VIII. The efficiency of the pumps and the driving motors can be taken as 75% and 90% respectively.

**The necessary equations and data are given below:**

- I. Water Horse Power =  $(\gamma_w \cdot Q \cdot H) / 0.735$
- II. Brake Horse Power = Water Horse Power / (efficiency of pump) x (efficiency of motor)

**III. Fire Flow Required by The National Board of Fire Underwriters**

Population	Recommended fire flow, gpm
40,000	6,000
80,000	7,000
1,00,000	8,000
1,25,000	9,000
1,50,000	10,000
2,00,000	13,000

**University of Asia Pacific**  
**Department of Civil Engineering**  
**Mid Semester Examination Spring 2012**  
**Program: B.Sc. Engineering (Civil)**

Course Title: Environmental Engineering I      Course Code: CE 331      Credit: 2.00  
 Time- 1 hour      Full marks: 60

There are **FOUR** questions. Answers any **THREE**. ( $3 \times 20 = 60$ )

1. (a) What are the general considerations for planning a municipal water supply system? (8)
- (b) Table shows the number of students of University of Asia Pacific from 1990 to 2010, in two years intervals. (a) Find the equation of the least square parabola fitting the data. (b) Estimate the number of students in the year 2020 and 2016. (10)

Year	1990	1992	1994	1996	1998	2000	2002	2004	2006	2008	2010
Pop <sup>n</sup> (million)	23	31	39	50	62	76	92	105	122	131	151

- (c) Define flowing and non-flowing artesian well with respect to piezometric surface. (2)
2. (a) Write a short note on fire hydrants. (4+2)
- (b) A 100 mm diameter tubewell is sunk 35 m below static groundwater level. The probable discharge of the well is 33.4 lps. The radius of drawdown is 30 m and the coefficient of permeability of the aquifer is  $0.5 \text{ l/s/m}^2$ . Calculate the depth of water in the tubewell while pumping. (7)
- (c) If a similar well is constructed at a distance of 26 m from the well in question 2(b), determine how it will affect the discharge of the two wells. (5)
- (d) List the shortcomings of Tara handpump. (2)
3. (a) If the community you live in has a population of around 23000, can you identify/ calculate the fire demand of that locality using different formula? (5)
- (b) The population of a town was 180,000 in 1980 and 220,000 in 1990. What will the population be in 2000? (3)

- (c) Describe the hydrologic cycle with figure. (7)
- (d) Define confined and unconfined aquifer with figure. (5)
- 4. (a) Define the following terms: Coefficient of permeability, specific retention, porosity, storage coefficient. (6)
- (b) Describe different components of No.6 Handpump tubewell. (6)
- (c) Define well development. After construction, what should be done for maintenance of well? (6)
- (d) Name some methods for drilling deep tubewell. (2)

**University of Asia Pacific**  
**Department of Civil Engineering**  
**Mid Term Examination-Spring 2012**  
**Program: B.Sc. Engineering (Civil)**

Course No: CE 333  
 Course Title: Environmental Engineering II (Waste Water Engineering)

Time: 60 min  
 Full Marks: 60

[Answer all the questions]

[Assume reasonable value for missing data (if any)]

1. Design a septic tank for a family of 10 persons with a desludging interval of 6 years. (20)  
 The average wastewater flow is 90 litres per capita per day. Also design the soak pit for the disposal of septic tank effluent. The soil is silty loam with a long term infiltration rate of 20 l/m<sup>2</sup>-day. Draw neat sketches for septic tank and soak pit.
2. Determine the velocity in a 30 cm circular sewer with  $n = 0.013$ , slope  $S = 0.004$  (12)  
 m/m and depth of flow equal to 7.5 cm.
3. Define: (i) Sullage, (ii) Sewage, (iii) Gray water, (iv) Intercepting sewer. (6)
4. Show diagrammatically the effect of sanitation on disease transmission. (6)
5. What are salient features of Hydraulic Element Diagram? (6)
6. Enumerate different sewer section. Why circular section is preferred for sewer? (6)
7. What is the significance of the following graph representing typical hourly variation (4)  
 in residential area?

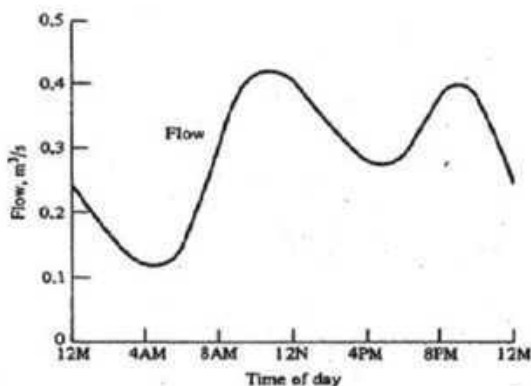

**Formulae**

$$V_{sc} = 0.4 V_{sl}$$

$$t_d = 30 * (1.035)^{35-T}$$

$$V_d = 0.5 * 10^{-3} P t_d$$

$$d_{sc} = 0.82 - 0.26A$$

$$V_h = 10^{-3} P q t_h$$

$$t_h = 1.5 - 0.3 \log (Pq)$$

$$V_{sl} = C P N$$

$$V_p = 1.486/n * R^{2/3} S^{1/2}$$

**University of Asia Pacific**  
**Department of Civil Engineering**  
**Mid Term Examination-Spring 2012**  
**Program: B.Sc. Engineering (Civil)**

Course No: CE 333  
 Course Title: Environmental Engineering II (Waste Water Engineering)

Time: 60 min  
 Full Marks: 60

[Answer all the questions]

[Assume reasonable value for missing data (if any)]

1. Design a septic tank for a family of 15 persons with a desludging interval of 4 years. (20)  
 The average wastewater flow is 85 litres per capita per day. Also design the soak pit for the disposal of septic tank effluent. The soil is silty loam with a long term infiltration rate of 30 l/m<sup>2</sup>-day. Draw neat sketches for septic tank and soak pit.
2. Determine the velocity in a 40 cm circular sewer with  $n = 0.015$ , slope  $S = 0.005$  (12)  
 m/m and depth of flow equal to 10 cm.
3. Define: (i) Sewer, (ii) Sewerage, (iii) Black water and (iv) Trunk sewer (6)
4. Draw the disease transmission route (without the effect of sanitation). (6)
5. What is the suitable sewerage system in Old Dhaka? Justify your answer. (6)
6. What are the causes of crown corrosion in concrete sewer? Suggest some measures. (6)
7. What is the significance of the following graph representing sewage flow variation with respect to water supply? (4)

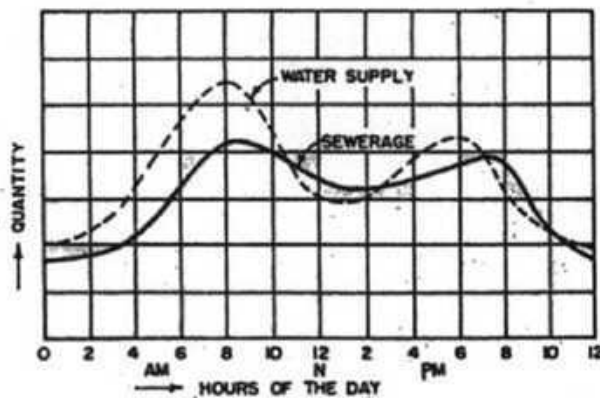

**Formulae**

$$V_{sc} = 0.4 V_{sl}$$

$$t_d = 30 * (1.035)^{35-T}$$

$$V_d = 0.5 * 10^{-3} P t_d$$

$$d_{sc} = 0.82 - 0.26A$$

$$V_h = 10^{-3} P q t_h$$

$$t_h = 1.5 - 0.3 \log (Pq)$$

$$V_{sl} = C P N$$

$$V_p = 1.486/n * R^{2/3} S^{1/2}$$

**University of Asia Pacific**  
**Department of Civil Engineering**  
**MidTerm Examination Spring 2012**  
**Program: B.Sc. Engineering (Civil)**

**Course Title:** Geotechnical Engineering I  
**Time:** 1 hour

**Course Code:** CE 341  
**Full Marks:** 20

---

**There are 5 questions. Answer any 4 of the following questions. (4x5=20 marks)**

- |  |     |
|--|-----|
| 1. a) Define: (i) Effective Size, (ii) Uniformity Coefficient  | 2   |
| b) How can you identify organic soils?   | 1.5 |
| c) What are the different steps of soil formation?   | 1.5 |
| 2. a) Define: (i) Residual soil, (ii) Transported soil   | 2   |
| b) Discuss on the accumulation, characteristics and stability of a horizon, which is moderately weathered. | 3   |
| 3. a) Write short notes on: (i) Soil Profile and Soil strata, (ii) Weathering process                      | 3   |
| b) Draw three-phase diagrams of soil aggregates at partially saturated and fully saturated conditions.     | 2   |
| 4. a) What is the basis of distinguishing silt from clay?  | 1   |
| b) What do the results of sieve analysis indicate?   | 1.5 |
| c) What are the different soil structures for fine grained and coarse grained soils?                       | 2.5 |
| 5. a) Name four identification tests of fine grained soil.   | 1   |
| b) Discuss on the particle sizes of well graded, uniformly graded and gap graded soils.                    | 1   |
| c) Draw particle-size distribution curves for well graded and gap graded soils.                            | 3   |

**The University of Asia Pacific**  
**Department of Civil Engineering**  
**Mid Semester Examination Spring 2012**

Course No.: CE 351  
 Full Marks: 60 (15x4)

Course Title: Transportation Engineering I  
 Time: 1 hour

Answer any **ALL** four.

1. Draw the diagrams for the speed-flow-density relationships. A study of freeway flow at a particular site resulted in a calibrated speed-density relationship of  $S = 61.2e^{-0.015D}$ . For this relationship, determine the: free flow speed, jam density, speed flow relationship, flow density relationship and capacity.
2. A vertical curve is to be designed to connect a -4% grade to a +1% grade on a facility with a design speed of 70 mph. For economic reasons a minimum-length curve will be setup. The V.P.I of the station is at 5100+22 and has an elevation of 210 ft. Find the station and elevation of the V.P.C and V.P.T, the high point of the curve and at 100-ft intervals along the curve.
3. What length of super elevation run off should be used to achieve a super elevation of 10%? The design speed is 70 mph and a three lane cross section (standard lane width) is under consideration. Super elevation will be achieved by rotating all three lanes around the inside edge of the pavement.
4. Drivers must slow down from 70 mph to 60 mph to negotiate a severe curve on a rural highway. A warning sign is clearly visible for a distance of 100 ft. How far of the curve must the sign be located in order to ensure that vehicles have sufficient distance to safely decelerate? In and when standard values are required, follow the AASHTO standard. What does AASHTO stand for?

**Table 3.3: Maximum Relative Gradients ( $\Delta$ ) for Superelevation Runoff**

Design Speed (mi/h)	Maximum Relative Gradient (%)	Design Speed (mi/h)	Maximum Relative Gradient (%)
15	0.78	50	0.50
20	0.74	55	0.47
25	0.70	60	0.45
30	0.66	65	0.43
35	0.62	70	0.40
40	0.58	75	0.38
45	0.54	80	0.35

**University of Asia Pacific**  
**Spring 2012 Midterm Examination**

**CE 361 (Open Channel Flow)**  
**Total Marks: 30, Time: 1 hour 10 minutes (70 minutes)**

**[Answer all the questions]**

1. (a) Define: (1) Prismatic and Non-prismatic channel, (3)  
(2) Steady and unsteady flow (3)  
(b) Explain when hydrostatic pressure distribution is valid in open channel flow. (2)  
(c) Water flows in an open channel at a depth of 1 m and a mean velocity 3 m/sec.  
Compute the discharge and determine the state of flow if the channel is trapezoidal with  
bottom width,  $b = 6$  m and side slope,  $s = 2$ . (5)
  
2. (a) Write down Bernoulli's energy equation. What are the external forces acting in  
developing momentum equation? (3)  
(b) What is difference between "Specific Energy" and "Total Energy"? Draw Specific  
Energy diagram and show its different components. (2+2)  
(c) Prove that for a rectangular channel at critical section  $E_c = 1.5 h_c$  (3)
  
3. (a) Derive the formula for energy coefficient  $\alpha$ . (3)  
(b) Define 'section factor' and 'critical flow'. (3)  
(c) Prove that at critical section, Froude Number,  $F_r = 1$ . (4)

**The University of Asia Pacific**  
**Department of Civil Engineering**  
**Mid Semester Examination Spring 2012**

Course # : CE 363  
 Full Marks:60

Course Title: Engineering Hydrology  
 Time: 1 hours

**Answer all question**

1. Describe the importance and engineering relevance of hydrology. (5)
2. Define the following:
  - i) Lapse rate (2)
  - ii) Cold and Warm Front (3)
  - iii) Intensity – Duration – Frequency relationship (4)
  - iv) Dalton's Law (2)
  - v) Horton's equation for infiltration (3)

3. For a drainage catchment of 600 km<sup>2</sup>, isohyets drawn for a storm gave the following data: (12)

Isohyets intervals (cm)	15-12	12-9	9-6	6-3	3-1
Inter-isohyetal area (km <sup>2</sup> )	92	128	120	175	85

Estimate the average depth of precipitation over the catchment.

4. List different factors affect the evaporation rate from a water body. (6)
5. What are the different methods of base flow separation from a natural hydrograph? (3)
6. Given below are the ordinates of a 6h unit hydrograph for a catchment. Calculate the ordinates of the DHR due to a rainfall excess of 3.5 cm occurring in 6h. (10)

Time (h)	0	3	6	9	12	15	18	24	30
UH ordinate (m <sup>3</sup> /s)	0	25	50	85	125	160	185	160	110

Time (h)	36	42	48	54	60	69
UH ordinate (m <sup>3</sup> /s)	60	36	25	16	8	0

7. Distinguish between: (5x2=10)
  - a) Actual and potential evapotranspiration
  - b) Field capacity and permanent wilting point

**University of Asia Pacific**  
**Department of Civil Engineering**  
**Mid Term Examination Spring 2012**  
**Program : B.Sc Engineering (Civil)**

Course Title: Project Planning and Management  
Time: 1:00 hrs

Course Code: CE 401  
Full Marks: 20

There are THREE Questions answer any TWO  
(Graph sheet should be supplied)

1. (a) What are the major characteristics of a project? Discuss Project life cycle in detail. (3)
- (b) The Farmer's American Bank of Leesburg is planning to install a new computerized accounts system. Bank management has determined the activities required to complete the project, the precedence relationships of the activities are as follows: (07)

Activity	Activity Predecessor	Time (Weeks)
1	-----	3
2	1	2
3	1	5
4	1	4
5	2	3
6	3	2
7	4	8
8	5,6	4
9	8	4
10	7	4
11	9,10	7

- A. Draw the AON network diagram  
B. Find the project completion time  
C. Find the critical path  
D. Find ES/EF and LS/LF for each of the activity  
E. If you reduce the time required for activity 8 & 10 by 1 week each, find the project completion time and critical path as well.

2. (a) Objective function: (7)

$$\text{Maximize } Z = 5x_1 + 4x_2$$

Constrains:

$$6x_1 + 4x_2 \leq 24$$

$$x_2 \leq 2$$

$$x_1 + 2x_2 \leq 6$$

$$-x_1 + x_2 \leq 1$$

$$x_1, x_2 \geq 0$$

- i. Find the feasible area by Graphical Method
- ii. Find the optimum value of  $x_1$  and  $x_2$ .
- iii. Find maximum profit
- iv. Find the range of optimality for  $x_1$  and  $x_2$  separately.

(b) A firm manufactures three products A, B and C. The profits are Tk. 3, Tk. 2 and Tk. 4 respectively. The firm has two machines and the required processing time in minutes for each machine on each product is given below: (3)

		Product		
		A	B	C
Machine	C1	4	3	5
	D1	2	2	4

Machine C1 and D1 have 2000 and 2500 machine-times respectively. The firm must manufacture 100 A's, 200 B's and 50 C's but no more than 150 A's. Formulate Linear Programming Model.

3. (a) Solve the following problem by Simplex Method (7)

Maximize  $G = 10x + 6y + 4z$   
Subject to  $x + y + z \leq 100$   
 $10x + 4y + 5z \leq 600$   
 $2x + 2y + 6z \leq 300$   
 $x, y, z \geq 0$

(b) Discuss the differences between NPV & IRR and Pay-Back Period & Discounted Pay-Back Period with appropriate examples. (3)

**The University of Asia Pacific**  
**Department of Civil Engineering**  
**Mid Semester Examination, Spring 2012 (Set A)**

Course#: CE 411  
 Full Marks: 30 (= 3 x 10)

Course Title: Structural Engineering III  
 Time: 1 hour

Answer **any Three (3)** from the following Four questions

1. Ignoring zero-force members, formulate the stiffness matrix, load vector and calculate the deflections (in X-, Y- and Z-directions) at joint E of the space truss ABCDEF loaded as shown below (with nodal coordinates) [Given:  $S_x = \text{constant} = 500 \text{ k/ft}$ ].

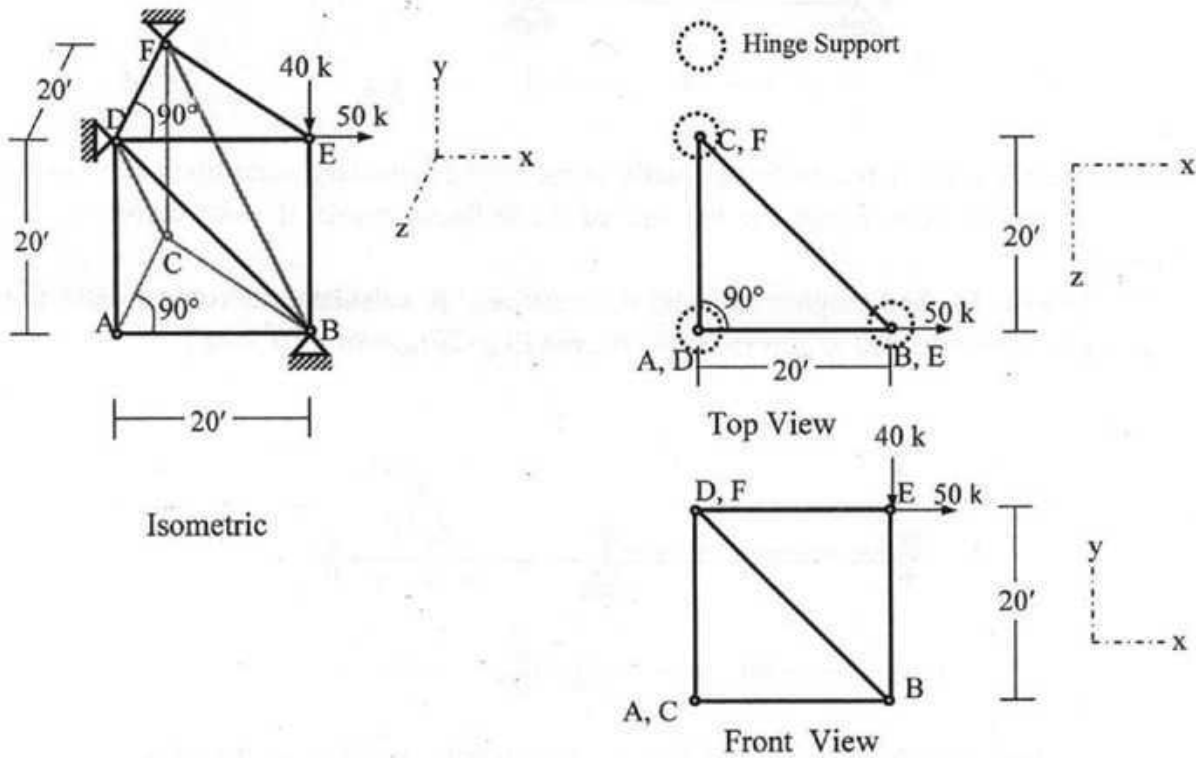

Nodal Coordinates

A (0, 0, 0), B (20, 0, 0), C (0, 0, -20), D (0, 20, 0), E (20, 20, 0), F (0, 20, -20)

2. Use the stiffness method to calculate the horizontal and vertical deflection at joint  $c$  for the truss shown below. ( $S_x = \text{constant} = 500 \text{ k/ft}$ )

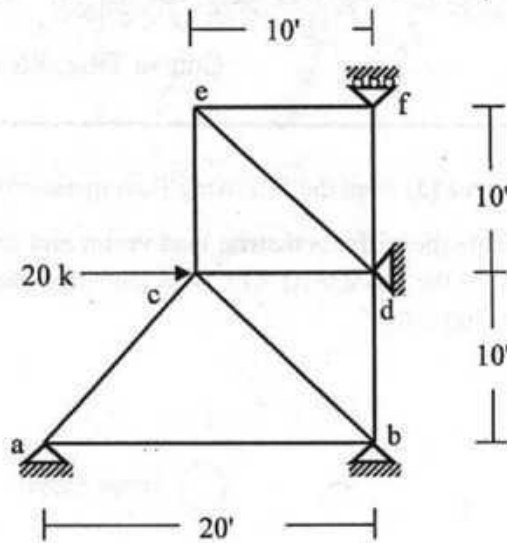

3. Determine the size of the stiffness matrix (considering boundary conditions also) of beam  $abcd$  shown below. Also determine the size of the stiffness matrix if axial deformations are neglected.

Use the Stiffness Method (neglecting axial deformations) to calculate the vertical deflection at joint  $a$  of the beam if loaded as shown below [Given  $EI_{ab} = 2EI_{bcd} = 80 \times 10^3 \text{ k-ft}^2$ ]

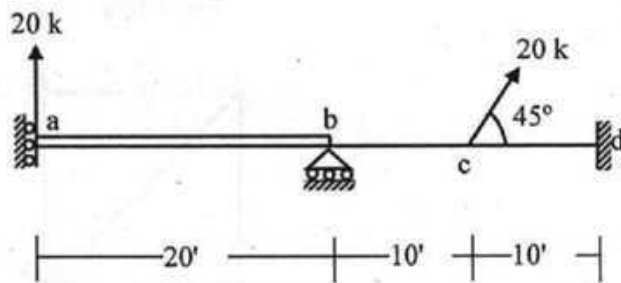

4. Use the Stiffness Method (with flexural deformations only) to calculate the rotations at joint  $B$  and joint  $C$  of the frame loaded as shown below [Given:  $EI = \text{constant} = 40 \times 10^3 \text{ k-ft}^2$ ]

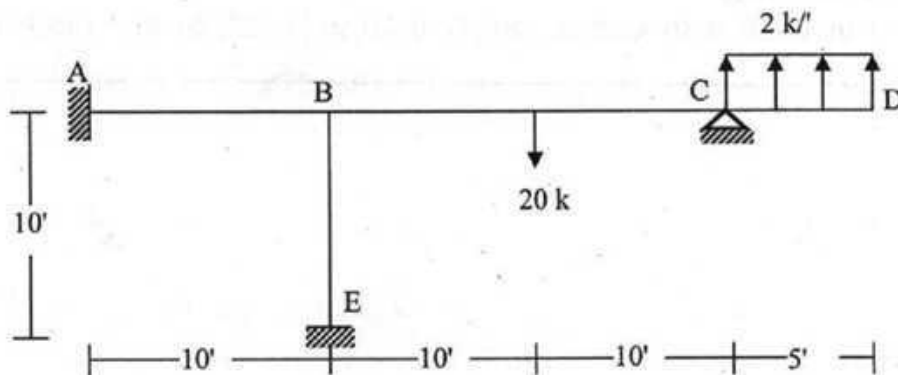

**The University of Asia Pacific**  
**Department of Civil Engineering**  
**Mid Semester Examination, Spring 2012 (Set B)**

Course#: CE 411  
 Full Marks: 30 (= 3 x 10)

Course Title: Structural Engineering III  
 Time: 1 hour

Answer **any Three (3)** from the following Four questions

1. Ignoring zero-force members, formulate the stiffness matrix, load vector and calculate the deflections (in  $X$ -,  $Y$ - and  $Z$ -directions) at joint E of the space truss ABCDEF loaded as shown below (with nodal coordinates) [Given:  $S_x = \text{constant} = 500 \text{ k/ft}$ ].

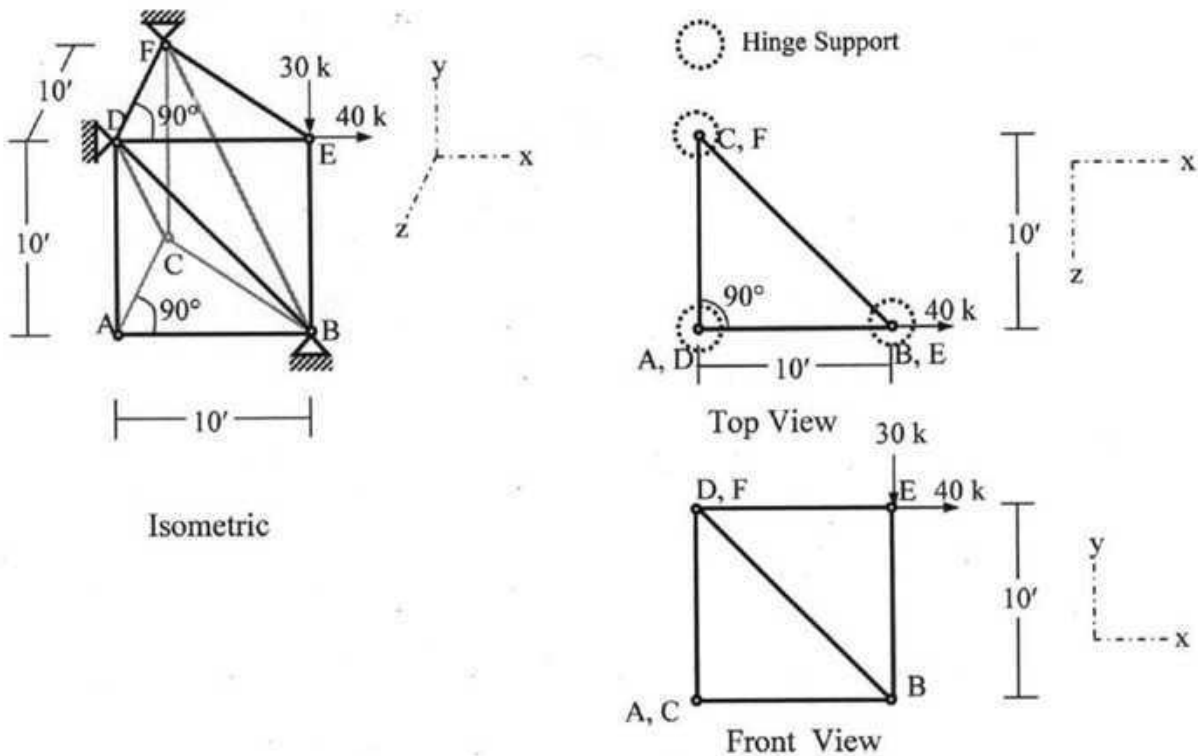

Nodal Coordinates

A (0, 0, 0), B (10, 0, 0), C (0, 0, -10), D (0, 10, 0), E (10, 10, 0), F (0, 10, -10)

2. Use the stiffness method to calculate the horizontal and vertical deflection at joint *c* for the truss shown below. ( $S_x = \text{constant} = 500 \text{ k/ft}$ )

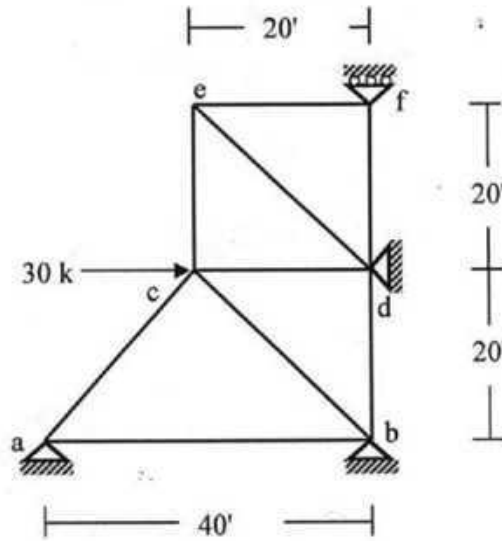

3. Determine the size of the stiffness matrix (considering boundary conditions also) of beam *abcd* shown below. Also determine the size of the stiffness matrix if axial deformations are neglected.

Use the Stiffness Method (neglecting axial deformations) to calculate the vertical deflection at joint *a* of the beam if loaded as shown below [Given  $EI_{ab} = 2EI_{bcd} = 80 \times 10^3 \text{ k-ft}^2$ ]

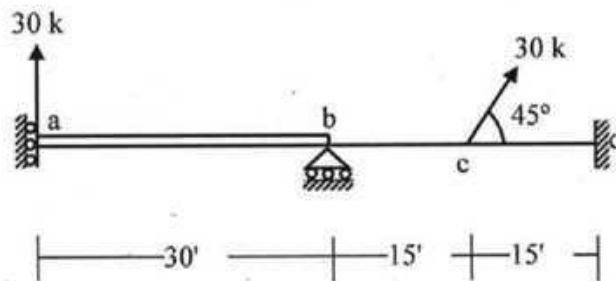

4. Use the Stiffness Method (with flexural deformations only) to calculate the rotations at joint *B* and joint *C* of the frame loaded as shown below [Given:  $EI = \text{constant} = 40 \times 10^3 \text{ k-ft}^2$ ]

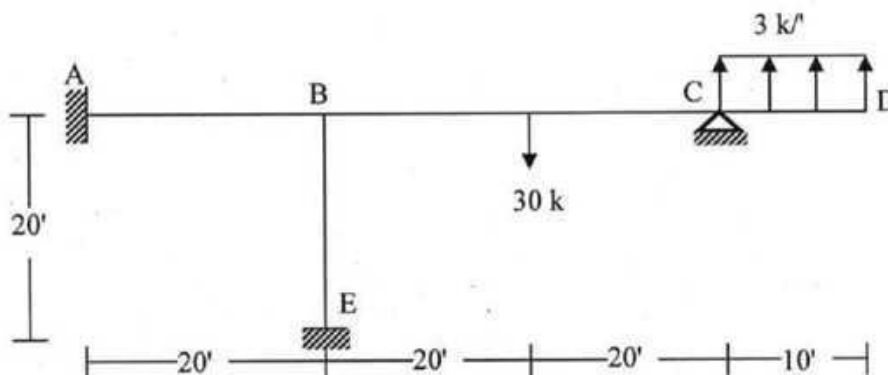

**University of Asia Pacific**  
**Department of Civil Engineering**  
**Mid Semester Examination Spring 2012**

Course # CE 415  
 Full Marks: 30

Course Title: Structural Engineering v  
 Time: 1 hr

There are FOUR questions. Answer any **THREE**.  
 Each question carries equal number.

1. A prestressed-concrete rectangular beam of 500mm by 750mm has a simple span of 7.3m and is loaded by a uniform load of 45 kN/m excluding self-weight. The effective prestress is 1550 kN. Compute the fiber stress in concrete at section 1-1 using 2<sup>nd</sup> concept.

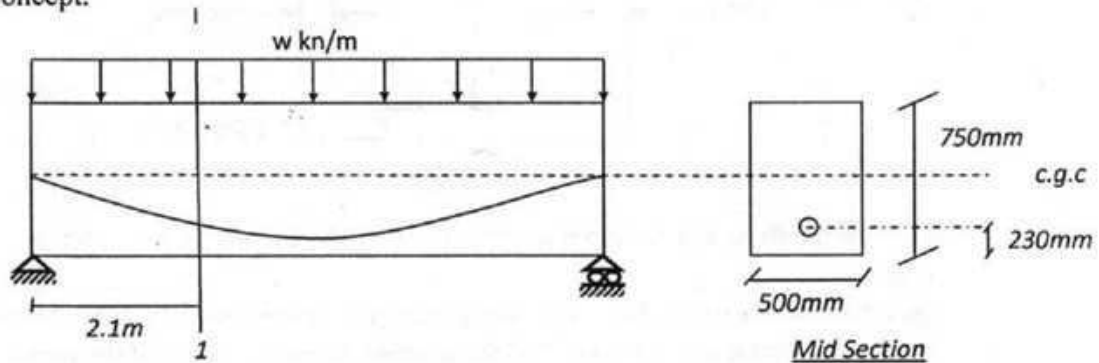

2. A pretensioned concrete member has a simple span of 12m and is prestressed with 820 mm<sup>2</sup> wires which are anchored to the bulkhead to with an initial stress of 1050 MPa. If  $E_{ci}=33000$ MPa  $E_s=200000$  MPa. Compute the stress in steel at section 1-1 after elastic shortening of concrete. (Hints: Consider bending, eccentricity and axial shortening)

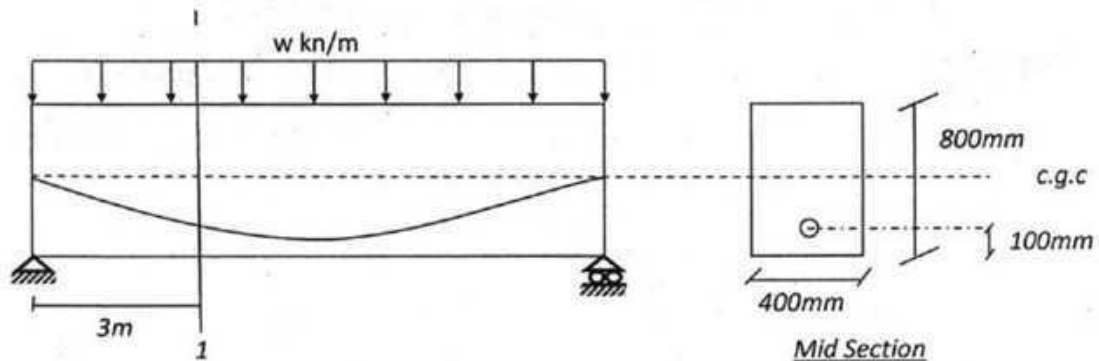

3. A posttensioned simple beam of 12m span has a cross section as shown in figure below. Calculate the total dead load and live load that can be carried by the beam (1) for zero tensile stress in bottom fibers (2) For cracking in the bottom fibers at a modulus of rupture of 4.2 MPa.

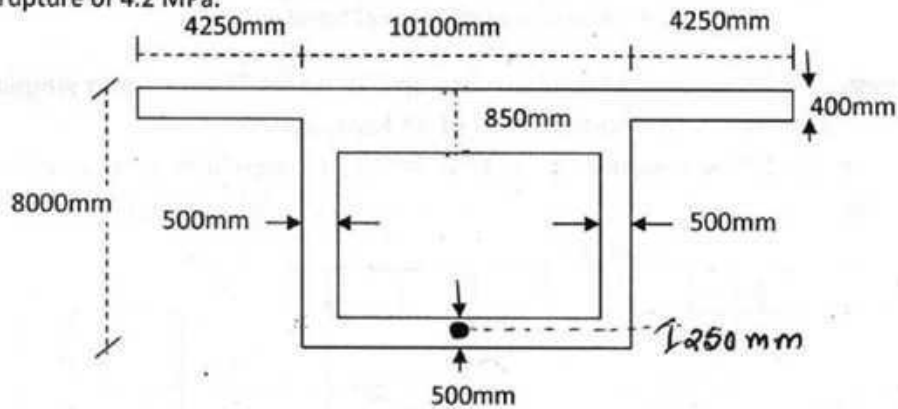

4. (a) Draw the stress distribution diagram in P.C. for different position of C according to elastic theory.  
 (b) A T-shaped beam is prestressed with  $1600\text{mm}^2$  steel with an initial stress 1100 MPa. Assuming 10% loss in prestress find the ultimate moment capacity of the section for design following the ACI code. Given:  $f_{pu}=1860\text{ MPa}$ ,  $f_c=48\text{MPa}$

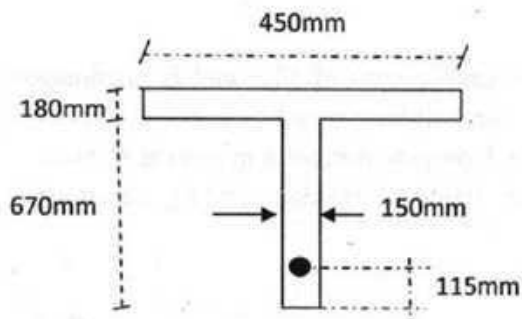

Formula:

$$f_{ps} = f_{pu} \left( 1 - 0.5 \rho_p \frac{f_{pu}}{f_c} \right)$$

$$a = \frac{A_{ps} f_{ps}}{0.85 f_c b}$$

$$\omega = \rho_p \frac{f_{ps}}{f_c}$$

$$M_u = \phi A_{ps} f_{ps} \left( d - \frac{a}{2} \right)$$

**The University of Asia Pacific**  
**Department of Civil Engineering**  
**Mid-term Examination Spring' 2012**

Course No. & Title: CE 417 Structural Engineering VI (Design of Steel Structures)

Full Marks: 20                      Time: 1 hour

The figures in the margin indicate full marks.

Notations convey their usual meanings. Assume reasonable values for any missing data.

**There are FOUR questions. Answer any THREE questions.**

1. (a) What do you understand by ductility of steel? 2  
(b) Explain why both ductility and strength contribute to toughness of steel? 2  
(c) Name & characterize the types of bolted joints in steel structures. 2  $\frac{2}{3}$
  
2. With a minimum overlap, design and detail the welded end connection (Fig. 1) required to transmit a dead load force of 60 kips and a live load force of 200 kips through a C12x25 with a web thickness of 0.387 inch to a  $\frac{3}{4}$ -inch gusset plate. All material is A36. Welds are to be deposited manually using E70XX electrode. AISC specified minimum weld size for the given case is  $\frac{1}{4}$ -inch. Allowable stress is 0.3 times the nominal tensile strength of weld metal. Use ASD method. 6  $\frac{2}{3}$

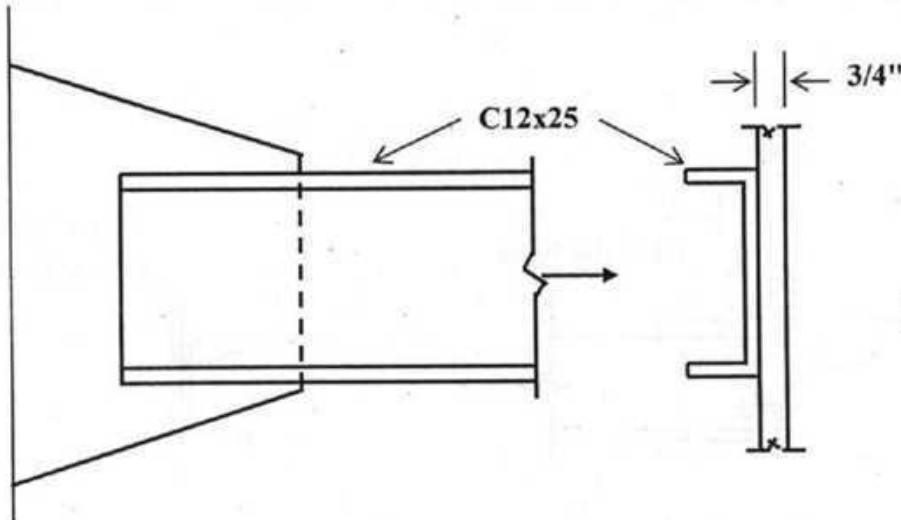

**Fig. 1**

3. A joint is designed with two lines of bolts to transmit a load through two L7x4x5/8 to a  $\frac{3}{4}$ -in. gusset plate (Fig. 2). All material is A36 and the bolts are  $\frac{3}{4}$ -in. A325 (Standard holes) in a bearing-type connection with threads excluded from shear planes. Using AISC/ASD method, determine the capacity of this joint by checking (i) shear in the bolts and (ii) bearing in the angles and gusset plate. The capacity of the tension member is not required to be checked. Given: Allowable stress in shear for bolts with no thread in shear planes = 30 ksi; Allowable stress in bearing =  $1.2 F_u$ . 6  $\frac{2}{3}$

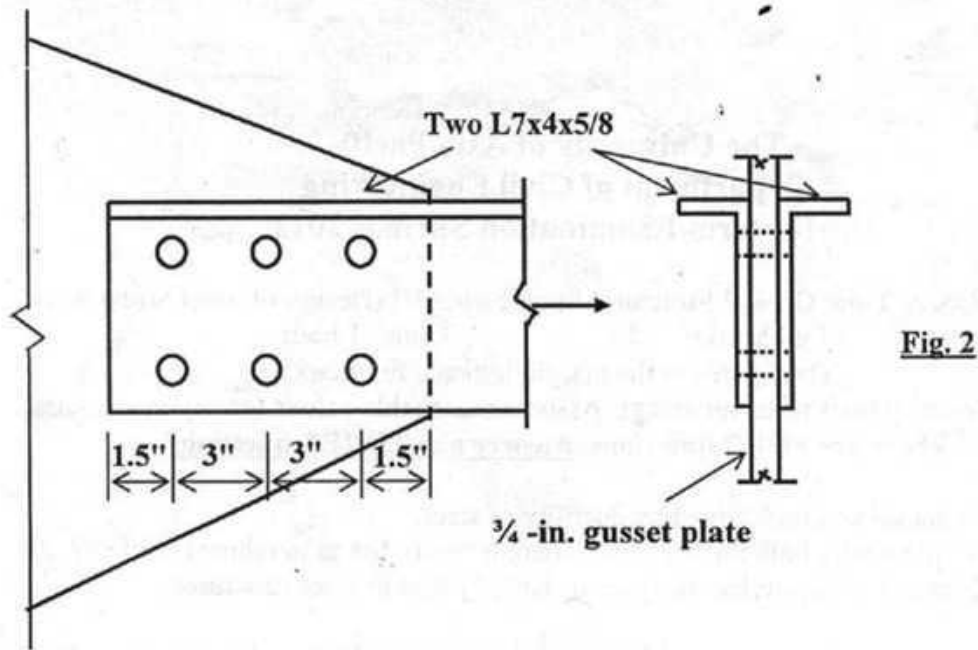

4. The 4" leg of an angle L4x3x1/4 is connected to a 6" wide and 3/8" thick gusset plate using two lines of 1/2" diameter bolts as shown in Fig. 3. Using AISC/LRFD method, determine the design strength of the angle in axial tension. Also determine the design tensile strength of the gusset plate. Bolt shear, bolt bearing, plate tearing or block shear is not required to be checked. All material is A242 steel with  $F_y=50$  ksi and  $F_u=70$  ksi. Given:  $U=0.75$ ,  $A_g=1.69$  in<sup>2</sup> for the angle.

6 3/8

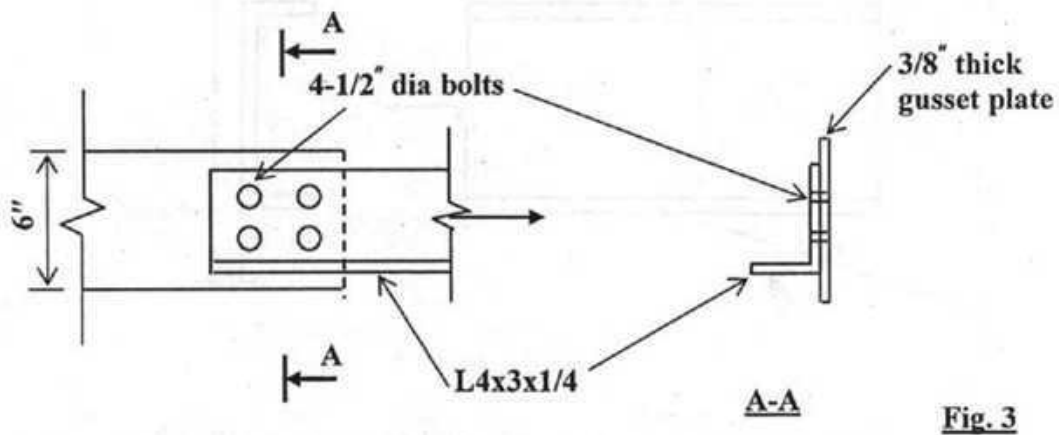

**Department of Civil Engineering**  
**Mid Semester Examination Spring 2012**  
**Program: B. Sc. Engineering (Civil)**

Course Title: Environmental Engineering III  
 Time- 1 hour

Course Code: CE 431  
 Full marks: 60

Answers all the questions below:

1. (a) Describes the diagram of recycling and resources recovery system in urban centers. (5)
- (b) What is capacity margin ? A small city of 25,000 population of having 0.4 kg/cap/day municipal solid waste generation rate. The waste collection crews collect the wastes twice a day in a week. Find out the size of the storage container using the following equation: (2+6)

Size of storage container =  $(N \times G \times F) / D + \text{capacity margin.}$

Where, N= no. of population ( nos, cap)

G = average rate of waste generation( kg/ cap/ day)

F = weekly frequency of collection

D= density ( kg/ m<sup>3</sup>) = 600 kg/ m<sup>3</sup> (avg)

2. (a) Describe what kind of practices for source reduction are involved in Bangladesh and Canada (for dry recyclable materials, biodegradable materials and hazardous materials) and how the MSW are stored for collection by the external actors in each home, apartment in those countries and in what systems these wastes are collected before disposal and which department are usually responsible for the collection system specially in Dhaka city ? (12)
- (b) Find out the effect of home recovery on energy content of collected solid wastes. (15)  
 Using the typical percentage distribution data given in the table below, estimate the energy of the remaining solid wastes if 80% of the cardboard, 80% of paper and 80% of yard wastes are recovered by the home owner, also analysis the effect of home recovery on energy content of collected solid waste if 80% paper is not recovered in the first situation.

Component	Weight (%)	Component	Weight (%)
Food waste	32.5	PVC	0.5
Paper ( mixed)	35	Leather shoe	0.5
News print	5	Textiles	3
Cardboard	4	Yard waste	13
Rubber	0.5	wood	3
Plastics	3		

[Type text]

- (c) Do an economic analysis and also give an economic decision about what size truck makes sense for the following job. (20)

Solid wastes from Mirpur area to be collected using a stationary container collection system having 5 cubic meter containers. Suppose the annualized cost of purchasing, fueling and maintaining a compactor truck is given by the following expression:

$$\text{Annualized cost (\$/yr)} = \alpha + \beta V$$

Where,  $\alpha$  and  $\beta$  are empirically determined which values are 25000 and 4000 respectively.  $V$  is the volume of truck in cubic yards.

The following conditions may be need for the analysis:

- Trucks require two person crews, with labor charged at 24\$ per hour ( including benefits)
- The truck collects waste from 340 households each day.
- Each household generates 60lb of wastes per week.
- The trucks and crew work 5 days per week and alley pick up is provided once a week for each house.
- Container utilization factor = 0.70
- Average number of containers at each location = 1
- Collection - vehicle compaction ratio= 2.5
- Container unloading time= 0.15 h/ container
- Average drive time between container location= 0.15 h
- One way haul distance= 35 km
- Speed limit= 72 km/hr
- Time from garage to first container location= 0.25 h
- Time from garage to last container location= 0.35 h
- Number of trips to disposal site per day= 2
- Length of working day= 8h

$$(0.03704 \text{ cu yd} = 0.02832 \text{ m}^3)$$

**Table 4.2: Typical data for computing equipment and labour requirements for hauled- and stationary-container collection**

Vehicle	Collection		Pick up loaded container and deposit empty container, h/trip	Empty contents of loaded container, h/containers	Average time, h/trip
	Loading method	Compaction ratio, $\lambda$			
Hauled container (Tilt-frame)	Mechanical	2.0-4.0	0.50		0.129
Stationary container (Compactor)	Mechanical	2.0-4.0		0.050	0.15

[Type text]

**Table 4.1: Typical values for haul constant coefficients m and n**

Type of haul	Speed limit	m	n
	km/h	h/trip	h/km
Communal	88	0.016	0.011
Block	72	0.022	0.014
Kerbside	56	0.034	0.018
Door-to-door	40	0.050	0.025

Adapted from: Peavy et al., 1985

**Table 3.5: capacity margin of storage container.**

Collection	Excess capacity required (%)		
	Individual	Communal	
		Attended	Unattended
Days per week			
6	66	66	100
7	33	33	50

Source: Habitat

**Table 2.10: Ultimate analysis of solid waste (per cent by weight in dry basis)**

Component	Carbon (C)	Hydrogen (H)	Oxygen (O)	Nitrogen (N)	Sulphur (S)	Ash (A)
Food waste	49.1	6.6	37.6	1.7	0.2	4.8
Paper (mixed)	43.4	5.8	44.3	0.3	0.2	6.1
Newsprint	49.1	6.1	43.0	0.1	0.2	1.5
Cardboard	44.0	5.9	44.6	0.3	0.2	5.0
Rubber	77.8	10.4	-	-	2.0	9.8
Plastics	60.0	7.0	23.0	-	-	10.0
PVC	45.2	5.6	1.6	0.1	0.1	47.4
Leather shoes	42.0	5.3	22.8	6.0	1.0	22.9
Textiles	55.0	6.5	31.2	4.5	0.2	2.6
Yard waste	48.7	6.3	37.9	3.0	0.3	3.8
Wood	50.5	6.0	42.4	0.2	0.1	0.8

Source: adapted in part from Kaiser (1978)

[Type text]

---

**University of Asia Pacific**  
**Department of Civil Engineering**  
**Final Examination Spring 2012**  
**Program: B.Sc. Engineering (Civil)**

Course Title: Environmental Engineering IV  
Time: 2 Hours

Course No. CE 433  
Full Marks: 135

---

Answer ANY THREE of the following Four Questions

- 1(a). A power plant discharges 4.50 kg of SO<sub>2</sub> per minute through a stack, which has an effective height of 60 meters. The wind velocity at a height of 10 m is 4.0 m/sec, and the atmosphere is "slightly unstable". Compute ground level concentration SO<sub>2</sub>: 26
- (i) At 1.25 km down-wind, along the centre-line of the plume, and  
(ii) At 1.25 km down-wind and 100 m off the center-line of the plume.  
(Given:  $p = 0.15$ ; Table for calculation of dispersion coefficient provided)
- (b). What do you understand by aerodynamic diameter of particulate matter (PM)? Why particulates of anthropogenic origin are considered more harmful, compared to particulates of natural origin? Explain. 11
- (c) Write down the names of the devices that are available for control of particulate contaminants from industrial sources? Briefly explain the working principle of a "gravitational settling chamber". 8
2. (a) A road has 10 cars passing a given point per minute, and each car on an average emits 9.5 g/km of carbon monoxide (CO). Wind is blowing at 2.0 m/sec perpendicular to the road and the atmosphere is "neutral". A building 20 m high is located 200 m down-wind of the road. Estimate CO concentration at the ground floor and the roof of the building. (Table for calculation of dispersion coefficient provided). 21
- (b). Starting from the combustion of sulfur (S) containing fuel, briefly explain the process of formation of sulfate (SO<sub>4</sub>) particles in the atmosphere. How do SO<sub>x</sub> affect building materials? Explain. 11
- (c). List the common options for control of vehicular air pollution. Briefly explain the working principles of (i) Thermal Reactor, and (ii) Exhaust Gas Recirculation. 13
- 3(a). What is AQI? What are its purposes? 18
- On a particular day, air quality data recorded at a CAMS in Dhaka are as follows:
- PM<sub>2.5</sub> (24-hr) = 170  $\mu\text{g}/\text{m}^3$   
PM<sub>10</sub> (24-hr) = 220  $\mu\text{g}/\text{m}^3$   
O<sub>3</sub> (8-hr) = 130  $\mu\text{g}/\text{m}^3$   
CO (8-hr) = 7 ppm
- Compute AQI for each parameter, and report AQI for that particular day (Given: T = 25 °C, P = 1 atm; Table for calculating AQI provided).

- (b). What are the major sources of indoor air pollution? 14  
 What do you understand by photochemical smog? Discuss the adverse impacts of photochemical smog.
- (c). Discuss the effects of air/fuel ratio on emissions of CO, hydrocarbon, and NO<sub>x</sub> 13  
 from four-stroke engines. Also explain the effects of air/fuel ratio on the efficiency of a 3-way catalytic converter.
- 4(a). Draw shapes of following types of plumes emitted from a smoke-stack, along with the corresponding temperature profile of the atmosphere: (i) Looping, (ii) Fumigating, (iii) Lofting. 17  
 Suppose the ambient temperature profile is given by the following equation:  
 $\Lambda = 29 - 0.004 Z$ , where  $Z$  = altitude in m
- (i) If maximum surface temperature is 36°C and average wind speed is 3.5 m/sec, compute the ventilation coefficient, and comment on the pollution potential of the area.
- (ii) If a plume is emitted at a temperature of 40°C at ground level, up to what height it would rise under the existing conditions?
- (b). What do you understand by "stable", "unstable" and "neutral" atmosphere? 8  
 Determine the nature of atmospheric stability for each of the following conditions of the ambient atmosphere: (i)  $dT/dz = 1.5 \text{ }^\circ\text{C/km}$ ; (ii)  $dT/dz = -2.0 \text{ }^\circ\text{C/km}$ ; (iii)  $dT/dz = 0$ .
- (c). Define "primary" and "secondary" pollutants with appropriate examples. What do you understand by "thermal NO<sub>x</sub>" and "fuel NO<sub>x</sub>"? Explain. What are the major adverse impacts of NO<sub>x</sub>? 14
- (d). List the principal assumptions of the "point source Gaussian plume model". 6

Table 7.2 Values of the constants  $a$ ,  $c$ ,  $d$ , and  $f$  for use in (7.44) and (7.45) expressions for  $\sigma_y$  and  $\sigma_z$

Stability	$a$	$x \leq 1 \text{ km}$			$x \geq 1 \text{ km}$		
		$c$	$d$	$f$	$c$	$d$	$f$
A	213	440.8	1.941	9.27	459.7	2.094	-9.6
B	156	106.6	1.149	3.3	108.2	1.098	2.0
C	104	61.0	0.911	0	61.0	0.911	0
D	68	33.2	0.725	-1.7	44.5	0.516	-13.0
E	50.5	22.8	0.678	-1.3	55.4	0.305	-34.0
F	34	14.35	0.740	-0.35	62.6	0.180	-48.6

Note: The computed values of  $\sigma$  will be in meters when  $x$  is given in kilometers.  
 Source: Martin (1976).

$$\sigma_y = a \cdot x^{0.894} \quad ; \quad \sigma_z = c x^d + f$$

Table 1: AQI for different pollutants (for ques. no. ~~16~~)

Breakpoints										AQI
O <sub>3</sub> (ppm) 8-hr	O <sub>3</sub> (ppm) 1-hr (i)	PM <sub>2.5</sub> (µg/m <sup>3</sup> ) 24-hr	PM <sub>10</sub> (µg/m <sup>3</sup> ) 24-hr	CO (ppm) 8-hr	SO <sub>2</sub> (ppm) 24-hr	NO <sub>2</sub> (ppm) Annual				
0.000-0.064	--	0.0-15.4	0-54	0.0-4.4	0.000-0.034	(ii)				0-50
0.065-0.084	--	15.5-40.4	55-154	4.5-9.4	0.035-0.144	(ii)				51-100
0.085-0.104	0.125-0.164	40.5-65.4	155-254	9.5-12.4	0.145-0.224	(ii)				101-150
0.105-0.124	0.165-0.204	65.5-150.4	255-354	12.5-15.4	0.225-0.304	(ii)				151-200
0.125-0.374	0.205-0.404	150.5-250.4	355-424	15.5-30.4	0.305-0.604	0.65-1.24				201-300
(iii)	0.405-0.504	250.5-350.4	425-504	30.5-40.4	0.605-0.804	1.25-1.64				301-400
(iii)	0.505-0.604	350.5-500.4	505-604	40.5-50.4	0.805-1.004	1.65-2.04				401-500

(i) In some cases, in addition to calculating the 8-hr ozone index, the 1-hr ozone index may be calculated, and the maximum of the two values reported  
(ii) NO<sub>2</sub> has no short-term air quality standard and can generate an AQI only above 200  
(iii) 8-hr O<sub>3</sub> values do not define higher AQI values (≥301). AQI values of 301 or higher are calculated with 1-hr O<sub>3</sub> concentrations

**University of Asia Pacific**  
**Department of Civil Engineering**  
**Mid Semester Examination Spring 2012**

Course Code: CE 433  
Time: 1 Hour

Course Title: Environmental Engineering II

Credit: 2.0  
Full Marks: 100

[Assume reasonable value for missing data (if any)]

1. Due to inadequate sanitary sewerage facilities, people living in an urban center discharges untreated domestic wastewater, through an outfall, into a river at the rate  $0.75 \text{ m}^3/\text{s}$ . The wastewater has a  $\text{BOD}_5$  of  $75 \text{ mg/l}$ , DO of  $0.0 \text{ mg/l}$  and a temperature  $25^\circ\text{C}$ . Upstream of the outfall, the river has a flow rate of  $3.5 \text{ m}^3/\text{s}$ ,  $\text{BOD}_5$  of  $3 \text{ mg/l}$ , DO of  $6.5 \text{ mg/l}$ , and a temperature of  $25^\circ\text{C}$ . Laboratory determined BOD rate constant of the mixture is  $0.22$  per day, and estimated reaeration constant ( $K_r$ ) at  $20^\circ\text{C}$  is  $0.40$  per day. Velocity of the mixture is  $0.20 \text{ m/s}$ , and the saturation value of DO (i.e.,  $\text{DO}_{\text{sat}}$ ) at  $25^\circ\text{C}$  is  $8.60 \text{ mg/l}$ .  
(a) Find the minimum value of dissolved oxygen (DO) and the distance downstream at which the DO is minimum.  
(b) Find DO at a distance of  $10 \text{ km}$  downstream of the outfall. 36
  
2. A Lake with a surface area of  $8.5 \times 10^7 \text{ m}^2$  is fed by a stream having an average flow rate of  $6.5 \text{ m}^3/\text{s}$  and average total phosphorus concentration of  $0.05 \text{ mg/l}$ . The Lake also receives phosphorus from two other sources: A wastewater treatment plant with a flow rate of  $0.25 \text{ m}^3/\text{s}$  and a phosphorous concentration of  $6.0 \text{ mg/l}$ ; and a domestic sewage outfall with a flow rate of  $0.15 \text{ m}^3/\text{s}$  and phosphorus concentration of  $3.5 \text{ mg/l}$ . The phosphorus settling rate in the Lake is  $11 \text{ m}$  per year.  
(a) Estimate average phosphorus concentration in the Lake.  
(b) If a treatment unit is installed at the wastewater treatment plant to remove  $90\%$  phosphorus from wastewater, what would be the phosphorus concentration in the Lake? 16
  
3. Answer **ANY TWO** of the following **THREE** questions 10 × 2
  - (a) What do you understand by "point sources" and "non-point sources" of pollution? What do you understand by "pathogens"? What are its sources? Which tests are carried out to detect the presence of pathogens in water?
  - (b) What are the main toxicological effects (i.e., health effects) of arsenic? Write down the different chemical forms in which inorganic Arsenic (As) could exist in water.
  - (c) The ultimate CBOD (i.e.,  $L_0$ ) and  $\text{BOD}_5$  (at standard condition) of a wastewater sample are  $290 \text{ mg/l}$  and  $175 \text{ mg/l}$ , respectively.  
Estimate the 4-day CBOD (i.e.,  $\text{BOD}_4$ ) of the wastewater at  $26^\circ\text{C}$ .
  
4. Answer **ANY TWO** of the following **FOUR** questions 14 × 2
  - (a) What do you understand by eutrophication? Which nutrients are primarily responsible for eutrophication? Briefly explain how eutrophication can be controlled.
  - (b) Explain how high concentration of Ammonia in the raw water (from Sitalakhya river) interferes with the pre-chlorination process at the Saidabad Water Treatment Plant (SWTP).
  - (c) Classify pesticides and insecticides (with examples). Why use of certain groups of insecticides are being discontinued world-wide.  
What do you understand by VOCs? Give examples.
  - (d) What are the possible alternatives to arsenic-contaminated groundwater in Bangladesh? Schematically (with simple sketches) show the mechanism of As removal from water by coagulation-adsorption-coprecipitation technique.

**The University of Asia Pacific**  
**Department of Civil Engineering**  
**Mid-Term Examination, Spring 2012**

Course # CE 441  
 Full Marks: 45 (15 x 3 = 45)

Course Title: Geotechnical Engineering II  
 Time: 1 hour

Answer any three (3) of the following four (4) questions

1. Give a brief overview of subsurface exploration from geotechnical engineering point of view. 15
2. (a) Write down any two general guidelines used for selection of number and depth of boreholes. 4  
 (b) The outside and inside diameters of a split spoon sampler are 2 inches and 1-3/8 inches, respectively. The degree of disturbance (DOD) of a Shelby tube sampler is one-twelfth the DOD of the split spoon sampler. If the inside diameter of the Shelby tube sampler are 73 mm, determine its outside diameter. 4  
 (c) Write short notes on (any two): 3.5 x 2=7  
     (i) Standard penetration test   (ii) Undisturbed sampling   (iii) Logging
3. A geotechnical site investigation was conducted at a site using a standard sampler. Borehole diameter was 150 mm. Consider  $E_m$  to be equal to 0.5. 15  
 - Determine the field SPT-N-values  
 - Apply necessary corrections and calculate corrected SPT-N-values as required  
 - Determine  $C$  and  $\phi$  of the soils, as applicable, at corresponding depths  
 - Use appendix as necessary

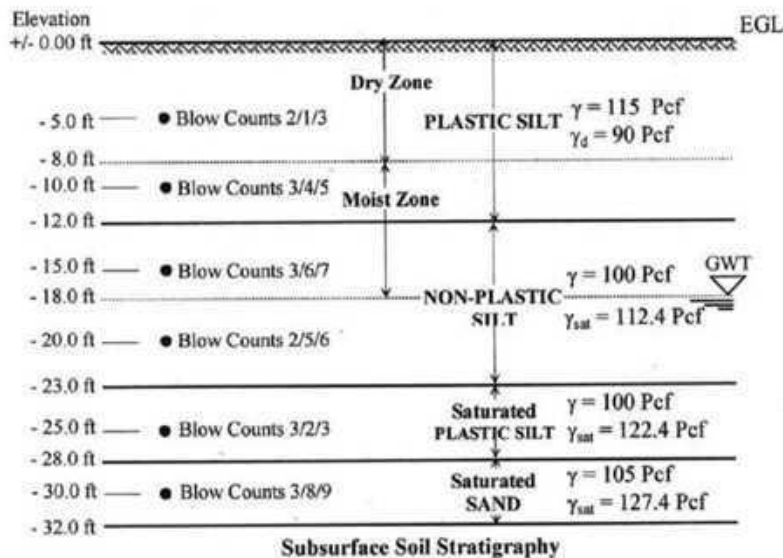

4. (a) Categorize foundation (shallow and deep). 5  
 (b) Sketch with very brief description the shear failure mechanisms of shallow foundation system for various types of soils. 10

**Appendix**

**Parameter for 60% Energy Correction For Field SPT-N Value**

$C_B$ = Correction for Borehole Diameter	= 1.0 (For Dia 2.5" – 4.5") = 1.05 (For Dia of 6") = 1.15 (For Dia 8")
$C_S$ = Correction for Sampler	= 1.0 Standard Sampler = 1.2 Sampler Without Liner
$C_R$ = Correction for Rod Length	= 0.75 for $L = (3-4)$ m = 0.85 for $L = (4-6)$ m = 0.95 for $L = (6-10)$ m = 1.0 for $L > 10$ m

**University of Asia Pacific**  
**Department of Civil Engineering**  
**Mid Examination Spring 2012**  
**Program: B.Sc Engineering (Civil)**

Course Title: Transportation Engineering –II:  
Highway Design & Railways  
Time : 3 Hours

Course Code: CE 451  
Full Marks: 75

---

There are **FOUR** questions in this section. Answer any **THREE**.

---

1. (a) What is dual gauge? Why is it desirable to use uniform gauges in a country? (3+7)  
(b) Why generally the followings are favored? (15)  
(i) Broken Stone (ii)Screw spike (iii) Elastic fastening
  
2. (a) What is the function of Geo-Textile? (5)  
(c) What is transition curve? What are the advantages of transition curve? (5)  
(b) Compute the steepest gradient that a train of 25 wagons with a locomotive with 5 pairs of driving wheels having an axle load of 22 tons each can travel with the following data: (15)  

Weight of each wagon	= 23 tones
Weight of locomotive	= 150 tones
Rolling resistance of locomotive	= 2 kg/tonne
Rolling resistance of wagon	= 3 kg/tonne
Speed of the train	= 70 kmph
Coefficient of friction.	= 0.1
  
3. (a) Briefly list the important requirements of ideal (15)  
(i) Rail  
(ii) Sleeper  
(iii) Ballast  
(b) What is the function of rubber pad? (4)  
(c) Find out the length of the transition curve for a M.G curve of three degrees, having a cant of 10 cm. The maximum permissible speed on the curve is 80 km p.h. (6)
  
4. (a) Work out the maximum speed of a train on a B.G. track having a curvature of three degrees and cant of 10 cm. Assume allowable cant deficiency as 76 mm. (12)  
(b) Why is it necessary to provide the followings (8)  
(i) Cant Deficiency (ii) Tilting of rail (iii) Coning of wheel  
(c) Establish a relationship between degree of curvature and radius. (5)

**University of Asia Pacific**  
**Department of Civil Engineering**  
**Mid Semester Examination Spring 2012**

Course No: CE 461

Course Title: Irrigation and Flood Control

Time: 1 hour

Total Marks: 60

---

**Section A**

---

**Answer all questions**

1. Define the following (any two) (2+2)
  - a. Efficiency of water-conveyance
  - b. Water distribution efficiency
  - c. Net Irrigation Requirement
2. Write two advantages and two disadvantages of irrigation. What is meant by 'Duty' and 'Delta'? Derive a relationship between duty and delta for a given base period. (2+2+4)
3. What are the various types of impurities present in irrigation water? (6)
4. Write five precautions in using saline water in irrigation. (5)
5. After how many days will you irrigate to ensure proper growth of the given crop, if, (7)
  - Field capacity of the soil = 30%
  - Permanent wilting point = 14%
  - Dry density of soil = 1.3 gm/cc
  - Effective depth of root zone = 70 cm
  - Daily consumptive use of water for the given crop = 12 mm.
6. Determine the time required to irrigate a strip of land of 0.04 hectares in area from a tube-well with a discharge of 0.02 cumec. The infiltration capacity of the soil may be taken as 5 cm/h and the average depth of flow on the field as 10 cm. Also determine the maximum area that can be irrigated from this tube well. (6)
7. Find the delta for a crop when its duty is 500 hectares/cumec on the field, the base period of this crop is 100 days. (4)

---

**Section B**

---

**Answer Question no.1 and any ONE from the rest**

1. (a) Define flood. What are the causes of flood? (3+3)  
(b) Write short note on types of floods in Bangladesh. (6)
2. Explain the following (any four) (2×4 = 8)
  - i) Critical Characteristics of flood
  - ii) Channel capacity
  - iii) Bankful stage
  - iv) Design flood
  - v) Catastrophic flood
3. Explain the impact of flood. (8)

**The University of Asia Pacific**  
**Department of Civil Engineering**  
**Mid Term Examination Spring 2012**  
**Program: B. Sc. Engineering (Civil)**

Course Title: Chemistry

Time: 1 Hours

Course Code: CHEM 111

Full Marks: 40

---

There are FIVE Questions. Answer any FOUR.

1. (a) What is atomic spectra ? (2)  
(b) Discuss the atomic spectra of hydrogen. (4)  
(c) Uranium has atomic number 92 and atomic weight 238.029. Find its number of electron, proton and neutron. (4)
  
2. (a) State Hund's rule. (2)  
(b) Write the electronic configurations of the O atom and the  $P^{-3}$  ion. (4)  
(c) Draw the shapes of s- and p-orbitals. (4)
  
3. (a) What is Orbital. (2)  
(b) What are the shapes of the orbitals when the Azimuthal quantum number,  $l = 0, 1, 2$  and 3. Find the value of  $m_l$  for each value of  $l$ . (4)  
(c) Draw the atomic structures of  ${}_{17}\text{Cl}^{37}$  and  ${}_{8}\text{O}^{18}$  isotopes. (4)
  
4. (a) What is meant by 'ionic bond' ? (2)  
(b) Show that the bonds in NaCl and  $\text{MgCl}_2$  are ionic in nature. (4)  
(c) What is co-ordination bond? Show that  $\text{H}_2\text{SO}_4$  has two co-ordination bonds. (4)
  
5. (a) What is 'bond order' ? (2)  
(b) Draw the molecular orbital of  $\text{H}_2^+$  and thus predict the bond order and magnetic property of  $\text{H}_2^+$ . (4)  
(c) What is 'sp<sup>3</sup> hybrid bond' ? Explain sp<sup>3</sup> hybridization in  $\text{CH}_4$  molecule. (4)

**The University of Asia Pacific**  
**Department of Civil Engineering**  
**Mid Term Examination Spring-2012**  
**Program: B. Sc Engineering (2nd Year/ 1<sup>st</sup> Semester)**

Course Title: Basic Electrical Engineering  
 Time: 1.00 Hour

Course No. ECE 201

Credit Hours: 3.00  
 Full Marks: 60

[There are **four** questions. Answer any **three**. Figures in the right margin indicate marks]

1. a. State the following laws: [8]
- (i) Ohm's Law
  - (ii) Kirchhoff's Voltage Law (KVL)
  - (iii) Kirchhoff's Current Law (KCL)

- b. Find  $V_x$  and  $i_x$  using KVL or KCL. [12]

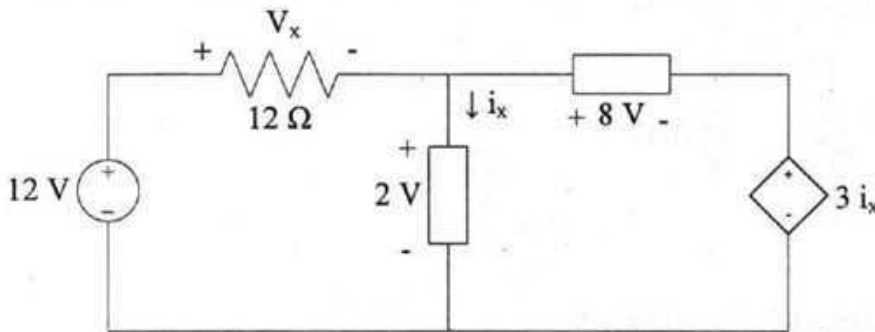

2. a. What do you understand by short and open circuit conditions? [6]
- b. Using series/parallel combination find the equivalent resistance as indicated in the figure [14]

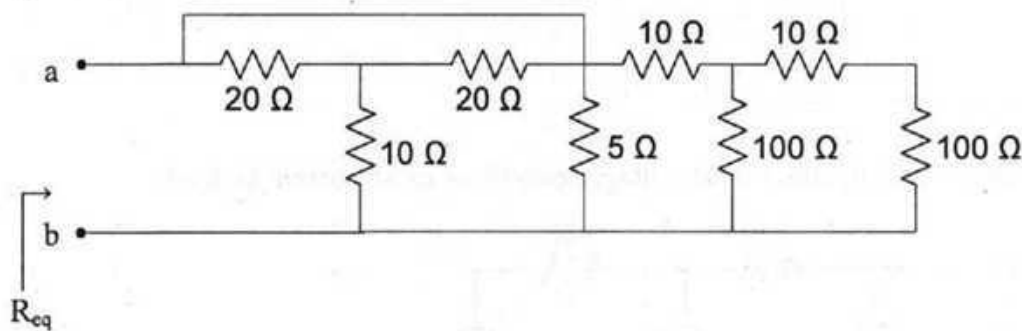

3. Calculate  $i_1$  using superposition theorem.

[10]

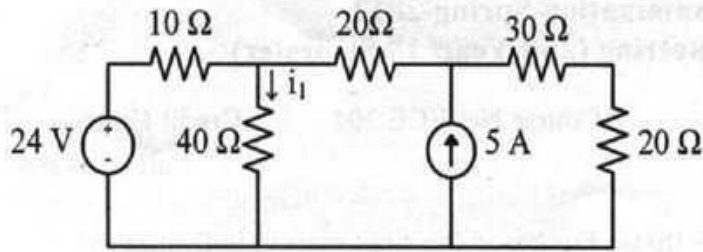

b. Using voltage divider rule calculate  $V_o$  in the circuit. Also calculate the current ' $i$ ' shown in the figure.

[10]

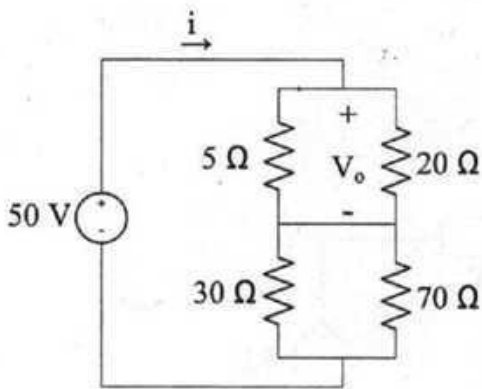

4. a. Using node voltage analysis calculate  $V_o$ .

[10]

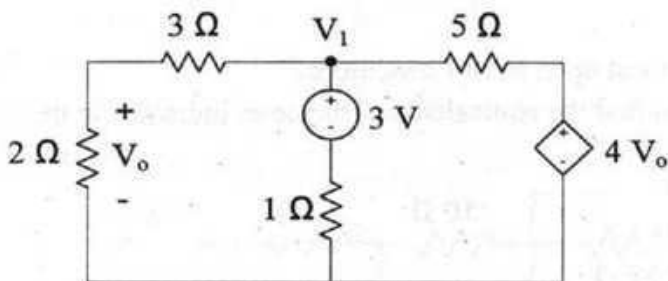

b. Calculate  $V_o$  using either node voltage analysis or mesh current analysis.

[10]

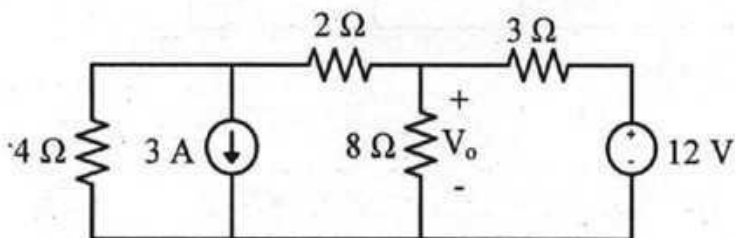

**University of Asia Pacific**  
**Department of Basic Sciences and Humanities**  
**Mid-Term Examination, Spring-2012**  
**Programmes: B.Sc Engineering (Civil and Computer Science)**

Course Title: Principles Of Economics  
Time: 1.00 Hour

Course Code: ECN 201

Credit: 2  
Full Marks: 40

---

Answer any **FOUR** of the following Questions (No. 1-5)

**Marks: 10 × 4 = 40**

1. a) What is Economics? Distinguish between Microeconomics and Macroeconomics. (4)  
b) How does the production possibility curve illustrate the opportunity cost? (6)
2. a) Explain the law of demand and law of supply. (2)  
b) Given

$$Q_d = 8000 - P_x$$

$$Q_s = -4000 + 2000P_x$$

Find the Equilibrium price and Quantity and illustrate it graphically. (8)

3. a) What does the price elasticity of demand refer? (2)  
b) What are the major determinants of price elasticity of demand? Explain. (8)
4. a) What is budget line? (2)  
b) Explain the Engel curve with the help of income consumption curve.  
Present all necessary diagrams. (8)
5. Show that price effect is equal to substitution effect and income effect.  
Present all necessary diagrams. (10)

# University of Asia Pacific

Mid Term Examination

Spring 2012

Course no.: HSS 101

Course Title: English Language I

Time: 1.00 Hour

Full Marks: 20

Name: _____
Registration No.: _____ Date: _____
Department: _____
Invigilator's Signature: _____

**(Answer all the questions on the question paper)**

**Q 1. The following extract is about Abid, a lawyer of 28. After reading the passage, complete the questions.** **5 × 1 = 5**

Abid is 28 years old and lives in Dhaka, Bangladesh. He works hard as a lawyer from Sunday to Thursday. But he plays cricket for the Central Dhaka Cricket Team at the weekends. On Fridays he practices in the field and on Saturdays he is in a match. He has no free time. But he likes his job and playing cricket.

- How \_\_\_\_\_ Abid?
- What \_\_\_\_\_ ?
- \_\_\_\_\_ weekends?
- Where \_\_\_\_\_ on Saturdays?
- Does \_\_\_\_\_ ?

**Q 2. Complete any three of the following sentences with negatives.**

**3 × 1 = 3**

- Fear and courage \_\_\_\_\_ function at the same time.
- An honest person \_\_\_\_\_ anybody.
- Sharmin \_\_\_\_\_ the task because she had found it uninteresting.
- Shahed has got a toothache. The doctor advised him \_\_\_\_\_ extremely cold water.
- A slum \_\_\_\_\_ for little children.

Q 3. Complete any five the following sentences using appropriate forms of pronouns.  $5 \times 0.5 = 2.5$

- a. It was \_\_\_\_\_ duty to be punctual at the first place.
- b. Monica won the first prize for \_\_\_\_\_ extraordinary academic accomplishment.
- c. Please do not blame yourself. I have made the blunder and the fault is completely \_\_\_\_\_.
- d. Hi Tariq! Is that new bike \_\_\_\_\_?
- e. The workers have done \_\_\_\_\_ job very quickly.
- f. The library is famous for \_\_\_\_\_ vast collection of books.
- g. A tree looks beautiful when green leaves grow in \_\_\_\_\_ branches.

Q 4. Read the following passage and put in the missing *a, an, the* or *-* (for no article) where necessary.  $10 \times 0.25 = 2.5$

Most of \_\_\_\_\_ people think of dinosaurs as big, ferocious and extinct reptiles. That is largely true, but there are some misconceptions. The word dinosaur, which means "terrible lizard," was coined in 1842, but now we know that dinosaurs aren't lizards, although they \_\_\_\_\_ share a common ancestor. Lizards as \_\_\_\_\_ group are primitive compared to dinosaurs. Dinosaurs were \_\_\_\_\_ largest land animals of all time, but \_\_\_\_\_ great number of dinosaurs were smaller than \_\_\_\_\_ turkey. Dinosaurs as a group got bigger over time until \_\_\_\_\_ extinction event 65 million years ago wiped out all but bird-like dinosaurs. Scientists don't agree entirely on what happened, but the extinction likely was \_\_\_\_\_ double or triple whammy involving \_\_\_\_\_ asteroid impact, choking chemicals from erupting volcanoes, climate \_\_\_\_\_ change and possibly other factors.

Q 5. Write a biography of Steven Paul Jobs, famous for his affiliation with techno-giant Apple, from the information provided below. 7

Steven Paul Jobs, famously known as Steve Jobs was an entrepreneur, computer programmer and an inventor.

Short Profile:

24 February, 1955: Born.

1972: Graduated from Homestead High School in Cupertino, California.

1972: Entered Reed College in Portland but dropped out after one semester.

1974: Took a position as a video game designer with Atari.

1976: Started Apple Computers with Stephen Wozniak.

1980: Apple Computer became a publicly traded company with a market value of \$ 1.2 billion on the very first day of trading.

1985: Resigned as Apple's CEO to begin a new Hardware and Software Company named NeXT, Inc.

1986: Purchased an animation company from George Lucas, which later became Pixar Animation Studio.

18 March, 1991: Got married to Laurene Powell.

1997: Returned to his post as Apple's CEO.

2003: He discovered that he had a rare but operable pancreatic cancer.

5 October, 2011: He died at the age of 56.

Approved  
S M Ahmadullah  
Professor

Moderated  
Ahmadullo

**University of Asia Pacific**  
**Department of Architecture/ Business Admin/ CE/ CSE**

Mid-term Examination: Spring 2012

Program: B Arch/ BBA/ B. Sc Engineering

Course Title: English Language II

Course Code: HSS 103

Credit: 3.00

Time: 1.00 Hour

Full Marks: 20

Name of the Student:..... Registration No:.....

Invigilator's Signature:..... Examiner's Signature:..... Marks obtained:.....

1. Rewrite **any six (06)** of the following sentences correctly: 03

a) Statistics are an interesting subject.

Ans: .....

b) My friends and my mother knows each other.

Ans: .....

c) Neither the apples nor the basket cost high.

Ans: .....

d) Living in big cities almost always cause stress because of traffic jam.

Ans: .....

d) Rafiq is selected as the captain of his class.

Ans: .....

f) Its a serious matter, we should not ignore.

Ans: .....

g) A high percentage of the population is voting for the new school.

Ans: .....

h) Our teacher helps us to understand the lesson properly.

Ans: .....

2. Change the forms of voice of **any six (06)** of the following sentences: 03

a) They helped us doing the work.

Ans: .....

b) Karim was offered a job.

Ans:.....

c) They will deliver the products by next week.

Ans: .....

d) Have they cleaned the swimming pool yet?

Ans: .....

e) How do people learn languages?

Ans: .....

f) Who is asking for me?

Ans: .....

g) Wow! He has won the match.

Ans: .....

h) None has completed the work.

Ans: .....

3. Complete any **four (04)** of the following sentences using correct conditional structures: 02

a) If I knew his number,.....

b) .....if the weather is good.

c) If I did not work late,.....

d) ....., I will ask from you.

e) If your work had been finished,.....

f) ..... if I were present there.

4. Change the forms of speeches of any **six (06)** of the following sentences: 03

a) The teacher said to me, "Why did you not join the game?"

Ans: .....

b) My friend said to me, "Never lose your heart."

Ans: .....

c) Rahim told that he was very happy to know his result.

Ans: .....

d) She said, "I can speak Italian."

Ans: .....

e) He said to me, "I have already expressed my opinion"

Ans: .....

f) Ruksana said to me, "I don't have much free time."

Ans: .....

g) The children said, "What a nice cake it is!"

Ans: .....

h) "Fill in the form, Sir," the Receptionist said.

Ans: .....

5. Make sentences with any **two (02)** of the following pairs of words: 02

a) Reply:.....

Answer:.....

b) Between:.....

Among:.....

c) Discover:.....

Invent:.....

6. Write one synonym and one antonym of any *two (02)* of the following words and make sentences with those synonyms and antonyms: 04

a) Familiar:

Synonym:..... Sentence: .....

Antonym:..... Sentence: .....

b) Durable:

Synonym:..... Sentence: .....

Antonym:..... Sentence: .....

c) Enhance:

Synonym:..... Sentence: .....

Antonym:..... Sentence: .....

7. Make sentences with any *six (06)* of the following phrases: 03

a) Storm in the teacup: .....

b) Out of the blue:.....

c) Hand in Hand:.....

d) Break the ice:.....

e) Keep an eye on: .....

f) A white lie:.....

g) Play with fire:.....

h) Easier said than done: .....

**University of Asia Pacific**  
**Department of Basic Sciences and Humanities**  
**Mid Semester Examination, Spring 2012**  
**Programmes: BArch, BBA, BSc Engineering (CE, CSE, EEE)**

**Course Title: Bangladesh Studies: Society and Culture**      **Course Code: HSS 111(a)**  
**Credit: 2.00**      **HSS 211(a) [for CE]**

**Time: 1 Hour**      **Full Marks: 40**

*There are two sections in the question paper namely "SECTION A" and "SECTION B". You have to answer from both sections according to the instruction mentioned in each section.*

**SECTION A**

There are **FOUR** questions in this section. Answer **ANY THREE** (3x10)

1. Discuss the scope and subject matter of sociology.
2. Discuss in brief on the key concepts of five early sociologists.
3. Discuss on social survey or the method of participant observation.
4. Discuss with examples the different types of marriage and family. Which type of family is mostly seen in Bangladesh?

**SECTION B**

There are **THREE** questions in this section. Answer **ANY TWO** (2x5)

5. Discuss on two branches of sociology.
6. Name the steps followed in scientific method.
7. What are the functional pre-requisites of a society according to Morris Ginsberg?

f. Salaries of 800 are accrued and unpaid at May 31.

**Requirement: Make adjusting entry of the following transactions.**

4. Kara Shin is a licensed CPA. During the first month of operations of her business, the following events and transactions occurred **(10\*.5=5)**

**May 1** Shin invested 20000 cash.

2 Purchases 1500 of supplies on account from Read Supply Company.

3 Hired a secretary receptionist at a salary of 1000 per month.

4 Paid office rent of 900 cash for the month.

7 Completed a tax assignment and billed client 2100 for service provided.

12 Received 3500 advance on a management consulting engagement.

17 Received cash of 1200 for service completed for H. Arnold.

31 Paid secretary receptionist 1000 salary for the month.

31 Paid 40% of balance due Read Supply Company.

31 One half of the service has been provided (Related to May 12)

5. **Make a Trial Balance from the following transaction :**

4

Cash 6485, Accounts Receivable 885, Prepaid Rental 900, Land 10000, Building 8000, Equipment 6000, Accounts Payable 2000, Mortgage Payable 6000, Capital 20000, Admission Revenue 7000, Concession Revenue 170, Advertising Expense 300, Rental expense 1000, Salaries expense 1600.

UNIVERSITY OF ASIA PACIFIC

Department of Basic Sciences and Humanities

Mid Term Examination Fall 2012

Programme: BBA, BSc Engineering (Civil, Computer Science, Electrical and Electronic)

Course Title: Bangladesh Studies: History of Bangladesh

Course Code: HSS 111(b); HSS 211(b) (for CE)

Credit: 2.00

Time: 1 Hour

Full Marks: 40

There are FIVE questions in this section. Answer ANY FOUR (4 x 10 = 40)

1. Discuss the different opinions regarding the origin of the name of Bangladesh.
2. What were the *janapadas*? Identify the present location of the different *janapadas* of ancient Bengal.
3. Briefly describe the main achievements of Shashanka.
4. What do you mean by the term *matsyanyam*? Discuss when & how was it ended.
5. Write about the major impacts brought in Bengal with the arrival of Islam.

**The University of Asia Pacific**  
**Department of Civil Engineering**  
**Mid-Term Examination, Spring-2012**  
**Program: B.Sc Engineering (Civil)**

Course Title: Principles of Management  
Time: 1 hour

Course Code: IMG 301  
Full Marks: 40

---

**Answer any 3 (three) of the following questions. All questions are of equal value.**

1. Define and explain "Management"? "All managers carry out managerial functions, but the time spent for each function may differ"- explain. Why you need to study management as a student of civil engineering department?
2. What are the management functions? How do the required managerial skills differ in the organizational hierarchy? What are the differences between productivity, effectiveness and efficiency?
3. Why has Frederick Taylor been called "the father of scientific management" and Henri Fayol "the father of modern management theory"? Discuss the Managerial Roles Approach for management analysis.
4. State the internal and external environment in which managers operate. What are the major social responsibilities of business managers? Discuss.
5. How would you define "planning"? Briefly state the nature of planning. Discuss the steps in planning.

UNIVERSITY OF ASIA PACIFIC  
 Department of Basic Sciences and Humanities  
 Mid-Semester Examination Spring 2012  
 Program: B.Sc. Engineering (Civil)

Course Title: Mathematics I  
 Time: 1.00 Hr.

Course Code: MTH 101  
 Full Marks: 60

*N.B.: Answer any 4 (FOUR) questions. Figures in the right margin indicate the marks of the respective questions.*

- Q1. (a) Define domain and range of a function  $f(x)$ . 3  
 (b) Sketch and determine the domain and range of the following functions : 12  
 (i)  $f(x) = 3x + |3 - x|$     (ii)  $f(x) = |\cos x| + 2$     (iii)  $f(x) = |x| - |x - 2|$
- Q2. (a) Define continuity of a function  $f(x)$  at a point  $x = x_0$ . Find the value of  $k$  for which the function 8  

$$f(x) = \begin{cases} \frac{x^2 - 4}{x - 2}, & x \neq 2 \\ k, & x = 2 \end{cases}$$
 will be continuous at  $x = 2$ . 7  
 (b) Define  $\delta - \varepsilon$  definition of continuity of  $f(x)$  at  $x = a$ . Prove that  $\lim_{x \rightarrow 3} 4x - 5 = 7$
- Q3. (a) Define continuity from the left and continuity from the right. Test the continuity of  $f(x) = \sqrt{16 - x^2}$  on  $[-4, 4]$ . 10  
 (b) Test the continuity of  $f(x) = x^2 + 2x + 1$  at  $x = 0$ . 5
- Q4. (a) Test the differentiability of  $f(x)$  at  $x = 1$ , where,  $f(x) = |x + 1| + |x - 1|$ . 10  
 (b) Oil spilled from a ruptured tanker spreads in a circle whose radius increases at a rate of 0.75 m/sec. How fast will the area of the circle increase when the radius is 1.25 meter? 5
- Q5. (a) State and prove Leibnitz's theorem. 8  
 (b) If  $y = e^{m \cos^{-1} x}$  then show that  $(1 - x^2)y_{n+2} - (2n + 1)xy_{n+1} - (n^2 + m^2)y_n = 0$  7

**UNIVERSITY OF ASIA PACIFIC**  
**Department of Basic Sciences and Humanities**  
**Mid-Semester Examination Spring 2012**  
**Program: B.Sc. Engineering (Civil)**

Course Title: Mathematics II  
Time: 1.00 Hr.

Course Code: MTH 103  
Full Marks: 60

**N.B.** Answer any four (4) questions from the following.

1. (a) Find the intercept form of an equation of a plane. 7  
(b) Show that the four points are coplanar  $(0, 4, 3)$ ,  $(-1, -5, -3)$ ,  $(-2, -2, 1)$   
and  $(1, 1, -1)$  8
2. (a) Find the equation of the plane which is perpendicular to the plane  $5x+3y+6z+8=0$   
and which contains the line of intersection of the planes  $x+2y+3z-4=0$   
and  $2x+y-z+5=0$ . 10  
(b) Find the direction cosines of the normal and length of the normal for the following  
plane  $x+2y+2z-1=0$ . 5
3. (a) Find the equation of the plane that passes through  $(2, -3, 1)$  and is normal to the  
line joining the points  $(3, 4, -1)$  and  $(2, -1, 5)$ . 8  
(b) Find the co-ordinates of the intersection of the line  $\frac{x+1}{1} = \frac{y+3}{5} = \frac{z-3}{3}$  with the  
plane  $3x+4y+5z=5$ . 7
4. (a) Find the shortest distance between two given lines whose direction cosines  
are  $l_1, m_1, n_1$  and  $l_2, m_2, n_2$ . 10  
(b) Find the equation of the line through the point  $(1, 2, 3)$  and perpendicular to the  
line  $x-2y+3z-5=0=3x+y+2z-6$ . 5
5. (a) Find the equation of the plane through the points  $(2, -1, 0)$ ,  $(3, -4, 5)$  and parallel to  
the line  $2x=3y=4z$ . 7  
(b) Find the shortest distance between the lines  $\frac{x-1}{2} = \frac{y-2}{3} = \frac{z-3}{4}$  and  
 $\frac{x-2}{3} = \frac{y-3}{4} = \frac{z-4}{5}$ . 8

**UNIVERSITY OF ASIA PACIFIC**  
**Department of Basic Sciences & Humanities**  
**Mid Semester Examination Spring 2012**  
**Program: B. Sc. Civil Engineering (CE)**  
**Course Title: Mathematics III**

Course Code: MTH 201  
Full Marks: 60

Credit: 3.00  
Time: 1(one) hour

Answer any four of the followings:

4×15 = 60

1. (a) Define inverse of a matrix. Does the inverse of a square matrix always exist? (5)  
Make your comments.

- (b) Solve for the following system of linear equations by using Cramer's rule. (10)

$$2x_1 - 2x_2 + x_3 = 3$$

$$3x_1 + x_2 - x_3 = 7$$

$$x_1 - 3x_2 + 2x_3 = 0$$

2. (a) Solve the following system by using Gauss- Jordan Elimination. (10)

$$5x - 3y + 2z = 13$$

$$2x - y - 3z = 1$$

$$4x - 2y + 4z = 12$$

- (b) Given that  $A = \begin{pmatrix} 1 & 2 & -3 \\ 5 & 0 & 2 \\ 1 & -1 & 1 \end{pmatrix}$  and  $B = \begin{pmatrix} 1 & 3 \\ 2 & -1 \\ 0 & 4 \end{pmatrix}$ , find  $AB^t$  and  $BA^t$  if possible. (5)

3. (a) Define linear combination of vectors. Determine whether or not the vector  $(9, 2, 7)$  is a linear combination of the vectors  $(1, 2, -1)$  and  $(6, 4, 2)$  in  $\mathbb{R}^3$ . (7)

- (b) Write the matrix  $E = \begin{pmatrix} 2 & 1 \\ -1 & -2 \end{pmatrix}$  as a linear combination of the matrices (8)

$$A = \begin{pmatrix} 1 & 1 \\ 0 & -1 \end{pmatrix}, B = \begin{pmatrix} 1 & 1 \\ -1 & 0 \end{pmatrix} \text{ and } C = \begin{pmatrix} 1 & -1 \\ 0 & 0 \end{pmatrix}.$$

4. Determine the value of  $k$  such that the following system of equations  $x, y$  and  $z$  has: (15)

- |       |                        |                    |
|-------|------------------------|--------------------|
| (i)   | a unique solution,     | $x - 3z = -3$      |
| (ii)  | no solution            | $2x + ky - z = -2$ |
| (iii) | more than one solution | $x + 2y + kz = 1$  |

5. (a) Define linear dependence and independence of vectors. (3)

- (b) Determine whether the vectors  $v_1 = (1, -2, 1)$ ,  $v_2 = (2, 1, -1)$  and  $v_3 = (7, -4, 1)$  in  $\mathbb{R}^3$  are linearly dependent or independent. (12)

**UNIVERSITY OF ASIA PACIFIC**  
**Department of Basic Sciences and Humanities**  
**Mid-Semester Examination Spring 2012**  
**Program: B.Sc. Engineering (Civil)**

Course Title: Mathematics IV  
Time: 1.00 Hr.

Course Code: MTH 203  
Full Marks: 60

**Answer any four of the followings:**

4 × 15 = 60

1. Define Fourier series. Determine the coefficients of  $a_0$ ,  $a_n$  and  $b_n$  of Fourier series.
2. Explain even and odd function. Derive the form of Fourier integral of an even function.
3. Define ordinary differential equation. Form an ordinary differential equation from the following equation

$$y = c_1 e^{2x} \cos 3x + c_2 e^{2x} \sin 3x.$$

4. Write down the standard form of Linear equation. Consider the following ordinary differential equation

$$(x^2 + x - 2) \frac{dy}{dx} + 3(x+1)y = x - 1 \text{ and hence solve it.}$$

5. (a) Determine whether or not the given equation is exact

$$(ye^x + 2e^x + y^2)dx + (e^x + 2xy)dy = 0. \text{ If it is exact then solve it.}$$

- (b) Solve the differential equation  $(x - 4)y^4 dx - x^3(y^2 - 3)dy = 0.$

**University of Asia Pacific**  
**Department of Basic Sciences and Humanities**  
**Mid Semester Examination, Spring-2012**  
**Program: B.Sc Engineering (Civil)**

Course Title: Physics I  
 Time: 1.00 Hour

Course Code: PHY-101

Credit: 3.00  
 Full Mark: 60

[N.B- The figures in the right margin indicate full marks. There are **FIVE** questions. Answer any **FOUR**]

1. (a) State and explain the first law of thermodynamics. 10
- (b) When a system is taken from the state *A* to state *B* along the path *ACB*, 80 joules of heat flows into the system and the system does 30 joules of work (fig. below). 5
- (i) How much heat flows into the system along the path *ADB*, if the work done is 10 joules?
- (ii) The system is returned from the state *B* to the state *A* along the curved path. The work done on the system is 20 joules. Does the system absorb or liberate heat and how much?
- (iii) If  $U_A = 0$ ,  $U_B = 40$  joules, find the heat absorbed in the process *AD* and *DB*.

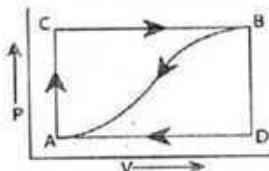

2. (a) Show that Work done during an isothermal process is  $W = RT \times 2.3026 \times \log_{10} \frac{P_1}{P_2}$  10
- (b) A motor car tyre has a pressure of 2 atmospheres at room temperature of  $27^\circ\text{C}$ . If the tyre suddenly bursts, find the resulting temperature. 5
3. (a) What is mean free path? Prove that mean free path of a molecule is  $\lambda = \frac{1}{\pi d^2 n}$  10
- (b) At what Celsius temperature will oxygen molecules have the same root mean square velocity as that of hydrogen molecules at  $-100^\circ\text{C}$ ? 5
4. (a) Show that the slope of an adiabatic curve is  $\gamma$  times steeper than that of the isothermal curve at a point where the curves intersect each other. 10
- (b) A quantity of air at  $27^\circ\text{C}$  and normal atmospheric pressure is suddenly compressed to half its original volume. Find the final pressure and temperature. 5
5. Derive the differential equation of wave motion  $\frac{d^2 y}{dt^2} = v^2 \frac{d^2 y}{dx^2}$ , where the symbols have their usual meanings. 15