

University of Asia Pacific
Department of Civil Engineering
MidTerm Examination
Spring 2014
Program: B.Sc. Engineering (Civil)

Course Title: Engineering Mechanics I
Time: 1 hour

Course Code: CE 101
Full Marks: 20

Answer all the questions.

(4x5=20 marks)

1. Calculate the magnitude of the force 'F' and the direction (θ) of the resultant of the given force system. 'R' is the resultant force of the force system consisting of 5 forces. Given that the angle θ is less than 90° .

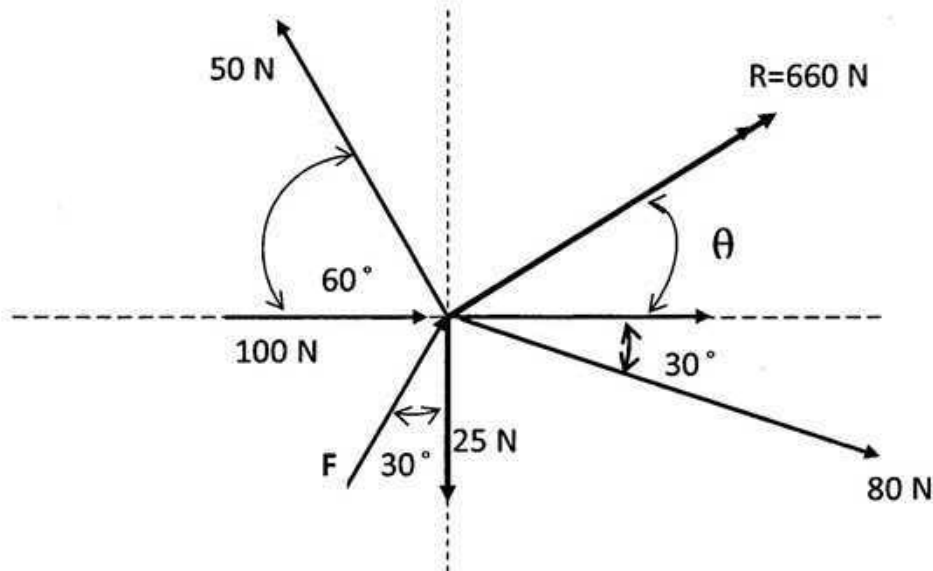

Figure 1

2. Two bodies (A and B) are connected by a cord and resting on smooth planes. Calculate the following: (a) the normal reaction between the body A and the plane, (b) the normal reaction between the body B and the plane, (c) tension in the cable, and (d) the slope (θ) of the plane in contact to body A. The system is in equilibrium. Given that, $W_A = 50$ lb and $W_B = 30$ lb.

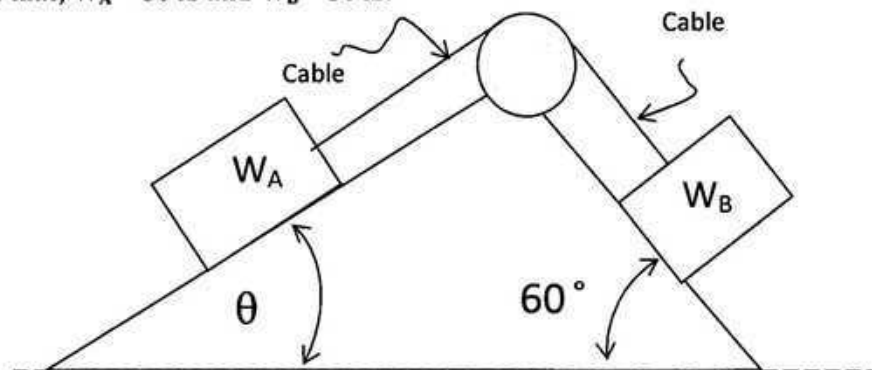

Figure 2

3. Determine the reactions at the supports of the beam as shown in Figure 3.

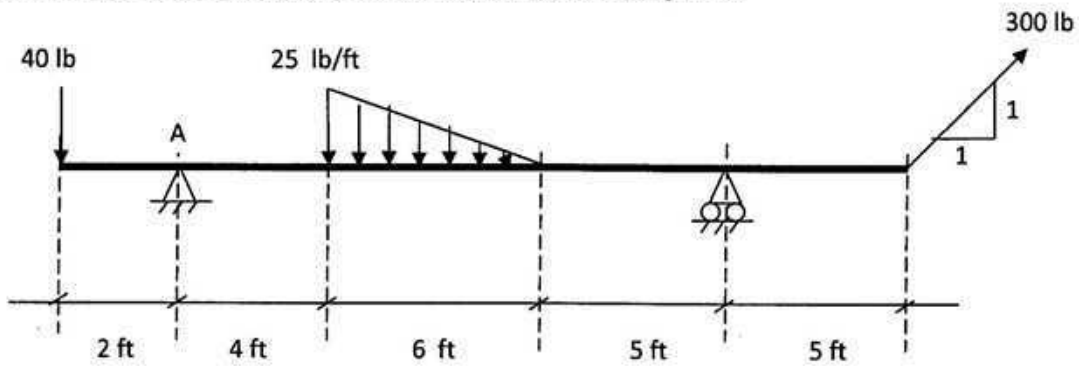

Figure 3

4. Determine the reactions at support A of the beam as shown in Figure 4. Also calculate (a) the values of shear force and bending moment at section B-B; (b) the values of shear force and bending moment at section C-C.

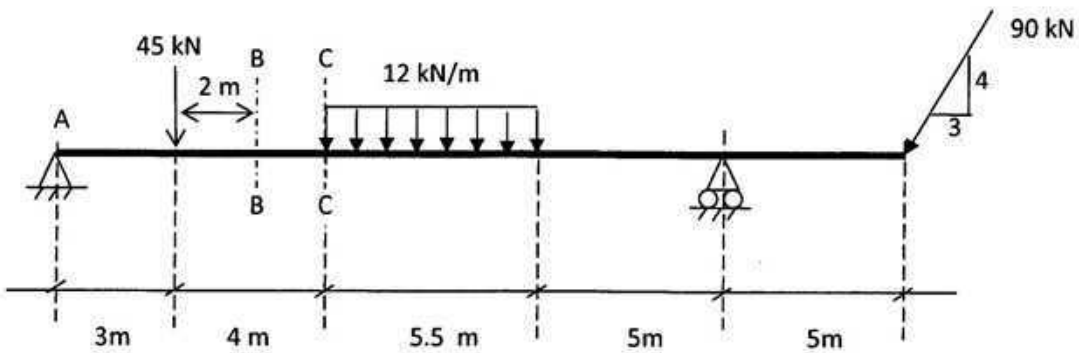

Figure 4

University of Asia Pacific
Department of Civil Engineering
Mid Semester Examination, Spring 2014

Course Code: CE 107

Course Title: Introduction to Civil & Environmental Engineering

Full Marks: 60

Time: 1 hour

There are Three (3) questions. Answer all the questions (20×3=60)

1. (a) Define "Structure". Name the factors that civil engineers are required to consider while designing a structure. [1+3=4]

(b) What do you mean by Structural Failure? What are the causes of Structural Failure? Name different modes of Structural Failure of steel. [1+4+3=8]

(c) What are the five major disciplines of Civil Engineering? Discuss the scope of work and major specialties for each discipline. [8]

2. (a) What are the major natural disasters in Bangladesh? Write down the names of four different river basins of Bangladesh. [3+2=5]

(b) What is Renewable Energy? What are the different modes of Renewable Energy? Which types of renewable energy are used in Bangladesh? [1+3+1=5]

(c) According to Dhaka Imarat Nirman Bidhimala, what are the steps associated with the approval of the design of a building? [4]

(d) Differentiate between (i) Sub-structure and Super-structure (ii) Normal Stress and Shear Stress (iii) Brittle Material and Ductile Material [6]

3. (a) What is Occupancy of a Building? According to BNBC, classify buildings based on occupancy. Write the names of each occupancy class. [1+5=6]

(b) A steel bar has a circular cross-section with diameter $d = 0.625$ in and an axial tensile load $P = 10$ kN is applied on it. Calculate the normal stress (σ). [4]

(c) The owner of a land is planning to construct a 6-story building on his land. The area of the land is 5 katha and the building will occupy 80% of the total land area. What is the value of Floor Area Ratio (FAR)? [4]

(d) Briefly explain the role of civil engineers in the infrastructure development. [6]

University of Asia Pacific

Department of Civil Engineering

Mid Semester Examination Spring 2014

Programme : B.Sc Engineering

Year: 1st, Semester: 1st

Course Code: HSS 101

Course Title: English I, Oral and Written Skills

Time: 1 Hour

Full Marks: 20

*Marks are indicated in the right margin

Answer all the questions on a separate answer script

1. Read the passage and complete the questions that follows:

5x 0.5=2.5

Career in mechanical engineering involves grappling with various aspects of the technical and practical work. The job of a mechanical engineer involves widespread handling of machines and components which have a direct relation with power by producing it, transmitting it or even making use of power. The major concern of mechanical engineers is bent towards ways and mechanisms through which natural energy sources are converted into uses of practical nature. As part of their work, mechanical engineers seek to come up with tools that are vital for other engineers to make use of them as they go about their daily routine. In order to work effectively, mechanical engineers need to work in a team of scientists and experts in various sectors of the engineering occupation who come up with theories and various other developments and innovations. In a more daily routine, mechanical engineers need to be complemented by other mechanical technicians in order that their work can be more effective.

- What _____ involve?
- What _____ concerned with?
- How _____ work effectively?
- Why _____ tools?
- Who _____ with the mechanical engineers?

2. Complete any five of the following sentences with negatives:

5x 0.5=2.5

- A liar _____.
- Learning time management is very important. You _____.
- We _____ assignment yet.
- She is a doctor but _____ surgical operations.
- Mr. Shamim _____ buy the car because it is too expensive.
- He _____ because he is slow.

3. Complete any five of the following sentences using the appropriate forms of pronouns:5x0.5=2.5

- All the books belong to him. It is _____.
- This is the key _____ he has lost.
- This assignment is _____. I prepared it last night.
- I know the man _____ anchored the programme.
- She needs _____ help to understand the situation.
- Mr. Azad has hired a car to take _____ family to the trip.

4. Complete the following sentences using articles where necessary:

5x0.5=2.5

Pluto is (a)_____ extremely distant world, orbiting (b)_____ sun more than 29 times farther than Earth. With (c)_____ surface temperature estimated to be about 380 degrees below zero Fahrenheit (around minus 229 degrees Celsius), (d)_____ environment at (e)_____ Pluto is far too cold to allow liquid water on its surface. Pluto's moons are in the same frigid environment. Pluto's remoteness and small size make it difficult to observe, but in July of 2015, NASA's New Horizons spacecraft will be the first to visit Pluto and Charon, and will provide the most detailed observations to date.

5. Complete the following sentences using appropriate prepositions:

6x0.5=3

- a. _____ my wall, there are many picture postcards.
- b. He did not keep the keys _____ the wardrobe.
- c. I was _____ the cinema last night.
- d. Mr. Khan was born _____ 25th March 1993.
- e. Would you like to go _____ the market?
- f. Who is the person _____ this picture.

6. Write a Biography of William Shakespeare, an English poet, playwright and actor, widely regarded as the greatest writer in the English language and the world's pre-eminent dramatist, from the information provided below. (Use past tenses appropriately)

7

1564: Born on 23rd April, in Stratford to John and Mary Arden Shakespeare.

1569: He goes to school, King's New School

1582: At the age of only 18, marries an older woman named Anne Hathaway.

1583: Birth of their first daughter Susanna.

1585: Anne Hathaway gives birth to twins, son Hamlet and daughter Judith. The babies are named after Shakespeare's close friends, Hamlet and Judith Sadler.

1590s: He writes the majority of his sonnets. He writes *Henry VI, Part One*—his very first play. Like all of Shakespeare's plays, the precise year of its authorship is now unclear. Also around the same time, Shakespeare leaves Stratford to begin work as a playwright and actor in London. Some of his famous dramas are *Romeo and Juliet*, *A Midsummer Night's Dream*, *The Merchant of Venice*, *Love's Labors Lost*, *Richard II* and *Titus Andronicus*.

1605: He buys some real estate near Stratford which soon doubles in value.

1616: Suffering from an unknown illness, William Shakespeare dies on his 52nd birthday.

University of Asia Pacific
Department of Basic Sciences & Humanities
Mid Semester Examination, Spring-2014
Program: B.Sc. Engineering (Civil, 1st year/ 1st semester)

Course Title: Mathematics I
 Time: 1 hr

Course Code: MTH 101

Credit: 3.00
 Full Marks: 60

Answer any **THREE** of the followings questions:

3×20 = 60

- Q1. (a) Define inverse function and constant function with examples. 6
 (b) Define domain and range of a function $f(x)$. Sketch and determine the domain and range of the following functions (any two): 14
 (i) $f(x) = x^2 - 3x + 2$ (ii) $f(x) = |\cos x| + 2$ (iii) $f(x) = |x| - |x - 2|$
- Q2. (a) Define continuity from the left and continuity from the right. Test the continuity of $f(x) = \sqrt{2 - x^2}$ on $[-\sqrt{2}, \sqrt{2}]$. 12
 (b) Test the continuity of $f(x) = \begin{cases} x \sin(1/x) & \text{if } x \neq 0 \\ 0 & \text{if } x = 0 \end{cases}$ at $x = 0$. 8
- Q3. (a) Define differentiability of a function $f(x)$ at a point $x = a$. Test the differentiability of $f(x)$ at $x = 1$, where, $f(x) = |x + 1| + |x - 1|$. 12
 (b) Oil spilled from a ruptured tanker spreads in a circle whose radius increases at a rate of 0.75 m/sec. How fast will the area of the circle increase when the radius is 1.25 meter? 8
- Q4. (a) Find the n th derivative of $f(x) = \cos(ax + b)$ 6
 (b) State and prove Leibnitz's theorem. 7
 (c) If $y = (\sin^{-1} x)^2$ then show that 7

$$(1 - x^2)y_{n+2} - (2n + 1)xy_{n+1} - n^2y_n = 0.$$

University of Asia Pacific
Department of Basic Sciences and Humanities
Mid-Semester Examination Spring - 2014
Program: B. Sc Engineering (CE)

Course Title: Physics I
Time: 1.00 Hour

Course Code: PHY-101

Credit: 3.00
Full Mark: 60

N.B- There are **Four** Questions. Answer any **Three**. All questions are of equal value. Figures in the right margin indicate marks.

1. (a) What do you understand by elasticity? Define different types of elastic modulus. [5+5]
- (b) What do you understand by the term Poisson's ratio? Show that the maximum possible value of Poisson's ratio is equal to $\frac{1}{2}$. [10]
2. (a) Define the terms stress and strain. [5+5]
- (b) Prove that in case of longitudinal strain, the work done per unit volume is equal to $\frac{1}{2} \times \text{Stress} \times \text{Strain}$. [10]
3. (a) Show that the kinetic energy of a rotating body is given by the relation $E = \frac{1}{2} I \omega^2$, where the symbols have their usual meanings. [10]
- (b) Derive the following expressions: [5+5]
 - (i) Angular momentum $L = I \omega$
 - (ii) Torque $\tau = I \alpha$where the symbols have their usual meanings.
4. (a) State and explain Brewster's law. At Brewster's angle, prove that the reflected and refracted rays are at right angles to each other. [5+5]
- (b) Give a statement of the law of Malus. How can you establish the following relation: [5+5]

$$I \propto \cos^2 \theta$$

where I is the intensity of light transmitted by the analyzer and θ is angle between the transmission axes of the analyzer and the polarizer.

University of Asia Pacific
Department of Civil Engineering
Mid Semester Examination Spring 2014
Program: B.Sc. Engineering (Civil)

Course Title : Engineering Mechanics II
 Time : 3 hours

Course Code: CE 103
 Full Marks: 10X3=30

(Answer all the questions)

1. Block A weighing 300 N rests over the block B which weighs 900 N. Coefficient of Friction for all contact surfaces is 0.3. What will be the value of the force P that will cause the block B to have impending motion towards right?

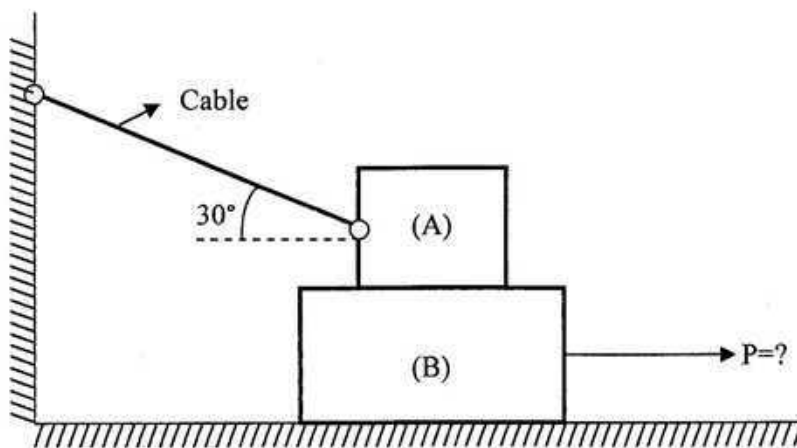

2. The wood handle of the mallet is of 2 ft long; weighs 3.14 lb., and has a uniform cross section. The head, weighing 16.1 lb. is a wood cylinder of diameter 6 inch. Find the mass moment of inertia of the mallet with respect to the y axis.

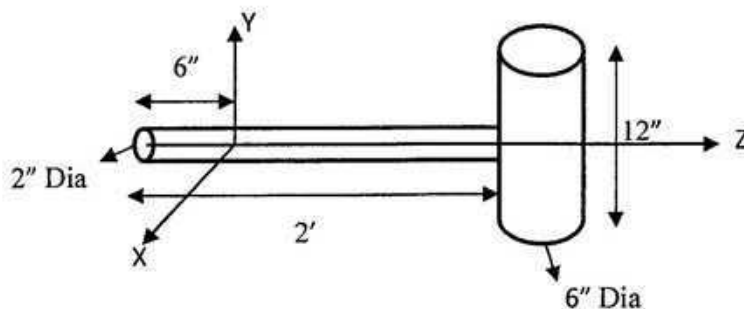

3. The position of a particle which moves along straight line is defined by the relation, $s = t^3 - 6t^2 - 15t + 40$ where s is in ft and t is in second. Determine
- i) the time at which velocity will be zero.
 - ii) the position and distance travelled by the particle at that time.
 - iii) the acceleration of particle at that time.
 - iv) the distance travelled by the particle from 4s to 6s.

University of Asia Pacific
Department of Civil Engineering
Mid term Examination Spring 2014 (Section A)
Program: B.Sc. Engineering (Civil)

Course Title: Surveying
 Time : 1 Hour

Course Code: CE 105
 Full Marks: 40

There are **Five** questions. Answer any **Four**

- 1.(a) Derive an expression for tacheometric surveying when staff is held vertically. 7
- (b) Describe orbit of Earth around Sun with a neat sketch. 3
2. (a) Apply both Prismoidal Rule and Trapezoidal Rule to compute the volume of a 20 ft. deep reservoir 60- ft long and 40ft wide at bottom with a side slope of 1.5 horizontal to 1 vertical on all sides. The ground surface is horizontal in both directions. (See **Figure 1**). 5

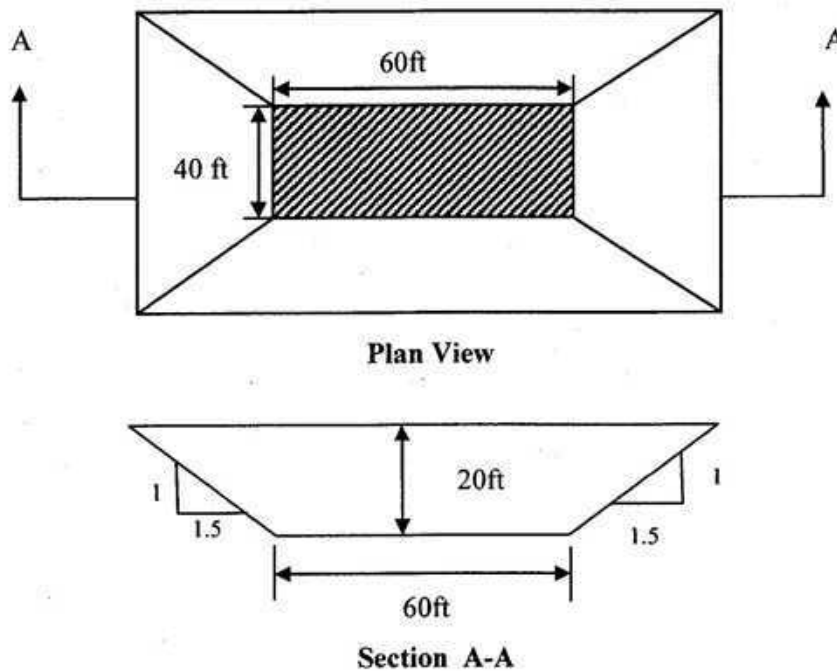
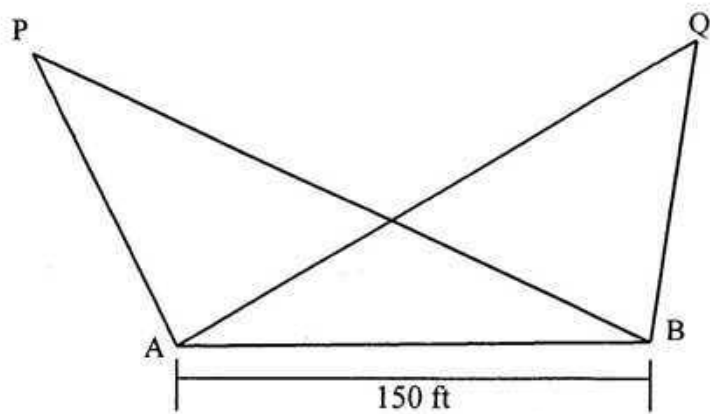

Figure 1

- (b) Derive an expression for *Relief Displacement*. 5
3. (a) A tower structure is located at point P .Readings are taken with two theodolite from two points A and B 120 ft apart .The R.L. of instrument centre at A & B are 25.0ft and 22.0ft respectively. The vertical angle readings from A and B to top tower at P are 30° and 25° respectively. Determine R.L. of top of tower and the distance of the tower. 8
- (b) Explain basic concept of GPS. 2
4. Two tower structures are located at points P & Q .Readings are taken with two theodolite from two points A and B 150 ft apart .Plan view is given in **Figure 2**.The R.L. of instrument centre at A & B are 25.2 ft and 20.4 ft respectively. The vertical angle readings from A to top towers at P & Q are 30° and 25° respectively. Determine the aerial distance between top of towers at P & Q. 10



$$\angle PAB = 130^\circ$$

$$\angle PBA = 45^\circ$$

$$\angle QBA = 112^\circ$$

$$\angle QAB = 55^\circ$$

Figure 2

5. Determine the azimuth and altitude of a star from following data:

10

- i. Declination of a star = $21^\circ 30' \text{ N}$
- ii. Hour Angle of a star = 40°
- iii. Latitude of the observer = 50° N

The University of Asia Pacific
Department of Civil Engineering
Mid Term Examination Spring 2014

Course: CHEM 111
Full Marks: 40

Course Title: Chemistry
Time: 1 Hours

Answer any **Four** questions:

1. a) Define solution. 5
Sketch the physical view of a heterogeneous solution.
- b) Classify solution based on the physical states of solute and solvent. 5

2. a) Distinguish between saturated and super saturated solutions. 5
- b) Discuss the effects of external stresses on the following system: 5

$\text{solid} + \text{H}_2\text{O} \rightleftharpoons \text{saturated solution}$

3. a) What is meant by thermoneutral dissolution? 5
Draw the energy profiles for the exothermic, endothermic and thermoneutral dissolution.
- b) Explain that dissolution of NaCl in water is governed by the electrical forces. 5

4. a) Define solubility. 5
Prove mathematically that concentration of a saturated solution is constant.
- b) Draw the solubility curves of: 5
NaCl, KCl, KNO₃, CaCl₂.6H₂O and Na₂(SO₄).10 H₂O

5. a) What is absorption Co-efficient? 5
Explain Bunsen absorption Co-efficient mathematically.
- b) State and explain Henry's laws related to the mass and volume of gas dissolved in liquid. 5

University of Asia Pacific
Department of CE
Mid Semester Examination (Spring 2014)
Program: B.Sc Engineering
Year: 1st Semester: 2nd

Course Title: English Language II Course Code: HSS 103
Time: 1 Hour

Credit: 3.00
Full Marks: 20

1. Rewrite any six (06) of the following sentences correctly: 03

- a. Shakespeare's use of words (be) extraordinary.
- b. The actor and director (be) injured.
- c. The players along with the coach (be) happy.
- d. The collecting stamps of different countries (be) my favourite hobby.
- e. Not only the students but also the teacher (be) to be praised.
- f. Farid (have hang) the painting on the wall.
- g. The policeman (have lay) the gun down on the floor.

2. Change the form of Voice of any six (06) of the following sentences: 03

- a. Open your book.
- b. That he is an honest person is known to everybody.
- c. Who did he see?
- d. He learns the skill of acrobatic easily.
- e. Who will teach this course?
- f. I shall have been taking exams for the next two weeks.
- g. Arifa has finished the needlework.

3. Change the forms of speeches of any six (06) of the given sentences: 03

- a. I asked her, "Are you taking tea or coffee?"
- b. He said, "I have already read the book".
- c. He said, "I may come tomorrow".
- d. He said to me, "You need not fear the elephant".
- e. I told him, "We are stuck in traffic".
- f. The teacher said to the students, "You ought to follow the rules".
- g. She said, "I went there yesterday".

4. Complete any four (04) of the following sentences using the correct conditional structures: 02

- a. Fahad would do better in the exam
- b. If Shahed had bought the ticket,.....
- c. The team always won the match
- d. If I, I will present you my watch as a gift.
- e., she would have joined us for the dinner.

5. Make sentences with *any six (06)* of the following phrases:

03

- a. Fish out of water
- b. Out of hand
- c. The blink of an eye
- d. Out of the blue
- e. Storm in teacup
- f. A white lie
- g. No hard feelings
- h. Keep an eye on

6. Write one synonym and one antonym of *any two (02)* of the given words and make sentences with those synonyms and antonyms:

02

- a. Deliberate
- b. Cautious
- c. Beneficial

7. Make sentences with *any two (02)* of the following words:

04

- a. Between
- b. Reply
- c. Empty
- Among
- Answer
- Vacant

University of Asia Pacific
Department of Basic Sciences & Humanities
Mid Semester Examination, Spring-2014
Program: B.Sc. Engineering (Civil, 1st year/ 2nd semester)

| | | |
|------------------------------|----------------------|----------------|
| Course Title: Mathematics II | Course Code: MTH 103 | Credit: 3.00 |
| Time: 1 hr | | Full Marks: 60 |

Answer any **THREE** of the following questions: 3×20 = 60

1. (a) Define direction cosines of a line. 5
 (b) A plane meets the co-ordinate axes in A, B, C such that the centroid of the triangle ABC is the point (p, q, r) ; show that the equation of the plane is 15

$$\frac{x}{p} + \frac{y}{q} + \frac{z}{r} = 3.$$

2. Find the length of the Shortest Distance (S.D.) between the lines 20

$$\frac{x-3}{1} = \frac{y-5}{-2} = \frac{z-7}{1} \text{ and } \frac{x+1}{7} = \frac{y+1}{-6} = \frac{z+1}{1}$$

Find also its equations and the point where it intersects the given lines.

3. (a) Show that the lines $x - y + z - 5 = 0, x - 3y + 6 = 0$ and $2y + z - 5 = 0, 4x - 2y + 5z - 4 = 0$ are parallel. 5
 (b) Find the equation of the plane through the intersection of the planes $x + 3y + 6 = 0$ and $3x - y - 4z = 0$ whose perpendicular distance from the origin is unity. 15
4. (a) Write down the general equation of a sphere when centre (a, b, c) and radius r being given. 2
 (b) Find the equations of the two spheres which passes through the circle $x^2 + y^2 + z^2 - 4x - y + 3z + 12 = 0, 2x + 3y - 7z - 10 = 0$ and touches the plane $x - 2y + 2z = 1$. 18

University of Asia Pacific
Department of Civil Engineering
Mid Semester Examination Spring 2014
Program: B. Sc. Engineering (Civil)

Course Title: Engineering Materials
Time: 1 Hours

Course Code: CE 201
Full Marks: 35

There are **FOUR** questions. **Question No. 1** is compulsory. Answer any **TWO** from the rest.

1. (a) For a bridge construction project, a sand sample was collected and sent to the concrete lab of UAP for sieve analysis. The data of sieve analysis are given below: (15)

| Sieve No. | Materials Retained (gm) |
|-----------------|-------------------------|
| 1/2 inch | 25 |
| #4(4.75 mm) | 32 |
| #8(2.36 mm) | 50 |
| #12(1.68 mm) | 65 |
| #16(1.18 mm) | 95 |
| #30 (0.6 mm) | 25 |
| #40 (0.425 mm) | 5 |
| #50(0.3 mm) | 5 |
| # 100 (0.15 mm) | 5 |
| PAN | 15 |

- i) Draw the grading curve of the sand sample.
- ii) Determine the coefficient of uniformity (C_u) and coefficient of curvature (C_z) of the sample.
- iii) Comment on the grading of sample.
2. (a) Draw the predicted strain response curve of the elasto-plastic material for the following loading history. (6)

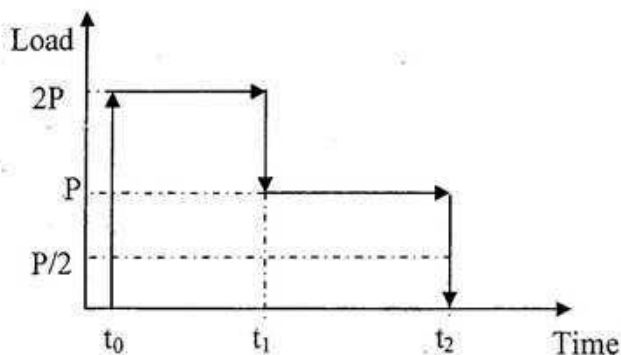

- (b) Durability of bricks depends largely on proper proportioning of alumina and silica- Explain. (3)
- (c) What is the use of frogmark on bricks? (1)
3. (a) Discuss each type of single stage and multi stage loading with appropriate examples and figures. (5)
- (b) Compare flash and false setting of cement (3)
- (c) Write a short note on efflorescence of brick. (2)
4. (a) Compare (i) setting and hardening of cement
(ii) over-burnt and under-burnt brick (2+2=4)
- (b) What changes are necessary in the composition of cement to impart quick setting and rapid hardening property? (3)
- (c) Increases in fineness of cement increases strength and heat liberation- Explain the sentence. (3)

University of Asia Pacific
Department of Civil Engineering
Mid-Term Examination Spring 2014

Course Code: CE 211 (A & B)
 Course Title: Mechanics of Solids I

Time: 1 (one) Hour
 Full Marks: (3x20) = 60

Answer all questions.
Each question carries equal marks

1. Draw Shear Force and Bending Moment Diagram for the following beam loading.

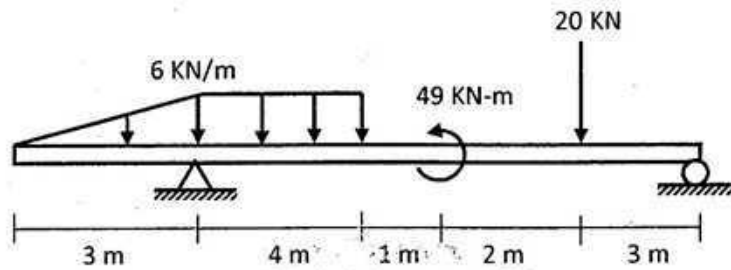

2. Determine the functions for loading, shear and bending moment for the following beam.

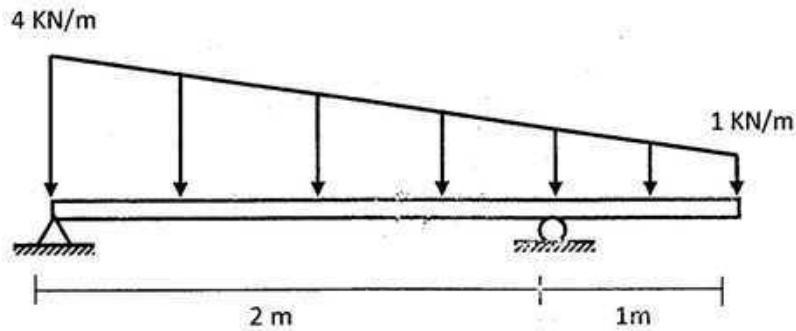

3. Use singularity function to draw SFD and BMD of the beam shown below.

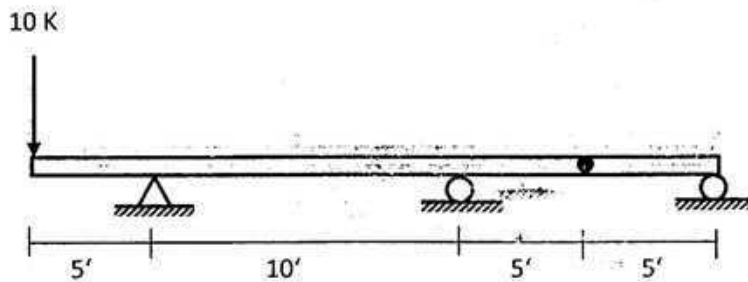

The University of Asia Pacific
Department of Civil Engineering
Mid-Semester Examination, Spring - 2014
Program: B. Sc Engineering (2nd Year/1st Semester)

Course Title: Basic Electrical Engineering
 Time: 1.00 Hours

Course No. ECE 201 Credit Hours: 3.00
 Full Marks: 60

[There are **Four** questions. Answer any **Three**. Figures in the right margin indicate marks]

1. a. Find R_{ab} for the circuit in Figure 1(a)

[10]

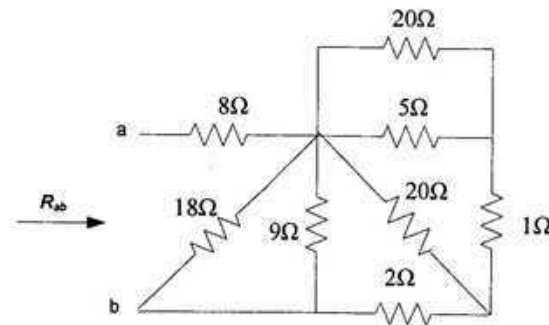

Figure 1(a)

- b. Obtain V_1 and V_2 in the circuit shown in Figure 1(b) using nodal analysis

[10]

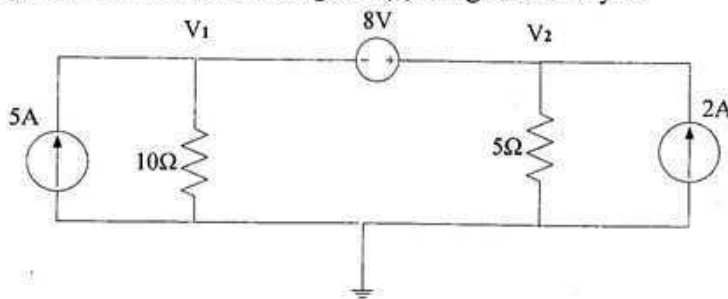

Figure 1(b)

2. a. In the circuit shown below, find v , i and the power absorbed by the 4Ω resistor.

[10]

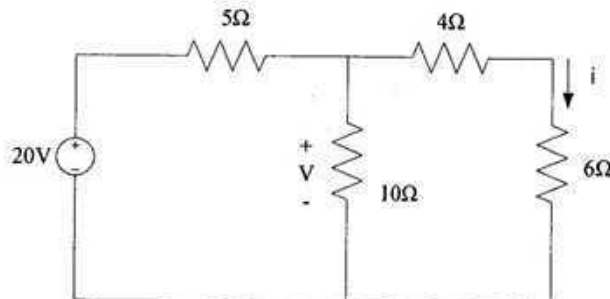

Figure 2(a)

b. Use mesh analysis to find i_1 and i_2 in the circuit shown in figure 2(b)

[10]

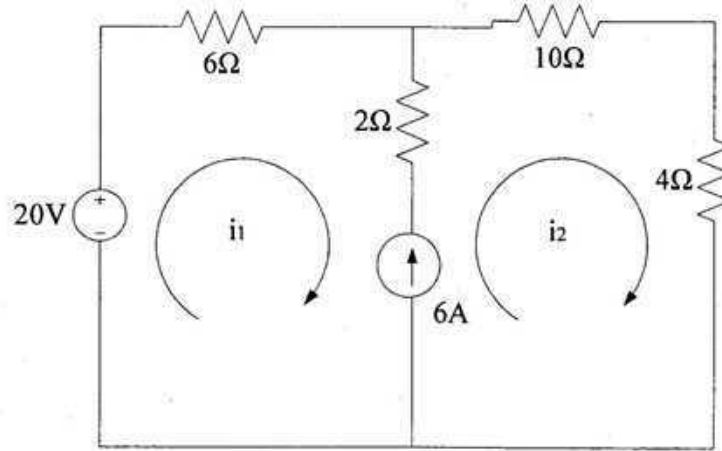

Figure 2(b)

3. a. Calculate V_o using superposition for the circuit shown in figure 3(a)

[10]

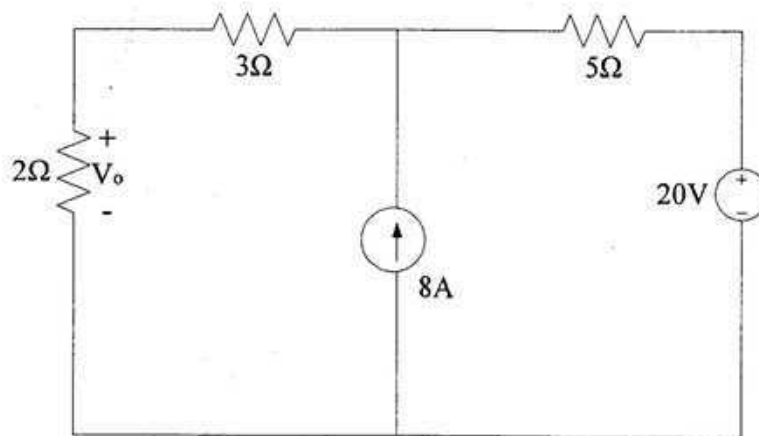

Figure 3(a)

b. State Kirchhoff's current Law and from this, derive the current division formula for parallel resistance connection. [10]

4. a. State Maximum Power Transfer Theorem and prove it. And also show that the expression of maximum power transferred to the load is $P_{max} = \frac{V_{Th}^2}{4R_{Th}}$ [15]

b. Write Short notes on the following terms, [05]
i. Short Circuit
ii. Open Circuit

University of Asia Pacific
Department of Basic Sciences and Humanities
Mid Semester Examination, Spring 2014
Programme: B. Sc.Engineering (Civil)
(2nd Year 1st Semester)

Course Title: Bangladesh Studies: Society and Culture Course Code: HSS 211(a)

Credit: 2.00

Time: 1 Hour

Full Marks: 40

There are FIVE questions. Answer ANY FOUR (4x10)

1. Define sociology. How can sociology help us in our lives? 3+7
2. What are the branches of sociology? Discuss the relation between aging and society. 3+7
3. What is social stratification? Distinguish between class and caste. 3+7
4. Define culture. What are the elements of culture? What are the differences between culture and civilization? 2+2+6
5. What is the academic definition of family? What are the types of family? Give examples from Bangladesh. 2+6+2

University of Asia Pacific
Department of Basic Sciences and Humanities
Mid Semester Examination, Spring - 2014
Programme: B.Sc. Engineering (CIVIL)
2nd year 1st semester

Course Title: Bangladesh Studies: History
Credit: 2.00

Course Code: HSS 211(b)

Time: 1 Hour

Full Marks: 40

There are FIVE questions below. Answer ANY FOUR (4 x 10)

1. Write in brief about the background of the name 'Bangladesh'.
2. Which dynasty ruled Bengal for 400 years? Who was the founder of this dynasty? How did he come to power?
3. Who offered all facilities to Sri Chaitannya in his religious propagation? What do you know about his literary appreciation and role in spreading Islam?
4. Who were the Bara Bhuiyans? How did the Mughals at last suppress them?
5. What were the Janapadas? What are the present locations of different Janapadas of ancient Bengal?

University of Asia Pacific
Department of Basic Sciences & Humanities
Mid Semester Examination, Spring-2014
Program: B.Sc. Engineering (Civil, 2nd year/ 1st semester)

Course Title: Mathematics III
Time: 1 hr

Course Code: MTH 201

Credit: 3.00
Full Marks: 60

Answer any **THREE** of the followings questions:

3×20 = 60

1. (a) Define inverse of a matrix. Does the inverse of a square matrix always exist? (10)

Make your comments. Find A^{-1} and show that $A^{-1}A = I$ for the matrix $A = \begin{pmatrix} 1 & -5 \\ 0 & -1 \end{pmatrix}$.

- (b) Solve for the following system of linear equations by using matrix method. (10)

$$2x_1 - 2x_2 + x_3 = 3$$

$$3x_1 + x_2 - x_3 = 7$$

$$x_1 - 3x_2 + 2x_3 = 0$$

2. (a) Solve the following system by using Gauss- Jordan Elimination. (10)

$$5x - 3y + 2z = 13$$

$$2x - y - 3z = 1$$

$$4x - 2y + 4z = 12$$

- (b) Find the rank of the matrix A where (10)

$$A = \begin{pmatrix} 1 & 3 & 1 & -2 & -3 \\ 1 & 4 & 3 & -1 & -4 \\ 2 & 3 & -4 & -7 & -3 \\ 3 & 8 & 1 & -7 & -8 \end{pmatrix}$$

3. (a) Define linear combination. Determine whether or not the vector $(1, 2, 6)$ is a linear combination of the vectors $(2, 1, 0)$, $(1, -1, 2)$ and $(0, 3, -4)$. (10)

- (b) Define linear dependence and independence of vectors. Determine whether the vectors $(1, -2, 1)$, $(0, -1, 0)$ and $(2, 0, 2)$ in R^3 are linearly dependent or independent. (10)

4. (a) Determine the value of a such that the following system of equations x, y and z has: (i) a unique solution, (ii) no solution (iii) more than one solution (15)

$$ax + y + z = 1$$

$$x + ay + z = 1$$

$$x + y + az = 1$$

- (b) Given that $A = \begin{pmatrix} 1 & 2 & -3 \\ 5 & 0 & 2 \\ 1 & -1 & 1 \end{pmatrix}$ and $B = \begin{pmatrix} 1 & 3 \\ 2 & -1 \\ 0 & 4 \end{pmatrix}$, find AB' and BA' if possible. (5)

University of Asia Pacific
Department of Civil Engineering
Midterm Examination Spring 2014

Course # : CE-203

Course Title: Engineering Geology & Geomorphology

Full Marks: 40 (10 X 4 = 40)

Time: 1 hour Credit: 3 hours

Answer any four (4) questions of your choice out of the following five (5)

- 1a) Mention the principal zones of the earth from geologic point of view. Describe any one. 5
- 1b) Draw a schematic diagram showing thicknesses of geosphere/lithosphere. 3.5
- 1c) Provide two examples of each type of rocks. 1.5
- 2a) Define geomorphic process? Distinguish between physical and chemical weathering processes. 1+3=4
- 2b) Define precipitation, infiltration and percolation. Mention names of factors affecting runoff. 3+3=6
- 3a) Mention the factors affecting co-efficient of runoff. 2
- 3b) For the following basin, x is a constant factor. For what value of x, the flow rate (Q) will be the maximum (peak) for the basin? Find the FF and CC of the basin for maximum runoff. 8

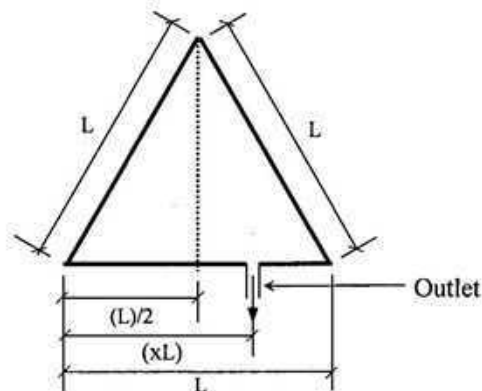

- 4a) Classify fold and fault (mention names only). Draw a neat sketch of an oblique fault. 4
- 4b) Mention few factors influencing drainage pattern. 2
- 4c) Sketch and mention major features of dendritic pattern of drainage. 4
- 5) Using the information provided below, calculate d for the catchment area as shown below. 10

Intensity of Rainfall: 2.25 inch/hour Assume L & h in yard
 Q_p : 0.712 m³/s

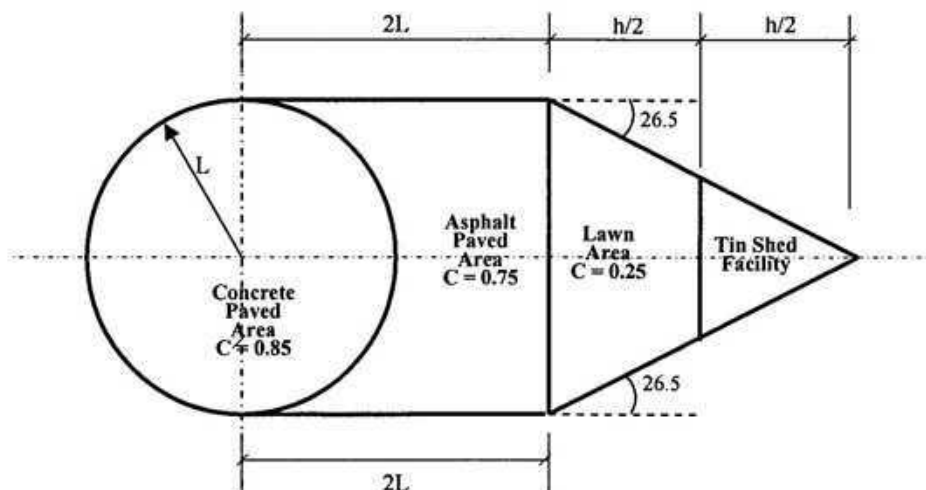

University of Asia Pacific
Department of Civil Engineering
Mid Semester Examination Spring 2014

Course #: CE 205
Full Marks: 20

Numerical Analysis and Computer Programming
Time: 1 hr

1. Determine the root of the equation $x^3 - x - 1 = 0$ by Newton-Raphson method correct upto 5 decimal places. [05]

2. Use Gauss Jordan method to solve the following system of linear equation. [05]

$$\begin{aligned}2x + 5y - z &= 6 \\x - 6y + 9z &= 17 \\3x - 11y - 5z &= 13\end{aligned}$$

3. Use Cramers Rule to solve the following system of linear equation. [05]

$$\begin{aligned}2x + y + z &= 3 \\x - y - z &= 0 \\x + 2y + z &= 0\end{aligned}$$

4. Fit the curve $Y = aX^b$ to the following data and determine X_7 . [05]

| DATA | |
|------|------|
| X | Y |
| 1 | 1200 |
| 2 | 900 |
| 3 | 600 |
| 4 | 200 |
| 5 | 110 |
| 6 | 50 |
| 7 | |

University of Asia Pacific
Department of Civil Engineering
Mid Semester Examination Spring 2014 (Set A)

Course #: CE 213

Course Title: Mechanics of Solids II

Full Marks: 40 (= 4 × 10)

Time: 1 hour

1. For the Mohr's circle of stress shown in Fig. 1,

- (i) Calculate the normal stress σ_{yy} and shear stress τ_{xy} on a plane where normal stress $\sigma_{xx} = -6$ ksi.
- (ii) Identify the stresses on the Mohr's circle.
- (iii) Calculate the angle (α) for principal plane and show both principal planes on the Mohr's circle.

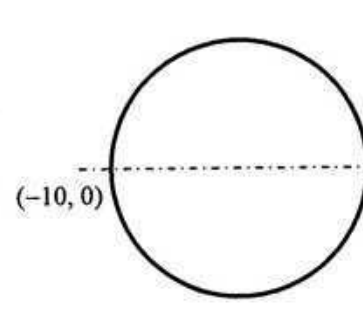

Fig. 1

2. For the beam ABC loaded as shown in Fig. 2, calculate the

- (i) Maximum torsional shear stress in the beam section,
- (ii) Deflection of spring C if it has shear modulus = 12000 ksi, coil diameter = 1", inside diameter of spring = 5", number of coils = 6.

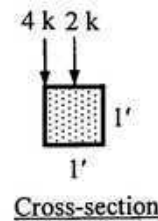
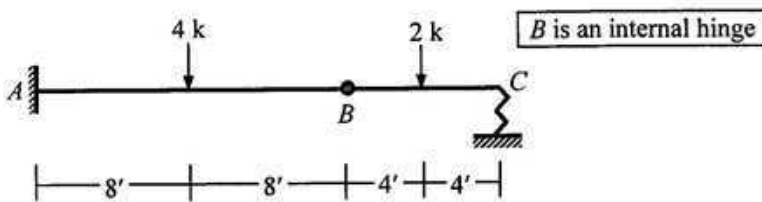

Fig. 2

3. Fig. 3 shows the reaction forces (R_y , R_z) and moments (M_x , M_y , M_z) at support a and d of goal-post abcd subjected to forces $F_y = F_z = P$ at the midspan of bc.

If $L = 24'$, $H = 8'$, $G = 12000$ ksi with cross-section of members as shown, calculate the

- (i) Allowable value of P if the allowable torsional shear stress at the post ab is 10 ksi,
- (ii) (1) Maximum Torsional rotation, (2) Maximum combined shear stress, for post ab for the value of P calculated in (i).

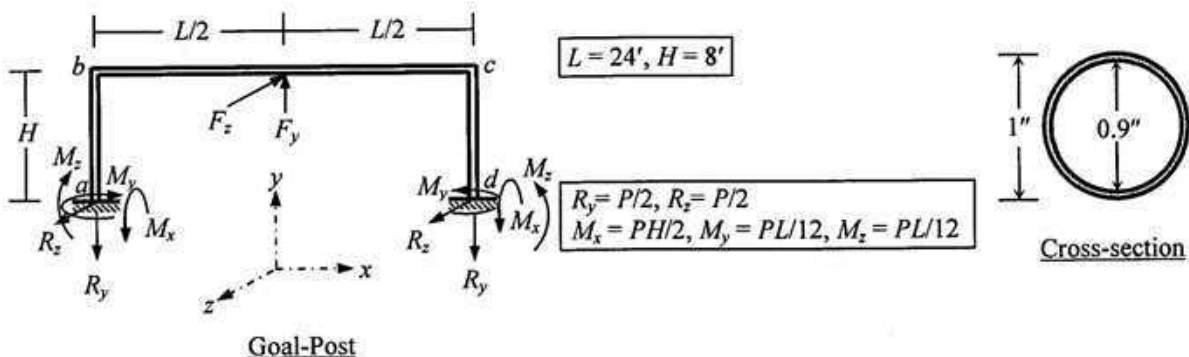

Fig. 3

4. For goal-post abcd subjected to forces as shown in Fig. 3 and as described in Question 3, calculate the

- (i) Force P needed to cause maximum compressive stress of 20 ksi at the post cd,
- (ii) Maximum tensile stress at the post cd for the value of P calculated in (i).

University of Asia Pacific
Department of Civil Engineering
Mid Term Examination Spring 2014

Course Title: Fluid Mechanics
Time: 1.0 hour

Course No: CE 221
Full Marks: 40

*[The symbols have their usual meanings]
[The figures at the right margin indicate full marks]*

SECTION-A

(There are **THREE** questions in this section. Answer any **TWO** questions.)

1(a) Define center of pressure. Derive the expression for center of pressure of a submerged plane surface. (8)

(b) Show the relationship among Absolute Pressure, Atmospheric Pressure and Gage Pressure with a neat sketch. (2)

2. Find the horizontal and vertical forces acting on the gate AB as shown in Figure 1. The gate is a quadrant of a circle of radius 3 m. The length of the gate perpendicular the plane of the paper is 2 m. At what angle will the resultant force be acting to the horizontal? (8)

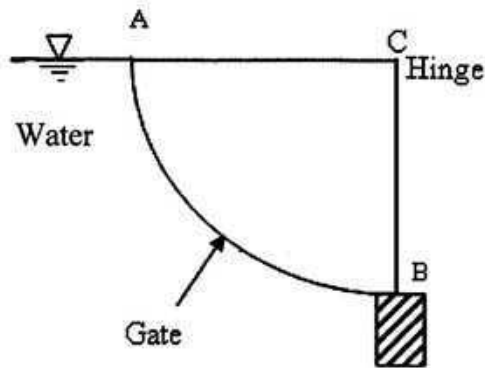

Figure 1

(b) Differentiate between the following terms: (2)
i. Piezometer and manometer
ii. Cohesion and adhesion.

3 (a) A capillary tube having an internal diameter of 6 mm is dipped into water at 20°C. Determine the height of capillary rise. Take $\theta = 30^\circ$ and $g = 9.81 \text{ m/s}^2$. Given $\sigma = 0.0728 \text{ N/m}$ and $\rho = 998 \text{ kg/m}^3$ at 20°C. (2)

(b) The density and kinematic viscosity of a fluid at 20°C are 1.32 gm/cm³ and 18 stokes, respectively. Calculate the velocity gradient and intensity of shear stress at a distance 4 cm from the lower plate. Given that the fluid is filled between two parallel plates 8 cm apart and the upper plate is moving at a velocity of 120 cm/s, the lower one being stationary. Assume the velocity distribution is given by $u = 120 - k(8 - y)^2$. (8)

Section- B

(There are **THREE** questions in this section. Answer any **TWO** questions.)

1 (a) Define the following terms: (2x2=4)
(i) Mass flow rate
(ii) Steady flow

1 (b) In a laminar flow through a circular pipe, the velocity profile is a parabola whose equation is given below. Show that mean velocity is equal to half of the maximum velocity. (6)

$$u = u_m \left[1 - \frac{r^2}{r_0^2} \right]$$

2 (a) An oil ($S = 0.85$, $\nu = 1.9 \times 10^{-5} \text{ m}^2/\text{s}$) flows in a 25 cm diameter pipe at 0.90 L/s. Determine the type of flow. (3)

2 (b) A velocity potential for a 2-D flow is given by $\phi = x + y + 3$. Calculate the stream function and also find the flow rate between the streamlines passing through two points A (1,2) and B (2,4). (5+2=7)

3 (a) Define flow net with a neat sketch. State its uses and limitations. (4)

3 (b) For the following velocity vector, determine the magnitude of acceleration at A ($x = -3$, $y = 2$, $z = -1$, $t = 3$). (6)

$$V = (2t - 3y)i + y^2 j - \frac{z}{3} k.$$

University of Asia Pacific
Department of Civil Engineering
Mid-Term Examination, Spring-2014
Program: B.SC Engineering (Civil)

Course Title: Principle of Economics

Course Code: ECN 201

Credit: 2.00

Time: 1 Hour

Full Marks: 20

Answer any **four** from the following questions:

1. (a) Explain the law of supply graphically. (3)

(b) Find the equilibrium price and quantity from the following markets: (2)

$$Q_d = 100 - 2P, Q_s = -50 + 2P$$

2. Explain the Diminishing Law of Marginal Rate of Substitution. (5)

3. (a) Explain the diminishing law of marginal product. (3)

(b) Given the demand function, $P_d = 145 - Q^2$ and supply function, $P_s = (Q+1)^2$ (2)

Find the Consumers' Surplus and Producers' Surplus.

4. Calculate the cross price elasticity of demand between Tea and Coffee (5)

Here Tea is good 1 and Coffee is good 2

| | Before | | After | |
|--------|------------|------------------------|------------|------------------------|
| | Price [Tk] | Quantity [Units/month] | Price [Tk] | Quantity [Units/month] |
| Tea | 30 | 40 | 50 | 10 |
| Coffee | 45 | 15 | 40 | 45 |

5. How can one get ATC curve from AFC and AVC curve. Show graphically. (5)

University of Asia Pacific
Department of Basic Sciences & Humanities
Mid Semester Examination, Spring-2014
Program: B. Sc. Engineering (Civil, 2nd year/ 2nd semester)

Course Code: MTH 203
Full Marks: 60

Course Title: Mathematics IV

Credit: 3.00
Time: 1(one) hour

Answer any **THREE** of the following questions: 3×20 = 60

1. (a) State and prove first shifting property. (8)

(b) If $L\{F(t)\} = f(s)$, prove that $L\{F''(t)\} = s^2 f(s) - sF(0) - F'(0)$. (12)

2. (a) Obtain the Laplace transform of $18 \cos^2 4t$. (8)

(b) Evaluate $L\left\{\int_0^t \frac{1 - e^{-2x}}{x} dx\right\}$. (12)

3. (a) Find $L^{-1}\left\{\frac{s-2}{(s-2)^2+5^2} + \frac{s+4}{(s+4)^2+9^2} + \frac{1}{(s+2)^2+3^2}\right\}$. (10)

(b) Evaluate $L^{-1}\left\{\frac{s-2}{(s-2)^2+5^2} + \frac{4}{(s-4)^5}\right\}$. (10)

4. Find the inverse Laplace transform of $\frac{2s+1}{(s^2+1)(s^2+s+1)}$. (20)

University of Asia Pacific
Department of Civil Engineering
Midterm Examination (Spring 2014)
Program: B.Sc. Engg (3rd year 1st semester)

Course Title: Principles of Accounting
Full marks : 20

Course: ACN 301

Credit Hours: 2.0
Time : 1 hr

[Answer all Questions]

Q.1. Jay Cutler owns and manages an engineering consultancy firm, which had the following trial balance on December 31, 2013 (the end of its fiscal year).

MEGA CONSULTANTS LTD.
Trial Balance
December 31, 2013

| | <u>Debit</u> | <u>Credit</u> |
|---------------------|--------------|---------------|
| Cash | 8000 | |
| Accounts Receivable | 15000 | |
| Supplies | 13000 | |
| Prepaid Rent | 3000 | |
| Equipment | 20000 | |
| Accounts Payable | | 19000 |
| Owner's Capital | | 40000 |
| Total | 59000 | 59000 |

Summarized transactions for January 2014 were as follows.

- i. Advertising costs paid in cash, \$1,000.
- ii. Additional supplies acquired on account \$4,200.
- iii. Cash collected from customers in payment of accounts receivable \$14,000.
- iv. Cash paid to creditors for accounts payable due \$15,000.
- v. Consulting services performed during January: for cash \$6,000; on account \$9,000.
- vi. Salaries for January paid in cash, \$3,500.
- vii. Jay's drawings during January were \$3,000.

Mega Consultants Ltd. uses the following chart of accounts: No. 101 Cash, No. 112 Accounts Receivable, No. 126 Supplies, No. 130 Prepaid Rent, No. 140 Equipment, No. 201 Accounts Payable, No. 301 Owner's Capital, No. 304 Owner's Drawing, No. 400 Service Revenue, No. 726 Salaries Expense, and No. 729 Rent Expense.

Instructions:

- a. Prepare journal entries to record each of the January transactions. (Omit explanations and date)
- b. Prepare cash ledger account. (Treat December's balance from the given trial balance as opening balance)

(7+3)

Q.2. KL Construction Company is under contract to build a hotel at a contract price of \$3,500,000. The building will take 18 months to complete at an estimated cost of \$2,500,000. Construction began in November 2011, and was finished in April 2013. Actual construction costs incurred in each year were: 2011, \$250,000; 2012, \$1,375,000; and 2013, \$875,000.

Instruction:

Compute the gross profit to be recognized in each year keeping in mind revenue recognition and matching principles.

(5)

Q.3. At the end of its first month of operations, Watson Consultants ltd. has the following adjusted trial balance on December 31, 2012. (in '000BDT)

| | <u>Debit</u> | <u>Credit</u> |
|------------------------------------|--------------|---------------|
| Cash | 6,700 | |
| Accounts Receivable | 900 | |
| Prepaid Insurance | 1,000 | |
| Supplies | 900 | |
| Equipment | 15,000 | |
| Notes Payable | | 5,000 |
| Accounts Payable | | 1,510 |
| Watson, Capital | | 14,000 |
| Watson, Drawing | 600 | |
| Service Revenue | | 14,500 |
| Rent Revenue | | 800 |
| Salary Payable | | 600 |
| Interest Payable | | 50 |
| Unearned Rent | | 500 |
| Salaries Expense | 9,600 | |
| Depreciation Expense | 350 | |
| Accumulated depreciation-Equipment | | 350 |
| Rent Expense | 1,500 | |
| Supplies Expense | 200 | |
| Utilities Expense | 510 | |
| Insurance Expense | 50 | |
| Total | <u>37310</u> | <u>37310</u> |

Instruction:

Prepare an income statement for the month ended December 31, 2012.

(5)

University of Asia Pacific
Department of Civil Engineering
Mid Term Examination Spring 2014
Program : B.Sc Engineering (Civil)

Course Title: Structural Engineering I
 Time : 1 hr

Course Code : CE 311
 Full Marks : 40
 3-1 (B)

(ANSWER ALL 3 QUESTIONS)

1. Draw AFD, SFD and BMD of the members **ab** and **bc** of the following Frame: (10)

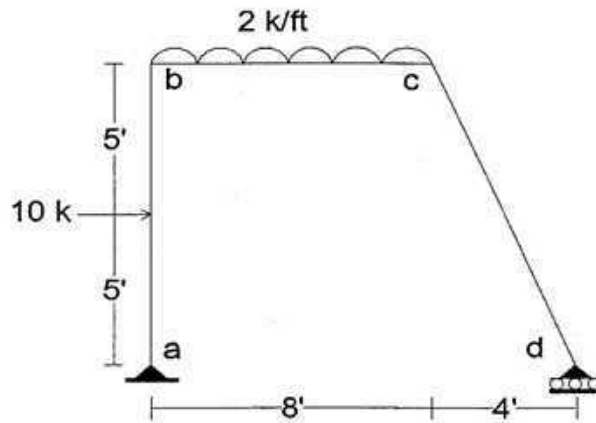

2. Draw Influence Line of the following beam for: (20)
 (i) R_c, R_e (ii) V_b, V_d, V_{eL}, V_{eR} (iii) M_b, M_d, M_e, M_g

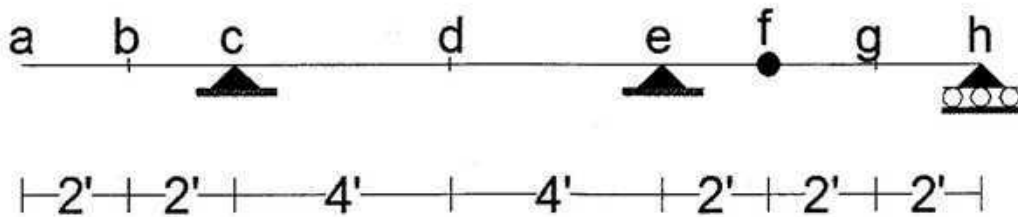

3. Draw Influence Line of the following Plate Girder for (10)
 (i) R_b, R_f (ii) FBR_a, FBR_b, FBR_e (iii) V_{bd} (iv) M_d

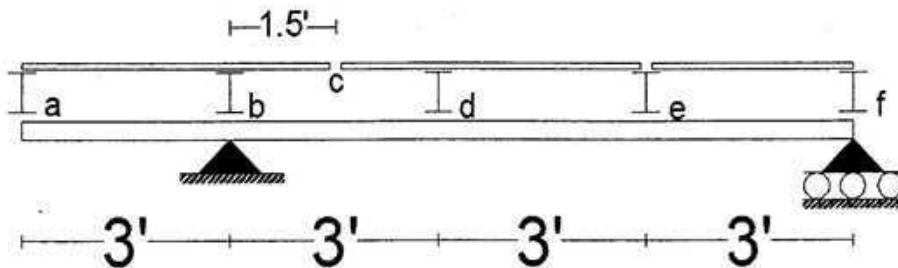

University of Asia Pacific
Department of Civil Engineering
Mid Term Examination Spring 2014
Program : B.Sc Engineering (Civil)

Course Title: Design of Concrete Structure I
 Time : 1 hr

Course Code : CE 315
 Full Marks : 30
 3-1 (A)

(There are 5 questions. Answer all of them)

1. Write down **basic design principle of USD method.** (2)
2. Compute the **resisting moment** of the following beam using **transformed section** if, $f_s = 24000$ psi and $f_c = 1800$ psi. (8)

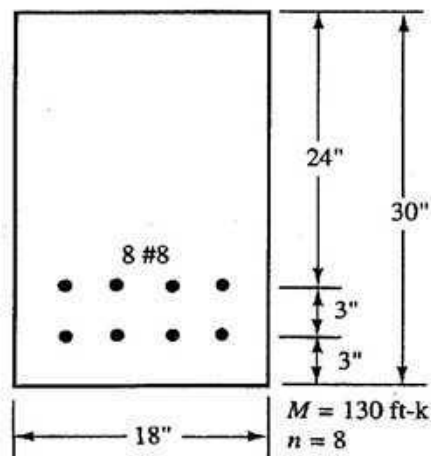

3. A **rectangular beam** is to be designed using $f'_c = 4$ ksi and $f_y = 60$ ksi. This beam experiences a **uniformly distributed DL of 2.5 k/ft** (including beam self wt.) and a **concentrated 20 kip LL**. Use, $b = 14$ " and #10 bar. (10)

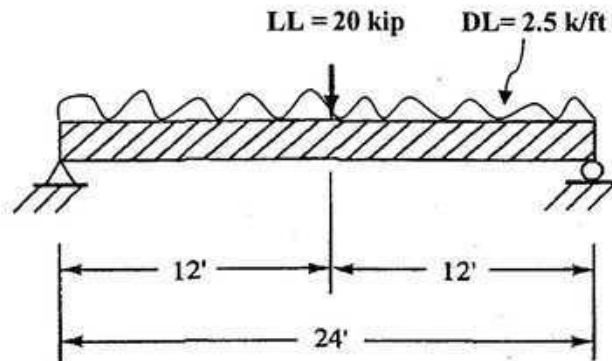

$$\text{Use } \rho = \frac{0.18 f'_c}{f_y}$$

4. Calculate the **Effective flange width** of both **L-shaped beam** at the left and **T-shaped beam** at middle (Figure shown below). Given, Beam span = 18 ft. Also, calculate the value of β_1 , if $f'_c = 4500$ psi. (6)

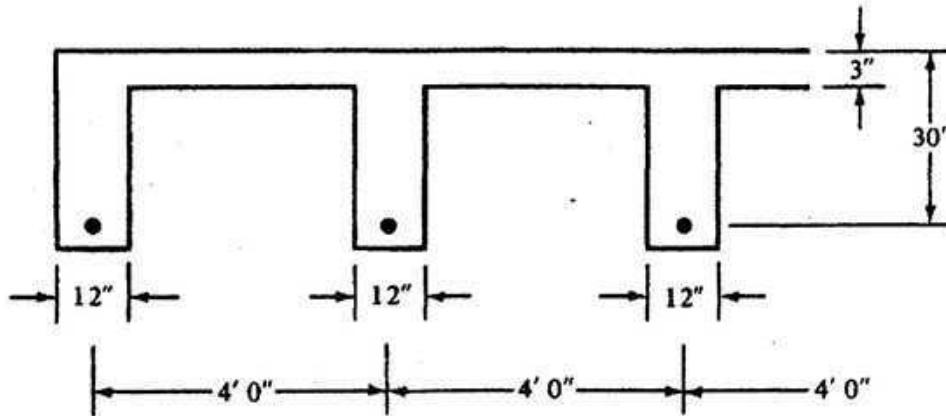

5. Write the purpose of ϕ factor and Load factor. Why load factor is greater for live load than dead load? (4)

Formula's Given:

$$\phi M_n = M_u = \phi A_s f_y d \left(1 - \frac{1}{1.7} \frac{\rho f_y}{f'_c} \right)$$

$$\rho = \frac{0.85 f'_c}{f_y} \left(1 - \sqrt{1 - \frac{2 R_n}{0.85 f'_c}} \right)$$

$$\phi = 0.65 + (\epsilon_t - 0.002) \left(\frac{250}{3} \right)$$

$$R_n = \frac{M_u}{\phi b d^2} = \rho f_y \left(1 - \frac{1}{1.7} \frac{\rho f_y}{f'_c} \right)$$

$$\beta_1 = 0.85 - \left(\frac{f'_c - 4000}{1000} \right) (0.05) \geq 0.65$$

$$a = \frac{A_s f_y}{0.85 f'_c b} = \beta_1 c$$

$$\phi M_n = \phi A_s f_y \left(d - \frac{a}{2} \right)$$

University of Asia Pacific
Department of Civil Engineering
Mid Semester Examination Spring 2014
Program: B. Sc. Engineering (Civil)

Course Title: Environmental Engineering I
Time- 1 hour

Course Code: CE 331
Full marks: 40

Answers all the questions below:

1. (a) Define the types of aquifer (with figure). (6+3)

A 100 mm diameter tubewell is sunk 35 m below static groundwater level. The depth of water in the tubewell while pumping is 33m. The radius of drawdown is 30 m and the coefficient of permeability of the aquifer is 0.5 l/s/m^2 . Calculate the probable discharge of the well.

- (b) Define screen transmitting capacity. (1+3)

A fully penetrating well in a confined sandy aquifer has a maximum transmitting capacity of 1200 l/min. the aquifer is overlain and underlain by impervious formations. The thickness of the aquifer is 20 m. design the length of the well screen, assuming the percentage of open area in the available strainer to be 15% and bore hole dia as 15 cm. [Assume safe entrance velocity 2 cm/sec, since k for sands is usually 0.04 cm/sec]

- (c) A 20 ft long, 14-pipe size, continuous –slot stainless steel screen is to be installed in a well. The width of the outside wrapping wire used to fabricate the screen is 0.156 in and the recommended slot size is 0.065 in. The anticipated yield is 2000 gpm. Justify the design of a well. (10)

[On a 36-in diameter screen, the wire face width would have to be increased to 0.215 in to maintain adequate strength]

2. (a) Table shows the population of a country during the years 2006 - 2010, in ten years intervals. (a) Find the equation of the least square parabola fitting the data. (b) Compute the trend values for the years in the table below and compare with the actual values. (c) Estimate the population of the community in the year 2004 and 2013 (10)

| Year | 2006 | 2007 | 2008 | 2009 | 2010 |
|-------------------------------|------|------|------|------|------|
| Pop ⁿ (million) | 200 | 230 | 280 | 350 | 450 |

- (b) Water has to be supplied to a town with one lakh population at the rate of 150 liters per (7)

capita per day from a river 2000 m away. The difference in elevation between the lowest water level in the sump and the reservoir is 36m. If the demand has to be supplied in 8 hours, determine the size of the main and the brake horse power of the pumps required. Assume maximum demand as 1.5 times the average demand. Assume $f=0.0075$, velocity in the pipe = 2.4 m/sec and efficiency of the pump= 80%.

The necessary equations and data are given below:

- I. Water Horse Power = $(\gamma_w \cdot Q \cdot H) / 0.735$
- II. Brake Horse Power = Water Horse Power / (efficiency of pump) x (efficiency of motor)

University of Asia Pacific
Department of Civil Engineering
MidTerm Examination
Spring 2014
Program: B.Sc. Engineering (Civil)

Course Title: Geotechnical Engineering I

Course Code: CE 341

Time: 1 hour

Full Marks: 20

Answer all the questions.

(4x5=20 marks)

1. a) Classify the following soil. The properties of the subgrade soil are found as follows. 3
 - Percent finer than 0.075 mm = 25%
 - Percent finer than 0.425 mm = 30%
 - Percent finer than 0.6 mm = 32%
 - Percent finer than 4.75 mm = 75%
 - Liquid limit = 60%
 - Plastic limit = 30%

b) In a dispersion test, soil particles in the suspension settled in three layers. In the graduated jar, the first layer (2 inch thick) was formed in 15 seconds, the second layer (4.8 inch thick) was formed in 4 minutes and the particles in the top layer (3 inch thick) took 4 days to be settled. Calculate the percentage of sand, silt and clay in the soil mixture. 2
2. a) Name different types of fine grained and coarse grained soil structures. 2

b) What are the effective size, uniformity coefficient and coefficient of curvature for the given soil? Given that, Percent finer than 0.075 mm = 10%; Percent finer than 0.425 mm = 30%; Percent finer than 0.6 mm = 32%; Percent finer than 4.75 mm = 60% 3
3. a) Calculate the water content of a partially saturated soil sample when degree of saturation is 75%. Given that, specific gravity is 2.7 and void ratio is 0.55. 1

b) A circular area of radius 2 m is loaded with a uniform pressure of 75 kN/m². Calculate the following:

 - (i) Calculate stress in the soil mass at depth 3 m below the centre of the loaded area.
 - (ii) Obtain the exact depth (below the centre of the loaded area) at which stress reduces to 20% of the applied stress. 4

Given, $N_{CC} = \left[1 - \left\{ \frac{1}{1 + \frac{a}{z}} \right\}^{3/2} \right]$
4. A 8m deep bed of clay soil is underlying a 6 m deep sand bed (Figure 1). The water table is located at 6m from the ground level. Given that top 2 m of sand layer is dry. Calculate total stress, effective stress and pore water pressure at the top and the middle of the saturated clay layer. 5

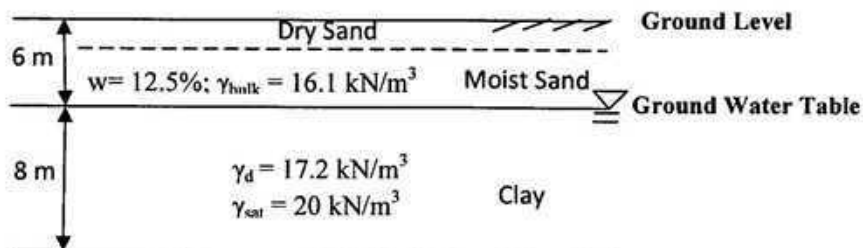

Figure 1

University of Asia Pacific
Department of Civil Engineering
Mid Semester Examination, Spring 2014

Course Code: CE 361
 Course Title: Open Channel Flow

Full Marks: 60
 Time: 1 hour

There are four (4) questions. Answer any **three (3)** questions ($20 \times 3 = 60$)

1. (a) Define Specific Energy. Show that "At the critical state of flow, the specific energy is the minimum for a given discharge". [2+5=7]
 (b) Explain why it is undesirable to design channels at or near the critical state? [3]
 (c) A circular channel 3.0 m diameter carries a discharge of $6.0 \text{ m}^3/\text{s}$. Compute the critical depth and velocity assuming $\alpha = 1.15$. Use Trial and Error Method. [10]

2. (a) What do you mean by wide channel? Show that for a wide channel the Hydraulic Radius is approximately equal to the depth of flow. [5]
 (b) The current meter readings (m/s), width and total depth of different points of a certain river section are given in the following figure and table. Compute the discharge and mean velocity of the entire section. [15]

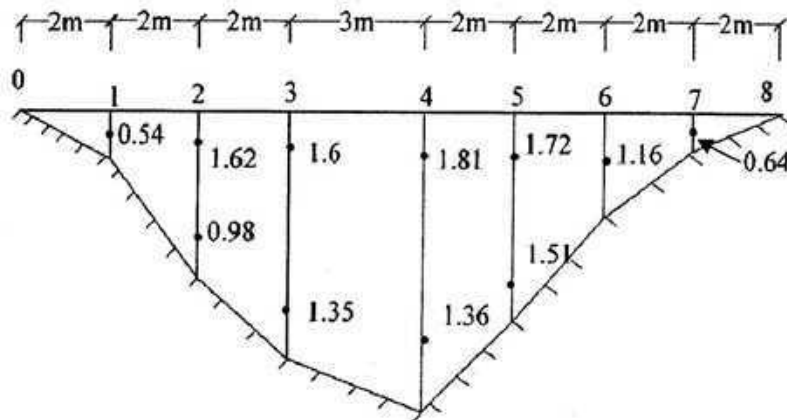

| Gauge Location | Total Depth (m) |
|----------------|-----------------|
| 0 | 0 |
| 1 | 1.5 |
| 2 | 4.0 |
| 3 | 5.7 |
| 4 | 6.8 |
| 5 | 4.9 |
| 6 | 2.7 |
| 7 | 1.3 |
| 8 | 0 |

3. (a) Derive a general expression for Hydraulic Exponent (M) for Critical Flow Condition. By using the derived expression, compute the hydraulic exponent (M) for a trapezoidal channel with $b = 10 \text{ m}$, $s = 2$ and $h = 2 \text{ m}$. [6+4=10]
 (b) Water flows at a velocity of 1.50 m/s and a depth of 1.80 m in a long rectangular channel which is 4.0 m wide. If the critical depth is 0.91 m , compute the height of a smooth upward step in the channel bed to produce critical flow. Also calculate the depth of flow produced by a smooth upward step of 0.40 m . Assume $\alpha = 1.0$ [5+5=10]

4. (a) Explain: (i) Prismatic and Non-Prismatic channel (ii) Small and Large Slope Channel [4]

(b) The alternate depths in a rectangular channel 8 m wide are 2.5 m and 1.35 m. Compute the discharge and the specific energy. [6]

(c) Using the Trapezoidal Rule of numerical integration, compute discharge per unit width, the mean velocity and the numerical values of α and β for the following velocity measurements (u is the velocity at a distance z from the channel bottom) along a vertical in a wide channel, when the total depth is 6.0 m. [10]

| | | | | | | | |
|----------------|-----|-----|-----|-----|-----|-----|-----|
| z (m) | 0.0 | 1.0 | 2.0 | 3.0 | 4.0 | 5.0 | 6.0 |
| u (m/s) | 0.0 | 2.0 | 3.0 | 2.8 | 3.5 | 4.0 | 4.3 |

Given Formula

| | | |
|---|----------------------------|--|
| $\bar{U} = \frac{\int_0^A u \, dA}{A}$ $\alpha = \frac{\int_0^A u^3 \, dA}{\bar{U}^3 A}$ $\beta = \frac{\int_0^A u^2 \, dA}{\bar{U}^2 A}$ | Trapezoidal channel | Circular Channel |
| | $A = (b + sh)h$ | $h = \frac{d_0}{2} \left[1 - \cos \frac{\omega}{2} \right]$ |
| | $P = b + 2h\sqrt{1 + s^2}$ | $\omega = 2\cos^{-1} \left(1 - \frac{2h}{d_0} \right)$ |
| | $B = b + 2sh$ | $A = (\omega - \sin\omega) \frac{d_0^2}{8}$ |
| | | $B = d_0 \sin \frac{\omega}{2}$ |
| | | $P = \frac{\omega d_0}{2}$ |
| | | <i>Note that ω is in radian</i> |

University of Asia Pacific
Department of Civil Engineering
Mid Term Examination Spring 2014
Program: B.Sc. Engineering (Civil)

Course Title: Design of Concrete Structures II
 Time: 1 hr

Course Code: CE 317
 Full Marks: 3x15=45

[Answer all the questions]

1. a) What are the differences between one-way slabs and two-way slabs? Discuss the significance of the limitation laid by ACI for long span/short span should be less than 2 for two-way slab design. (5)
- b) Use WSD to design the following slab system shown in Fig. 1, supported by 12"x12" beam all around and 12"x12" column. Calculate the required reinforcements and show them in neat sketches (draw plan showing the reinforcements) [Given, FF = 30 psf, PW = 40 psf, LL = 80 psf, $f'_c = 3$ ksi and $f_y = 60$ ksi, $f_s = 24$ ksi, $n = 9$, $k = 0.378$, $j = 0.874$]. (10)

$$\begin{array}{lll}
 +C_{A(DL)} = 0.027, & +C_{A(LL)} = 0.032, & -C_A = 0.071 \\
 +C_{B(DL)} = 0.033, & +C_{B(LL)} = 0.035, & -C_B = 0.00
 \end{array}$$

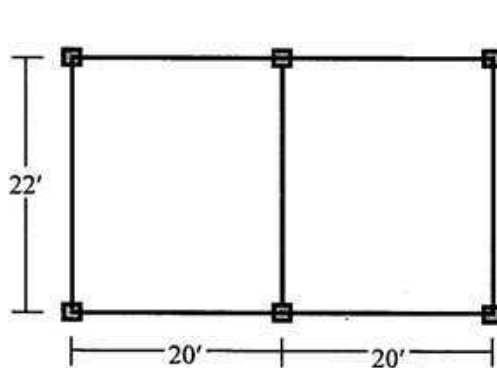

Fig. 1

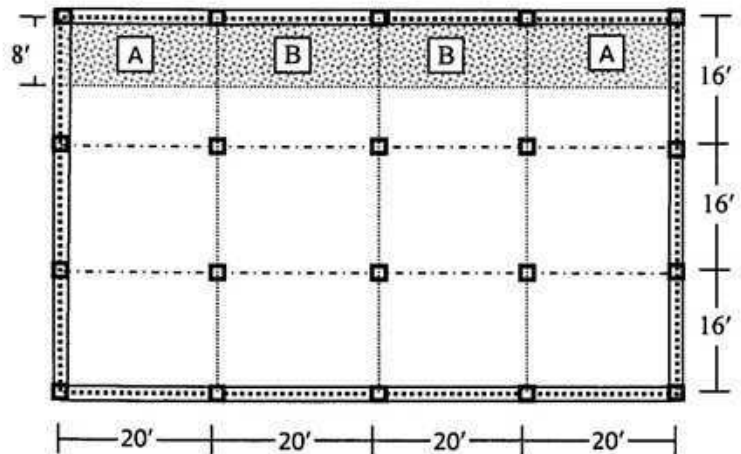

Fig. 2

2. A building is to be designed as a flat plate structure. A plan of the building (supported on 12"X10" edge beams) is shown in Fig. 2. All columns are 12"X12". Use WSD to calculate the column strip and middle strip moments and reinforcements of slab A [Given, $\alpha_1 = 3.7$ and $\beta_1 = 1.8$, FF = 25 psf, RW = 30 psf, LL = 50 psf, $f'_c = 4$ ksi, $f_y = 60$ ksi, $k = 0.375$, $j = 0.875$ and $f_s = 24$ ksi]. (15)
3. a) Why ties are provided in columns? Write down the rules for placing ties in tied columns according to ACI. (5)
- b) Using USD method design a spiral column for a DL = 600^k and LL = 300^k. [Given: $f'_c = 3$ ksi and $f_y = 60$ ksi and $f_{s,all} = 20$ ksi and steel ratio is 2%] (10)

University of Asia Pacific
Department of Civil Engineering
Mid Semester Examination Spring 2014
Program: B.Sc. Engineering (Civil)

Course Title: Environmental Engineering II
Time- 1 hour

Course Code: CE 333
Full marks: 60

Answer all of the questions below

Assume reasonable value for any missing data (if applicable)

1. (a) Compare the advantages of pour-flush latrines over simple pit latrines. (5)
(b) Design a double chamber septic tank for a family of 10 persons with a desludging interval of 6 years. The average wastewater flow is 90 lpcd. Due to space constraint, tank area should not exceed 12 m^2 . Assume wastewater temperature within the tank to be 25°C . Also design the soak pit for the disposal of septic tank effluent into sandy loam soil. Draw neat sketches for septic tank and soak pit. (15)

2. (a) Briefly explain the suitable conditions of separate and combined sewerage system. (3+3)
(b) Estimate the maximum daily design flow from a composite area with the given land use pattern and condition as follows: (14)
(i) an residential area of 5 hectares, occupied by 200 people/ha having an average waste water generation rate of 80 lpcd. Consider the infiltration rate to be 150 lpd per meter over the sewer length of 15 m, including the house connections.
(ii) a 5 hectare buissness district employing 300 people and generating 100 liter per capita of waste water per day.
Time of concentration for the composit area is 25 minutes and the runoff coefficient can be taken as 0.75. The rainfall curve is given by: $I \text{ (cm/hr)} = 101.6 / (t + 20)$.

3. (a) What are the basic differences between on-site and off-site sanitation systems? (5)
(b) Define – (i) Sullage (ii) Municipal sewage (2)
(c) Using the Nomogram, given in Fig. 1, determine the required sewer pipe diameter for discharging the maximum domestic sewage flow, generated by 15000 people having an average water supply of 110 lpcd. The pipe is to be laid on the slope of 0.003 and the Manning's coefficient is to be considered as 0.013. Also estimate the allowable discharge and flow velocity in the sewer flowing $\frac{1}{4}$ th of the full depth, where the ratio for discharge and velocity are 0.2 and 0.8 respectively. (13)

Table 1: Design Values for Long-term Infiltration Rates for Wastewater into Various Soils

| Soil Type | Long term infiltration rate, I (l/m ² -day) |
|-------------------------------------|---|
| Sand | 50 |
| Sandy loam | 30 |
| Porous loam, porous silty clay loam | 20 |
| Compact silty loam, clay | 10 |

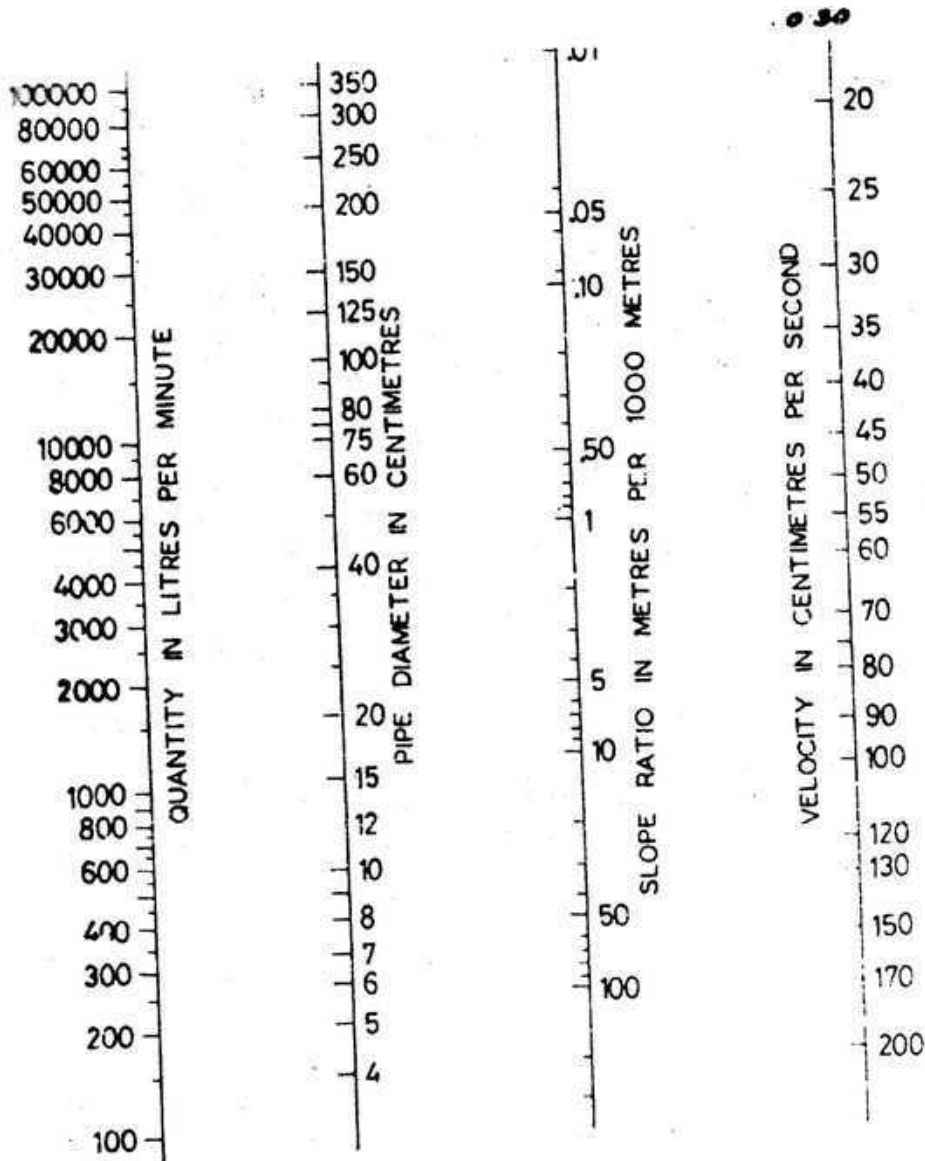

Fig 1: Nomogram based on Manning's formula for circular pipes (for n = 0.013) running full

University of Asia Pacific
Department of Civil Engineering
Midterm Examination
Spring 2014
Program: B.Sc Engineering (Civil)

Course Title: Transportation Engineering I
 Full Marks: 40

Course Code: CE 351
 Time: 1 hour

There are **Three** questions. Answer two of them

1. a) The following data were observed for 5 vehicles traversing 4 mile segment of a highway. Calculate the Time Mean Speed and the Space Mean Speed of the vehicles. 6

| Vehicle | Time (min) |
|---------|------------|
| 1 | 3.7 |
| 2 | 2.8 |
| 3 | 3.6 |
| 4 | 2.9 |
| 5 | 3.3 |

- b) What are the different types of Delays? Discuss any one of them. 6
 c) Compare angular and parallel method of parking. 8

2. a) The following spot speeds (km/hr) were observed for 30 vehicles traversing a segment of a highway. 13
 40,31,49,63,45,63,54,46,70,32,44,43,37,47,44,58,52,56, 68,64,35, 39, 42, 55, 48, 38, 34, 43, 37, 66.
 Calculate the design speed, average speed, safe speed, median speed and lower limit of speed.

- b) What are the dynamic characteristics of vehicles that affect the road design? 5
 c) What is PIEV time? 2

3. a) Calculate the AADT for the following data. Data collection was conducted on Wednesday in June. MEF for June is 0.578. 8

| Hour | Volume |
|------------------|--------|
| 6:00-7:00 a.m. | 500 |
| 7:00-8:00 a.m. | 665 |
| 8:00-9:00 a.m. | 820 |
| 9:00-10:00 a.m. | 680 |
| 10:00-11:00 a.m. | 600 |

- b) Write down the objectives of traffic volume study? 6
 c) What are the common data collection techniques for Origin-Destination (O-D) Survey 6

Table 1 Hourly Expansion Factors for a Rural Primary Road

| Hour | Vol. | HEF | Hour | Vol. | HEF |
|----------------------|------|-------|------------------|------|------|
| 6:00-7:00 a.m. | 294 | 42.01 | 6:00-7:00 p.m. | 743 | 16.6 |
| 7:00-8:00 a.m. | 426 | 28.99 | 7:00-8:00 p.m. | 706 | 17.5 |
| 8:00-9:00 a.m. | 560 | 22.05 | 8:00-9:00 p.m. | 606 | 20.4 |
| 9:00-10:00 a.m. | 657 | 18.8 | 9:00-10:00 p.m. | 489 | 25.3 |
| 10:00-11:00 a.m. | 722 | 17.11 | 10:00-11:00 p.m. | 396 | 31.2 |
| 11:00-12:00 p.m. | 667 | 18.52 | 11:00-12:00 a.m. | 360 | 34.3 |
| 12:00-1:00 p.m. | 660 | 18.71 | 12:00-1:00 a.m. | 241 | 51.2 |
| 1:00-2:00 p.m. | 739 | 16.71 | 1:00-2:00 a.m. | 150 | 82.3 |
| 2:00-3:00 p.m. | 832 | 14.84 | 2:00-3:00 a.m. | 100 | 124 |
| 3:00-4:00 p.m. | 836 | 14.77 | 3:00-4:00 a.m. | 90 | 137 |
| 4:00-5:00 p.m. | 961 | 12.85 | 4:00-5:00 a.m. | 86 | 144 |
| 5:00-6:00 p.m. | 892 | 13.85 | 5:00-6:00 a.m. | 137 | 90.2 |
| Total daily volume = | | 12350 | | | |

Table 2 Daily Expansion Factors for a Rural Primary Road

| Day of Week | Volume | DEF |
|-----------------------|--------|--------|
| Sunday | 7,895 | 9.515 |
| Monday | 10,714 | 7.012 |
| Tuesday | 9,722 | 7.727 |
| Wednesday | 11,413 | 6.582 |
| Thursday | 10,714 | 7.012 |
| Friday | 13,125 | 5.724 |
| Saturday | 11,539 | 6.51 |
| Total weekly volume = | | 75,122 |

University of Asia Pacific
Department of Civil Engineering
Mid Semester Examination Spring 2014

Course # : CE 363

Course Title: Engineering Hydrology

Full Marks:60

Time: 1 hours

Answer all question

1. What is residence time? Assuming that all the water in the oceans is involved in the hydrological cycle; calculate the average residence time of ocean water. Use the following data. (6)
 - Volume of ocean water = 1 338 000 000 km³
 - Precipitation rate = 458 000 km³ /yr on ocean
 - Precipitation rate = 119 000 km³ /yr on land
 - Evaporation = 505 000 km³ /yr from ocean
 - Evaporation = 72 000 km³ /yr from land
2. At a climate station, the following measurements are made: air temperature = 15°C, relative humidity = 35%, calculate the vapor pressure, specific humidity and air density. Assume standard atmospheric pressure = 101.3 kPa. (6)
3. Discuss briefly the various abstractions that take place from the precipitation. (6)
4. List the various data that are needed to use Penman's equation for estimating the potential evapotranspiration from a given area. (5)
5. List different factors affect the evaporation from a water body. (5)
6. The shape of a catchment area can be described by joining points though straight line of the following coordinates (described in km): (0,0), (16, 8), (32, 0), (24,16), (32, 32), (16, 24), (0, 32), (8, 16),(0, 0). There are four rain gauge stations in the catchment whose coordinates are (12, 12), (12, 20), (20, 12), (20,20) and the annual rainfall recorded are 120,175,120 and 200 respectively. Find the mean precipitation for the given catchment by Thiessen polygon method. (10)
7. Explain (any two): (4x2=8)
 - (a) methods for estimating the missing rainfall data at a station in a basin.
 - (b) method for testing the consistency of rainfall records at a station and necessary adjustment.
 - (c) how you would determine the optimum number of rain-gauges in a given basin.

8. Distinguish between (any two):

(3x2=6)

- a) Actual and potential evapotranspiration
- b) Field capacity and permanent wilting point
- c) Dalton's Law and Hortons's equation

9. Explain Φ - index. An isolated storm in a catchment produced a runoff of 3.5 cm. Average rainfall depth over the catchment was as below: (8)

| | | | | | | | |
|-------------------------|---|-----|------|------|------|-----|------|
| Time from beginning (h) | 0 | 1 | 2 | 3 | 4 | 5 | 6 |
| Accumulated rain (cm) | 0 | 0.5 | 1.65 | 3.55 | 5.65 | 6.8 | 7.75 |

Calculate the Φ - index.

University of Asia Pacific
Department of Civil Engineering
Mid Term Examination Spring 2014
Program: B.Sc. Engineering (Civil)

Course Title: Principles of Management
Time: 1 Hour

Course Code: IMG301
Full Marks: 20

- | | | |
|------|--|---|
| 1(a) | What is meant by Management? | 1 |
| (b) | Briefly describe the four phases of Management | 2 |
| 2(a) | What do you understand by Planning? | 1 |
| (b) | What are the five key stages in planning process? | 2 |
| 3(a) | What is the difference between effective and efficient? | 1 |
| (b) | What management skills does a Top level Manager need most? Why? | 1 |
| 4(a) | Briefly describe various types of organizational structures with graphical sketch. | 2 |
| (b) | What is the disadvantage of Matrix structure? | 1 |
| 5(a) | Give examples of programmed and non-programmed decision | 1 |
| (b) | Briefly describe each type of decision making style | 3 |



- | | | |
|------|---|---|
| 6(a) | Why is motivation important for an organization? | 2 |
| (b) | Describe Expectancy Theory with example | 2 |
| (c) | Give some examples of organizations that use Theory X and provide your logical support. | 1 |

University of Asia Pacific
Department of Civil Engineering
Mid Term Examination Spring 2014
Program: B.Sc. Engineering (Civil)

Course Title: Project Planning and Management
 Time: 1 Hour

Course Code: CE401
 Full Marks: 20

- 1(a) What are the elements of a legal contract? 1
 (b) Why do we need written contract? 2
 (c) In which type of contract, owner has high risk? Give your reasons? 1
 (d) Name some essential information in 'Invitation For Tender' 2
- 2(a) Give examples of positive and negative stakeholders of a project. 1
 (b) What is WBS? Why WBS is important? 2
 (c) In your judgment, which is the most important phase of Project life cycle? Why? 1.5
 (d) Describe what you understand from the following graph: 1

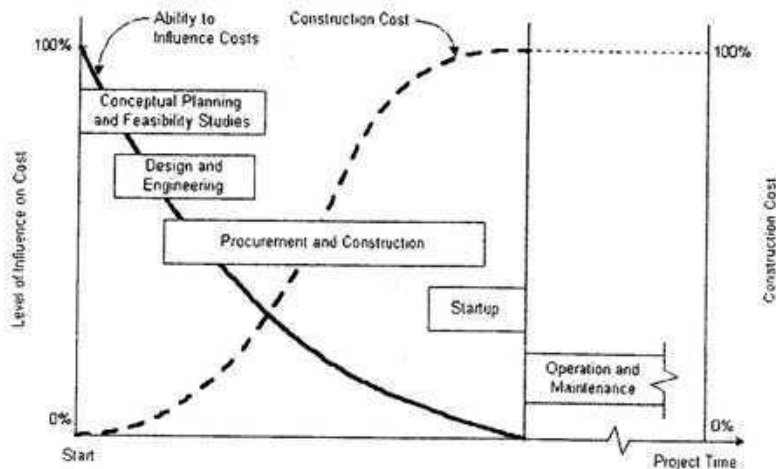

- 3(a) When will you use CPM instead of PERT? 1
 (b) Draw the network diagram, Determine Critical Path and Total Duration of a Project from the following information: 4.5

| Activity | Precedence activity | Duration (Days) |
|----------|---------------------|-----------------|
| A | - | 8 |
| B | - | 9 |
| C | A | 9 |
| D | A, B | 4 |
| E | A | 6 |
| F | C | 5 |
| G | C, D, E | 7 |

- 4(a) What is the difference between Quality Assurance and Quality Control? 1
 (b) What is the difference between Traditional Quality Control and Modern Quality Control? 2

University of Asia Pacific
Department of Civil Engineering
Mid-Term Examination, Spring 2014

Course # CE 441
 Full Marks: 40 (10 X 4 = 40)

Course Title: Geotechnical Engineering II
 Time: 1 hour

Answer any four (4) of the following five (5) questions

1. (a) Define geotechnical sub-surface exploration. Mention (names only) the steps of field investigation phase of a geotechnical subsurface exploration program. 2
- (b) Write down any three (3) general guidelines used for the selection of depths of boreholes. 3
- (c) Mention the names of four drilling/boring techniques used for making exploratory boreholes. Also mention the one, most frequently used in Bangladesh. Mention its reason. 3
- (d) Write down the names of any five (5) in-situ testing performed in the field under the field investigation phase of a sub-surface exploration program. Which one is most commonly used? 2
2. (a) Discuss, in brief, the occurrence of disturbance during sampling. 4
- (b) Mention the preliminary information that should be available to conduct a subsurface exploration program for a building project. 1
- (c) Write short notes on any two of the following: (i) Wash Boring (ii) Logging (iii) Site reconnaissance 5
3. A preliminary geotechnical site investigation was conducted at a site, in Bangladesh, as shown below. Determine cohesion and angle of internal friction at corresponding depths (for both boreholes) of the cohesive and cohesionless deposits, respectively, based on the available data (Use empirical correlations as provided in Appendix). Use hammer efficiency as 54%. 10

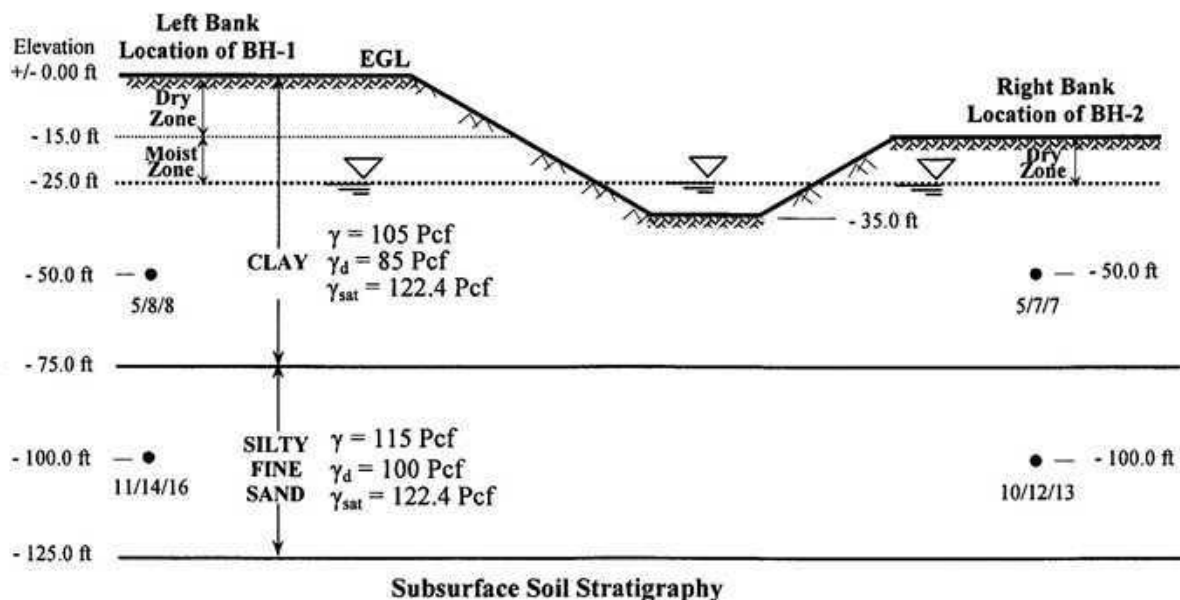

4. Using general bearing capacity equation, determine the size of the individual column rectangular spread footing for the following condition. Use F. S. = 2.5.

10

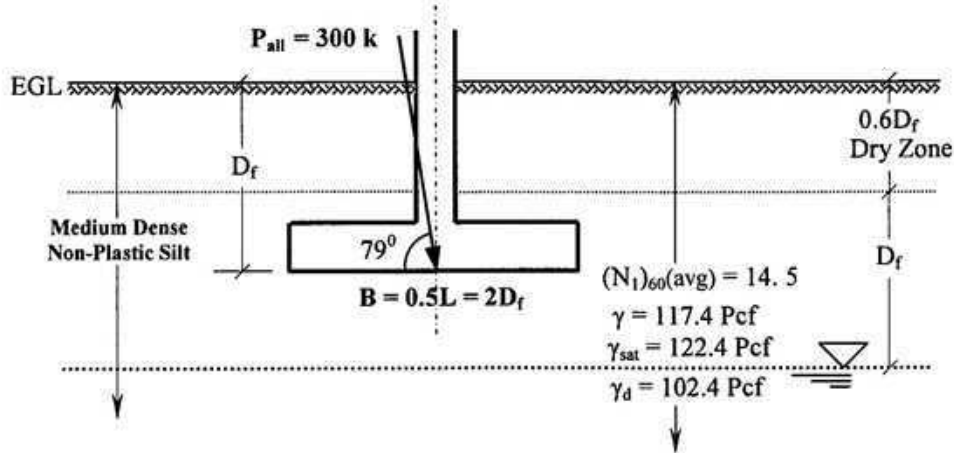

5. (a) Write down the advantages of general bearing capacity equation over Terzaghi's bearing capacity Equations. 3
- (b) During a field investigation SPT-N values were obtained at each 5-foot depth intervals. Using Terzaghi's bearing capacity equation (as appropriate), calculate the allowable column load of the individual column square spread footing for the following condition. Use FS = 3. 7

NOTES:

- No laboratory tests were conducted to obtain the shear strength of the clay formation. So, use empirical correlation (thumb) to estimate the average shear strength below the foundation level and use that for estimating preliminary allowable column load.
- Assume $CF_{60} = 1.0$

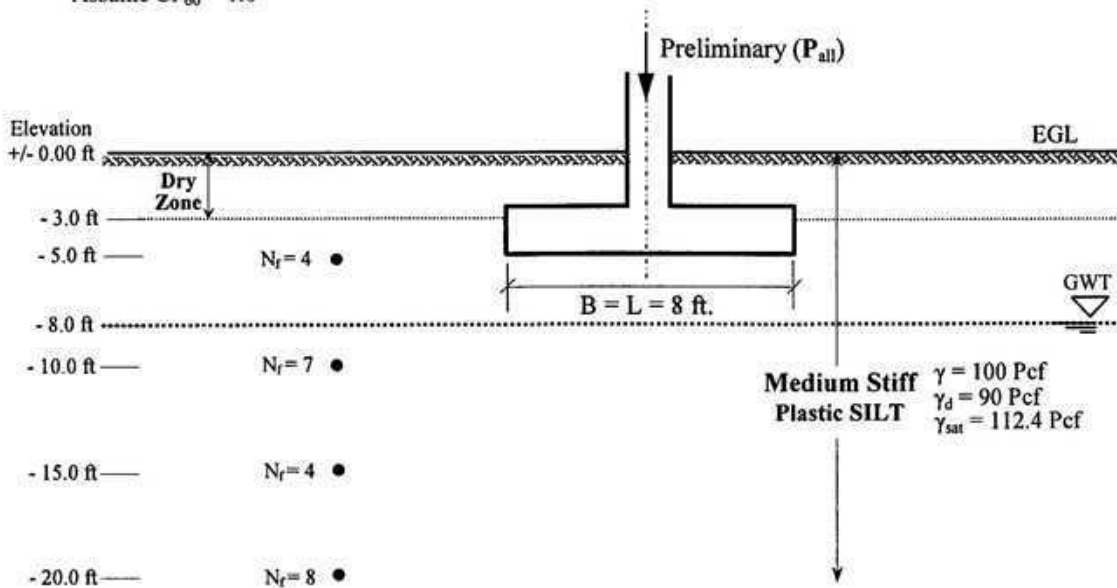



University of Asia Pacific
Department of Civil Engineering
Course No. & Title: CE 451 & Transportation Engineering II
Course Teacher: Md. Jahedul Alam

Total Marks: 40

Time: 1 hour

Answer all of the questions.

1. (a) Write down the functions of Surface, Base, and Sub-base course. 4.0
(b) A 4 lane divided highway is to be constructed on a new alignment. Traffic volume forecasts indicate that the average annual daily traffic (AADT) in both directions during the first year of operation will be 15,000 with the following vehicle mix and axle loads: 6.0

Passenger cars (1100 lb/axle) = 48%
2-axle single-unit trucks (6500 lb/axle) = 40%
3-axle single-unit trucks (8500lb/axle)= 12%

The vehicle mix is expected to remain the same throughout the design life of the pavement. If the expected annual traffic growth rate is 5% for all vehicles, determine the ESAL, given a period of 20 years.
2. (a) Write down the design principle of flexible pavement with neat sketches. 4.0
(b) Draw the most realistic contact area for an 18 ton tandem axle load with a tire pressure of 120 psi. 6.0
3. (a) Briefly explain the different types of stresses in rigid pavement. 6.0
(b) List the name of laboratory tests for highway aggregate. 2.0
(c) What are the factors affecting the pavement design? 2.0
4. (a) Make a comparison between the flexible and rigid pavement. 4.0
(b) A flexible pavement for an urban interstate highway is to be designed using AASHTO design method to carry a design ESAL 3×10^6 . It is estimated that it takes about a week for water to be drained from within the pavement and the pavement structure will be exposed to moisture level approaching saturation for 25% of the time. 6.0

The following additional information are available:

Resilient modulus of asphalt concrete at 68° F= 450000 psi

CBR values of base course materials= 98

CBR values of sub-base course materials= 24

CBR values of sub-grade materials=7

Initial Serviceability Index, $P_i = 4.5$

Initial Serviceability Index, $P_i = 2.0$

Determine a suitable pavement structure and make a neat sketch of the layers.

University of Asia Pacific
Department of Civil Engineering
Midterm Examination Spring 2014
Program: B.Sc. Engineering (Civil)

Course code: CE 461

Course title: Irrigation and Flood Control

Time: 60 Minutes

Total marks: 20

Answer all questions

1. Write the benefits of irrigation and the harmful effects of excess irrigation. (1.5)
2. A sample of water from a well showed that it has an electrical conductivity of 1 mmhos/cm and a density of 1 gm/cm³. A field with a bulk density of soil of 1.48 gm/cm³ and saturation point of 36 percent will be irrigated. Find out the depth of irrigation that may turn the 30 cm depth of soil saline ignoring the precipitation and leaching of salts that may occur. (2.5)
3. Explain the precautions needed while using saline water in irrigation. (2)
4. a) Explain sub-surface irrigation system along with sketch? (1)
b) Explain furrow irrigation method along with sketch. (1)
5. Determine the time required to irrigate a strip of land of 600 m² in area from a tube-well with a discharge of 0.05 m³/second. The infiltration capacity of the soil may be taken as 1 millimeter/minute and the average depth of flow on the field as 200 millimeter. (2.5)
6. a) Draw the average monthly discharge hydrographs for Ganges River (at Hardinge Bridge) and Brahmaputra River (at Bahadurabad) for the period 1956-1979. (2)
b) Based on the hydrographs for the Ganges and Brahmaputra, explain the flood-prone seasons for Ganges and Brahmaputra rivers basins. (1.5)
7. Explain the delta formation process and how delta formation process relates to flood. (2)
8. Write six reasons of floods in Bangladesh. (2)
9. Explain soil moisture tension and soil moisture stress. (2)

University of Asia Pacific
Department of Civil Engineering
Mid Semester Examination, Spring 2014

Course Code: CE 403
Course Title: Professional Practices and Communication

Full Marks: 60
Time: 1 hour

There are Three (3) questions. Answer all the questions (20×3=60)

1. (a) What is a Project? What are the characteristics of a Project? [1+4=5]
(b) Discuss Project Classification based on (i) Ownership and (ii) Funding [3+3=6]
(c) "Justification of a government project is not measured in terms of financial loss and gain only" – Explain this statement with example. [3]
(d) What are the desired attributed of a civil engineering graduate? Name the important skills that an engineer requires to possess to become successful in his career. [4+2=6]
2. (a) What is DPP? Explain three stages of DPP from preparation to approval. [1+3=4]
(b) Draw the flow diagram for preparation and approval procedures of DPP. [6]
(c) Write short notes on (i) Project Definition Phase (ii) Project Delivery Phase [5]
(d) Briefly Explain: (i) Contingency Plan (ii) Poverty Reduction Strategy Paper [5]
3. (a) When does the meeting of ECNEC take place? What are the functions of Executive Committee of the National Economic Council? [1+4=5]
(b) What is MDG? Write down the eight goals of MDG. [1+4=5]
(c) Briefly discuss Stakeholder Consultation in Environmental Impact Assessment of a development project. [3]
(d) What are the typical stages of a construction project? [3]
(e) What do you mean by Over-estimation of Economic Benefits? Briefly explain it with mitigation measures for Padma Bridge Project. [4]

University of Asia Pacific
Department of Civil Engineering
Mid Term Examination Spring 2014
Program: B.Sc. Engineering (Civil)

Course Title: Structural engineering V (Prestressed Concrete)
 Time: 1 hr

Course Code: CE 415
 Full Marks: 60

1. A post-tensioned bonded concrete beam (Fig: 1) has a prestress of 1600 kN in the steel immediately after prestressing and due to losses it reduces to 1300 kN. The beam carries two live loads of P each in addition to its own weight of 3.5 kN/m. Under final condition when the losses have taken place and with full live load the bottom fiber stress is +3.16 MPa by first concept. Determine the value of P . (20)

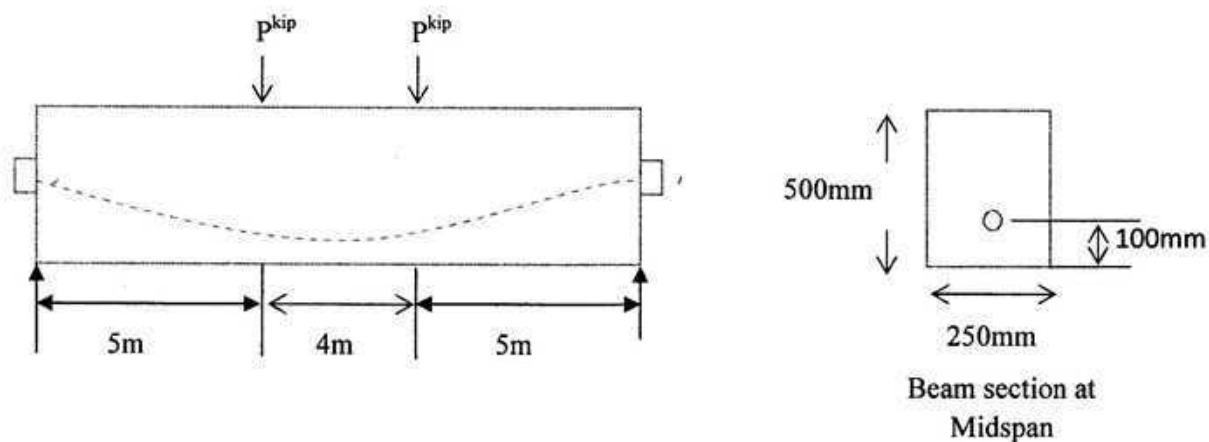

Fig: 1

2. (a). A pretensioned concrete member (Fig: 2) has a simple span of 14m and it is prestressed with 780 mm² wires which are anchored to the bulkhead to with an initial prestress of 1100 MPa. If $E_{ci} = 33000$ MPa and $E_s = 200000$ MPa, Compute the stress at section 1-1 after elastic shortening of concrete. (15)

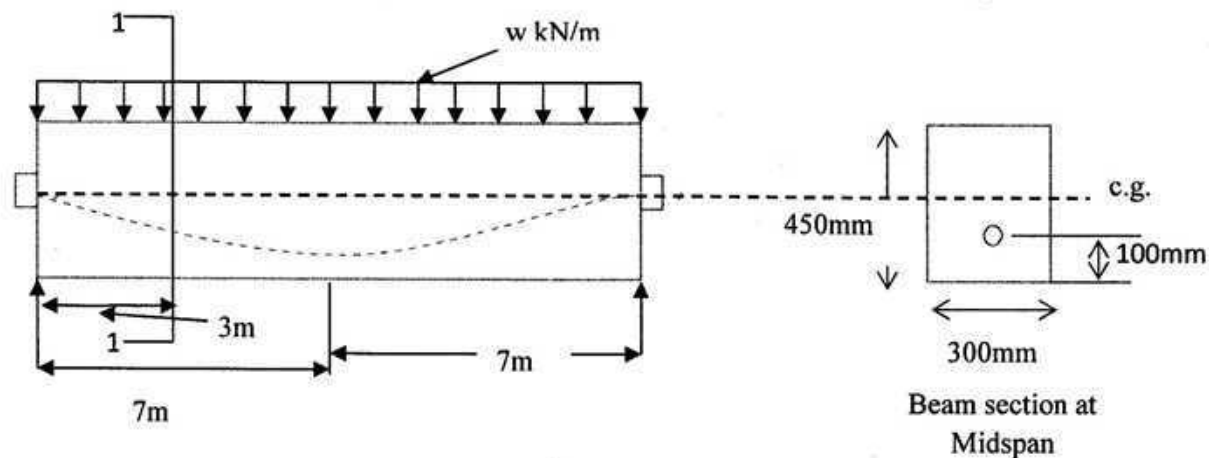
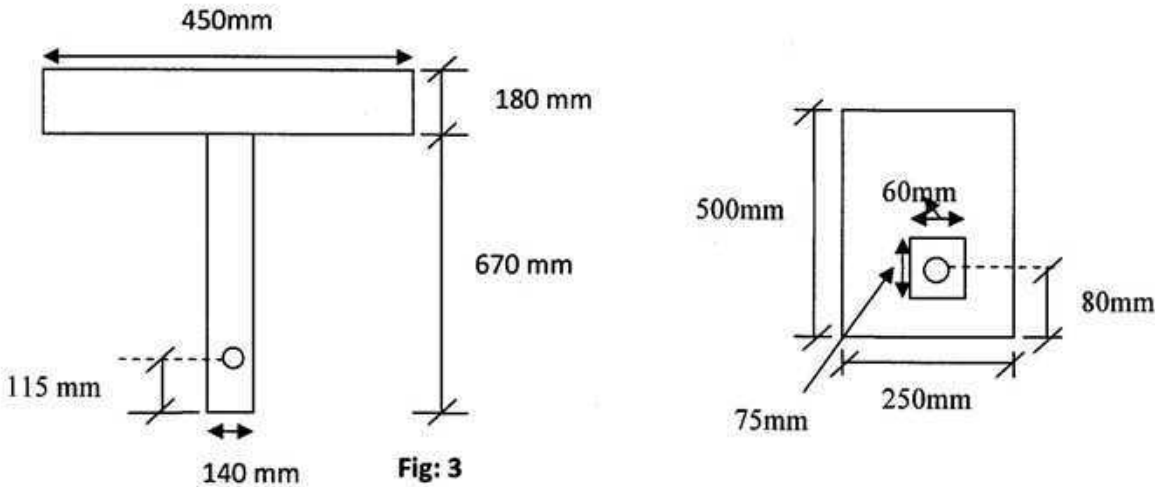

Fig: 2

(b) Write down the name of the losses of prestress concrete. (Names only) (5)

3. (a) A T-beam is prestressed with 1650 mm^2 steel with an effective stress 1100. The c.g.s of strands which supply the prestress is 115mm above the bottom of the beam as shown in Fig: 3. Find the ultimate moment capacity of the section for design. (Given: $f_{pu}=1800 \text{ MPa}$, $f'_c=48 \text{ MPa}$) (12)



(b). What are the differences between prestressed concrete and reinforced concrete? (8)

4. (a) What are the differences between partial prestressing and fully prestressing? (5)

(b) A post-tensioned beam has a midspan cross section with a duct of 60mm by 75mm to house the wires, as shown in Fig:4. It is prestressed with 625 mm^2 of steel to an initial stress of 1040 MPa. Immediately after transfer the stress is reduced by 5% owing to anchorage loss and elastic shortening of concrete. Using net section of concrete, compute the stresses in the concrete at transfer. (15)

Required Formulae

- ❖ $f_c = -(F/A) \pm (Fey/I) \pm (My/I)$
- ❖ $\Delta f_s = n [-(F/A) \pm (Fe^2/I) \pm (Me/I)]$
- ❖ $f_c = -(F/A_c) \pm (Fey/I)$
- ❖ $f_c = -(F/A_g) \pm (Fey/I)$
- ❖ $f_{ps} = f_{pu} \{1 - 0.5\rho_p (f_{pu}/f'_c)\}$
- ❖ $\rho_p = A_{ps}/bd$
- ❖ $a = (A_{ps} f_{ps} / 0.85 f'_c b)$
- ❖ $w_p = (\rho_p f_{ps} / f'_c) \leq 0.3$
- ❖ $M_u = \phi A_{ps} f_{ps} \{d - (a/2)\}$
- ❖ $A_{pf} = \{0.85 f'_c (b - b_w) h_f\} / f_{ps}$
- ❖ $A_w = A_{ps} - A_{pf}$
- ❖ $\rho_w = (A_w / b_w d)$
- ❖ $w_{pw} = (\rho_w f_{ps} / f'_c) \leq 0.3$
- ❖ $M_u = \phi [A_{pf} f_{ps} \{d - (h_f/2)\} + A_w f_{ps} \{d - (a/2)\}]$
- ❖ $\phi = 0.9$

The University of Asia Pacific
Department of Civil Engineering
Mid-term Examination Spring' 2014

Course No. & Title: CE 417 Structural Engineering VI (Design of Steel Structures)

Full Marks: 20 Time: 1 hour

The figures in the margin indicate full marks.

Notations convey their usual meanings. Assume reasonable values for any missing data.

There are FOUR questions. Answer any THREE questions.

- For the complete penetration groove welded joint, shown in Fig. 1, $L=10$ in. & $T=5/8$ in. Using AISC/LRFD method determine what live load can be transmitted through the joint, if the simultaneous dead load is 100 kip. All material is A36. Welds are deposited manually using E70XX electrode. AISC specified nominal strength is 0.6 times the nominal tensile strength of weld metal and $\phi=0.8$. 6 2/3

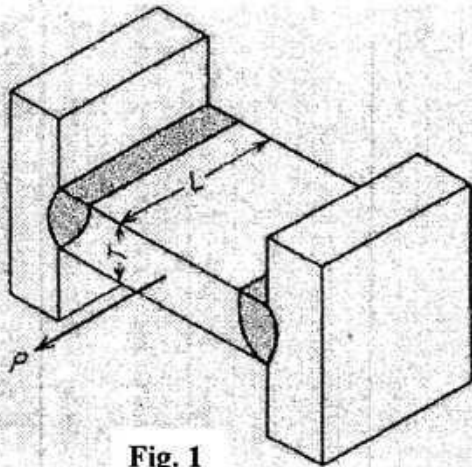

Fig. 1

- A 8x6x1-in. angle is connected by two rows of 7/8-in. bolts in the 8-in. leg and one row in the 6-in. leg (staggered as shown in Fig. 2) in standard holes. Determine the probable net areas for the angle and also calculate the design strength in tension based on section areas using AISC/LRFD method. Given: $A_g = 13$ in² for the angle; $U = 0.85$; Angle is of A36 steel. 6 2/3

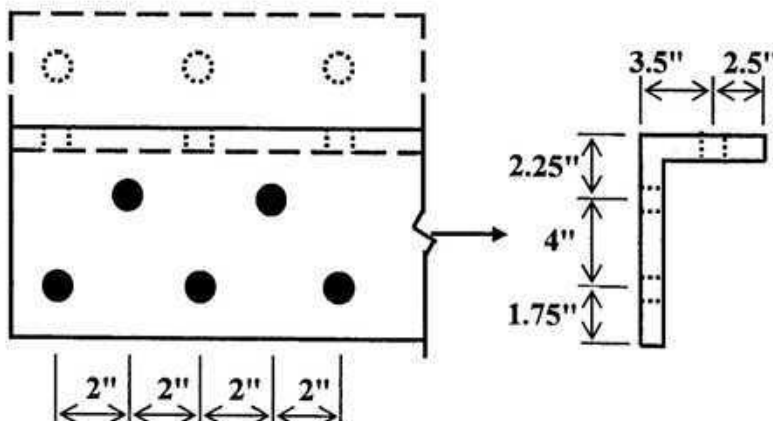

Fig. 2

3. A joint is designed with two lines of bolts to transmit a load through two L7x4x5/8 to a 3/4-in. gusset plate (Fig. 3). All material is A36 and the bolts are 3/8-in. A325 (Standard holes) in a bearing-type connection with threads excluded from shear planes. Using AISC/ASD method, determine the capacity of this joint by checking (i) shear in the bolts and (ii) bearing in the angles and gusset plate. The capacity of the tension member is not required to be checked. Given: Allowable stress in shear for bolts with no thread in shear planes = 30 ksi; Allowable stress in bearing = $1.2 F_u$.

6 3/8

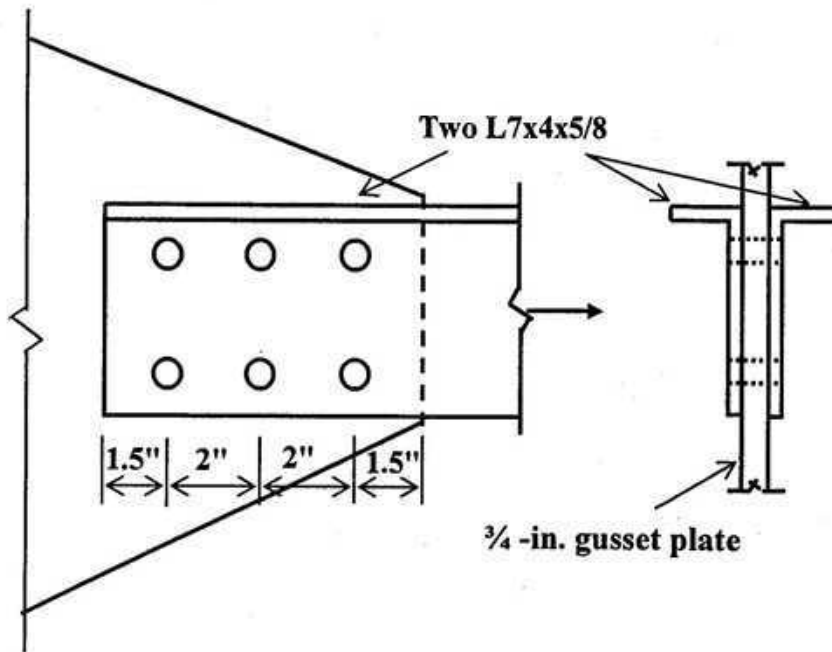

Fig. 3

4. For a bolted joint subjected to tension show that,

$$\frac{L_e}{D} = \frac{0.714 f_p}{F_u} + \frac{1}{2}$$

where the symbols have their usual meanings. Making necessary assumptions, reduce the aforementioned expression into the usual forms as used in AISC/ASD and AISC/LRFD specifications.

6 3/8

University of Asia Pacific
Department of Civil Engineering
Mid Semester Examination Spring 2014

Course No: CE 423
 Course Title: Structural Engineering IX
 (Earthquake Resistant Design and Retrofitting)

Time: 1 Hour
 Full Marks: 60

There are 3 questions. Answer all of them.

1. a) Define undamped, critically damped and overdamped systems. Derive equation of motion of a overdamped SDOF system with free vibration. (3+10)
- b) For the (22' × 22' × 22') overhead water tank shown below supported by a 24" × 24" square column, calculate the undamped natural frequency for (i) horizontal vibration, (ii) vertical vibration. Assume the total weight of the system to be concentrated in the tank [Given: Modulus of elasticity of concrete = 380×10^3 k/ft², Unit weight of water = 62.4 lb/ft³]. (7)

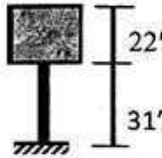

2. a) What is Seismic Base Isolation? Discuss the effects of Seismic Base Isolation on structure. (2+6)
 - b) Write down the specifications for seismic detailing of a flexural member of RC structure. (6)
 - c) Write short notes on (i) Lap-splice (ii) Development length. (3+3)
3. The exterior joint shown in the Figure below is a part of a reinforced concrete frame designed to resist earthquake loads. A 6 in slab, not shown, is reinforced with No. 5 bars spaced 10 in center-to-center at the same level as the flexural steel in the beams. The member section dimensions and reinforcement are as shown. The frame story height is 12 ft. Material strengths are $f'_c = 4000$ psi and $f_y = 60000$ psi. The maximum factored axial load on the upper column framing into the joint is 2100 kips, and the maximum factored axial load on the lower column is 2300 kips. Check if the joint satisfy weak beam strong column design as per ACI 318-08. (20)

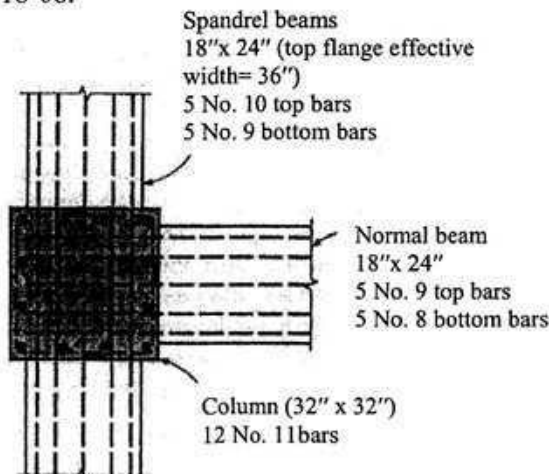

University of Asia Pacific
Department of Civil Engineering
Mid Semester Examination Spring 2014
Program: B.Sc. Engineering (Civil)

Course Title: Environmental Engineering III
 Time- 1 hour

Course Code: CE 431
 Full marks: 60

Answer all the questions below:

1. (a) What is the significance of source reduction ? (5)
- (b) What are the functional steps to be followed for an effective solid waste management system ? (5)
- (c) Differentiate between the hauled container system and stationary container system in solid waste management with necessary figures. (2.5+1.5)
- (d) What are the factors that affect the solid waste generation rate ? (3)
- (e) Write down the benefits of recycling and reuse in the environmental point of view. (7)
2. (a) Estimate the energy content for the organic portion of a solid waste sample with the composition given below: (10)

| Component | Wet mass (kg) | Composition (kg) | | | | | Ash |
|-----------------|---------------|------------------|------|------|------|------|------|
| | | C | H | O | N | S | |
| Food wastes | 45 | 13 | 0.5 | 2.5 | 0.5 | 0.03 | 1.47 |
| Paper | 22 | 5.5 | 1.3 | 6.4 | 0.71 | 0.09 | 1.0 |
| Cardboard | 8 | 3.1 | 0.31 | 3.2 | 0.06 | 0.03 | 0.8 |
| Plastics | 5 | 3.3 | 0.35 | 1.1 | — | — | 0.15 |
| Garden trimming | 15 | 1.7 | 0.65 | 1.85 | 0.25 | 0.01 | 0.54 |
| Wood | 5 | 2.1 | 0.21 | 1.35 | 0.2 | — | 0.14 |
| — | 100 | 30.7 | 3.33 | 16.4 | 1.73 | 0.16 | 4.1 |

- (b) The United States discards roughly 167 million tons of MSW. The High Heating Value of those discards is about 6,000 Btu/lb. A mass-burn waste-to-energy facility (6)

can convert those wastes to electricity with a heat rate of 17,000 Btu of thermal input per KWh of electrical output (roughly 20% efficiency). Estimate the electrical energy that could be produced per year if all our discards were used in this type of WTE system. Compare it with the total that is now generated which is about $4,000 \times 10^9$ KWh/yr.

- (c) Do an economic analysis of refuse collection and also give an economic decision about what size truck makes sense for the following job. (20)

Solid wastes from Mirpur area to be collected using a stationary container collection system having 5 cubic meter containers. Suppose the annualized cost of purchasing, fueling and maintaining a compactor truck is given by the following expression:

$$\text{Annualized cost} (\$/\text{yr}) = \alpha + \beta V$$

Where, α and β are empirically determined which values are 25000 and 4000 respectively. V is the volume of truck in cubic yards.

The following conditions may be need for the analysis:

- Trucks require two person crews, with labor charged at 24\$ per hour (including benefits)
- The truck collects waste from 340 households each day.
- Each household generates 60lb of wastes per week.
- The trucks and crew work 5 days per week and alley pick up is provided once a week for each house.
- Container utilization factor = 0.70
- Average number of containers at each location = 1
- Collection - vehicle compaction ratio = 2.5
- Container unloading time = 0.15 h/ container
- Average drive time between container location = 0.15 h
- One way haul distance = 35 km
- Speed limit = 72 km/hr
- Time from garage to first container location = 0.25 h
- Time from garage to last container location = 0.35 h
- Number of trips to disposal site per day = 2
- Length of working day = 8h

$$(0.03704 \text{ cu yd} = 0.02832 \text{ m}^3)$$

University of Asia Pacific
Department of Civil Engineering
Mid Semester Examination Spring 2014
Program: B.Sc. Engineering (Civil)

Course Title: Environmental Engineering IV

Course Code: CE 433

Time- 1 hour

Full marks: 60

Answer all of the questions below

Assume reasonable value for any missing data (if applicable)

1. (a) Briefly explain sub-adiabatic and super-adiabatic atmosphere with relevant figure. (8)
(b) Why pollution exposure at home and workplace may often become greater than outdoors. (2)
(c) On June 20, 2014, the following air quality data was recorded at Shangshad Bhaban CAMS in Dhaka. (10)
PM_{2.5} = 150 µg/m³ (24 hr)
PM₁₀ = 250 µg/m³ (24 hr)
CO = 35 ppm (8 hr)
Identify the critical pollutant based on AQI. Also mention the respective sensitive groups.

2. (a) Classify air pollutants according to origin and chemical composition along with relevant examples. (4)
(b) Briefly describe the most ideal and quite bad conditions for dispersion of emission. (6)
(c) A coal fired power plant has a 200 m stack with inside radius of 4 m. The exit velocity of the stack gases is estimated at 10 m/s, at a temperature of 150°C. Ambient temperature is 30°C and wind speed at stack height is estimated to be 5 m/s. Estimate the effective height of the stack if – (10)
(i) the atmosphere is slightly stable with temperature increasing at the rate of 2°C/km
(ii) the atmosphere is slightly unstable.

3. (a) Explain the particle deposition mechanisms of impaction and diffusion with relevant figures. (6)
(b) Write down the assumptions for point source Gaussian Plume Model. (4)
(c) Cars travelling at 60 mph speed at 50 m apart are emitting 3 g/mile of CO. The wind speed is 5 m/s and perpendicular to the road. Estimate ground level concentration of CO at a distance of 150 m downwind. Consider atmosphere to be slightly unstable. (10)

University of Asia Pacific
Department of Civil Engineering
Midterm Examination Spring 2014
Program: B.Sc. Engineering (Civil)

Course code: CE 439

Course title: Environmental Engineering VII (Environmental Impact Assessment)

Time: 60 Minutes

Full marks: 20

Answer ALL questions

1. Define the following: (6)
 - Impact
 - Environmental Impact Assessment (EIA)
 - Screening
 - Baseline Study
 - Scoping
 - Impact analysis
2. Write four possible outcomes of screening process in EIA (1)
3. Draw the flow diagram of EIA process and parallel studies (3)
4. According to Article 7 of the Bangladesh Environmental Conservation Rules (1997), write the procedures to obtain environmental clearance certificate for a red category factory? (2.5)
5. Explain different levels and forms of public involvement (2)
6. Write the benefits of public participation during EIA process for the following stakeholder groups: (3)
 - The proponent/supporter
 - The decision-maker
 - Affected communities(Write four benefits for each stakeholder group)
7. Write six guiding principles of scoping in EIA? (1.5)
8. What are the common formal methods used for impact identification in an EIA process? (1)