

3-11

University of Asia Pacific
Department of Civil Engineering
Mid Semester Examination, Spring 2025
Program: B.Sc. in Civil Engineering
3rd Year 1st Semester

Course Title: Business Management
Time: 1 hours

Credit Hour: 3.00

Course Code: IMG 303
Full Marks: 20

ANSWER ANY TWO FROM THE BELOW THREE QUESTIONS

QUESTION 1 [5+5]

- a. Briefly describe the three types of management style and identify the best and worst one according to you.
- b. Discuss about the basic functions of management with relevant examples.

QUESTION 2 [5+5]

- a. "Entrepreneurs are managers but managers are not always entrepreneurs"- do you agree with this statement? Justify your answer on the basis of Mintzberg's decisional roles.
- b. Describe the concept of scientific management.

QUESTION 3 [5+5]

Imagine that you're the regional manager of a successful electronics retail chain. Your latest idea is to introduce a **new line of smart home security devices**. You've been passionate about smart tech, and your early research — mostly articles and vendors that support the trend — suggests the market is growing fast. You've pitched the idea to your leadership team, and they agree enthusiastically. No one raises objections, even though you didn't do a full market study for your region. After launch, early sales are slow, but you are confident and reassure yourself it just needs time. You also recently increased the price of one of the models from **\$320 to \$400**. You continue pushing the strategy despite concerns from some store managers about low sales and competitors offering better features at lower prices. You remain committed, thinking that since you've already spent so much on this, it would be a waste to scale back now.

- a. What is the percentage increase in price, and does it justify keeping the new price?
- b. Identify the decision-making errors that have occurred in this scenario and justify your answer.

QUESTION 3 [10 MARKS]

[10]

Analyze the plate girder ABCDEFG shown below in **Figure 3**, and draw the influence lines for Reaction at A (R_A) and Shear in panel AC (V_{AC}), if unit load passes over the stringers. [3 is an Internal Hinge]

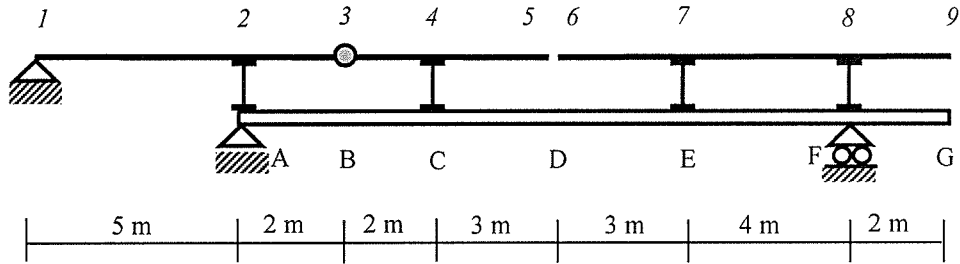

Figure 3

QUESTION 4 [8 MARKS]

[8]

Analyze the frame shown in **Figure 4** and draw the influence lines for Vertical Reaction at b (Y_b), Shear force at e (V_e), and Bending moment at e (M_e) if the unit load moves over beam cg. [d is an Internal Hinge]

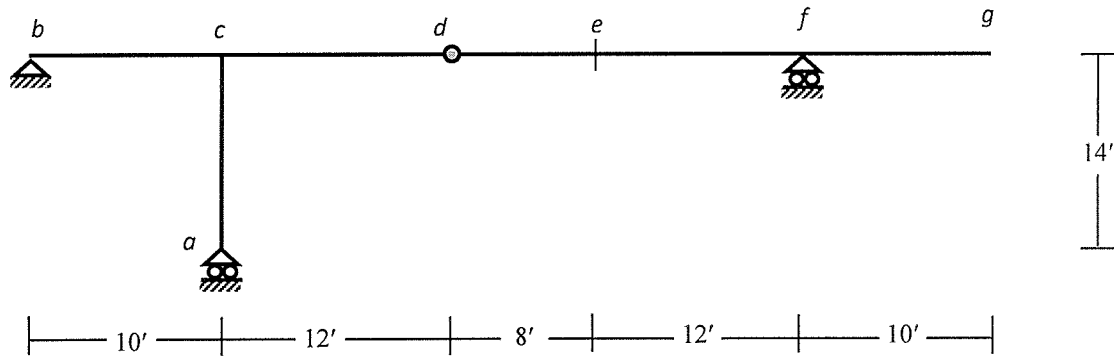

Figure 4

University of Asia Pacific
Department of Civil Engineering
Mid Semester Examination, Spring 2025
Program: B.Sc. in Civil Engineering
3rd Year 1st Semester

Course Title: Design of Concrete Structures I
 Time: 1 hour

Credit Hour: 3.00

Course Code: CE 315
 Full Marks: 60

Answer all the questions

QUESTION 1 [20 MARKS]

- a. Explain the general sequences of reinforced concrete design. [5]
- b. Explain with diagrams the three types of flexural failure with stress and strain limits. [5]
- c. Distinguish between WSD and USD design methods. [5]
- d. Explain the sources of uncertainty in reinforced concrete design. [5]

QUESTION 2 [20 MARKS]

Figure 1 shows a building plan with beam layout. **Design** the concrete cross section and the steel area required for a rectangular beam (B2-C2) as shown in the **Figure 1**, that is to carry a computed dead load of 1.5 kips/ft and a service live load of 2.5 kips/ft. Material strengths are $f'_c = 4000$ psi and $f_y = 60,000$ psi. Assume that the beam is simply supported.

QUESTION 3 [20 MARKS]

A simply supported beam (A1-B1, in **Figure 1**). has cross section as shown in **Figure 2**. **Analyze** the section to determine the design moment capacity of the beam. For simplicity, assume $d = d_i$. Use $f'_c = 5000$ psi, and $f_y = 60000$ psi. Assume that the beam is simply supported.

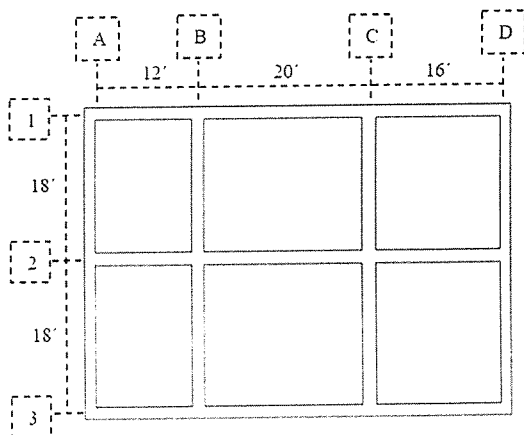

Figure 1: Beam layout

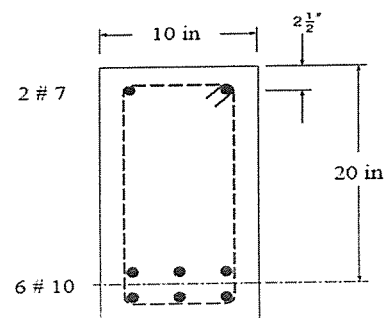

Figure 2: RC beam section

University of Asia Pacific
Department of Civil Engineering
Mid Semester Examination, Spring 2025
Program: B.Sc. in Civil Engineering
3rd Year 1st Semester

Course Title: Water Supply Engineering and Management
Time: 1 hours

Credit Hour: 3.00

Course Code: CE 331
Full Marks: 60

Answer all the Questions

QUESTION 1 [15 MARKS]

- (a) A water treatment plant is being designed to process 48,000 m³/d of water. Jar testing and pilot-plant analysis indicate that an alum dosage of 40 mg/L with flocculation at a Gt value of 4×10^4 produces optimal results. Determine: [2+4+4=10]
- i. The monthly alum requirement
 - ii. The flocculation basin dimensions. The flocculator should be a maximum of 12 m wide and 5 m deep
 - iii. The power requirement

Assume that the absolute viscosity of the water is 8.91×10^{-4} Pascals.second and velocity gradient for flocculation, $G = 40 \text{s}^{-1}$; $G = \left(\frac{P}{V\mu}\right)^{0.5}$

- (b) Explain the process of "adsorption and charge neutralization" in destabilizing colloidal particles with figures. [5]

QUESTION 2 [15 MARKS]

- (a) The Buriganga River near Dhaka is being considered as a raw water source for a new municipal water treatment plant. Laboratory analysis of the water shows: [5+5=10]
- High turbidity (200 NTU) and suspended solids
 - Hardness ≈ 250 mg/L as CaCO₃
 - Presence of iron and manganese above acceptable limits
 - Microbial contamination due to domestic wastewater discharge
- i. Propose a suitable water treatment scheme for this river source, showing the sequence of treatment units in a neat flow diagram
 - ii. Justify the inclusion of each unit operation based on the given water quality characteristics

- (b) Differentiate between the mechanism of RSF and SSF in removing particle. [5]

QUESTION 3 [15 MARKS]

- (a) A new surface water intake system is being planned for a highway-side township. The intake pipe is flexible (diameter = 2 ft) is buried within a trench of 4 ft below the highway. The top of the pipe is 6 ft below the surface of the fill. Due to traffic and soil fill, the ground is subjected to a uniform superimposed load of 85 lb/ft² over an area of 18 ft along the pipe length. [5+5=10]

At the same time, the intake station has been designed to draw water from the adjacent river. The entrance of the pipe is located 5 ft below the water surface and 12 ft above the river bed. Field measurements show an intake velocity of 5 fps.

- i. Calculate the total load on the pipe.
- ii. Comment on whether the intake station design is appropriate considering general intake design principles

Assume, Impact factor=1.5; Load calculation coefficient=1.18 (Trench)

Unit weight of fill=100 lb/cu. ft; Load calculation coefficient=0.20 (Superimposed)

- (b) Discuss the elements of water supply system with a neat diagram. [5]

QUESTION 4 [15 MARKS]

- (a) A well of 12-inch diameter has a depth of 100 ft below the level of water table and the depth of water when is being pumped is 80 ft. As indicated by the test on a sample, the coefficient of permeability is 1240 gpd/ft². The radius of drawdown is assumed to be 1000 ft. What is the rate of discharge of the well in gpm? [10]

- (b) Briefly discuss "Aquifer" and "Aquiclude". [5]

Necessary Formula:

1. $Q = \frac{\pi K(D^2 - d^2)}{\ln(R/r)}$
2. $V = 1.318 C R^{0.63} h_1^{0.54}$
3. $Q = VA$
4. $w = C\gamma BD$
5. $w = C_1 PID$
6. $w = Cp\gamma D^2$

University of Asia Pacific
Department of Civil Engineering
Mid Semester Examination, Spring 2025
Program: B.Sc. in Civil Engineering
3rd Year 1st Semester

Course Title: Geotechnical Engineering I
Time: 1 hour

Credit Hour: 3.00

Course Code: CE 341
Full Marks: 50

[There are **Four** questions here. **Answer all** the questions. Assume reasonable values of any data, if missing. Digits in the right margin inside the third parenthesis indicate marks.]

PART-A [25 MARKS]

QUESTION 1 [10 MARKS]

- (a) Define the following soil deposits: [4]
(i) Black Cotton (ii) Verved clay (iii) Erratics (iv) Loess
- (b) Classify different types of soils based on particle size according to American Association of State Highway and Transportation Officials (AASHTO). [3]
- (c) Define various types of secondary structures of soil. [3]

QUESTION 2 [15 MARKS]

- (a) A cone penetration test was carried out on a silty clay sample and the following data were obtained:

Trial No.	1	2	3	4	5
Cone Penetration (mm)	16	18	22	26	30
Water Content (%)	43	50	64	77	91

- Plot water content (%) versus cone penetration (mm) in a plain graph paper and hence estimate the liquid limit of the sample. [5]
- (b) The values of liquid limit and flow index of a silty clay sample, as estimated from the flow curve, have been found to be 56% and 20%, respectively. The natural water content and plastic limit of the sample were found to be 36% and 24%, respectively. From grain size analysis, clay fraction (smaller than 0.002 mm) of the sample was found to be 40%. Calculate liquidity index, consistency index, toughness index and activity of the sample. [4]
- (c) Define shrinkage limit.

The following data were obtained in a shrinkage limit test performed on a silty clay sample:

Weight of shrinkage dish = 10.8 gm

Volume of shrinkage dish = 16.3 cm³

Weight of shrinkage dish + saturated soil = 39.7 gm

Weight of shrinkage dish + oven-dry soil pat = 30.6 gm
 Weight of mercury displaced by oven-dry soil pat = 136.3 gm
 Unit weight of water and mercury are 0.9963 gm/cm³ and 13.6 gm/cm³, respectively.
 Calculate the values of shrinkage limit, shrinkage ratio and specific gravity of soil solids (Gs) of the sample. [6]

PART-B [25 MARKS]

QUESTION 3 [15 MARKS]

- (a) By drawing a qualitative graph show the effect of higher compactive energy on compaction. [2]
 (b) During construction of a highway, Modified Proctor test was performed in the laboratory on a silty sand sample and following results were obtained: [13]

Moisture content (%)	Dry unit weight (kN/m ³)
9.5	16.20
11	19.0
10	17.50
12.5	19.10
14	18.50

The following are the results of a field density test performed on the same soil following sand cone method.
 Calibrated dry density of Ottawa sand = 1595 kg/m³
 Calibrated mass of Ottawa sand to fill the cone = 0.433 kg
 Mass of jar + cone + sand (before use) = 9.31 kg
 Mass of jar + cone + sand (after use) = 6.13 kg
 Mass of wet soil from hole = 3.26 kg
 Moisture content of wet soil = 4.19 %

- a) Plot dry unit weight/density vs. moisture content in a plain graph paper and hence find the maximum dry density in laboratory and optimum moisture content.
 b) If the specification of this highway project demands 95% relative compaction as minimum which must be achieved, then check whether the field compaction meets the demand or not.

QUESTION 4 [10 MARKS]

From a construction site, a soil sample of 1m³ is collected as wet condition having an air content of 21%. After oven drying it's weight is found as 17.8 kN. If the specific gravity of the soil solid is 2.72, then find the following [10]

- Field moisture content.
- Porosity.
- Moist unit weight.
- Saturated unit weight.
- Submerged unit weight.

University of Asia Pacific
Department of Civil Engineering
Mid Semester Examination, Spring 2025
Program: B.Sc. in Civil Engineering
3rd year 1st Semester

Course Title: Open Channel Flow
Time: 1 hour

Credit Hour: 3

Course Code: CE 361
Full Marks: 40

Answer all the questions

QUESTION 1 [10 MARKS]

- a. "Uniform flow can be steady only". Justify the statement. [5]
b. Characterize open channel flow based on the effect of viscosity and gravity. [5]

QUESTION 2 [10 MARKS]

- a. Derive the momentum equation for an open channel flow. [5]
b. Derive the expression for critical depth in a rectangular channel [5]

QUESTION 3 [8 MARKS]

A broad-crested weir is built in a rectangular channel of width 1 m. The height of the weir crest above the channel bed is 0.60 m and the head over the weir, immediately upstream, is 0.40 m. Calculate the discharge. [8]

QUESTION 4 [12 MARKS]

In a wide channel the velocity varies along a vertical as $u = 1 + 2 \left(\frac{z}{h}\right)^{0.5}$, where h is the total depth and u is the velocity at a distance z from the channel bottom. The river is 5 m deep. Compute the mean velocity, discharge per unit width, and velocity distribution coefficients. [12]

